

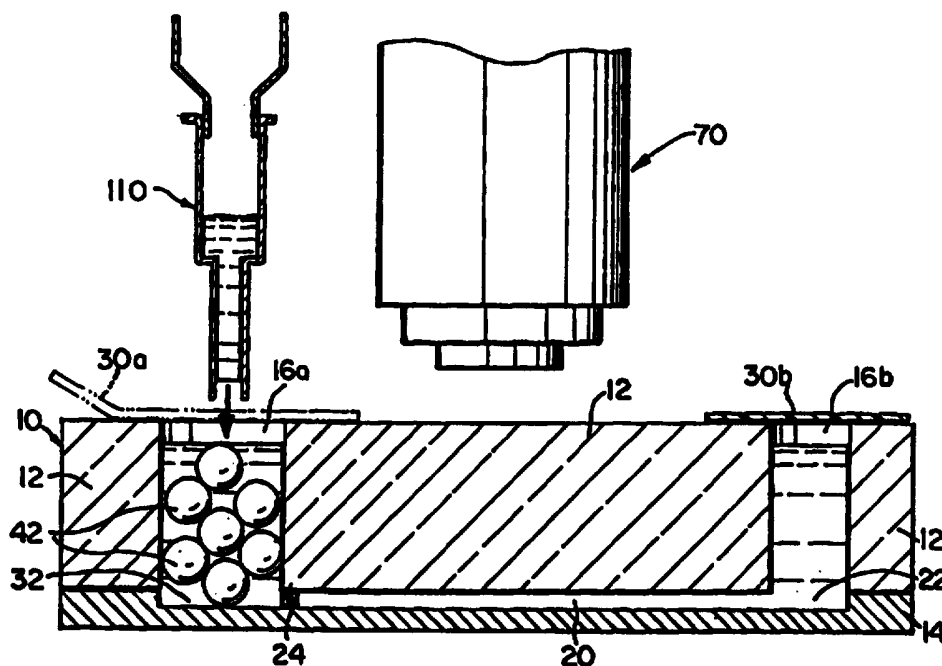

INTERNATIONAL APPLICATION PUBLISHED UNDER THE PATENT COOPERATION TREATY (PCT)

<p>(51) International Patent Classification ⁶ : B01L 3/00, A61D 19/00, C12M 3/04, A61K 35/52</p>	<p>A1</p>	<p>(11) International Publication Number: WO 96/14933 (43) International Publication Date: 23 May 1996 (23.05.96)</p>
<p>(21) International Application Number: PCT/US95/14824 (22) International Filing Date: 13 November 1995 (13.11.95) (30) Priority Data: 08/338,369 14 November 1994 (14.11.94) US 08/338,380 14 November 1994 (14.11.94) US 08/338,728 14 November 1994 (14.11.94) US (71) Applicant: TRUSTEES OF THE UNIVERSITY OF PENNSYLVANIA [US/US]; Suite 300, 3700 Market Street, Philadelphia, PA 19104 (US). (72) Inventors: KRICKA, Larry, J.; 886 Nathan Hale Road, Berwyn, PA 19312 (US). WILDING, Peter; 208 Darby Road, Paoli, PA 19301 (US). (74) Agents: HAGAN, Patrick, J. et al.; Dann, Dorfman, Herrell and Skillman, Suite 720, 1601 Market Street, Philadelphia, PA 19103-2307 (US).</p>		<p>(81) Designated States: AU, CA, CN, JP, MX, RU, European patent (AT, BE, CH, DE, DK, ES, FR, GB, GR, IE, IT, LU, MC, NL, PT, SE). Published <i>With international search report. Before the expiration of the time limit for amending the claims and to be republished in the event of the receipt of amendments.</i></p>

(54) Title: MESOSCALE DEVICES FOR ANALYSIS OF MOTILE CELLS



(57) Abstract

Devices and methods are provided to facilitate the rapid, accurate analysis of a sample having cells characterized by their motility. The devices comprise a solid substrate microfabricated to define a flow system including one or more ports or chambers. In one embodiment, the devices are provided for conducting replicate motile cell assays, or for conducting a series of different assays using a single test sample. In another embodiment, preparative devices are provided for separating and collecting selected motile cell types of interest. In another embodiment, a device designed for performing an *in vitro* fertilization is provided in a portable incubator, which maintains the *in vitro* fertilization under optimum conditions.

FOR THE PURPOSES OF INFORMATION ONLY

Codes used to identify States party to the PCT on the front pages of pamphlets publishing international applications under the PCT.

AT	Austria	GB	United Kingdom	MR	Mauritania
AU	Australia	GE	Georgia	MW	Malawi
BB	Barbados	GN	Guinea	NE	Niger
BE	Belgium	GR	Greece	NL	Netherlands
BF	Burkina Faso	HU	Hungary	NO	Norway
BG	Bulgaria	IE	Ireland	NZ	New Zealand
BJ	Benin	IT	Italy	PL	Poland
BR	Brazil	JP	Japan	PT	Portugal
BY	Belarus	KE	Kenya	RO	Romania
CA	Canada	KG	Kyrgystan	RU	Russian Federation
CF	Central African Republic	KP	Democratic People's Republic of Korea	SD	Sudan
CG	Congo			SE	Sweden
CH	Switzerland	KR	Republic of Korea	SI	Slovenia
CI	Côte d'Ivoire	KZ	Kazakhstan	SK	Slovakia
CM	Cameroon	LI	Liechtenstein	SN	Senegal
CN	China	LK	Sri Lanka	TD	Chad
CS	Czechoslovakia	LU	Luxembourg	TG	Togo
CZ	Czech Republic	LV	Latvia	TJ	Tajikistan
DE	Germany	MC	Monaco	TT	Trinidad and Tobago
DK	Denmark	MD	Republic of Moldova	UA	Ukraine
ES	Spain	MG	Madagascar	US	United States of America
FI	Finland	ML	Mali	UZ	Uzbekistan
FR	France	MN	Mongolia	VN	Viet Nam
GA	Gabon				

MESOSCALE DEVICES FOR ANALYSIS OF MOTILE CELLSReference to Related Applications

This application is a continuation-in-part of co-pending U.S. Application Serial No. 08/184,577, which
5 is a continuation of U.S. Application Serial No. 07/877,661, issued as U.S. Patent No. 5,296,375 on March 22, 1994, the disclosure of which is incorporated herein by reference. This application is being filed contemporaneously with commonly-owned U.S. Serial No.
10 [Attorney Docket No. G-1158], which is a continuation-in-part of U.S. Ser. No. 07/877,662, filed May 1, 1992, the disclosures of which are incorporated herein by reference. This application is also being filed contemporaneously with commonly-owned U.S. Serial No.
15 [Attorney Docket No. H-1203/122], which is a continuation-in-part of U.S. Serial Nos. 07/877,702 (filed May 1, 1992), 08/196,021 (filed Feb. 14, 1994) and 08/250/100 (filed May 26, 1994). All of the above-listed disclosures are incorporated herein by reference.

20

Background of the Invention

This invention relates generally to methods and apparatus for conducting analyses. More particularly,
25 the invention relates to the design and construction of small, typically single-use, modules capable of rapidly analyzing microvolumes of a fluid sample, with particular emphasis on analysis of motile cells.

30 In recent decades the art has developed a very large number of protocols, test kits and cartridges for conducting analyses on biological samples for various diagnostic and monitoring purposes. Immunoassays,

immunometric assays, agglutination assays, and analyses based on polymerase chain reaction, various ligand-receptor interactions, and differential migration of species in a complex sample all have been used to
5 determine the presence or concentration of various biological compounds or contaminants, or the presence of particular cell types.

Recently, small, disposable devices have been
10 developed for handling biological samples and for conducting certain clinical tests. Shoji et al. reported the use of a miniature blood gas analyzer fabricated on a silicon wafer. Shoji et al., Sensors and Actuators,
15 15:101-107 (1988). Sato et al. reported a cell fusion technique using micromechanical silicon devices. Sato et al., Sensors and Actuators, A21-A23:948-953 (1990). A microprocessor-controlled laser photometer has been manufactured for detecting blood clotting (Ciba Corning
20 Diagnostics Corp. USA).

Micromachining technology originated in the microelectronics industry. Angell et al., Scientific American, 248:44-55 (1983). Micromachining technology has enabled the manufacture of microengineered devices
25 having structural elements with minimal dimensions ranging from tens of microns (the dimensions of biological cells) to nanometers (the dimensions of some biological macromolecules). Most experiments involving structures of this size have related to micromechanics,
30 i.e., mechanical motion and flow properties. The potential capability of such structures has not been exploited fully in the life sciences.

Brunette (Exper. Cell Res., 167:203-217 (1986)
35 and 164:11-26 (1986)) studied the behavior of fibroblasts and epithelial cells in grooves in silicon, titanium-coated polymers and the like. McCartney et al. (Cancer

Res., 41:3046-3051 (1981)) examined the behavior of tumor cells in grooved plastic substrates. LaCelle (Blood Cells, 12:179-189 (1986)) studied leukocyte and erythrocyte flow in microcapillaries to gain insight into microcirculation. Hung and Weissman reported on fluid dynamics in micromachined channels, but did not produce data associated with an analytic device. Hung et al., Med. and Biol. Engineering, 9:237-245 (1971); and Weissman et al., Am. Inst. Chem. Eng. J., 17:25-30 (1971). Columbus et al. utilized a sandwich composed of two orthogonally orientated v-grooved embossed sheets in the control of capillary flow of biological fluids to discrete ion-selective electrodes in an experimental multi-channel test device. Columbus et al., Clin. Chem., 33:1531-1537 (1987). Masuda et al. and Washizu et al. have reported the use of a fluid flow chamber for the manipulation of cells (e.g. cell fusion). Masuda et al., Proceedings IEEE/IAS Meeting, pp. 1549-1553 (1987); and Washizu et al., Proceedings IEEE/IAS Meeting pp. 1735-1740 (1988). The potential of using very small scale devices for the analyses of biological fluids, cells and microorganisms has heretofore remained largely unexplored. Current larger-scale analytical techniques utilized for the detection or analysis of microorganisms and cells are rarely automated, generally not portable, and can often be slow and cumbersome. As a result, a need exists for convenient and rapid systems for clinical, laboratory, and field assays.

There is particularly a growing need for standardized procedures for the analysis of semen, capable of providing reliable and rapid results, which may be used in the assessment of male infertility, and also for a range of other applications including *in vitro* fertilization (IVF), artificial insemination by donor semen (AID) and forensic medicine (The World Health Organization, WHO Laboratory Manual for the Examination

of Human Semen and Semen-Cervical Mucus Interaction, Cambridge University Press, Cambridge, U.K., 1987). The evaluation of male infertility through the analysis of semen involves a range of tests including the assessment
5 of sperm count, motility, morphology, sperm antibodies, sperm cervical mucus interaction and sperm biochemistry. Wang et al., American Association for Clinical Chemistry, Endo. 10:9-15 (1992). There is a need for systems
10 capable of conducting a range of rapid and reliable analyses of a sperm sample.

In U.S. Patent No. 5,296,375, which is commonly owned with the present application, there are described various devices for analysis and manipulation of motile
15 cells, such as sperm. These devices comprise a solid substrate microfabricated to define a sample inlet port and a mesoscale channel and chamber system.

Some of the features and benefits of devices
20 constructed in accordance with the teachings disclosed U.S. Patent No. 5,296,375 are summarized in Table 1. Those devices can be used to implement a range of rapid clinical tests for the analysis of a biological sample. With respect to sperm analysis, the devices can be used
25 to implement a range of rapid clinical tests for the analysis of a sperm sample. The devices may be utilized, e.g., for the detection of the motility or morphology of a sperm sample or to test the presence of sperm antibodies, or to test the interaction of sperm with
30 cervical mucus, or other assays used in infertility testing. In addition, the devices may be utilized to test the interaction of a sperm sample with other reagents such as spermicides. The invention described in U.S. Patent No. 5,296,375 provides methods and devices
35 for use in a wide range of possible assays. Assays may be completed rapidly, and at the conclusion of the assay the chip can be discarded, which advantageously prevents

contamination between samples, entombs potentially biologically hazardous material, and provides an inexpensive, microsample analysis.

5

TABLE 1

	<u>Feature</u>	<u>Benefit</u>
10	Flexibility	No limits to the number of device designs or applications available.
15	Reproducible	Allows reliable, standardized, production of devices.
20	Low Cost Production	Allows competitive pricing with existing systems. Disposable nature for single-use processes.
25	Small Size	No bulky instrumentation required. Lends itself to portable units and systems designed for use in non-conventional lab environments. Minimal storage and shipping costs.
30	Microscale	Minimal sample and reagent volumes required. Reduces reagent costs, especially for more expensive, specialized test procedures. Allows simplified instrumentation schemes.
35		

5	Sterility	Devices can be sterilized for use in microbiological assays and other procedures requiring clean environments.
	Sealed System	Minimizes biohazards. Ensures process integrity.
10	Multiple Circuit Capabilities	Can perform multiple processes or analyses on a single device. Allows panel assays.
15	Multiple Detector Capabilities	Expands capabilities for assay and process monitoring to virtually any system. Allows broad range of applications.
20	Reusable Devices	Reduces per process cost to the user for certain applications.

Ongoing research involving the above-mentioned devices has led to the discovery of a number of modifications and additions to the devices that can improve their effectiveness for analyses of sperm and other motile cells. Devices and methods incorporating these improvements are set forth in detail in the description, drawings, and claims which follow.

30 Summary of the Invention

The invention provides methods and apparatus for analyzing cell motility and for measuring other properties of cells of interest. The devices of the invention may be used in a range of applications, including sperm motility and morphology testing and *in vitro* fertilization, as well as motility and morphology

testing of other cell types including various microorganisms and chemotactic cells.

5 According to one aspect of the invention, a device is provided for analyzing a sample having cell characterized by their motility. The device comprises a solid substrate having a flow system which includes at least one elongate flow channel of mesoscale cross-sectional dimension, and a receiving well communicating
10 with the channel and defining a starting point in the channel. The device further comprises a cover for the substrate, which closes the channel and has a port in registry with the receiving well, for introducing the sample into the receiving well. Motile cells in the
15 sample travel from the receiving well to various progress points along the channel. The cover of the device also defines a second port to the channel at some point along the channel, preferably distal to the receiving well. In one embodiment, the second port comprises a hole in the
20 cover in registry with the channel at point therealong. In another embodiment, the channel extend to an edge of the substrate and the port is formed at that edge upon closing the channel with the cover.

25 In another embodiment, the above-described device further comprises a target chamber communicating with the channel and defining a terminating point in the channel. In this embodiment, the second port is preferably in registry with the target chamber.

30 The devices of the present invention comprise a number of features for regulating the flow of a sample fluid from the receiving well into the mesoscale flow channel. According to one aspect of the present
35 invention, the device described above is provided with a seal for the second port, for sealing the second port during introduction of the sample into the receiving

well. The seal may be permanent or removable. In accordance with the present invention, it has been discovered that this modification significantly reduces sudden bulk ingress of the sample fluid from the receiving well to the channel, thereby ensuring that cell movements observed in the flow channel are due to the inherent motility of the cells being assessed, and not to the flow properties of the sample fluid.

10 According to another aspect of the invention, devices are provided wherein the receiving well further includes a plurality of flow-regulating solids having a size and shape effective to permit passage of non-aggregated motile cells of interest from the receiving well into the channel and concomitantly to substantially restrain passage into the channel of other particulate matter in the sample, such as cellular aggregates, large particles, gelatinous material and the like. In one embodiment, the flow-regulating solids, such as glass or latex beads, are added to the receiving well. In another embodiment, the flow-regulating solids comprise an array of projections fabricated in the substrate at a position in the receiving well adjacent to the communicating terminus of the channel.

25 According to another aspect of the present invention, a device is provided wherein the receiving well further includes a cell director comprising flow-guiding ribs longitudinally aligned with the channel for directing motile cells in the sample from the receiving well into the channel.

The devices of the present invention also comprise several modification facilitating their utility as preparative devices, i.e. for separation and/or collection of motile cells of interest. According to one aspect of the present invention, devices such as those

described above are provided wherein the cover includes at least one additional port in registry with at least one progress point along the channel, thereby providing access to motile cells disposed in the channel at that
5 progress point. In one embodiment, the flow system of this device further comprises at least one sampling chamber disposed along the channel at the progress point, in fluid communication with the channel. In this
10 embodiment, the cover comprises at least one additional port in registry with the sampling chamber.

According to another aspect of the invention, a preparative device is provided in which the channel
15 comprises a tortuous region and selection region, the selection region being adapted for selective separation of a least one motile cell type from a mixed population of cell types. In one embodiment, the selection region
20 comprises a capture agent which selectively binds the cell type of interest, or alternatively to another cell type in the mixed population, with fluid flow in the channel thereafter separating the captured cell type from the unrestrained cell type. Optionally, two or more
25 target chambers may be provided for collecting two or more motile cell types of interest. In another embodiment, the selection region comprises an electric field which selectively influences motility of the cell type of interest, thereby effecting separation of that cell type from other cells in the mixed population.

30 According to yet another aspect of the present invention, an apparatus is provided for performing an *in vitro* fertilization. The apparatus includes a device of the invention, which comprises a solid substrate and at least one elongate flow channel of mesoscale cross-
35 sectional dimension, a receiving well communicating with the channel and defining a starting point in the channel, an egg nesting well communicating with the channel and

defining a terminating point in the channel, and a cover for the substrate which closes the channel and has a port for introducing a sperm sample in the receiving well, and another port in registry with the egg nesting well. The device is disposed in a portable, sealable, environmental control chamber, which includes a holding region for holding the device, and optionally a temperature regulating system and/or a humidity control system. The apparatus may also include a system for producing an atmosphere in the chamber conducive for the *in vitro* fertilization.

Various methods are provided for operating the devices of the invention described above. According to one aspect of the invention, a method is provided for analyzing a fluid sample having cells characterized by their motility. A device is provided which comprises a solid substrate having a flow system comprising at least one elongate channel of mesoscale cross-sectional dimension and a receiving well communicating with the channel and defining a starting point in the channel. The device includes a cover for the substrate which closes the channel and possesses a port in registry with the receiving well; the cover further defines a second port in registry with the channel at a point therealong. The flow system of the device is filled with a carrier fluid, and the test sample is introduced into the receiving well. The resident conditions of the combined carrier fluid and the test sample are controlled to assure motility of the cells in the carrier fluid. The cells are observed in the test sample as they travel from the receiving well to various progress points along the channel, which may be observably marked, and data are collected based on those observations. The analysis is completed using the data collected.

In one embodiment, the resident conditions of the combined carrier fluid and test sample are controlled by sealing the second port of the device prior to
5 introducing the test sample into the receiving well. The seal may be permanent or it may be removed after the assay is complete. In another embodiment, the resident
condition are controlled by providing in the receiving well a plurality of flow-regulating solids, having a size
10 and shape effective to permit passage of the motile cells from the receiving well into the channel and concomitantly to substantially restrain passage into the channel of selected particulate matter in the test
sample. In another embodiment, the resident conditions
15 are controlled by providing in the receiving well a cell director comprising flow-guiding ribs longitudinally aligned with the channel, which function to direct the motile cells from the receiving well into the channel.

20 According to another aspect of the present invention, a method is provided similar to that described above, which further includes generating replicate sets of data by conducting the above-described method in a device which further comprises a plurality identical flow
25 systems. By conducting the methods simultaneously in each of the plurality of flow systems, replicate sets of data for the analysis are generated.

30 According to another aspect of the present invention, the methods described above further include conducting a plurality of different analyses on a single sample. For this method, a device of the invention is provided which further comprises a multiplicity of non-
35 identical flow systems designed for the plurality of analyses, each flow system being filled with a carrier fluid which optionally contains reagents for each analysis. An aliquot of the sample is introduced into

each receiving well, and the cells in each flow system are observed. Data are collected based on those observations, and the analyses are made using the data.

5 According to yet another aspect of the present invention, a method is provided as described above which further includes selectively separating and optionally collecting a least one motile cell type from a sample comprising a mixed population of cell types. In this
10 method, a device is provided in which the flow channel comprises a selection region, adapted for selected separation of a cell type of interest and, optionally, for two or more cell types of interest. The sample is introduced into the receiving well, whereafter the mixed
15 population of cell types migrates through the selection region of the channel, resulting in selective separation of the motile cell type of interest from the mixed population of cell types. The motile cell type can then be collected.

20

 According to still another aspect of the present invention, a method is provided for performing *in vitro* fertilization. An *in vitro* fertilization device, as described above, is filled with appropriate *in vitro*
25 fertilization medium, one or more eggs in the egg nesting well and a sperm sample in the receiving well. The *in vitro* fertilization device is then placed in a portable, sealable, environmental control chamber for a time and under conditions effective to enable the sperm to reach
30 and fertilize the egg.

 The devices and methods of the invention may be used in a wide range of assays to rapidly generate an accurate assessment of cell motility, as well as other
35 features of motile cells of interest, from a single test sample. The numerous features and benefits of the device and methods of the present invention will become apparent

from the following description, examples and drawings.

Brief Description of the Drawings

5 Figure 1 is a diagrammatic view of device 10 according to the invention having a substrate 14 and cover 12 with a receiving well 32 for accepting a test sample introduced by a delivery apparatus 110, such as a pipette or syringe, via an inlet port 16a, the device
10 having a mesoscale flow channel in which the sample may be viewed by a an optical system 70, such as a microscope. Ports 16a and 16b over receiving well 32 and target chamber 22, respectively, are sealed by seals 30a and 30b respectively, the removable seal 30a for the
15 receiving well being shown in broken lines. Receiving well 32 and inlet port 16a are shown filled with flow-regulating particles 42, and a mesoscale filter 24 is disposed at the entrance of flow channel 20.

20 FIGURE 2A is a fragmentary face view of a substrate 14 of the type shown in Figure 1, in which the bottom surface of the receiving well 32 comprises a cell director having a parallel series of flow-guiding ribs 34 connected with flow channel 20.

25 FIGURE 2B is view similar to Figure 2A, showing an alternative form of substrate 14 in which receiving well 32 is provided with flow-guiding ribs 34 and is connected with two similar mesoscale flow channels 20.

30 FIGURE 3 is a face view of a substrate 14 of the type shown in Figure 1, in which the bottom surface of receiving well 32 comprises a flow-regulating structure having a series of protruding posts 44 disposed
35 adjacent to the entry of flow channel 20.

FIGURE 4 is a fragmentary face view of device 10 in which the substrate 14 is provided with a tortuous flow channel 20 extending from a receiving well 32 to a target chamber 22, a portion of the cover 12 being broken away for the purposes of illustration.

FIGURES 5, 6, and 7 are face views at a reduced scale, showing substrates 14 having multiple receiving wells 32, each connected to multiple flow channels 20, some of which terminate in separate or joined target chambers 22.

FIGURE 8 is view similar to Figure 5, showing a substrate 14 with a flow channel 20 leading from a receiving well 32 to a target chamber 22. Flow channel 20 is separated into two sections, a first section 20a being a tortuous channel and a second section being selection channel 20b for performing operations on the test sample in its flow from the receiving well 32 to the target chamber 22.

FIGURE 9A is an enlarged fragmentary view of substrate 14 similar to FIGURE 8, in which the selection section 20b of the flow channel is provided with a coating 28 for selecting a specified component of the sample.

FIGURE 9B is a view similar to Figure 9a, in which the selection section 20b of the flow channel is provided with a branch conduit 20c for diverting selected components of the sample.

FIGURE 10A is a view similar to Figure 4, illustrating another embodiment of device 10 in which the substrate 14 is provided with multiple flow channels 20 adapted to include sampling chambers 22b, the cover 12

for said substrate providing access ports 16 to different parts of the flow channels, sampling chambers 22b and target chamber 22a. Numerical markings (some of which are shown) are etched into substrate 14, adjacent to sampling chambers 22b.

FIGURE 10B is an enlarged fragmentary view of substrate 14 shown in to figure 10a, showing a flow channel 20 adapted to include sampling chamber 22b.

10

FIGURE 11 is face view of a device 10 with the cover 12 broken away to illustrate the substrate 14 with receiving wells 32, flow channels 20 and chambers 22 for performing different evaluations or analyses of a test sample.

15

FIGURE 12 is face view of the complete cover 12 which is broken away in Figure 11.

20

FIGURE 13 is a fragmentary face view of another embodiment of device 10 having flow channel 20 and multiple sampling chambers 22b disposed along the length of the flow channel 20.

25

FIGURE 14 is face view of device 10, having a configuration of receiving well 32, flow channel 20 and target chamber 22 that is different from the configurations shown in previous embodiments, being adapted for *in vitro* fertilization of an egg disposed in target chamber 22.

30

FIGURE 15 is a view of an *in vitro* fertilization device 10, which further comprises a fluid reservoir chamber 22b.

35

FIGURE 16 is partially diagrammatic view of a portable incubator 80 with portions broken away to show the components contained in the incubator.

5

Like reference characters in the respective drawn figures indicate corresponding parts. The drawn figures are not necessarily to scale.

10 Detailed Description

The present invention provides devices and methods for analysis of cell motility, which may be utilized in a wide range of clinical, laboratory and field applications. The devices and methods of the invention are particularly applicable for sperm handling, including sperm motility and morphology testing, sperm count, analysis of sperm viability, sperm penetration assays (e.g., through cervical mucus or hyaluronic acid), analysis of surface antigens, preparative separation of sperm, and *in vitro* fertilization. The devices and methods of the invention are also suitable for various analyses of a wide variety of motile cells, including, but not limited to, motile forms of bacteria, cyanobacteria and fungi, (e.g., slime molds), motile gametes such as sperm and zoospores, motile, unicellular plants and animals (e.g., protozoa, amoebae, *Euglena*) and chemotactic cells (i.e., cells that can be induced to motility by exposure to various chemical compounds). The devices and methods may be utilized in clinical tests (e.g., manipulation of sperm and *in vitro* fertilization, as described above), as well as in laboratory tests (e.g., screening of various cellular chemoattractants and chemorepellents) and in fields tests in the environmental and biological sciences (e.g., motility assessment of microorganisms in an ecosystem, under various environmental conditions). Thus, although sperm handling

and *in vitro* fertilization are often described and exemplified herein, those skilled in the art will appreciate that the devices and methods of the invention may be utilized in wide variety of motile cell assays, as
5 described above.

The devices of the invention (sometimes referred herein as "chips") comprise a solid substrate, fabricated to include a receiving well and a mesoscale
10 flow channel system extending from the receiving well. Depending on the type of assay for which the chip is designed, the flow channels may terminate in a target chamber. However, for many embodiments, this is not required. The flow channels may simply terminate within
15 the substrate, or alternatively may extend to an edge of the substrate.

In one embodiment, a sperm sample is introduced to the receiving well via an inlet port and the extent of
20 migration of the sperm through a flow system, which usually comprises a tortuous flow channel extending from the receiving well, can serve as an indication of, e.g., the motility or morphology of the sperm sample. In another embodiment, a target chamber may be included in
25 the device to serve as an egg nesting chamber, connected to the receiving well via an elongate channel of mesoscale cross-sectional dimension. A sperm sample is applied to the receiving well, and sperm in the sample then migrate competitively through the channel to the egg
30 nesting chamber, where fertilization of the egg occurs.

At least one of the chambers and/or flow channels of the device has a mesoscale dimension, i.e., at least one cross-sectional dimension on the order of
35 0.1 to 1000 μ m, more commonly less than 500 μ m. Flow channels leading to chambers have preferred widths and depths on the order of about 2.0 μ m to 300 μ m, more

preferably $3.0\mu\text{m}$ to $100\mu\text{m}$. For many applications, channels of $5\text{-}50\mu\text{m}$ widths are useful. Chamber in the substrate may have one or more larger dimensions, e.g., widths and/or lengths of a few millimeters. Preferred
5 depths of channels and chambers are on the order of 0.1 to $100\mu\text{m}$, typically $2\text{-}50\mu\text{m}$. In embodiments for analysis of human sperm, channels are typically about $100\text{-}150\mu\text{m}$ wide and about $40\mu\text{m}$ deep. The width is selected so as not to constrain tail movement of the sperm. Since sperm
10 size and tail length varies among species, widths should be selected depending on the species from which the sperm sample is taken. The depth of the chambers in the device optionally may be of mesoscale dimension (i.e. less than $1,000\mu\text{m}$, but the chambers generally have larger widths
15 and lengths, e.g., on the order of 1mm or larger. Typically, the entire device is of a length and/or width ranging from approximately 0.1 to a few (e.g., 5) centimeters. Devices of the invention also may include multiple ports and channels, in fluid communication with
20 one or more chambers. The port(s), channel(s) and/or chamber(s) may be fabricated in the substrate or, alternatively, in a cover disposed over the substrate, or both.

25 Devices comprising a solid substrate and optionally a cover disposed over the substrate, can be designed and fabricated with mesoscale flow channels and/or chambers from a wide range of materials. The devices optionally may be fabricated from a material
30 which can be sterilized easily. Silicon provides a useful material because of the well-developed technology permitting its precise and efficient fabrication. However, a wide range of other material may be used within the scope of the invention. Alternative preferred
35 materials for fabricating substrates of the invention include translucent or transparent materials such as quartz, glass, diamond, polycarbonate, polystyrene, or

other organic polymers such as polytetrafluoroethylenes. These materials are preferred in embodiments wherein a transparent device is desirable, e.g., for use with viewing devices wherein viewing is accomplished by passing electromagnetic energy through a sample. Other materials that may be utilized include, e.g., gallium, arsenide, indium phosphide, aluminum, polysilicon, silicon nitride, silicon dioxide, polyamide, various superalloys, zircaloy, steel, gold, silver, copper, tungsten, molybdenum, tantalum, KOVAR, ceramic, KEVLAR, KAPTON, MYLAR, brass, sapphire, or any of a range of plastics and organic polymeric materials available in the art.

The various ports, channels and chambers, as well as other functional elements of the device may be fabricated inexpensively in large quantities from, e.g., a silicon substrate by any of a variety of micromachining methods known to those skilled in the art. Micromachining methods available include film deposition processes such as chemical vapor deposition, laser-based fabrication or photolithographic techniques such as UV or X-ray processes, LIGA processes or plastic molding, or etching methods which may be performed by either chemical processes or plasma processes (see, e.g. Manz, et al., Trends in Analytical Chemistry 10: 144-149, 1991). The arrangement of channels, chambers, and ports facilitate the sequential, properly timed and volumetrically correct addition of samples and reagents within the devices.

Flow channels of varying widths and depths can be fabricated with mesoscale dimensions for use in analyzing sperm samples. The substrate containing a fabricated mesoscale flow channel may be covered and sealed, e.g., clamped or anodically bonded, with a thin glass cover. Other clear or opaque cover materials may be used, including various organic polymers such as

polycarbonate, polystyrene, polyethylene, and the like. Alternatively, two substrates can be sandwiched, or a substrate can be sandwiched between two transparent covers. This embodiment is particularly useful if the various channels and chambers in the substrate are fabricated to span the entire depth of the substrate. The covers then form a transparent top and bottom surface of the device, which is convenient for viewing the sample with a conventional microscope. Thus, transparent covers can be used to form windows that facilitate dynamic viewing of the channel contents, and allow optical probing of the mesoscale flow system either visually or by machine. Other fabrication approaches may be used.

The capacity of the devices of the invention is small, enabling assays to be performed on very small amounts of a liquid sample (e.g., less than $50\mu\text{l}$ and preferably less than $10\mu\text{l}$). The mesoscale devices may be fabricated for use with microliter volumes, or alternatively nanoliter volumes or less, which advantageously limits the amount of sample, buffer or other fluids required for an analysis. The devices may be used to implement a variety of automated, sensitive and rapid analyses, including various sperm characterization assays. At the conclusion of an assay, the devices may be cleaned and re-used, or discarded. The use of disposable devices eliminates contamination and reduces biohazard.

The devices of the invention containing a mesoscale channel system can be used in combination with an appliance for delivering and receiving fluids to and from the devices, which may incorporate a nesting site for holding the device, and for connecting ports on the device, with a flow line in the appliance. The appliance may also include a pump, which may be used to inject or withdraw sample fluids into or from the device.

Alternatively, the sample may be injected into the device, by e.g., syringe or pipette or may enter the flow system simply by capillary action. Devices such as valves and other mechanical sensors for detecting sample fluid in the devices can be fabricated directly on the substrate and can be mass-produced according to well established technologies. Angell et al., Scientific American, 248:44-55 (1983). Alternatively, sensors such as optical detectors and other detection means may be provided in the appliance utilized in combination with the device. In another embodiment, the substrate may be disposed, e.g., in an appliance, at an angle with respect to a horizontal plane, to provide an incline for the travel of a sperm sample, to further enhance the detection of motility.

The devices of the invention also may be utilized in combination with an appliance for viewing the contents of the devices. The viewing appliance may comprise a microscope for viewing the contents of the chambers and channels in the devices. The appliance may also include a camera, an optical system, and a tilt mechanism for holding the device, and allowing the placement and angle of the device to be adjusted manually.

The devices may be microfabricated with a mesoscale flow channel that includes a detection region for detecting a component of a sperm sample, such as sperm antibodies or hormones. The detection region may comprise a binding moiety, capable of binding to a predetermined component of the cell sample. The binding moiety, such as an antigen binding protein, may be immobilized on the surface of the flow channels, or on a solid phase reactant such as a bead. The detection chamber may be utilized in a range of binding assays, e.g., to assay the interaction of a sperm sample with

cervical mucus, to test the efficacy of spermicides, to assay for the presence of antibodies or contaminants in the sample, or to conduct sperm counts. The devices also may be fabricated with various thermal regulating systems for controlling temperature in one or more of the wells, channels and chambers.

The foregoing features of devices of the invention are described in greater detail in commonly owned U.S. Patent No. 5,296,375, incorporated herein by reference. The use of a binding moiety for assays in a mesoscale detection chamber, as well as techniques for providing the binding moiety in the detection chamber, are disclosed in commonly-owned co-pending Application Serial No. 07/877,702, filed May, 1992, the disclosure of which has been incorporated herein by reference. Thermal regulation in devices of the invention is described in greater detail in commonly-owned co-pending Application Serial No. 08/308,199, the disclosure of which has been incorporated herein by reference.

The devices of the invention may be used to perform a variety of cell motility assays and related manipulations. A typical device of the present invention is illustrated schematically in Figure 1. Device 10 includes a substrate 14 and a cover 12, fabricated with ports 16a and 16b, receiving well 32 and target chamber 22, connected by mesoscale flow channel 20. A mesoscale filter 24, such as those described in commonly-owned U.S. Patent No. 5,296,375, is optionally placed at the mouth of flow channel 20. The cover 12 is fabricated with ports 16a and 16b to fit directly over and register with the receiving well 32 and target chamber 22 respectively. Placement of cover 12 together with substrate 14 results in the formation of an enclosing wall of flow channel 20, leaving receiving well 32 and target chamber 22 open to the atmosphere via ports 16a and 16b. In an alternative

embodiment, the target chamber may be omitted, but should be replaced with a port, disposed anywhere over the flow system, to facilitate filling or evacuating the device.

5 In practice, after hydraulically filling all channels with an appropriate biological medium (e.g., a buffer or a specific cellular medium, such as cervical mucus as a liquid sperm medium) a sample comprising the motile cell of interest (e.g. a sperm sample) is applied
10 at inlet port 16a, optionally by way of a delivery apparatus 110, such as a pipette or syringe. Motile cells in the sample migrate from receiving well 32 into flow channel 20 toward target chamber 22. The extent of progress of motile cells along the flow channel 20 may
15 serve as an indicator of cellular motility. The migration of motile cells may be detected optically, e.g. either visually or by means of an optical device 70, such as a microscope, through a transparent cover 12 over the flow channel 20 and/or target chamber 22 or through a
20 transparent region of the substrate itself.

To maximize the utility of the devices of the invention, it is important to ensure that any cell movement observed in the flow channel is due to the
25 inherent motility of the cell being assessed. Hence, fluid flow properties in the devices should neither impede nor enhance the movement of cells in the flow channel. Additionally, the flow channels should contain no extraneous material (i.e. particulate or agglomerate
30 material other than the cells of interest) that could impede motility of the cells of interest or obscure visibility of the cells in the flow channels. The devices of the present invention include several modifications and additions to the devices disclosed in
35 U.S. Patent No. 5,296,375, which function to control fluid flow properties in the device flow channel and to exclude extraneous cellular aggregates, gelatinous

bodies, non-cellular particulate material and the like from the flow channels of the device.

5 It has been discovered in accordance with the present invention that sudden bulk ingress of the sample from the receiving well into the flow channel may be minimized by sealing one or more distal access ports, preferably the access port to the target chamber, with sealing tape or another type of sealant. This feature is
10 illustrated in Figure 1, wherein port 16b disposed above and in registry with target chamber 22 is sealed with sealant 30b. This sealing improves the flow properties of the sample through flow channel 20 by minimizing bulk ingress of the sample into the channel, thereby reducing
15 hydraulic shock and the effect thereof on motile cells contained within the sample. As a result, the movement characteristics of the motile cells in the sample can be measured and observed more accurately, without the confounding effects of bulk fluid flow through the flow
20 channel.

In practice, the distal port is initially open to the atmosphere (or attached to an appropriate pressure/suction device) to facilitate filling the
25 channels and chambers with a suitable biological medium. The distal port is then sealed, and a sample containing the motile cells of interest is introduced into the receiving well. After the assay is complete, the seal may be removed. Alternatively, a permanent seal (e.g. a
30 hardening resin or glue) may be used, e.g., in disposable devices designed for single usage.

In addition to sealing the target chamber access port and/or other access ports of the device, the
35 access port disposed over the receiving well may be also be fitted with a removable seal. Sealing the receiving well may be performed to preserve sterility of the device

and/or to contain pre-packaged solutions and reactants in the device. As illustrated in Figure 1 inlet port 16a is covered with a removable seal 30a.

5 It has also been discovered in accordance with the present invention that the flow properties of a motile cell-containing sample in the flow channels of the devices may be further regulated by including in the receiving well a plurality of flow-regulating solids,
10 such as small beads or other particles, sometimes referred to herein as "flow-regulating particles." Flow regulating particles may be comprised of glass, latex beads, or similar particulate material, preferably having a rounded shape and smooth surface, so as to avoid
15 damaging motile cells of interest in the receiving well. Other materials suitable for use in flow-regulating beads include but are not limited to: silica, plastics, organic polymers, metals and metal oxides. The flow-regulating particles improve the flow properties of sample fluid in the flow channels in two ways. First, they function to
20 fractionate the flow pattern of the sample fluid added to the receiving well, thereby further reducing ingress of bulk sample into the channel. Second, the particles function to restrict entry into the flow channel of
25 cellular aggregates, large particles, gelatinous material and the like, so that only the motile cells of interest enter the flow channel. This enables the motile cells of interest to proceed along the flow channel unimpeded by extraneous material originally present in the sample, and
30 also facilitates visual observation of the cells by eliminating material from visual inspection regions that could obscure viewing of the motile cells.

 A device that includes flow-regulating
35 particles is illustrated schematically in Figure 1. As can be seen in Figure 1, inlet port 16a and receiving well 32 together contain flow-regulating particles 42.

It will be appreciated that flow-regulating particles 42 should be of a size and shape to enable passage between the particles of the motile cells of interest, but entraining, and thereby restricting from the flow channel, larger cell aggregates, gelatinous material, non-cellular particulate matter, and similar materials that may be present in the sample. Thus, the size and shape of the flow-regulating particles should be selected with reference to the motile cell types to be tested in the devices of the invention. Accordingly, glass or latex beads, which may be fabricated to varying sizes, are particularly suitable for use as flow-regulating particles.

In another embodiment, flow from the receiving well in the flow channel is regulated by flow-regulating structure instead of, or optionally in addition to, flow-regulating particles. Figure 3 schematically illustrates a face view of receiving well 32, microfabricated to comprise a series of flow-regulating structures 44, fabricated in the receiving well adjacent to flow channel 20. These flow-regulating structures 44 function in a manner equivalent to the flow-regulating particles described above, in that they fractionate the flow of the sample fluid, thereby reducing bulk ingress of sample fluid into the channel, and the also entrain large cellular aggregates, gelatinous material, etc, thereby excluding it from the flow channel. The flow-regulating structure 44 is of a size that enables passage of the motile cells of interest into the flow channel, but impedes larger particulate matter.

In another embodiment, devices of the invention may also be fabricated with mesoscale filters, such as those described in commonly owned U.S. Patent No. 5,296,375, at the mouth of a flow channel. The mesoscale filter may either replace or supplement flow-regulating

beads or structures. A device having a flow channel in which is disposed mesoscale filter 24 is diagrammatically illustrated in Figure 1 and Figure 2A.

5 To ensure a high density of motile cells entering the flow channels, the base of the receiving well may be fabricated with a series of parallel flow-guiding ribs sometimes referred to herein collectively as "cell directors." The flow-guiding ribs orient motile
10 cells and guide their entry into the flow channel. Without such a device fashioned into the receiving well, it has been found that sperm and other motile cells tend to swim into the corners of the receiving well, rather than entering the flow channel. One embodiment of a
15 device having a receiving well with cell directors is shown in Figure 2B. Substrate 14 in Figure 2B shows receiving well 32 fabricated with flow-guiding ribs 34 directing motile cells into flow channel 20. Another embodiment of a device utilizing cell directors is shown
20 in Figure 2A. Figure 2A shows substrate 14 fabricated with receiving well 32 having a series of parallel flow-guiding ribs 34, which direct motile cells into two flow channels 20 at opposing ends of receiving well 32.

25 In another embodiment, a preparative device may be fabricated for separating and collecting motile cells on the basis of their comparative mobilities. A preparative motile cell collecting chip is particularly useful for collecting sperm of various motilities. Such
30 a device is shown schematically in Figure 4. Device 10 comprises a substrate 14 having a receiving well 32 and a target chamber 22, connected by a tortuous flow channel 20. It is again noted that target chamber 22 may be omitted from the device. Depending on the type of motile
35 cell being prepared, the flow channel may comprise square corners (i.e. corners at right angles), or alternatively, the corners may be somewhat rounded, such that the flow

channel is serpentine in nature. Device 10 further comprises a cover 12, which is clamped or otherwise bonded to substrate 14. Cover 12 is fabricated with access ports 16, which register with the flow channel 20 at selected positions. Additionally, access ports 16 are aligned over and register with receiving well 32 and target chamber 22. One or more of the access ports 16 may be sealed with, e.g., sealing tape or a resin (not shown) before or during use of the device. In practice, a sample containing motile cells, such as sperm, is introduced into the receiving well. Thereafter, motile cells enter the flow channel, migrating along the flow channel to the target chamber. During a pre-determined time period, cells having greater motility will migrate further along the flow channel, such that motile cells become dispersed along the flow channel at various distances from the target chamber, depending on their relative motilities. Samples containing motile cells at various positions along flow channel 20 may be removed via any of the access ports 16b, for analysis or further use.

In another embodiment of the present invention, multiplicate cell motility assay chips are provided to improve the accuracy of cell motility assessment and to expand the scope of utility of the devices of the invention to a wider variety of assays. As illustrated in Figures 5-7, a substrate 14 is fashioned with a multiplicity of flow channels 20 (2,3,4, or more) extending from a single receiving well 32 and optionally terminating in target chambers 22. In the embodiment shown in Figure 5, the flow channels 20 do not terminate in target chambers. In the embodiment shown in Figure 6, one or more flow channels 20 may terminate in a common target chamber 22. In Figures 5 and 6, the receiving wells 32 are configured in a generally quadrilateral or rhombic form, whereas in Figure 7, the wells 32 have a

generally hourglass shape, whose diverging portions direct the sample into the multiple flow channels 20. One or more of the receiving wells may include a "cell director" comprising flow-guiding ribs. In practice, a single sample is applied to receiving well 32, and the motile cells thereafter migrate through identical channels 20, enabling multiple replication of a single assay and generation of an experimental result reflecting the mean value of the replicated assay. In another embodiment, multiplicate cell motility cell assay devices may be used for comparatively evaluating one or more test compounds for the ability to attract or repel a specified type of motile or chemotactic cell. In this embodiment, the test compound (and suitable controls) are placed in an array of target chambers 22, each connected by a flow channel 20 to a single receiving well 32. Assays are initiated by placing a sample of the selected cell type into the receiving well. Test compounds are evaluated relative to their ability to impede or enhance motility of the selected cell type.

In an alternative embodiment, a selected array of motile or chemotactic cells may be evaluated for their response to a single test compound. In this embodiment, the respective target chambers of the device are utilized as receiving wells for the array of motile cells and the receiving well is utilized as a target chamber (i.e. the typical flow pattern is reversed). In this embodiment, the target chambers are preferably fabricated with flow guiding ribs, while the receiving wells need not be. Samples containing the motile or chemotactic cells to be tested are applied to target chambers 22, and the assay is initiated by placing a sample of the test compound into receiving well 32. The effect of the test compound on the motility of the selected motile or chemotactic cells is then evaluated by then observing movement of those cells through the flow channel from the target

chambers 22 to receiving well 32.

Although multiplicate cell motility assay chips having identical channels are illustrated in Figures 5-7, it will be appreciated by those skilled in the art that devices having channels of different configurations or lengths may also be constructed, to perform other comparative motile cells assays.

Devices of the invention may be designed for selectively separating, and optionally collecting, a selected population of motile cells on the basis of physical or chemical characteristics of the cells. Such physical or chemical characteristics include, but are not limited to, motility, size, movement in an electrical field, surface morphology (e.g., possession of unique surface antigens), and the like. In a preferred embodiment, devices are designed to selectively separate, and optionally collect, enriched populations of sperm containing male (Y) or female (X) sex chromosomes referred to as "Y" or "X" sperm. It is known that Y sperm tend to swim slightly faster than X sperm due to the slightly reduced weight of the truncated Y chromosome. Accordingly, sperm populations enriched in the Y chromosome may be separable from X chromosome-enriched sperm populations on the basis of motility. Other morphological features that can be used to selectively separate Y from X sperm include differing density, differing motility behavior in an electric field (Y sperm migrate preferentially to the anode) and potentially different and/or unique surface antigens. Accordingly, various separation techniques may be adapted for use in devices of the invention, including, but not limited to: immunoaffinity separation, electrophoresis, gel filtration and density gradient separation.

Substrates fabricated for various sperm selection devices are shown schematically in Figures 8, 9A, and 9B. Figure 8 shows a substrate 14 that includes receiving well 32 and target chamber 22, connected by a multi-component flow channel comprising a tortuous section 20a and selection section 20b. In this embodiment, the tortuous section 20a typically is fabricated with rounded corners to form a serpentine configuration. The selection section 20b of the flow channel is designed to select a specific cell population (i.e. X versus Y sperm) on the basis of one or more additional chemical or physical features. In one embodiment, an electric field is applied to the selection section of the flow channel, in such a manner that motility of the already faster Y sperm along the flow channel is further enhanced (e.g., by placing the anode proximal to the target chamber) such that the target chamber will include a male chromosome-enriched sperm population. The electric field is applied across the length of the selection section 20b by inserting electrodes into access ports at each end of the selection section; cell movement is then induced by applying the electric field.

In another embodiment illustrated in Figures 9A and 9B, the selection section 20b of the flow channel contains a coating in at least a portion thereof, of a capture or restraining agent, such as an antibody directed to a unique surface antigen of one cell population desired to be enriched. For example, the selection section may be coated with an antibody against cell surface antigen specific for X or Y sperm, such that this sperm population is restrained in the selection section, while the unrestrained sperm proceed to target chamber 22. In an alternative embodiment, illustrated in Figure 9b, the substrate is fabricated with a branch

conduit 20c and second target chamber 22 for collecting a second cell population. For example, X or Y sperm restrained by the capture agent of coating 28 subsequently may be released from the capture agent and diverted through branch conduit 20c to the target chamber 22.

Another example of a preparative motile cell collecting chip is illustrated schematically in Figure 10A, 10B, and Figure 13. Figure 10A shows a device 10, wherein the substrate 14 is fabricated with a receiving well 32 and a target chamber 22a, connected by a modified tortuous flow channel 20, wherein the channel comprises a series of sampling chambers 20b, formed by expanding the symmetrically serpentine tortuous flow channel 20 along the turns of the channel on one side. In a preferred embodiment, the substrate is etched (or otherwise marked) with lines of demarcation and/or reference numbers (or other designations) at various points along the flow path (e.g., at each sampling chamber in the device shown in Figure 10A), for facilitating measurements of cell motility. An enlarged view of a section of flow channel 20 comprising sampling chamber 22b (with reference numbers adjacent thereto) is shown schematically Figure 10B. Figure 10A illustrates a device having three identical flow systems. The device illustrated in Figure 10A comprises the above-described substrate 14 covered by a cover 12, fabricated to include inlet ports 16a and access ports 16b disposed over and in registry with the receiving well, target chamber, and sampling chambers, respectively, at selected locations. Access ports 16b disposed over the tortuous flow channels 20 are arranged such that samples may be removed at various points along the flow path between the receiving well and the target chamber. As illustrated in Figure 10A, which shows a device containing three identical tortuous flow channels and sampling chamber arrays, access ports 16b are offset

over the sampling chambers such that each access port provides access to a different sampling chamber within the channels.

5 An alternative embodiment of a preparative motile cell collecting chip is shown in Figure 13. Figure 13 illustrates a device comprising substrate fabricated with a receiving well 32 and target chamber 22a, connected by a flow channel 20 which branches into a series of sampling chambers 22b. The substrate is covered by a cover 12 fabricated to comprise inlet port 16a and various access ports 16b for accessing the target chamber and various sampling chambers. It should be noted that in all of the multiport devices described above, flow properties of the sample fluid may be improved by sealing some or all of the access ports during the assay.

 It is often advantageous, particularly with reference to sperm analysis, to conduct two or more different types of assays on a single cell sample, preferably simultaneously. Devices of the invention may be fabricated with various configurations and reagents, for the purpose of conducting a plurality of assays on a single sample. A device for conducting multiple assays on a single sperm sample is illustrated in Figure 11 and Figure 12. Device 10 shown in Figure 11 is fabricated with structures for five different sperm tests. Substrate 14 comprises a receiving well 32 connected by a tortuous flow channel 20a to a target chamber 22a, for sperm motility testing. Substrate 14 further comprises another receiving well 32 connected to a target chamber 22a by a non-tortuous flow channel 20b, pre-filled with a hyaluronic acid solution and having various lines of demarcation adjacent thereto, for conducting a sperm penetration test. Substrate 14 further contains chamber 22b for conducting a sperm count using a conventional

grid 36. Substrate 14 further comprises chamber 22c in which is disposed, e.g. antibody coated microparticles, for conducting a sperm antibody test. Substrate 14 further contains chamber 22d, which may be pre-filled with a substance such as Resazurin dye, for conducting a sperm vitality test. Cover 12 of device 10 shown in Figure 11 is shown in full in Figure 12. As can be seen in Figure 12, cover 12 is fabricated with various inlet ports and access ports, in registry with the wells and chambers of substrate 14, for adding samples and reagents to the multiple sperm testing device 10. In practice, a small sample of liquified semen is applied to the different test areas on the chip. After a few minutes, the results of each test is assessed visually, using, e.g. a microscope at, e.g., 600x magnification. Results would be available within a few minutes, thereby permitting an attending physician or clinician to report and/or select an appropriate course of action during the course of an office visit by a patient.

20

In another embodiment, the devices of the invention may be utilized to perform an *in vitro* fertilization, which advantageously may be conducted in a small, portable controlled environment chamber (i.e. an incubator). Embodiments of *in vitro* fertilization devices and a portable incubator are shown in Figures 14-16. Device 10 in Figure 14 includes a substrate 14 into which is fabricated a receiving well 32 and a tortuous flow channel 20, terminating in an enlarged target chamber 22 suitable to contain one or more eggs to be fertilized. The device includes a cover 12, which is disposed over the substrate 14, with ports 16a and 16b positioned over the receiving well and target chamber, respectively. An alternative *in vitro* fertilization device is shown in Figure 15. Device 10 in Figure 15 comprises substrate 14, into which is fabricated a dual receiving well 32, from which extend tortuous flow

35

channels 20, which terminate in a target chamber 22a, of sufficient size to contain one or more eggs to be fertilized. Target chamber 22a is in fluid communication with reservoir chamber 22b, which is designed to
5 contained a reservoir of biologically compatible medium for purposes of maintaining appropriate fluid balances in the *in vitro* fertilization device. Disposed between reservoir chamber 22b and target chamber 22a are a series of walls 46 and posts 44 designed to restrain eggs
10 nesting in target chamber 22a (and, to a certain extent, sperm that have entered the target chamber), but to permit fluid communication between the target chamber 22a and the reservoir chamber 22b. The receiving wells 32 of both fertilization devices shown in Figure 14 and 15 are
15 preferably fabricated with cell directors comprising flow-guiding ribs (not shown).

The *in vitro* fertilization chips shown in Figure 14 and 15 may be used in conjunction with a small,
20 portable incubator to controlled ambient conditions for *in vitro* fertilization. An example of such an incubator is shown in Figure 16. As shown in Figure 16, the incubator 80 comprises a substantially airtight chamber having a region for holding the *in vitro* fertilization
25 chips. The incubator 80 is fitted with sensors or other means 94 to detect ambient microenvironmental conditions within the incubator 80, and further comprises one or more valves 92 for filling the chamber with gas of appropriate composition. Alternatively, the incubator 80
30 may be constructed with a chemical gas generating component 88, for purposes of altering or maintaining the gas composition within the incubator. The incubator 80 further comprises a heater 86 and a humidifier 84, both in electronic communication with ambient condition
35 sensing device 94. In practice, an appropriately prepared *in vitro* fertilization chip is placed in the incubator, which has been precharged with fluid and

preheated to an appropriate temperature, e.g., 37°C. The incubator chamber is filled with a gas mixture of the appropriate composition (5% oxygen, 5% carbon dioxide, and 90% nitrogen, for example). The chip is incubated
5 for an appropriate period (e.g. 24 hours) after which eggs are inspected for fertilization and development using an optical device, such as a microscope. Observation of eggs in the target chamber may be accomplished directly through the top of the incubator
10 lid, which is preferably comprised of a transparent material, thereby causing minimal distress to the developing embryo. Alternatively, the lid may be raised by a handle 96 to provide direct access to the device.

15 The invention will be understood further from the following nonlimiting examples.

Example 1

20 Sperm motility was assessed using a device 10 of a type shown schematically in Figure 10A. Specifically, substrate 14 of the device included receiving wells 32 and target chambers 22a, which consisted of 40 μ m-deep square troughs (2 x 2 mm and 1 x 1
25 mm, respectively), connected by sample flow channels 20 (100 μ m wide x 40 μ m deep), adapted to comprise sampling chambers 22b. The substrate was covered with a Pyrex glass cover, having holes drilled through it, positioned above and registered with the receiving wells 32 and
30 target chambers 22 (holes in the glass cover in registry with various sampling chambers were optionally included in some devices). The substrate was comprised of a silicon wafer 400 μ m in thickness. Masks for the fabrication process were made by Align-Rite (Santa Clara,
35 CA). The silicon wafers used for the substrate (approximately 10 cm in diameter) were etched by Micrel Semiconductor (San Jose, CA) and diced into 17 x 14 mm

chips by the Alberta Microelectronics Centre (Edmonton, Alberta, Canada) Pyrex glass tops with appropriate holes drilled therein (obtained from Mooney Precision Glass, Huntington WV) were bonded to the substrate by use of a
5 diffusive bonding process (G. Wallis, J. Am. Ceram. Soc., 53: 563-567, 1970). The circular chambers formed by the holes through the glass above the receiving wells were 4.22 μ l in volume, and the holes disposed above the target chambers were of a volume of 1.55 μ l.

10

The channels and chambers of the device were pre-filled with HEPES-buffered human tubal (HTF) medium (Irvine Scientific, Santa Ana, CA) containing 5 g/l bovine serum albumin (Cohn Fraction V, Sigma Chemical
15 Co., St. Louis, MO) (HTF/BSA). Next, a 2- μ l sample of liquified semen was introduced into the receiving wells 32 by pipette. The progression of sperm into the channels was then monitored with a microscope (Aristomet, Wild Leitz, Heerbrugg, Switzerland) and recorded with a
20 black-and-white television camera (Dage-MTI, Michigan City, IN) and a video cassette recorder (PVM-122, Sony, Teaneck, NJ). A numerical scale (10 to 1 in the direction from the receiving well to the target chamber) was etched into the silicon next to the channels to
25 facilitate semiquantitative assessment of the progression of sperm along the channels. Sperm progression was observed at five minute intervals from 0-25 minutes.

Sperm were detected in the entrance to the flow
30 channel (scale position 10) within a few minutes; by 25 minutes, a large population of motile sperm were distributed along half the length of the channel (scale points 10 to 6). The sperm may optionally be removed from various points along the flow channels and chambers
35 through access ports 16a and 16b, disposed over the target chambers 22a and various sampling chambers 22b.

Example 2

In another procedure, a device 10 of a type shown schematically in Figure 4 was used to test a series of three semen samples previously analyzed and graded as having normal, borderline, and abnormal mobility, respectively. Assay procedures for this example were the same as those described for Example 1 above.

The comparative migration distances of the sperm along the channel 20 reflected the previous gradation of the sperm samples as normal, borderline, abnormal. The normal sperm sample migrated farthest along the channel, while the borderline sperm sample migrated less far and the abnormal sperm sample migrated the least distance.

Example 3

Sperm motility was assessed and compared using a tortuous-channeled device 10 of a type shown schematically in Figure 4 and a straight-channeled device similar to the straight channel portion of the multiple assay device 10 shown in Figure 11. As described above, the flow channels were pre-filled with HTF/BSA medium and samples of liquified semen ($2\mu\text{l}$) were applied to receiving wells 32. The sperm were then allowed to swim into the channels 20 for 10 minutes, then the number of sperm at specific locations in each channel was determined. For the straight channel design, sperm were monitored at a position $840\mu\text{m}$ linearly distant (no right-angled turns) from the receiving well. For the tortuous channel design, sperm were monitored $3100\mu\text{m}$ from the receiving well, i.e., after they had negotiated two right-angled turns. As expected, the number of sperm swimming via the tortuous pathways to the more distant observation point was fewer than via the short linear

channel.

Example 4

5 An *in vitro* fertilization is performed using an
in vitro fertilization chip of the type illustrated in
Figure 15, in an incubator of the type illustrated in
Figure 16. The *in vitro* fertilization chip 10 is filled
10 HTF BSA and an egg or eggs are placed in the enlarged
target chamber 22a. A small sample of washed semen
(e.g., 1 μ l) is added to the receiving well 32. The chip
10 is then place in the microincubator 80, which has been
precharged with fluids and preheated to 37°C. The
incubator chamber is filled a gas mixture comprising 5%
15 oxygen, 5% carbon dioxide, 90% nitrogen. The chip 10 is
incubated for approximately 24 hours, and the eggs
thereafter inspected for fertilization and development.
Inspection of the eggs is accomplished by visualizing
target chamber 22b directly through the top of the
20 incubator lid, which is comprised of transparent
material, thus causing minimum distress to the developing
embryo.

 In another procedure, carbon dioxide is
25 generated in the incubator chemically, by mixing
hydrochloric acid and a biologically compatible carbonate
or bicarbonate salt (e.g. sodium bicarbonate), thereby
producing carbon dioxide gas within the incubator.

30 While certain preferred embodiments of the
present invention have been described, illustrated and
specifically exemplified above, it is not intended be
limited to such embodiments, various modifications may be
made thereto without departing from the scope and spirit
35 of the present invention, as set forth in the following
claims.

What is claimed is:

1. A device for analyzing a sample having cells characterized by their motility, the device
5 comprising:
a solid substrate having a flow system which comprises at least one elongate flow channel of mesoscale cross-sectional dimension, and a receiving well communicating with said channel and defining a starting
10 point in said channel; and
a cover for said substrate closing said channel and having a port in registry with said receiving well, for introducing said sample into said receiving well so as to enable the motile cells of the sample to
15 travel from the receiving well to progress points along the channel, said cover defining a second port to said channel at a point therealong.
2. The device of claim 1, wherein said second
20 port comprises a hole in said cover in registry with said channel at a point therealong.
3. The device of claim 1, wherein said point
25 along said channel is a point distal to said receiving well.
4. The device of claim 1, wherein said channel
30 extends to an edge of said substrate and said port is formed at said edge upon closing said channel with said cover.
5. The device of claim 1, wherein at least one
35 of said substrate and said cover comprises a material selected from the group consisting of glass, silicon, silica, polysilicon, silicon nitride, silicon dioxide, plastic and organic polymeric material.

6. The device of claim 1, wherein said mesoscale flow channel has a cross-sectional dimension between about 0.1 and 1,000 μm .

5 7. The device of claim 1, wherein said mesoscale flow channel has a depth less than about 500 μm .

10 8. The device of claim 1, wherein said progress points in said channel are observably marked.

9. The device of claim 1, wherein said channel is a tortuous channel.

15 10. The device of claim 1, wherein said flow system contains a carrier fluid comprising a medium compatible with said cells.

20 11. The device of claim 10, wherein said cells are sperm cells and said medium is selected from the group consisting of mammalian tubal fluid, cervical mucus, hyaluronic acid, buffer, or a combination thereof.

25 12. The device of claim 11, wherein said channel is of a width sufficient to permit unrestrained tail movement of said sperm cells.

30 13. The device of claim 12, wherein said sperm cells are human sperm cells and said channel is between about 100 μm and 200 μm in width.

35 14. The device of claim 1, wherein said flow system further comprises a target chamber communicating with said channel and defining a terminating point in said channel.

15. The device of claim 14, wherein said second port is in registry with said target chamber.

5 16. The device of claim 1, wherein said second port includes a seal for sealing said second port during introduction of said sample into said receiving well.

10 17. The device of claim 1, wherein said receiving well further includes a plurality of flow-regulating solids having a size and shape effective to permit passage of said motile cells, in non-aggregated form, from said receiving well into said channel and concomitantly to substantially restrain passage into said channel of selected particulate matter in said sample.

15 18. The device of claim 17, wherein said flow-regulating solids are particles added to the receiving well.

20 19. The device of claim 18, wherein said particles are beads comprised of materials selected from the group consisting of glasses, silica, plastics, latex materials, organic polymers, metals and metal oxides.

25 20. The device of claim 17, wherein said flow-regulating solids comprise an array of projections fabricated in the substrate at a position in the receiving well adjacent to the communicating terminus of said channel.

30 21. The device of claim 1, wherein said receiving well further includes a cell director comprising flow-guiding ribs longitudinally aligned with said channel, for directing said motile cells from said receiving well into said channel.

22. The device of claim 1, wherein said cover defines at least one additional port in registry with at least one said progress point along said channel, thereby providing access to said motile cells disposed in said channel at said progress point.

23. The device of claim 1, wherein said flow system further comprises at least one sampling chamber disposed along said channel at said progress points, in fluid communication with said channel.

24. The device of claim 23, wherein said cover defines at least one additional port in registry with said at least one sampling chamber.

25. The device of claim 1, which comprises a plurality of said flow system.

26. The device of claim 25, wherein at least one of said plurality of flow systems includes a tortuous flow channel and at least one other of said plurality of flow systems includes a straight flow channel.

27. The device of claim 1, wherein said flow system further comprises at least one receiving well in communication with a multiplicity of mesoscale flow channels.

28. The device of claim 27, wherein said channels are identical.

29. The device of claim 1, wherein said channel comprises a selection region, said selection region being adapted for selective separation of at least one motile cell type from a mixed population of cell types.

30. The device of claim 29, wherein said selection region comprises a capture agent which selectively binds said at least one cell type.

5 31. The device of claim 29, wherein said selection region comprises an electric field which selectively influences motility of said at least one cell type.

10 32. The device of claim 1, which further comprises a detection system for detecting progress of said motile cells in said flow system.

15 33. An apparatus for performing an *in vitro* fertilization, which comprises:
 a device having:
 a solid substrate having at least one elongate flow channel of mesoscale cross-sectional dimension;
20 a receiving well communicating with said channel and defining a starting point in said channel;
 an egg nesting well communicating with said channel and defining a terminating point in
25 said channel; and
 a cover for said substrate closing said channel and having a port for introducing a sperm sample into said receiving well to enable said sperm to travel from said receiving well through said channel to
30 said egg nesting well, said cover further comprising a second port in registry with said egg nesting well;
 said device being disposed in a portable, sealable, environmental control chamber comprising a holding region for holding said device.

35 34. The apparatus of claim 33, wherein said environmental control chamber further comprises at least

one of

an atmosphere producing system for producing an atmosphere in said chamber conducive for said *in vitro* fertilization;

5 a temperature regulator for controlling temperature within said chamber; and

a humidity controller for controlling humidity within said chamber.

10 35. The apparatus of claim 33, which further comprises a non-intrusive observation system for observing said *in vitro* fertilization within said apparatus while permitting said apparatus to remain sealed.

15

36. The apparatus of claim 35, wherein said non-intrusive observation system comprises:

20 said device wherein at least one of said substrate and said cover, in a portion thereof defining said egg nesting well, is transparent to energy rays in a given spectrum;

said environmental control chamber comprising a lid which is transparent to said energy rays; and

25 a viewing appliance positioned in viewing proximity to said egg nesting well, for viewing said *in vitro* fertilization through said transparent lid and said transparent portion of said device.

30 37. A method of analyzing a fluid sample having cells characterized by their motility, comprising:

a) providing a device comprising:

35 a solid substrate having a flow system which comprises at least one elongate flow channel of mesoscale cross-sectional dimension, and a receiving well communicating with said channel and defining a starting point in said channel; and

- a cover for said substrate closing said channel and having a port in registry with said receiving well, for introducing said sample into said receiving well so as to enable the motile cells of the sample to travel from the receiving well to progress points along the channel, said cover further defining a second port in registry with said channel at a point therealong, said flow system being filled with a carrier fluid;
- 5
- b) introducing said sample into said receiving well;
- 10
- c) controlling the resident conditions of the combined carrier fluid and sample to assure motility of said cells in said carrier fluid;
- 15
- d) observing the cells in the flow system;
- e) collecting data based on said observation; and
- f) completing the analysis using said data.
- 20

38. A method according to claim 37, wherein said resident conditions are controlled by sealing said second port of said device prior to introducing said sample into said receiving well.

25

39. A method according to claim 37, wherein said resident conditions are controlled by providing in said receiving well a plurality of flow-regulating solids, said flow-regulating solids having a size and shape effective to permit passage of said motile cells, in non-aggregated form, from said receiving well into said channel and concomitantly to substantially restrain passage into said channel of selected particulate matter in said sample.

30

35

40. A method according to claim 37, wherein

said resident conditions are controlled by providing in said receiving well a cell director comprising flow-guiding ribs longitudinally aligned with said channel, for directing said motile cells from said receiving well
5 into said channel.

41. A method according to claim 37, which further includes generating replicate sets of said data, by a method comprising:

- 10 a) providing said device, which further comprises a plurality of identical flow systems; and
b) performing the method of claim 37 simultaneously in each of said plurality of flow systems, thereby generating said replicate sets of data.

15

42. A method according to claim 37, which further includes conducting a plurality of analyses on a single sample, said method comprising:

- 20 a) providing the device of claim 37, which further comprises a multiplicity of non-identical flow systems designed for said plurality of analyses, each said flow system being filled with a carrier fluid optionally containing reagents for each said analysis;
b) introducing an aliquot of said single
25 sample into said receiving well of each said flow system;
c) controlling the resident conditions of each said combined carrier fluid and sample to assure motility of said cells in said carrier fluid;
d) observing the cells in each said flow
30 system;
e) collecting data based on said observations; and
f) completing the plurality of analyses using said data.

35

43. A method according to claim 37, which further includes selectively collecting at least one

motile cell type from a sample comprising a mixed population of cell types, said method comprising:

5 a) providing the device of claim 37, wherein said channel comprises a selection region, said selection region being adapted for selective separation of said at least one motile cell type from said mixed population of cell types;

10 b) introducing said sample into said receiving well, whereafter said mixed population of cell types migrates through said selection region of said channel, resulting in said selective separation of said motile cell type from said mixed population of cell types; and

15 c) collecting said separated motile cell type.

44. A method according to claim 43, wherein said selection region comprises a capture agent which selectively binds said at least one cell type.

20

45. A method according to claim 43, wherein said selection region comprises an electric field which selectively influences motility of said at least one cell type.

25

46. A method according to claim 43, adapted for selectively separating male chromosome-containing sperm from female chromosome-containing sperm, wherein said sample is a sperm sample and migration of sperm therein through said selection region results in substantial separation of a population of said male chromosome-containing sperm from a population of said female chromosome-containing sperm, at least one of said populations being collected.

30

47. A method of performing an *in vitro* fertilization, comprising:

35

a) providing a device comprising:
a solid substrate having at least one
elongate flow channel of mesoscale cross-sectional
dimension;

5 a receiving well communicating with
said channel and defining a starting point in said
channel;

an egg nesting well communicating
with said channel and defining a terminating point in
10 said channel; and

a cover for said substrate closing
said channel and having a port for introducing a sperm
sample into said receiving well to enable said sperm to
travel from said receiving well through said channel to
15 said egg nesting well, said cover further comprising a
second port in registry with said egg nesting well, said
device containing an *in vitro* fertilization medium;

b) introducing at least one egg into said
egg nesting well;

20 c) introducing a sperm sample into said
receiving well; and

d) placing said device into a portable,
sealable, environmental control chamber for a time and
under conditions effective to enable said sperm to travel
25 to said egg and to fertilize said egg.

48. A method according to claim 47 wherein
said device is placed in said environmental control
chamber that further comprises at least one of

30 an atmosphere producing system for
producing an atmosphere in said chamber conducive for
said *in vitro* fertilization;

a temperature regulator for controlling
temperature within said chamber; and

35 a humidity controller for controlling
humidity within said chamber.

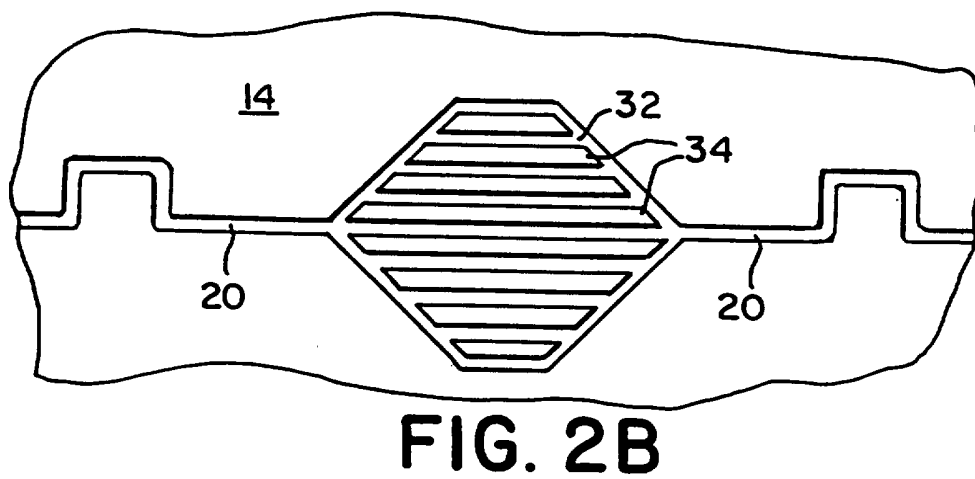
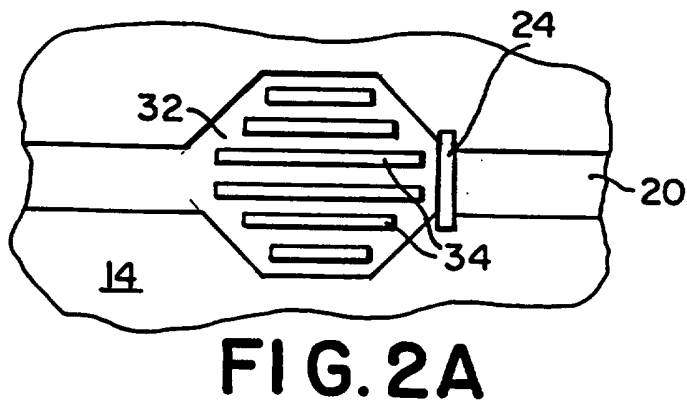
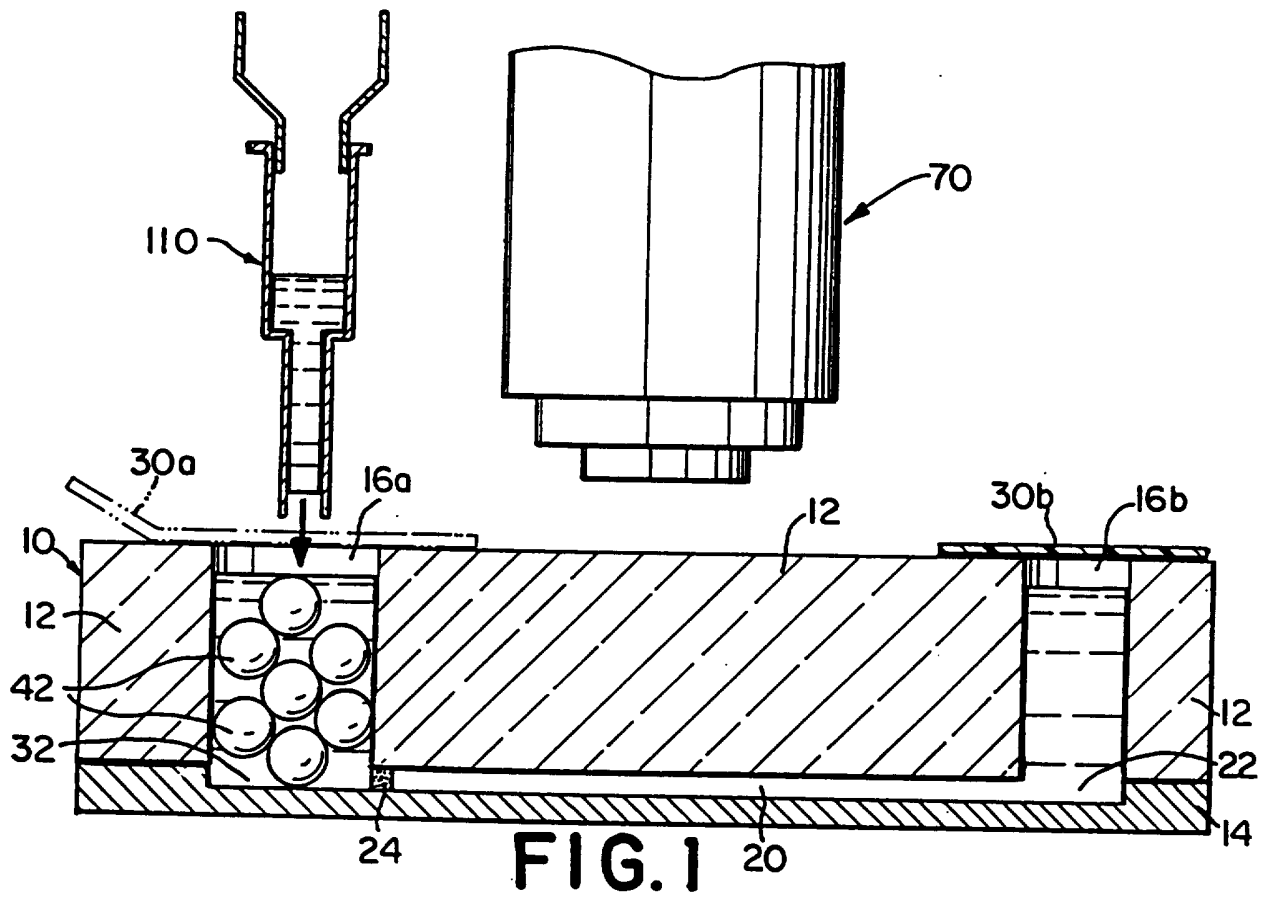

FIG. 4

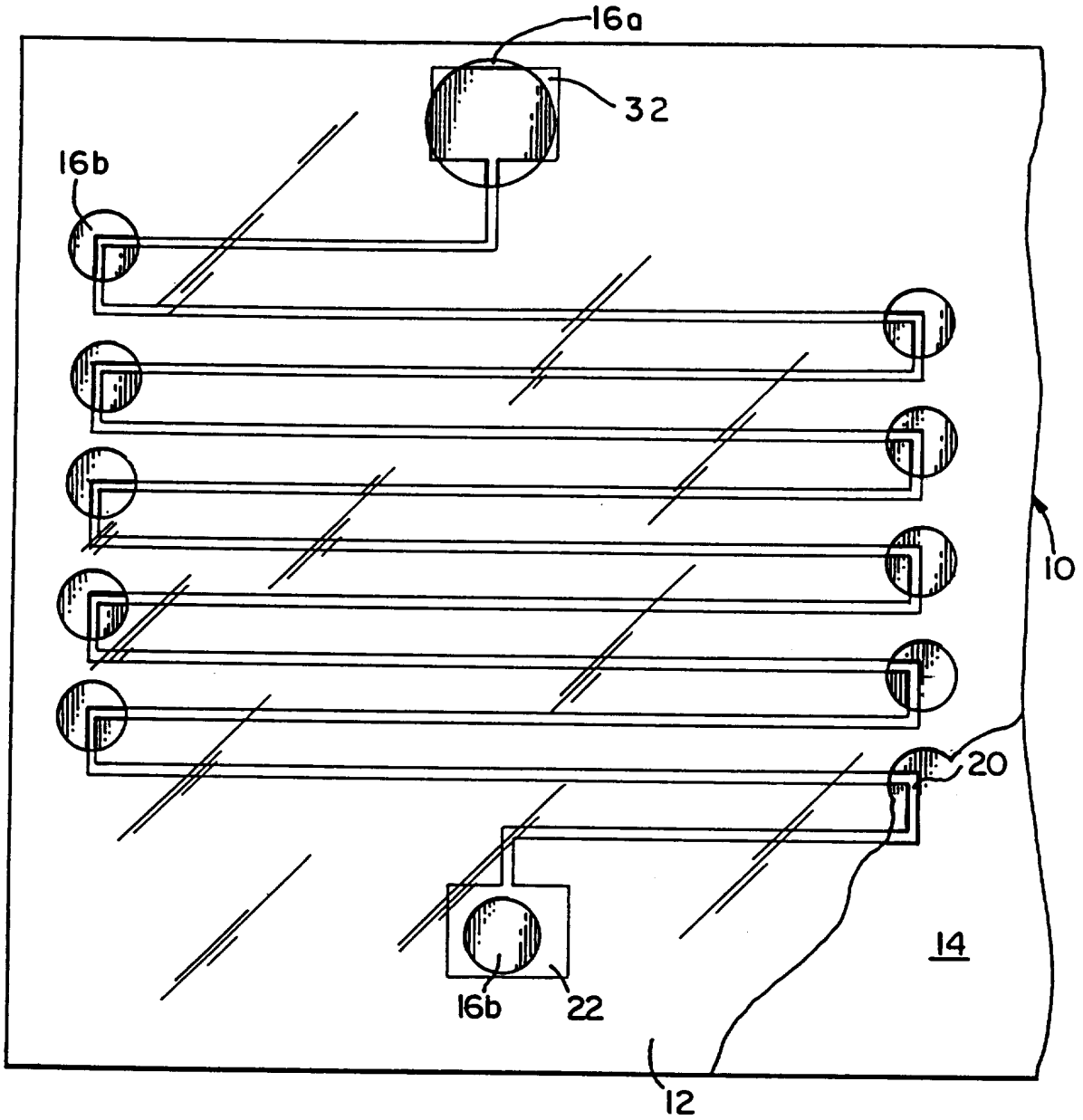
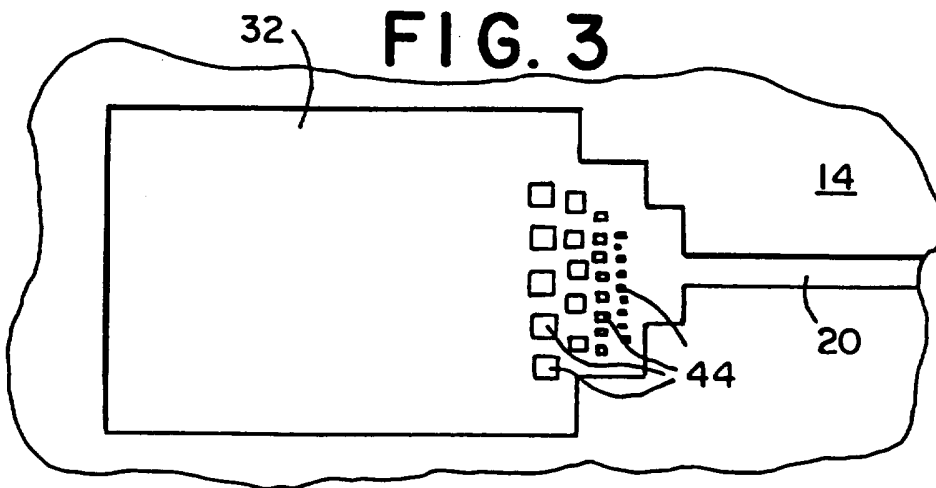

FIG. 3



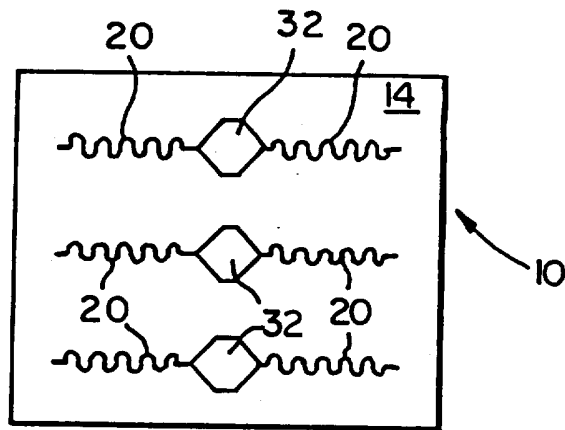

FIG. 5

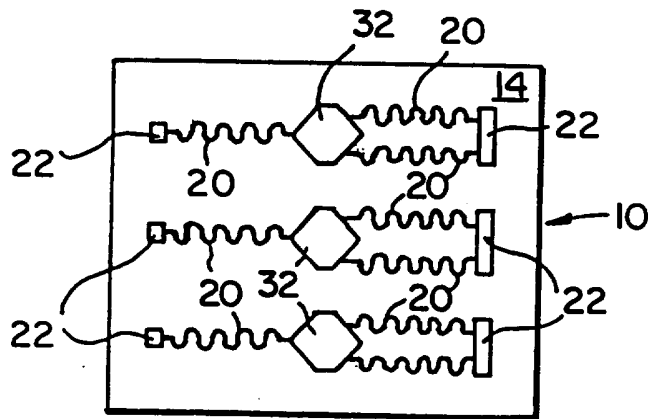

FIG. 6

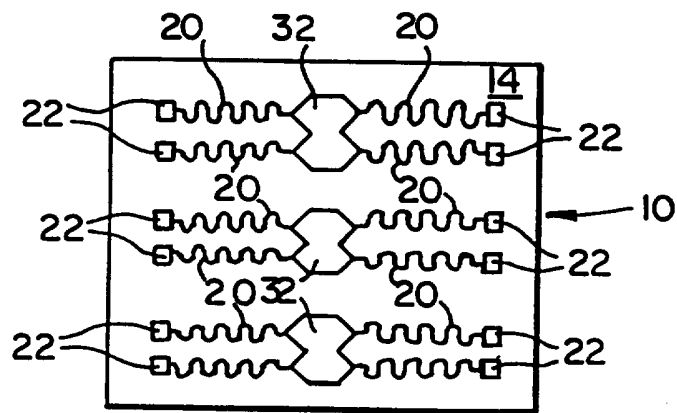

FIG. 7

FIG. 8

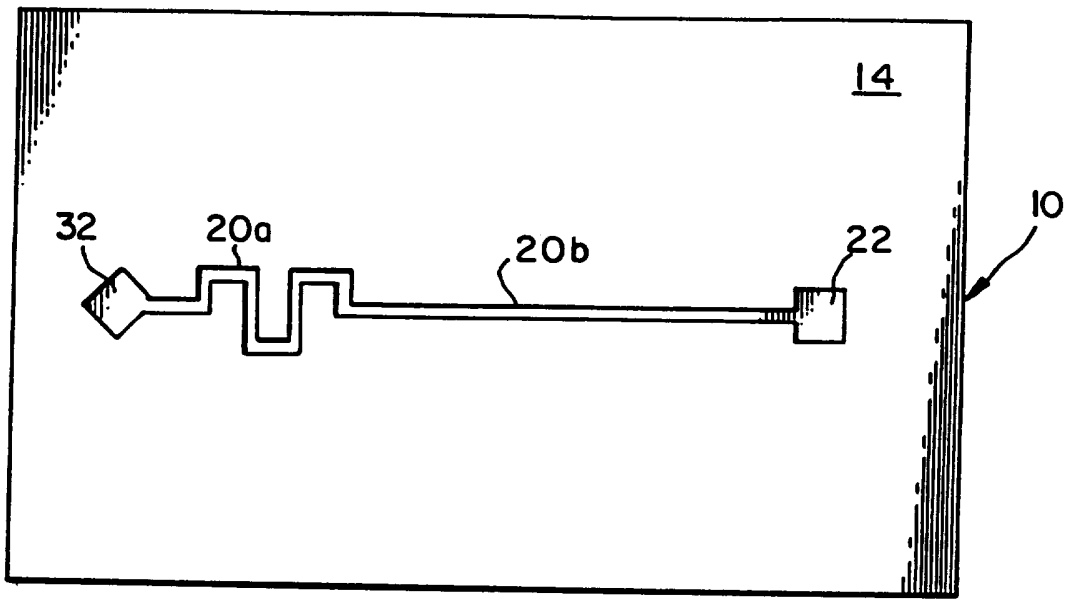

FIG. 9A

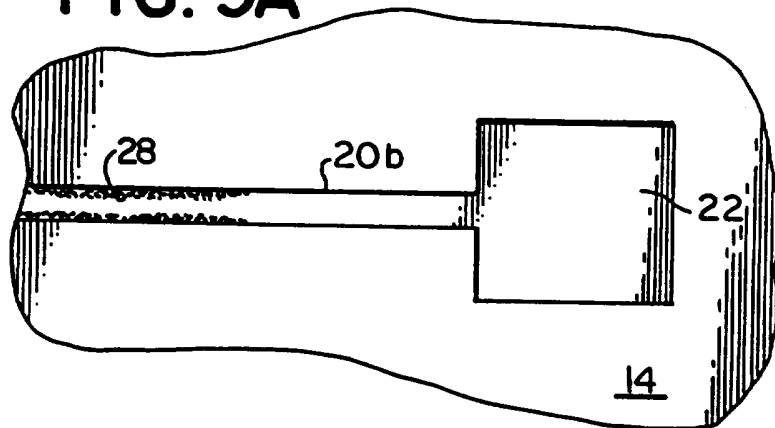
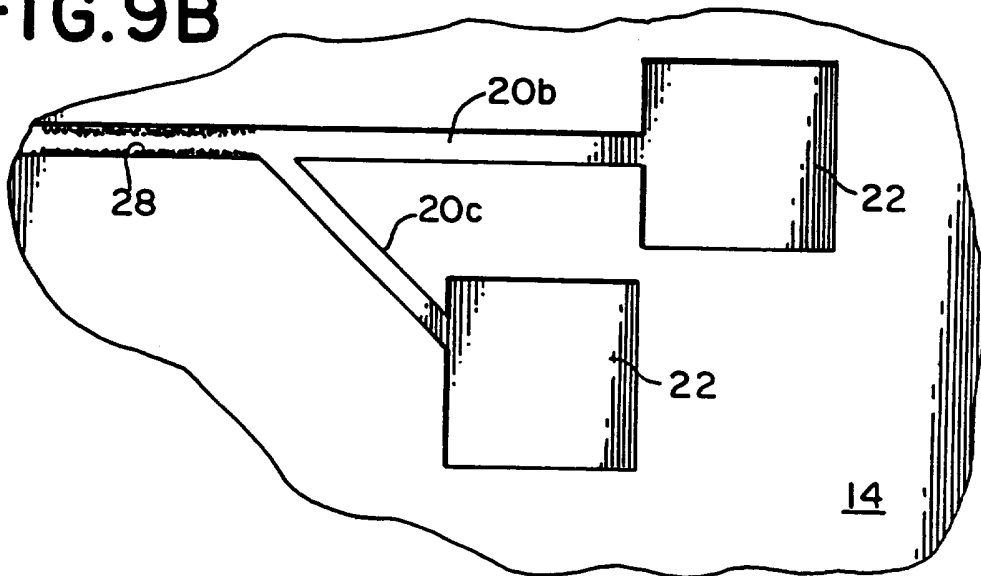

FIG. 9B



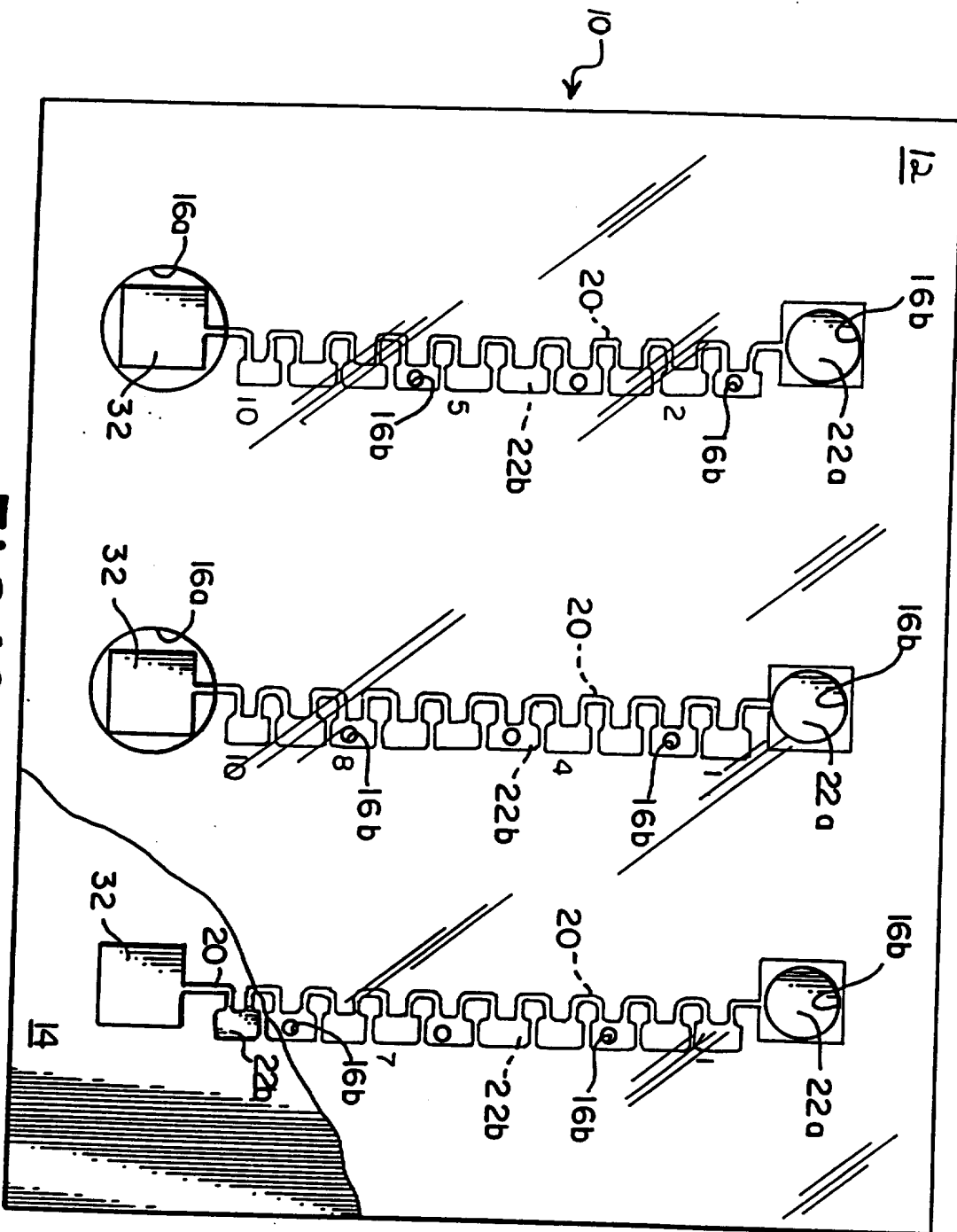

FIG. 10A

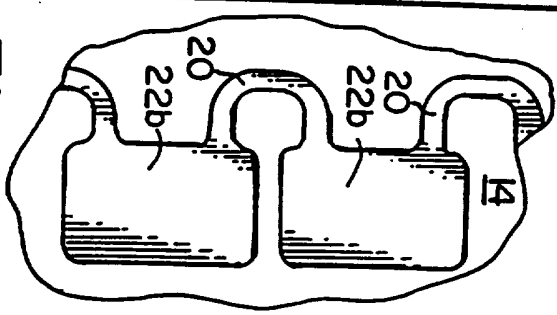

FIG. 10B

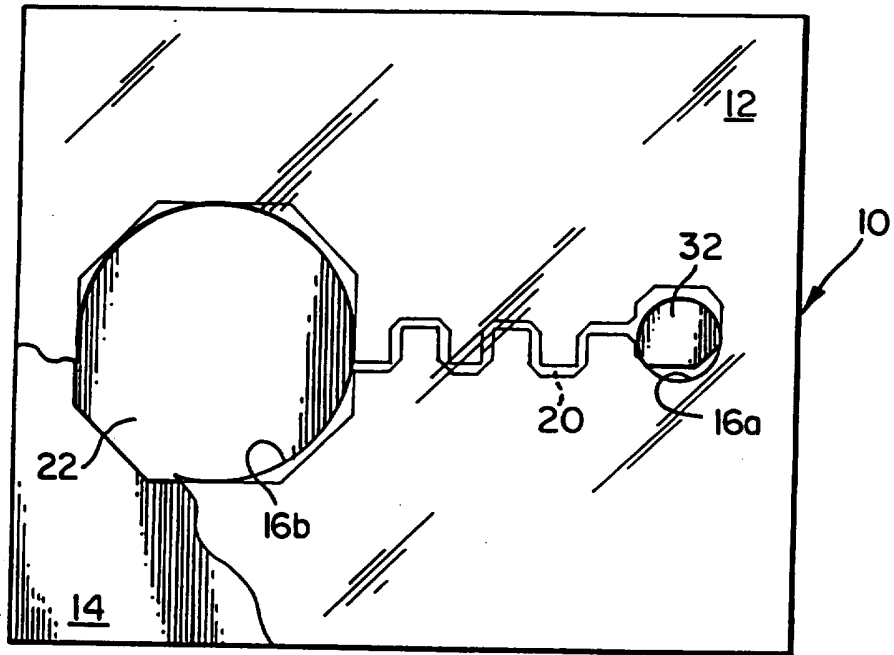

FIG. 14

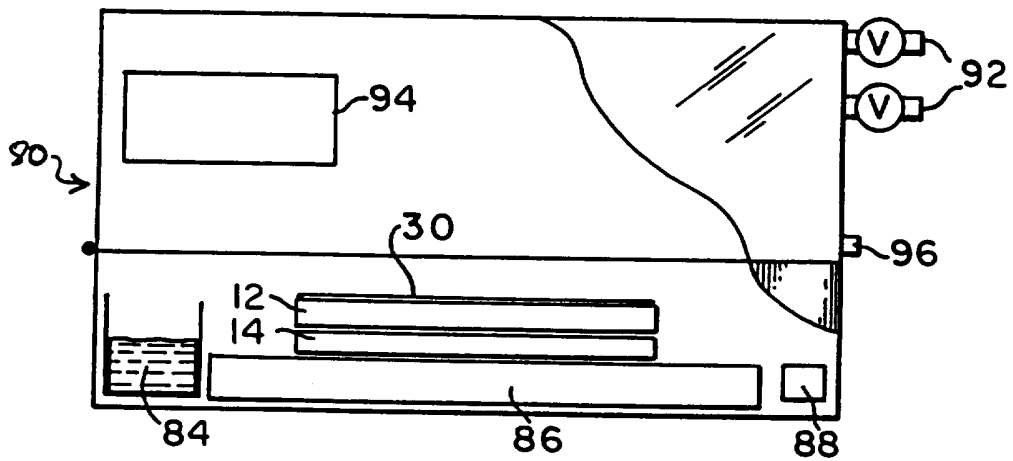

FIG. 16

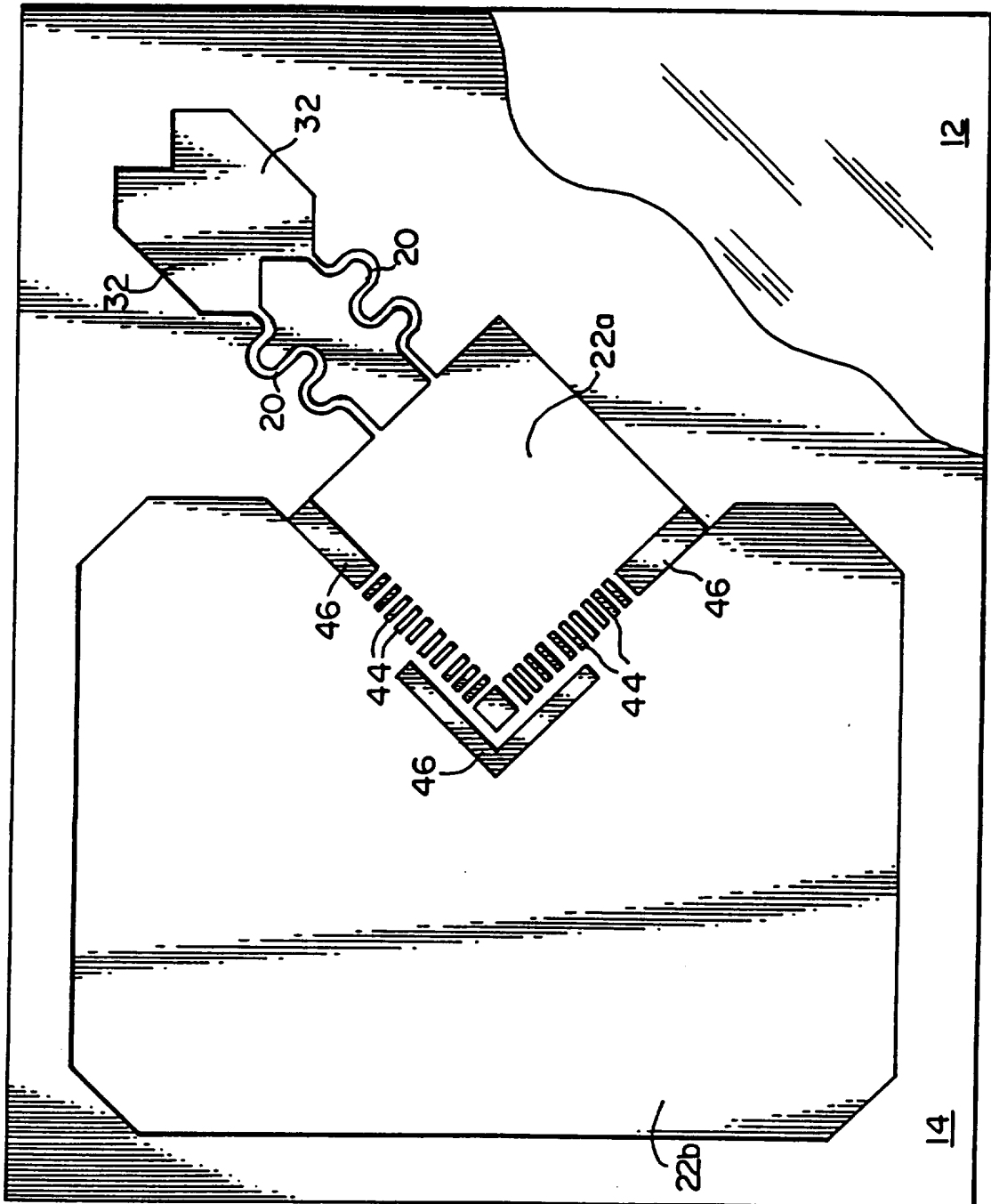

FIG. 15

INTERNATIONAL SEARCH REPORT

Intern. Application No.
PCT/US 95/14824

A. CLASSIFICATION OF SUBJECT MATTER
 IPC 6 B01L3/00 A61D19/00 C12M3/04 A61K35/52

According to International Patent Classification (IPC) or to both national classification and IPC

B. FIELDS SEARCHED

Minimum documentation searched (classification system followed by classification symbols)
 IPC 6 B01L

Documentation searched other than minimum documentation to the extent that such documents are included in the fields searched

Electronic data base consulted during the international search (name of data base and, where practical, search terms used)

C. DOCUMENTS CONSIDERED TO BE RELEVANT

Category *	Citation of document, with indication, where appropriate, of the relevant passages	Relevant to claim No.
X	WO,A,93 22421 (TRUSTEES OF THE UNIVERSITY OF PENNSYLVANIA) 11 November 1993 cited in the application	1-15,17,20,25-29,32,39
Y	see page 5, line 23 - line 32	16,21,30,31,38,40,41,44-46
X	see page 20, last paragraph - page 21, paragraph 1 see page 17, paragraph 2 - page 18, paragraph 1 see page 20, line 1 see page 23; example 4	33-37,47,48
X	see figure 9; example 3 see example 10	42,43
	---	-/--

Further documents are listed in the continuation of box C.

Patent family members are listed in annex.

* Special categories of cited documents :

"A" document defining the general state of the art which is not considered to be of particular relevance

"E" earlier document but published on or after the international filing date

"L" document which may throw doubts on priority claim(s) or which is cited to establish the publication date of another citation or other special reason (as specified)

"O" document referring to an oral disclosure, use, exhibition or other means

"P" document published prior to the international filing date but later than the priority date claimed

"T" later document published after the international filing date or priority date and not in conflict with the application but cited to understand the principle or theory underlying the invention

"X" document of particular relevance; the claimed invention cannot be considered novel or cannot be considered to involve an inventive step when the document is taken alone

"Y" document of particular relevance; the claimed invention cannot be considered to involve an inventive step when the document is combined with one or more other such documents, such combination being obvious to a person skilled in the art.

"&" document member of the same patent family

Date of the actual completion of the international search

4 April 1996

Date of mailing of the international search report

17. 04. 96

Name and mailing address of the ISA

European Patent Office, P.B. 5818 Patentlaan 2
 NL - 2280 HV Rijswijk
 Tel. (+ 31-70) 340-2040, Tx. 31 651 epo nl,
 Fax: (+ 31-70) 340-3016

Authorized officer

Hocquet, A

INTERNATIONAL SEARCH REPORT

Intern. Application No
PCT/US 95/14824

C.(Continuation) DOCUMENTS CONSIDERED TO BE RELEVANT		
Category *	Citation of document, with indication, where appropriate, of the relevant passages	Relevant to claim No.
A Y	US,A,4 824 247 (TRUE) 25 April 1989 see column 5, line 8 - line 18 ---	8 41
Y A	US,A,4 225 405 (LAWSON) 30 September 1980 see column 8, line 54 - column 9, line 1 see column 15, line 15 - line 32 ---	31,45,46 29,43
Y	US,A,4 999 283 (ZAVOS PANAYIOTIS M ET AL) 12 March 1991 see abstract ---	30,44
A	GB,A,2 220 003 (WANG FU NAN) 28 December 1989 see page 9 ---	22,23
Y	EP,A,0 014 797 (EASTMAN KODAK CO) 3 September 1980 see page 5, line 30 - page 6, line 19; figures 1,3 ---	21,40
Y	US,A,5 230 866 (SHARTLE) 27 July 1993 see column 1, line 23 - line 26 see column 8, line 56 - column 9, line 25; figure 1 -----	16,38

INTERNATIONAL SEARCH REPORT

Information on patent family members

International Application No
PCT/US 95/14824

Patent document cited in search report	Publication date	Patent family member(s)	Publication date
WO-A-9322421	11-11-93	US-A- 5304487	19-04-94
		US-A- 5296375	22-03-94
		AU-B- 4222393	29-11-93
		AU-B- 4222593	29-11-93
		AU-B- 4222693	29-11-93
		AU-B- 4222793	29-11-93
		AU-B- 4223593	29-11-93
		CA-A- 2134474	11-11-93
		CA-A- 2134475	11-11-93
		CA-A- 2134476	11-11-93
		CA-A- 2134478	11-11-93
		EP-A- 0637996	15-02-95
		EP-A- 0637997	15-02-95
		EP-A- 0639223	22-02-95
		EP-A- 0637998	15-02-95
		EP-A- 0637999	15-02-95
		JP-T- 7506430	13-07-95
		JP-T- 7506431	13-07-95
		JP-T- 7506256	13-07-95
		JP-T- 7506257	13-07-95
JP-T- 7506258	13-07-95		
WO-A- 9322053	11-11-93		
WO-A- 9322054	11-11-93		
WO-A- 9322055	11-11-93		
WO-A- 9322058	11-11-93		
US-A- 5427946	27-06-95		
US-A- 5498392	12-03-96		
US-A- 5486335	23-01-96		
US-A-4824247	25-04-89	EP-A- 0404776	02-01-91
		WO-A- 9006724	28-06-90
US-A-4225405	30-09-80	US-A- 4276139	30-06-81
US-A-4999283	12-03-91	NONE	
GB-A-2220003	28-12-89	DE-A- 3904889	23-08-90
		FR-A, B 2638323	04-05-90
EP-A-0014797	03-09-80	US-A- 4233029	11-11-80

INTERNATIONAL SEARCH REPORT

Information on patent family members

International Application No

PCT/US 95/14824

Patent document cited in search report	Publication date	Patent family member(s)	Publication date
EP-A-0014797		AT-T- 4249	15-08-83
		AT-T- 1366	15-08-82
		CA-A- 1119831	16-03-82
		CA-A- 1129498	10-08-82
		CA-A- 1133059	05-10-82
		EP-A,B 0010456	30-04-80
		EP-A,B 0010457	30-04-80
		JP-C- 1196515	21-03-84
		JP-A- 55059326	02-05-80
		JP-B- 58026968	06-06-83
		JP-A- 55074462	05-06-80
		JP-C- 1248146	16-01-85
		JP-A- 55071942	30-05-80
	JP-B- 59021501	21-05-84	
US-A-5230866	27-07-93	AU-B- 1132392	28-01-93
		CA-A- 2061984	02-09-92
		JP-A- 5149958	15-06-93