



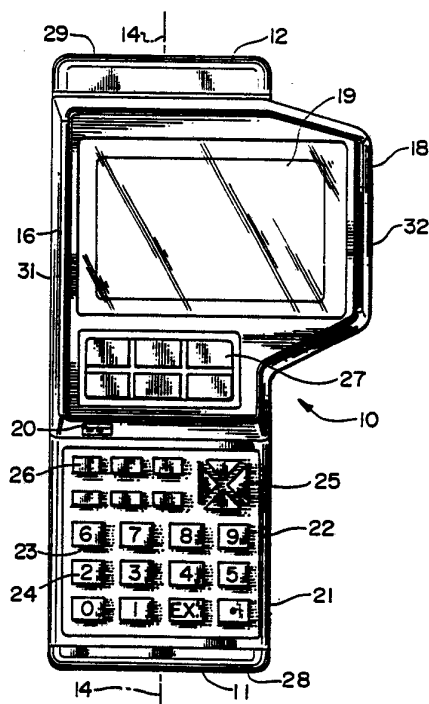
## INTERNATIONAL APPLICATION PUBLISHED UNDER THE PATENT COOPERATION TREATY (PCT)

<p>(51) International Patent Classification <sup>5</sup> : <b>G06F 15/02</b></p>	<p><b>A1</b></p>	<p>(11) International Publication Number: <b>WO 92/10803</b> (43) International Publication Date: <b>25 June 1992 (25.06.92)</b></p>
<p>(21) International Application Number: <b>PCT/US91/09421</b> (22) International Filing Date: <b>12 December 1991 (12.12.91)</b> (30) Priority data: <b>626,711</b> <b>12 December 1990 (12.12.90) US</b> (71) Applicant: <b>NORAND CORPORATION [US/US]; 550 Second Street, Southeast, Cedar Rapids, IA 52401 (US).</b> (72) Inventors: <b>KOENCK, Steven, E. ; 964 - 44th Street S.E., Cedar Rapids, IA 52403 (US). MILLER, Phillip ; 4114 Sunshine Street S.W., Cedar Rapids, IA 52404 (US). DANIELSON, Arvin, D. ; R.R. 2 Box 229A6, Solon, IA 52333 (US). MAHANY, Ronald, L. ; 1330 Sierra Drive N.E., Cedar Rapids, IA 52402 (US). DURBIN, Dennis, A. ; 140 Cambridge Drive N.E., Cedar Rapids, IA 52402 (US). CARGIN, Keith, K. ; 3219 Blue Ridge Drive N.E., Cedar Rapids, IA 52402 (US). HANSON, George, E. ; 1139 O Avenue N.W., Cedar Rapids, IA 52405 (US). SCHULTZ, Darald, R. ; 3861 Trailridge Road S.E., Cedar Rapids, IA 52403 (US). GEERS, Robert, G. ; 509 Green Valley Court, Cedar Rapids, IA 52403 (US). BOATWRIGHT, Darrell, L. ; 5731 Michael Drive N.E., Cedar Rapids, IA 52402 (US). GIBBS, William, T. ; 419 Green Valley Terrace S.E., Cedar Rapids, IA 52403 (US). KELLY, Stephen, J. ; 1405 McGowan Boulevard, Marion, IA 52302 (US).</b></p>		<p>(74) Agent: <b>REYNOLDS, Donald, P.; McAndrews, Held &amp; Malloy, Ltd., 500 West Madison Street, Chicago, IL 60661 (US).</b> (81) Designated States: <b>AT (European patent), AU, BE (European patent), CA, CH (European patent), DE (European patent), DK (European patent), ES (European patent), FR (European patent), GB (European patent), GR (European patent), IT (European patent), LU (European patent), MC (European patent), NL (European patent), SE (European patent).</b> <b>Published</b> <i>With international search report.</i> <i>Before the expiration of the time limit for amending the claims and to be republished in the event of the receipt of amendments.</i></p>

(54) Title: **HAND-HELD DATA CAPTURE SYSTEM WITH INTERCHANGEABLE MODULES**

(57) Abstract

A portable, hand-held data collection terminal unit is of modular structure including among other modules a display screen module, a keyboard module and a base module, each of which may be chosen from a plurality of modules available for assembly into the terminal unit. Consequently, a wide combination of terminal units may be assembled from a comparatively limited number of modular choices, such that the cost of assembly of a terminal unit with specific functions may be minimized. A particular selected module is a scanning module including a pivotable scanning head to permit a user to adjust the scanning head to a convenient position for operating the scanning module without sacrifice of visual access to a display screen of the display screen module. The display screen module may be selected from modules of standard width equal to the width of the terminal unit, of extended width extending when assembled to a selected keyboard module beyond either or both lateral edges of the terminal unit. The selected display screen module may include one of different sized screens, function keys and alphabetical keys.



**FOR THE PURPOSES OF INFORMATION ONLY**

Codes used to identify States party to the PCT on the front pages of pamphlets publishing international applications under the PCT.

AT	Austria	ES	Spain	MG	Madagascar
AU	Australia	FI	Finland	ML	Mali
BB	Barbados	FR	France	MN	Mongolia
BE	Belgium	GA	Gabon	MR	Mauritania
BF	Burkina Faso	GB	United Kingdom	MW	Malawi
BG	Bulgaria	GN	Guinea	NL	Netherlands
BJ	Benin	GR	Greece	NO	Norway
BR	Brazil	HU	Hungary	PL	Poland
CA	Canada	IT	Italy	RO	Romania
CF	Central African Republic	JP	Japan	SD	Sudan
CG	Congo	KP	Democratic People's Republic of Korea	SE	Sweden
CH	Switzerland	KR	Republic of Korea	SN	Senegal
CI	Côte d'Ivoire	LI	Liechtenstein	SU <sup>+</sup>	Soviet Union
CM	Cameroon	LK	Sri Lanka	TD	Chad
CS	Czechoslovakia	LU	Luxembourg	TG	Togo
DE*	Germany	MC	Monaco	US	United States of America
DK	Denmark				

+ Any designation of "SU" has effect in the Russian Federation. It is not yet known whether any such designation has effect in other States of the former Soviet Union.

## HAND-HELD DATA CAPTURE SYSTEM WITH INTERCHANGEABLE MODULES

BACKGROUND OF THE INVENTION

This invention relates generally to data collection systems, and more particularly to such systems wherein a hand-held unit may be operated to collect data, to selectively process, and to communicate collected data within such systems by various automated or manual operations. A typical automated process which may be included in such operations relates to collecting data by scanning bar code data with a laser scanning device. Subsequently, the collected data or information may be processed such as by becoming included in a data base. In another operation, it may be desired to communicate the information to another unit within a respective data collection system.

Various investigatory efforts in this area have shown that some functional applications of the data collection systems may require certain features on such hand-held units which may not at all be required in other functional applications. Going toward specialization of the units for specific tasks, the cost of operating the data collection systems tends to become more and more prohibitive as systems become configured to accommodate various specific applications. On the other hand, when data entry units are mass produced for general applications, efficiency in the application is jeopardized and compromise on various features results in less than the most efficient data handling procedures. It is consequently desirable to provide a data collection system in which hand-held units are equipped with features relating to particular needs without having a prohibitively high price tag.

- 2 -

SUMMARY OF THE INVENTION

The PCT application Serial Number 90/0382, filed June 7, 1990, assigned to and owned by the assignee of the present application, the descriptive matter of which is incorporated herein by reference in its entirety, refers to a modular hand-held unit and discloses a manner of attaching one functional module to another.

In accordance with the present invention, a selected one of a plurality of special purpose functional modules may be attached to another module of one of a selected second functional configurations to configure a plurality of different modules of different specific functional features. Thus, according to one aspect of the invention, with a reasonable number of functional modules a great number of differently configured modules may be provided.

A hand-held data collection terminal unit includes an elongate housing having a lower portion supportable in the hand of a user and an upper portion facing such user when the terminal is in a typical use position. The upper portion includes a keyboard and a display screen. In accordance with the invention, the hand-held terminal comprises a plurality of modules in which a base module extends longitudinally and includes inner and outer end caps of the terminal. The inner end cap is disposed on the end of the terminal which typically points toward a user when the terminal is in use, the outer end cap being disposed on opposite end of the terminal. A keyboard module is defined as an intermediate module disposed adjacent the base module and between the end caps. A display screen module is further disposed adjacent the intermediate module and adjacent the outer end cap of the base module.

SUBSTITUTE SHEET

- 3 -

According to a more particular aspect of the invention, the display screen module extends from the outer end cap of the base module longitudinally toward an end intermediate of the inner and outer end caps, such that a portion of the keyboard module remains exposed and features an array of manual input keys arranged in an area between the display screen module and the inner end cap.

According to another aspect of the invention, a data collection terminal unit includes a base module, a keyboard module disposed adjacent the base module and substantially of the same length and width as the base module. A display screen module is disposed adjacent the keyboard module and is disposed over at least one key arrangement of the keyboard unit. The display screen module is slidably arranged to be selectively slidable outward away from a user and from such at least one key arrangement to expose such keys for user access when the terminal unit is being placed into use.

According to yet another aspect of the invention, it is desired to protect the modular hand-held units from damage when the units are accidentally dropped. Resilient end caps and a layered resilient interface extending peripherally beyond substantial module portions impart shock absorbing qualities to the modular hand-held units.

According to a further aspect of the invention, a scanner module is attached as an end cap module to an outer end of a modular hand-held terminal unit. The scanner module includes a scanner head which is rotatable about a longitudinal axis of the modular hand-held terminal unit and selectively adjustable to one of a plurality of user positions in which the scanner may conveniently be used to collect data from, for example, bar code labels while a display screen on a display screen module remains in view of the user of the terminal unit.

SUBSTITUTE SHEET

- 4 -

In further describing the various features and advantages of the invention and of particular hand-held terminal units including and embodying features of the invention, the following spacial relations are being followed. Directional indications refer to a normal position of use of a hand-held data collection terminal. In such position the user would hold the terminal or terminal unit such that a display screen faces "up" into the direction of view of the user. Similarly, a keyboard would normally face up to be visible and manually accessible to a user. Correspondingly, the upper face of a data collection terminal unit is also referred to as a frontal side or face. The opposite side or portion of the unit is referred to as the rear or bottom portion of the unit and the direction in which the rear portion faces is the "lower, bottom or down" direction, or term of similar import. Also of interest are the descriptors at opposite ends of a longitudinal axis through a terminal unit. With the keyboard and display screen facing up, the longitudinal end of the terminal unit typically facing away from the user will be referred to and denoted as an "outer" end, while an opposite end of the unit directed toward the user when the unit is in a general position as described, is referred to as an "inner" end. These references should be kept in mind when reading the following detailed description.

Various other features and advantages of the data collection terminal in accordance with the invention will become apparent from the following detailed description, which may be best understood when read with reference to the appended drawings.

#### 35 BRIEF DESCRIPTION OF THE DRAWINGS

FIG. 1 shows a frontal view of a modular data collection terminal unit having a display screen

SUBSTITUTE SHEET

- 5 -

module which is enlarged to one side of a generally elongate shape of the terminal unit;

FIG. 2 is a side view of the data collection terminal unit shown in FIG. 1;

5 FIG. 3 is an outer end view of the data collection terminal unit shown in FIG. 1;

FIG. 4 is a frontal view of an alternate embodiment of a data collection terminal unit such as shown in FIG. 1, the alternate embodiment showing additional features including an RF communications capability, as indicated by an antenna extending laterally of the longitudinal body of the data collection terminal unit;

15 FIG. 5 is a side view of the data collection terminal unit shown in FIG. 4;

FIG. 6 is a frontal view of yet another embodiment of a data collection terminal unit in accordance with the invention, the terminal unit showing a display screen which extends laterally beyond the basic longitudinal shape of the terminal unit;

FIG. 7 is a frontal view of a data collection terminal unit similar to the terminal unit shown in FIG. 1, except that a display screen module is shown which is confined to the generally longitudinal shape of the data collection terminal unit;

FIG. 8 is a frontal view of another embodiment of a data collection terminal unit in which the display screen module of the the terminal unit in FIG. 7 has been replaced by an elongate display screen module in which function or control keys have been eliminated to afford room for added display area of the display screen;

FIG. 9 is a frontal view of a data collection terminal unit showing a first keyboard array adjacent an inner end of the terminal unit and a display screen module adjacent an outer end of the terminal unit;

- 6 -

FIG. 10 is a frontal view of the data collection terminal unit shown in FIG. 9, in which the display screen module has been extended outwardly away from the user to uncover a second keyboard array which is in the non-extended position of the display screen module disposed beneath such module;

FIG. 11 is a schematic representation of various modules and elements of the terminal unit showing a basic manner of assembling selected ones of the various modules to each other;

FIG. 12 is a somewhat simplified view of a data collection terminal unit in which a scanner module is mounted to an outer end of the terminal unit, the scanner module including a scanner head which is mounted to rotate about a longitudinal axis of the data collection terminal unit;

FIG. 13 is a side view of a scanner module, such as in FIG. 12, shown with the scanner head in a typical, laterally disposed rest position;

FIG. 14 is a side view of an alternate embodiment of a scanner unit, the scanner unit being fixedly attached to an outer end of the terminal unit and having a viewing direction at an angle with respect to the longitudinal axis of the data collection terminal;

FIG. 15 is an end view of a display screen module of the type shown in FIG. 6, the end view showing an attachment surface of the display screen module;

FIG. 16 is a frontal view of the display screen module of FIG. 15 in combination with a handle and power supply module;

FIG. 17 is a side view of the display screen and handle and power supply modules of FIG. 16;

FIG. 18 is a frontal view of a data collection terminal unit showing an alternate embodiment of a keyboard module in combination with a display screen;



- 7 -

FIG. 19 is a side view of the data collection terminal unit shown in FIG. 18;

5 FIG. 20 is yet another embodiment of the data collection terminal unit shown in FIGS. 18 and 19, showing a screen display confined to the width of the keyboard module of the data collection terminal unit; and

10 FIG. 21 is an alternate frontal view of the data collection terminal unit shown in FIG. 20, showing a pivotally mounted screen display in an open position, revealing a second screen display and a second keyboard.

#### DETAILED DESCRIPTION OF THE INVENTION

15 Referring to the various illustrations in sequence, a data collection terminal unit which is designated generally in FIG. 1 by the numeral 10, is shown as undergoing various changes and modifications as selected different modules may be substituted for other modules and functions and capabilities of the data collection terminal unit 10 are correspondingly altered.

20 In reference to FIG. 1, there is shown a frontal view of the data collection terminal unit 10. In furtherance of advantages and objects of the invention, the data collection terminal unit 10 is a modular unit in that a plurality of modules become attached to each other to form the terminal unit 10. A general shape of the terminal unit 10 is an elongate rectangular shape as can be ascertained from the drawing. The terminal unit has an inner end 11 which typically is closest to a person using the terminal unit 10 when the terminal unit is in a typical hand-held operating position in which a user exposes a keyboard and a display screen toward the line of sight. Opposite the inner end 11 an outer end 12 of the data collection terminal unit is directed away from a user when the terminal

SUBSTITUTE SHEET

- 8 -

unit 10 is hand-held in a typical use position. The general shape of the terminal unit is that of an elongated rectangle, such that a hypothetical longitudinal centerline or central axis indicated at 14 can be envisioned to extend in the longitudinal inward-outward direction of the terminal unit 10. The frontal view shows a display screen module 16 which is enlarged to one side of the terminal unit 10. A lateral extension 18 of the display screen module is in the preferred embodiment shown to extend toward the right hand side of the central axis 14 beyond the generally elongate rectangular shape of the terminal unit 10. The direction may be one of convenience to a user. The lateral extension, whether toward the left or right of the longitudinal axis 14 extends the line width of the viewing area of a display screen 19 of the module 16. Such extension 18 is desired to permit an alphanumeric instruction to be contained within a single character line of display, for example. The display screen module 16 further may include a main power switch 20, in that in various configurations of the terminal unit 10 a display screen module or its equivalent would be included. Below the display screen module 16, and inwardly disposed, lies a keyboard module 21. The keyboard module 21 includes a particular keyboard 22 which may typically include an arrangement 23 of numerical keys 24. The numerical keys 24 are desirably supplemented by a cluster of cursor keys 25 and by selected function keys 26. The keyboard module 16 may also include a cluster of further function switches 27. It should be understood that the modules 16 and 24 are mechanically attached to and part of the terminal unit 10 and are further electrically interconnected, such as may conveniently be achieved by typical flat cables and respective connectors, not shown. It is therefore convenient to provide cursor movement

SUBSTITUTE SHEET

- 9 -

keys, such as the keys 25 as part of the keyboard, in that it is typically intended for the terminal unit 10 to feature a display screen module.

Further in accordance with the invention, the terminal unit 10, the unit being typically hand-held, is subject to accidentally being dropped. To protect the terminal unit 10 from damages when dropped an established height, resilient end caps 28 and 29 cover the inner end outer ends 11 and 12, respectively. In addition, it has been found desirable to protect lateral ends of the display screen module 16 similarly with resilient strips 31 and 32.

FIG. 2 is a side view of the data collection terminal unit 10. The side view of the terminal unit 10 further illustrates the modular construction of the terminal unit 10. A base module 34 desirably includes a central handgrip portion 35 and may further include a resilient strap 36, such that a user may insert the hand between the handgrip portion 35 and the resilient strap. A battery compartment 38 is shown at the lower, inner end of the base module 34. In that the terminal unit is a hand-held unit, an internally disposed electrical power source such as a battery module 39 is virtually required for desired operation of the terminal unit. In one configuration, the battery compartment comprises an opening into which the battery module 39 is inserted. The external shape of the battery module conforms to the shape of the base module to form part of it. The battery module 39 is desirably replaceable in a field exchange operation and may be removed by sliding the module 39 in the direction of the arrow 40. To secure the battery module within the base module 34, a locking mechanism which may be opened and closed by a coin, for example, is found to facilitate such replacement. A peripheral resilient strip or spacer

- 10 -

41 preferably overlies the base module 34 and functions as a shock absorber when the terminal unit 10 is accidentally dropped on its side surfaces. Adjacent the outer end of the handgrip portion 35 is disposed a function key 43. The function key 43 may be a data entry initiation key or a scanner operation control key when the terminal unit is equipped with a scanner module. It should be noted, that the function key 43 is disposed for persons holding the terminal unit in their right hand, such that the index finger of the user's right hand may be used to operate the key 43. The base unit may be furnished with a similar key 43, not shown, on the opposite side of the base module 34 to allow a person holding the unit with the left hand to operate such key. The respective keys would be electrically coupled to function in parallel, such that the desired function can be initiated from either side of the terminal unit 10. Disposed between the resilient end caps 28 and 29 and adjacent the resilient spacer 41 is the keyboard module 21. The keyboard module 21 functions consequently as a mounting base for the display screen module 16. A recess or step 46 in the upward facing surface 47 of the keyboard module 21 seats the display screen module 16. The display screen module 16 is preferably attached by typical screw type fasteners through the keyboard module 21. The keyboard module 21 in turn may be fastened in a similar manner from the bottom surface of the base module 34. In accordance with the invention, the keyboard module 21 further comprises a recess 48 for receiving one of a number of differently configured versions of the keyboard 22. The selected keyboard 22 is also attached through the body of the keyboard module 21 with respective fasteners, such as screws, for example.

SUBSTITUTE SHEET

- 11 -

FIG. 3 is an outer end view of the data collection terminal unit 10. The need for the referred to resilient protective strip 3220 may be realized in viewing lateral extending portion 18 of the display screen module 16.

FIG. 4 is a frontal view of a data collection terminal unit 50 which is an alternate embodiment of the terminal unit 10. In particular, the terminal unit 50 comprises a display screen module 51 including an arrangement 52 of alphabetical keys 53. The display screen module 51 further includes an arrangement of function keys 54 disposed vertically along a display screen 55. To accommodate the key arrangement 52, the display screen module 51 is also laterally extended as the display screen module 16. Consequently, lateral resilient strips 56 and 57 are preferred to increase the drop resistance of the terminal unit 50 as previously discussed with respect to the terminal unit 10. Because of the area occupied by the keys 52 and the function keys 54, the display screen is does not extend beyond the lateral sides of the generally elongate shape other than the extended display screen display module 51. The terminal unit 50 further shows an outwardly extending antenna 58 as part of and evidencing a radio frequency communication system 59 being part of the terminal unit 50. As described with respect to the terminal unit 10, the terminal unit 50 also includes the resilient end caps 28 and 29. A keyboard 61 may be functionally different than the previously described keyboard 22, though it may be fitted into the aforementioned recess 48 of the keyboard module 21. In particular, the keyboard 61 shows a main power switch 62, rather than having such switch associated with the display screen module 51. As can be ascertained from the terminal unit 50, modules such as the keyboard module 21 may be interchangeably used with one of a number of

SUBSTITUTE SHEET

- 12 -

display screen modules, such as the modules 16 and 51.

5 FIG. 5 is a side view of the data collection terminal unit 50. A base module 63 may in outer dimensions be the same as the base module 34 described with respect to FIG. 2. One difference may be noted in the configuration of a battery module 64 with respect to the configuration of the battery module 39. The battery module 64 shows less  
10 external surface and is inserted for a substantial portion into the base module 63. The central handgrip portion 35 of the base module is in essence identical in both base modules. Another notable difference relates to a laterally disposed outer  
15 function key 66 which preferably may include more than one function, such as an enter function and scan function. The function key may be operated to enter data and to operate a scanning module when such a scanning module is provided. To operate the  
20 enter function, an inner end 67 of the function key 66 is depressed. To operate the scanning function an outer end 68 may be depressed. The respective, inner and outer locations are assigned because of a preferred addition of a scanner module  
25 in lieu of the outer end cap 29. As described with respect to the function key 48, the function key may be provided on either or both sides of the respective base modules. When the function keys are not provided, they may be deleted and replaced by a  
30 plug (not shown) which would be installed in lieu of the function switch. Also to be observed is the one for one replacement of the display screen module 51 for the previously described display screen module 16 into the keyboard module 21.

35 FIG. 6 is a frontal view of yet another terminal unit 70, having a uniquely wide screen 71 disposed in a display screen module 72. The display screen module 72 is mounted in the manner described

with respect to the display screen module 16 to the keyboard module 21. The display screen module 72 extends to both sides with respect to the central axis 14 of the terminal unit 70 beyond the width of the base module 34 or 66 and the keyboard module 21. The size of the display screen 71 permits only a limited number of function keys 73 which are preferably disposed adjacent the outer edge of the of the keyboard 22. The display screen module 72 may also include a power switch 74 when such a function is not part of the keyboard module 21 and its respective keyboard 22. It should be realized, however, that without diminishing the width of the display screen 71, the number of display lines thereon may be diminished to include on another display screen module an alphabetical keyboard.

FIGS. 7 and 8 show terminal units 75 and 76, respectively. Both terminal units show display screen modules 77 and 78, respectively, in which respective display screens 79 and 81 are contained within the lateral bounds of the keyboard module 21. The display screen module 77 includes function keys 82, arranged in an earlier referred to arrangement. In contrast, the display screen module 78 does not include the function keys 82 but is instead in the direction between the inner and outer ends 11 and 12 of the terminal unit 76, hence in the vertical direction of the display screen enlarged. Thus, FIGS. 7 and 8 show further embodiments of the terminal unit that can be provided with only minor modifications in the assembly of the respective units.

FIG. 9 is a frontal view of a data collection terminal unit 85 which features a variation of the described keyboard and display screen modules. The terminal unit 85 includes a display screen module 86 and a keyboard module 87. As in the previously described terminal units, the keyboard module 87

- 14 -

extends substantially between the inner and outer ends 11 and 12 of the terminal unit 85. A first keyboard 89 is mounted into an innermost end of the keyboard module 87. However, the display screen module 86 is outwardly slidably mounted to slide from an innermost position as shown in FIG. 9 to an outermost position shown in FIG. 10. Sliding motion is supported by rails 91 and 92 disposed along opposite sides of the terminal unit 85. In the outermost position of the display screen module 86, a second keyboard 94 is uncovered, in that the second keyboard is located directly adjacent the innermost position of the display screen module 86. The second keyboard 94 may be received by the keyboard module 87 in a recess similar to the keyboard 88. The first and second keyboards may be of different heights between inner and outer ends, or the keyboards may be configured to be of equal height. In such a configuration the keyboard module may be provided with proper recesses which are of the same size. In the described embodiment, the first keyboard has a greater vertical height than the second keyboard, and respectively differently sized cavities for receiving the first and second keyboards 88 and 94 are provided. The differences in size may prevent an inadvertent switching of the respective keyboards 88 and 94 during assembly of the terminal unit 85.

FIG. 11 is a schematic representation of various modules and elements of the described terminal units showing a basic manner of assembling selected ones of the various modules to each other. In particular, the base module 34 is shown adjacent the battery module 39. The two modules may be combined initially or at a later time in that it is contemplated to facilitate the replacement of the battery module 39 without further disassembly of the respective terminal unit. The resilient spacer 41



- 15 -

is preferably a rubber compound which may be of a hardness to absorb a typical fall of the unit. The spacer 41 is assembled between the base module 34 and the keyboard module 21 or a similar keyboard module. A selected keyboard and display screen module is assembled to the selected keyboard module prior to its assembly to the base module 34 or its selected equivalent base module. The outer end cap 29 may be removed or initially deleted from the assembly and a CCD type scanner module 96 or a laser scanner type module 97 may be attached to the outer end 12 of the terminal unit. FIG. 11 shows such scanner modules 96 and 97 in phantom lines as alternative additions to the respective terminal unit. In maintaining the shock absorbing characteristics of the assembled terminal unit, such as terminal unit 10, if a scanner module, such as shown at 96 or 97, is included at the outer end 12 of the terminal unit 10, the scanner modules are desirably furnished with an resilient end cap 98 or 99, respectively.

FIG. 12 is a simplified view onto an outer end 12 of a data collection terminal unit 101 in which a scanner module 102 is mounted to the outer end. The scanner module 102 is shown in a rest mode in which the scanner is less likely to be operated. The scanner module 102 has a scanning head 103 including an optical opening 104 through which scanned data are acquired. In the typically inactive position of the scanner module 102, any scanning would be done with the optical opening pointing toward one side of the terminal unit 101. In such position a user is not able to direct the scanning operation straight ahead while at the same time viewing a display screen 105 on the upper face of the terminal unit 101. To overcome the limitation, the scanning head 103 is rotatably or pivotably attached to the scanner module 102 to

SUBSTITUTE SHEET

- 16 -

5 pivot about the longitudinal central axis 14 through the terminal unit 101. Preferably, the scanning head 103 may be moved to a number of intermediate positions between the lateral positions in which the optical opening 104 points to either side of the terminal unit 101. A particular number of positions, such as fifteen degrees increments may be preferred. Thus, between opposite extreme lateral positions, the scanning head may be pivoted through an angle of at least 180 degrees. An alternate, angularly disposed orientation of the scanning head 103 is shown in phantom lines as an example of the pivotable movement of the scanning head 103. The pivotable movement in either direction from the alternate position shown is indicated by an arrow 106.

10 FIG. 13 shows a side view of the data collection terminal unit 101. The scanner module 102 may be attached to the outer end of the data terminal unit by removing the end cap 29 and attaching in its place a mounting base 108 of the scanner module 102. Internal data communications connections which are not shown, would include a typical data bus coupled to the microprocessor control of the data collection terminal unit 101 to permit the scanner module 102 to be operated as an integral element of the data collection terminal unit 101. The position in which the scanning head 103 is shown, is a typical rest position for the scanner module, in which the scanner would be least likely to be operated.

20 25 30 35 FIG. 14 is a side view of an alternate embodiment of a scanner module 110. Contrary to the scanner module 102, the scanner module 110 is not pivotally attached by the base 108. Instead, a fixed scanner head 111 is shown, in which the direction of scanning may preferably be at an angle in a range about 45 degrees from the longitudinal axis of the

SUBSTITUTE SHEET

- 17 -

data collection terminal unit 101 is preferred. To increase the shock absorbency of the scanner module outer surface, a window portion 112 of the scanner head 111 is protected at its outer rim with preferred rubber cushioning, a shock damper having been found supportive of preventing breakage of the data collection terminal unit 101 and particularly of the scanner head 101. The scanner module 110 further comprises an inward extension 113 adjacent a lower surface 114 of the data collection terminal unit 101. A threaded fastener 115 may be used to fasten the extension 113 to the underside 114 of the data collection terminal unit 101. It should be recognized that other modifications and changes may be made with respect to the laser scanner heads attached to the outer end of the data collection terminal unit in furtherance of the objects of the invention.

FIG. 15 is an end view of a display screen module 120 of the type of display screen module 72 shown in FIG. 6. The end view shows an upwards directed display screen surface 121, also showing in profile a plurality of keys 123 which may be a combination of alphanumeric keys and function keys for implementing functions of the display screen module 120. Also shown as an edge view or in profile is a sculptured lower surface 126 of the display screen module 120. Preferably, a central portion 127 of the lower surface 126 is a flat surface portion of substantially the same width as an interface surface of the respective keyboard module to which the display screen module typically mounts.

FIG. 16 shows a frontal view of the display screen module 120. An outer end 128 of the display screen module 120 may feature an antenna, such as the antenna 58 of the transceiver unit 59 shown in FIG. 4, for example. Adjacent an inward facing

- 18 -

edge 131 of the display screen module 120 may be located an array of the plurality of keys 123 which may be alphanumeric, of numeric and a combination of function keys arranged in one or more rows as  
5 illustrated. Outwards adjacent the keys 123 there is a display screen 134 capable of displaying multiple rows and columns of graphic symbols or of alphanumeric information or data. A handgrip module or handle module 135 is shown as extending toward  
10 the left hand side of the display module 120 with respect to the inner edge 131 as a base line. The handle module 135 includes a grip portion 136 which also functions as a battery compartment. A strap 137 may overlies the grip portion 136, such  
15 that a user may slip a hand between the grip portion 136 and the strap 137. The strap 137 preferably includes two strap halves which may be attached to each other at various lengthwise displaced distances by typical hook and loop  
20 fastening materials for adjustment.

FIG. 17 is a side view of the display screen module 120 and handle module 135. A battery module 138 is disposed within the hand grip portion 135. An upper lip 140 of the grip  
25 portion 136 overlies the upper surface 121 of the display screen module 120. The upper lip 140 preferably engages a retainer ridge 141 disposed on the upper surface. An identical retainer ridge 141 may be disposed on the other side of the display  
30 screen module 120, such that the handle module 135 becomes reversible and may be attached to one side as shown, or to the other side of the display screen module, depending on the preference of the user. The handle module 135 has an elongate support  
35 portion 143 which extends along the lower surface 126 of the display screen module 120 and is preferably mounted to the central portion 127 of the lower surface 126. Electrical contact between the

- 19 -

handle module 135 and the display screen module 120 may preferably be made across an interface 144 at the central portion 127. A plurality of spaced electrical contacts 145, disposed substantially in the plane of the interface 144 establish electrical and communication contact between the handle module 135 and the respective display screen module 120. A recess 146 in the support portion 143 is part of the grip portion. Adjacent the recess 146, oppositely spaced, parallel guide tracks 147 provide for the handle module to be slidably inserted into and to become electrically coupled to an external power supply and battery charger unit (not shown). A plurality of electrical power and communication contacts 148 establish contact for electrical power and signal communication with such a power supply and battery charger unit. A transceiver module 149 may be disposed within the support portion 143 for communication between an external data device (not shown) and the display screen module 120, such that data from the external data device may be displayed to be accessible to a user of the combination of the display screen 120 and the handle module 135. The described combination consequently refers to an alternate use of the display screen module 120 in addition to the previously described use of such a display screen module in combination with a keyboard assembly, as, for example, with respect to the data collection terminal unit 70.

FIG. 18 is a frontal view of a data collection terminal unit 150 showing a keyboard module 151. The keyboard module 151 differs from a previously described keyboard module 87, for example, in that a display screen module 153 is pivotally attached to an outer end 154 of the keyboard module 151. The display screen module 153 accordingly necessarily requires a hinged attachment to a respective module,

SUBSTITUTE SHEET

- 20 -

such as the keyboard module 151. A hinge 156 includes display screen hinge members 157 and complementary hinge discs 158 of the keyboard module 150. A hinged attachment of the display screen module 153 to the keyboard module 151 shows an interleaved disposition of the disc-like, spaced hinge members 157 with the complementary hinge discs 158 of the keyboard module 151. The respective hinge members 157 and hinge discs 158 may include laterally disposed electrical contact members disposed on respectively facing surfaces thereof to couple electrical power and data communication from the keyboard module 151 to the display screen module 153. It is contemplated that the display screen module be pivoted from a first, closed position to a preferred open position selected from a range of possible positions, such as may be suitable and most convenient to a user. The keyboard module 151 may include a keyboard, such as the keyboard 88 described with respect to FIG. 10, for example. Keyboards which differ in their configuration from the configuration of the keyboard 88 but which are identical in electrical contacts and interface arrangements and in physical dimensions may be inserted in lieu of the keyboard 88. The display screen module 153 has a first display screen 161 disposed in an outer surface 162 thereof. The size of the display screen 161 is one of choice, but may preferably be chosen to accommodate a typical numerical data display, hence be of a size substantially less than one which might occupy a major portion of the outer surface 162 of the display screen module 153. Similarly to the embodiment described in reference to FIG. 4, the data collection terminal unit 150 may include a transceiver unit 59 as indicated by the antenna 58.

SUBSTITUTE SHEET

- 21 -

FIG. 19 is a side view of the data collection terminal unit 150. The terminal unit 150 includes a typical base module 165, similar to the base module 34 described with respect to FIG. 2 hereof.

5 The base module 165 is shown as including the handgrip portion 35 and the strap 36. Resilient, shock absorbing end caps 28 and 29 are desirably attached to the respective inner and outer ends 11 and 12 of the data collection terminal unit 150.

10 The display screen module 153 is shown in the first or closed position. The closed position is considered also the normal position in which the module 153 is disposed essentially against an outward disposed portion 167 of the keyboard module 151.

15 The display screen module 153 may however be pivoted into an upward or open position within a range of open positions, substantially as indicated by the alternate position of the display screen module 153 shown in phantom lines. As the

20 display screen module is pivoted to such upward position, a second display screen 19 disposed on the normally hidden underside 168 becomes visually accessible to a user. The display screen 19 is preferably recessed within an outer rim 169 of the

25 display screen module 153. In the downward pivoted position the display screen module 153 may cover an auxiliary or second keyboard 171. The additional keys 172 of the second keyboard 171 may add alphabetical keys and function keys to be accessed

30 by the user. In achieving the advantages sought by the present invention, both the first and the second keyboards 88 and 121 are removably mounted to the keyboard module 151 and may be exchanged for keyboards of identical lateral extent and having

35 different key arrangements on a front surface thereof. Thus, the keyboard 171 may be exchanged for another keyboard having keys for different data or control input to the respective data collection

SUBSTITUTE SHEET

- 22 -

terminal unit. Also, depending on the type of operation contemplated by the user of the data collection terminal unit 150, the user may employ the unit with the display screen module 153 in a downward position with the first keyboard 88 being the sole keyboard available for data entry and the first display screen 161 providing a corresponding visual indication of data made available to the user. In the alternative, the user may pivot the display screen module into an upward pivoted position, giving access to a second display screen 19 which is in comparison to the first display screen 161 larger in active area and capable of displaying a greater amount of information. The second keyboard 171 to which the user has gained access simultaneously with the access to the relatively larger display screen 19 desirably provides the capability of alphabetical data information. Electrical provisions in the hinge 156 may include position controlled contacts 174 which selectively activate the display screen 161 or the display screen 19 in response to an opening or closing of the display screen module 153 in the manner described. The display screen module 153 differs from the previously described display screen modules in that the display screen module 153 is hingedly attached to the respective keyboard module 151. In this manner, the display screen module 153 is a sub-module of the keyboard module 151. However, it is also contemplated that the display screen module 153 may be interchanged with other display screen modules having similar spaced hinge members 157 to be compatible with the hinge discs 158 of the keyboard module 151.

FIG. 20 is a frontal view of such alternate embodiment, showing a data collection terminal unit 175 which includes the described keyboard module 151. To the outer end 154 of the keyboard



- 23 -

module 151 a display screen module 176 has been pivotally attached in lieu of the already described display screen module 153. In clear contrast to the display screen module 153, the display screen module 176 is laterally confined substantially to the overall width of the keyboard module 151 of the data collection terminal unit 175. The attachment of the display screen module 176 to the keyboard module 151 is identical to the attachment of the display screen module 153 at the hinge 156 as previously described. In the closed position of the display screen module 176, the first or outer display screen 161 may preferably be identical to the first display screen of the display screen module 153 in that in the closed position of the display screen module 176 only the first keyboard, preferably the numerical keyboard 88 is accessible to the user, and the size and display area of the display screen 161 is adapted to a desired display format commensurate with data input from the first keyboard, such as the keyboard 88.

FIG. 21 is an alternate frontal view of the data collection terminal unit 175, showing the display screen module 176 in an upward pivoted position. The pivoted position reveals the second keyboard 171 of the keyboard module 151 and makes a second display screen 178 of the display screen module 176 accessible to the user. Consequently, as shown in FIG 21, the user may now manually enter data by manipulating any of the keys which make up the keyboards 88 and 171. The combination of the substantially numerical keyboard 88 and the substantially alphabetical keyboard 171 results in a complete alphanumeric keyboard. As described, pivoting the display screen module 176 from a closed position, as shown in FIG. 20, to the open position of FIG. 21 would be effective in one embodiment to

- 24 -

switch displayed information from the first display screen 161 to the second display screen 178.

5 Various changes and modifications in the structure of the described embodiment are possible without departing from the spirit and scope of the invention as set forth in the claims.

## WHAT IS CLAIMED IS:

1. A hand-held data collection terminal unit comprising:

5 a display screen module selected as a preferred one of a plurality of display screen modules available for assembly into said terminal unit; and  
a keyboard module selected as a preferred one of a plurality of keyboard modules available for assembly into said terminal unit, the selected  
10 display screen module being attached to one end of the selected keyboard module.

2. The terminal unit according to claim 1, wherein the display screen module is selected from a plurality of display screen modules at least one of  
15 which is as wide as the width of the terminal unit and at least one other of the display screen modules is wider than the width of the terminal unit and extends upon being attached to the selected keyboard module on at least one side beyond the lateral  
20 confines of said terminal unit.

3. The terminal unit according to claim 1, wherein the terminal unit comprises mounted externally of the terminal unit, said shock absorbing means comprising resilient end caps  
25 mounted to opposite ends of the terminal unit.

4. The terminal unit according to claim 1, further comprising a base module selected as a preferred one of a plurality of base modules for assembly with the selected keyboard module including  
30 the selected display screen module.

5. The terminal unit according to claim 1, wherein the terminal unit further comprises a radio frequency communications module.

- 26 -

6. The terminal unit according to claim 1, wherein the terminal unit further comprises a scanning module.

5 7. The terminal unit according to claim 6, wherein the scanning module is attached to an outer end of the terminal unit.

10 8. The terminal unit according to claim 7, wherein the scanning module includes a pivotable scanning head, the head being pivotable through at least 180 degrees between two opposite end positions.

15 9. The terminal unit according to claim 8, wherein the scanning head may be indexed to a plurality of discrete, predetermined positions intermediate the two opposite end positions.

10. The terminal unit according to claim 1, wherein the keyboard module comprises a keyboard selected from a plurality of keyboards available for assembly to the keyboard module.

20 11. The terminal unit according to claim 10, wherein the terminal unit comprises externally disposed shock absorbing means for protecting the terminal unit from sudden impact.

25 12. The terminal unit according to claim 10, wherein the selected display screen module comprises a display screen, function keys and an arrangement of alphabetical keys, and wherein the selected keyboard module comprises a keyboard including a power switch.

30 13. The terminal unit according to claim 12, wherein the keyboard further comprises an

- 27 -

arrangement of numerical keys and a cluster of cursor keys.

14. The terminal unit according to claim 10, further comprising a base module selected from a plurality of base modules available for assembly  
5 into the terminal unit.

15. The terminal unit according to claim 14, wherein the base module comprises a battery module.

16. The terminal unit according to claim 14,  
10 wherein the selected base module and the selected keyboard module are assembled with an interposed resilient shock absorbing means for minimizing impact forces directed against the terminal unit during a fall of the terminal unit.

17. The terminal unit according to claim 10,  
15 wherein the terminal unit further comprises a scanning module.

18. The terminal unit according to claim 17,  
20 wherein the scanning module is attached to an outer end of the terminal unit.

19. The terminal unit according to claim 18, wherein the scanning module includes a pivotable scanning head for pivoting through an angle of at least 180 degrees.

20. The terminal unit according to claim 19,  
25 wherein the terminal unit includes at least one laterally disposed function switch operatable to activate and deactivate the scanning operation of the scanning module.

21. The terminal unit according to claim 1,  
30 wherein the display screen module is slidably

- 28 -

mounted to the keyboard module to slidably move between a retracted and an extended position, wherein the keyboard module includes a first key arrangement accessible with the display screen module being in either of the positions and a second key arrangement disposed below and covered by the display screen module when the display screen module is in the retracted position and accessible to a user when the display screen module is in the extended position.

22. The terminal unit according to claim 1, wherein the display screen module is pivotally attached to an outer end of the keyboard module for pivotal movement between a first closed position and a range of second, open positions, the keyboard module including first and second keyboards, the first keyboard being accessible when the display screen module is pivoted to a first, closed position, the display screen module having first and second display screens, the first display screen being outward facing and visually accessible when the display screen module is in the closed position, the second display screen being visually accessible when the display screen module is pivoted into the open position.

23. The terminal unit according to claim 22, wherein the display screen module, upon being in the closed position is disposed against the second keyboard and covers the second keyboard from access.

24. The terminal unit according to claim 22, wherein the first and second keyboards are selectively replaceable by a keyboard from a group of keyboards of different key arrangements and capable of communicating different functions to the terminal unit.

- 29 -

25. A hand-held data collection terminal system comprising:

at least one set of interchangeable display screen modules, a plurality of interchangeable keyboard modules, at least one base module and at least one handgrip module;

each of the keyboard module being selectively attachable to the base module, and any selected one of the display screen modules of a preselected set being attachable to a selected one of the plurality of interchangeable keyboard modules; and

selected ones of the display screen modules being attachable to the handgrip module, whereby a selected display screen module is removable from a keyboard module and attachable to said handgrip module.

26. The data collection terminal system according to claim 25, wherein the handgrip module comprises a handgrip portion, a battery compartment, a battery module disposed within the battery compartment, interface means for electrically and communicatively coupling the handgrip module to the selected display screen module, and means for electrically and communicatively coupling the handgrip module to a power supply module.

SUBSTITUTE SHEET

FIG. 1

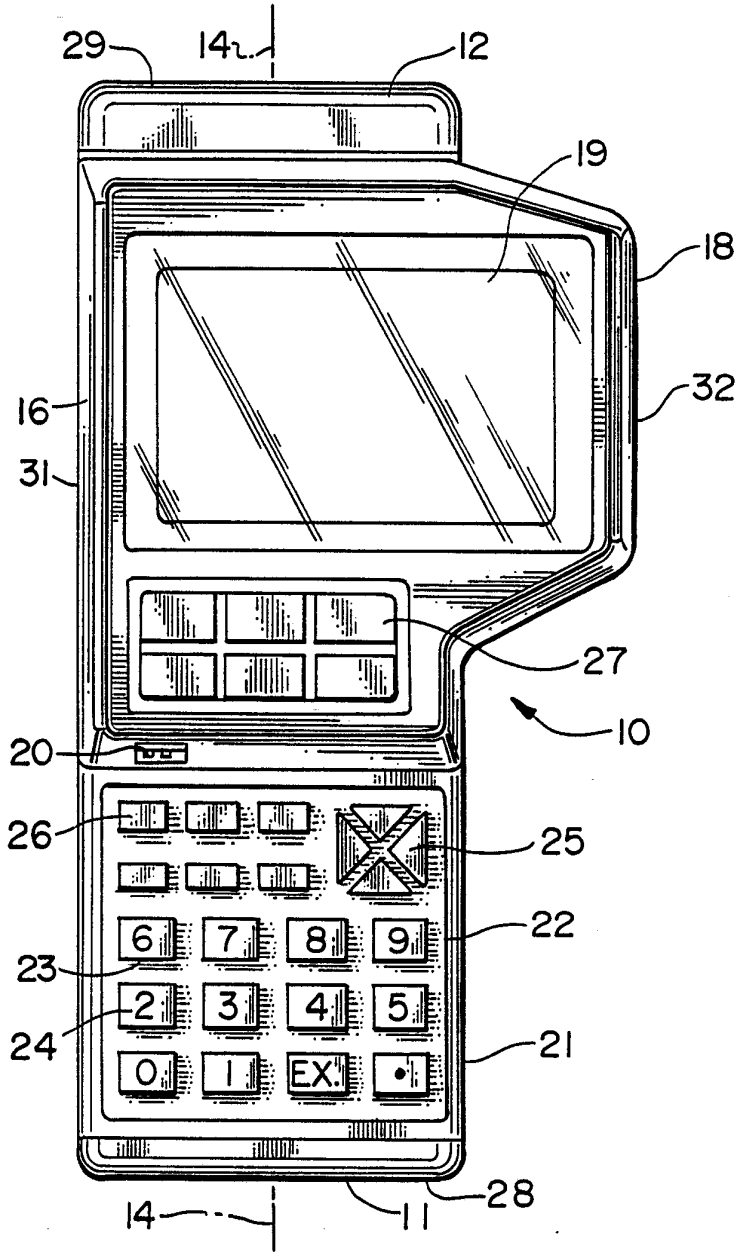


FIG. 2

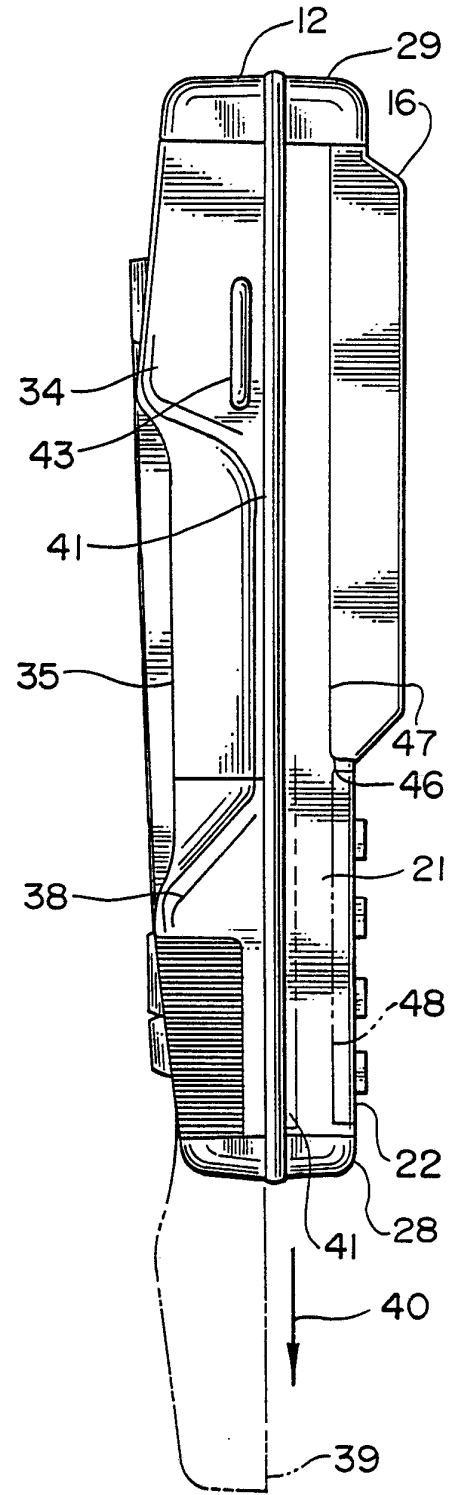
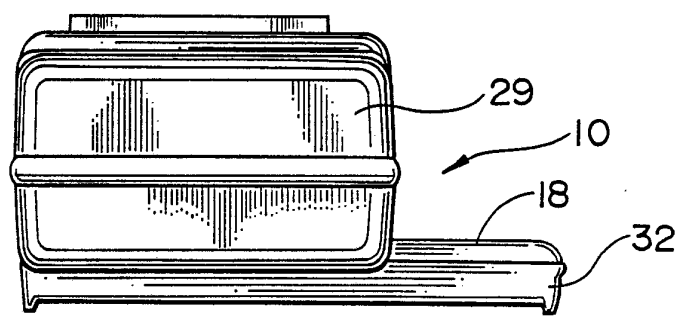
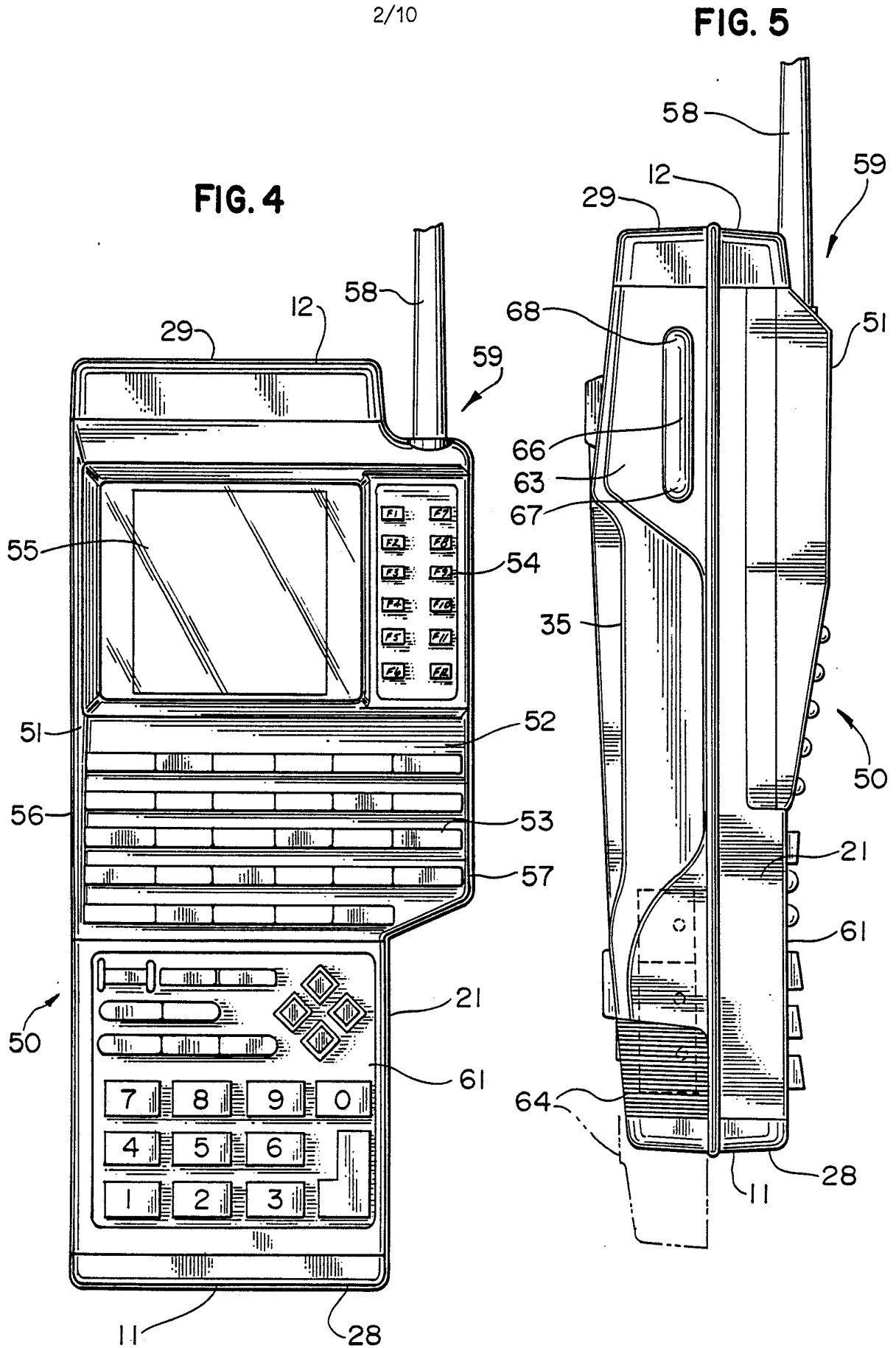


FIG. 3







3/10

FIG. 6

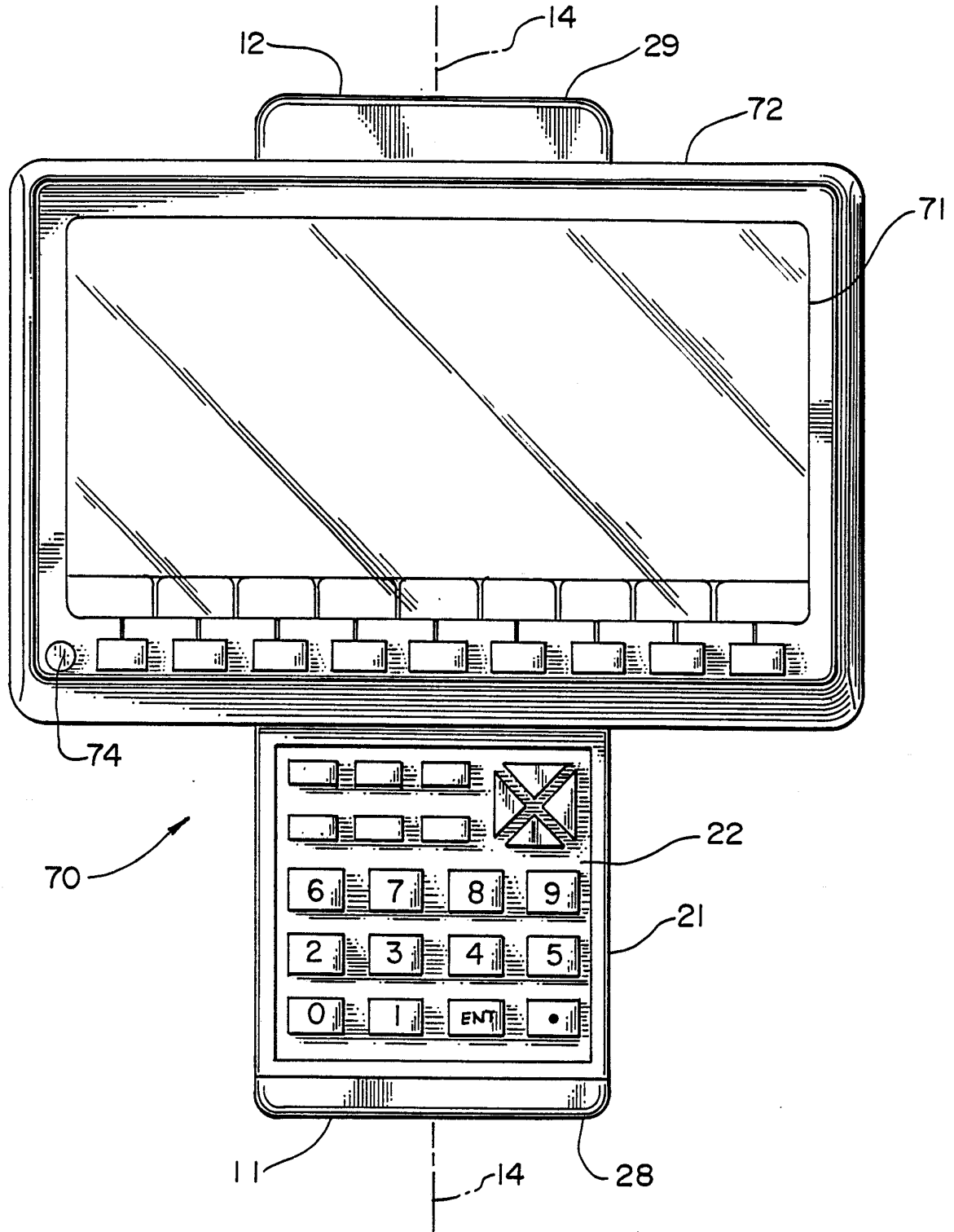


FIG. 7

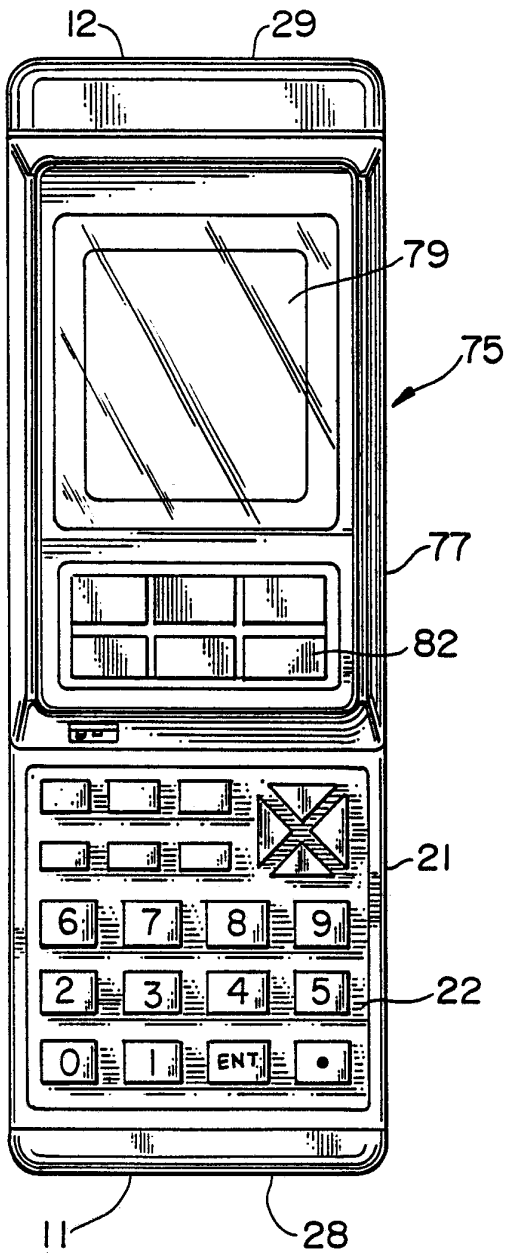


FIG. 8

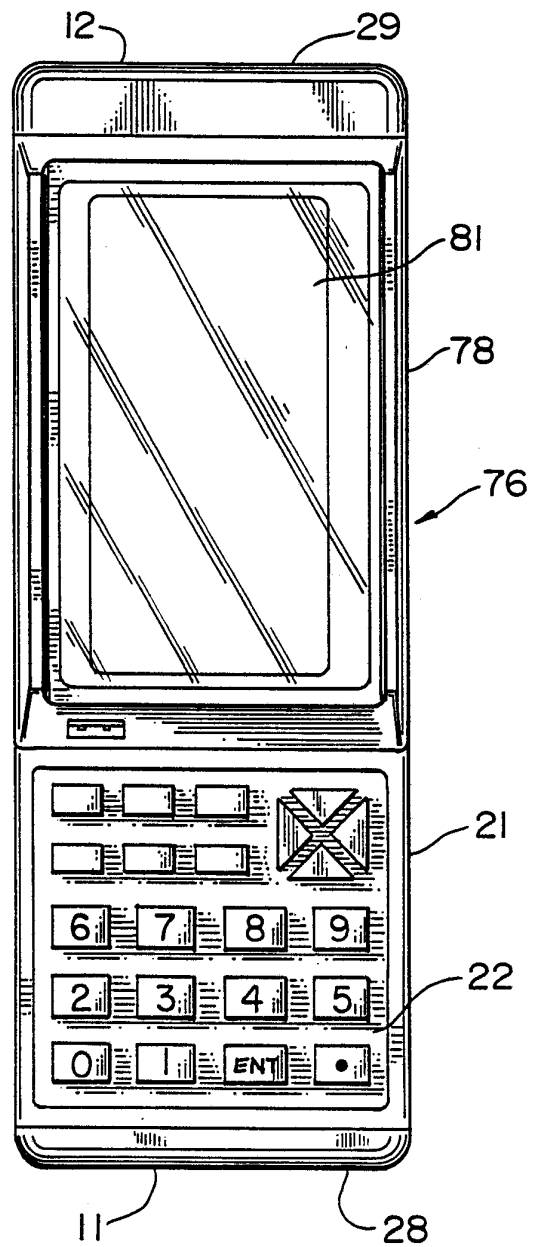


FIG. 9

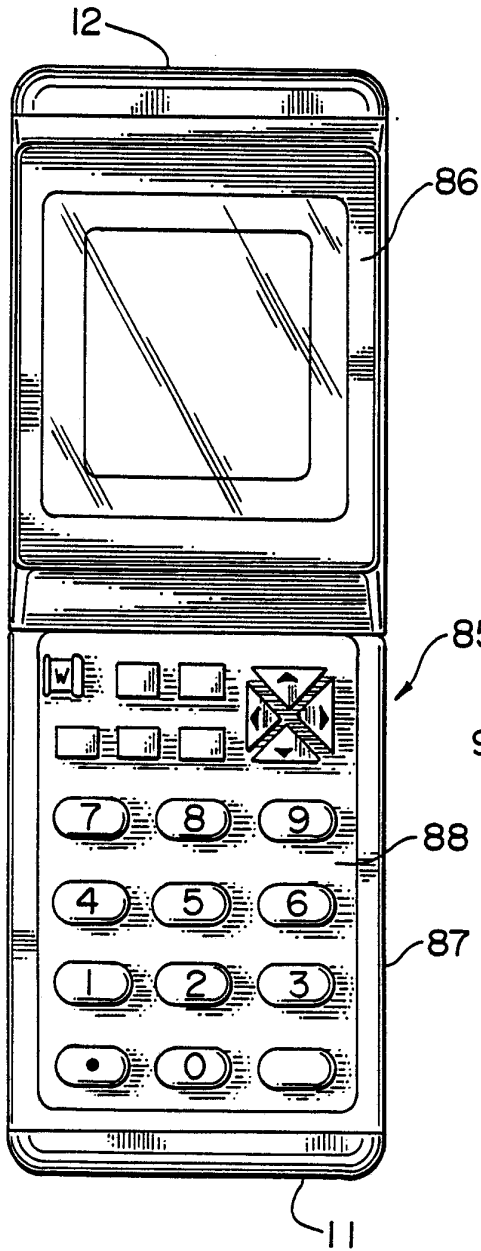


FIG. 10

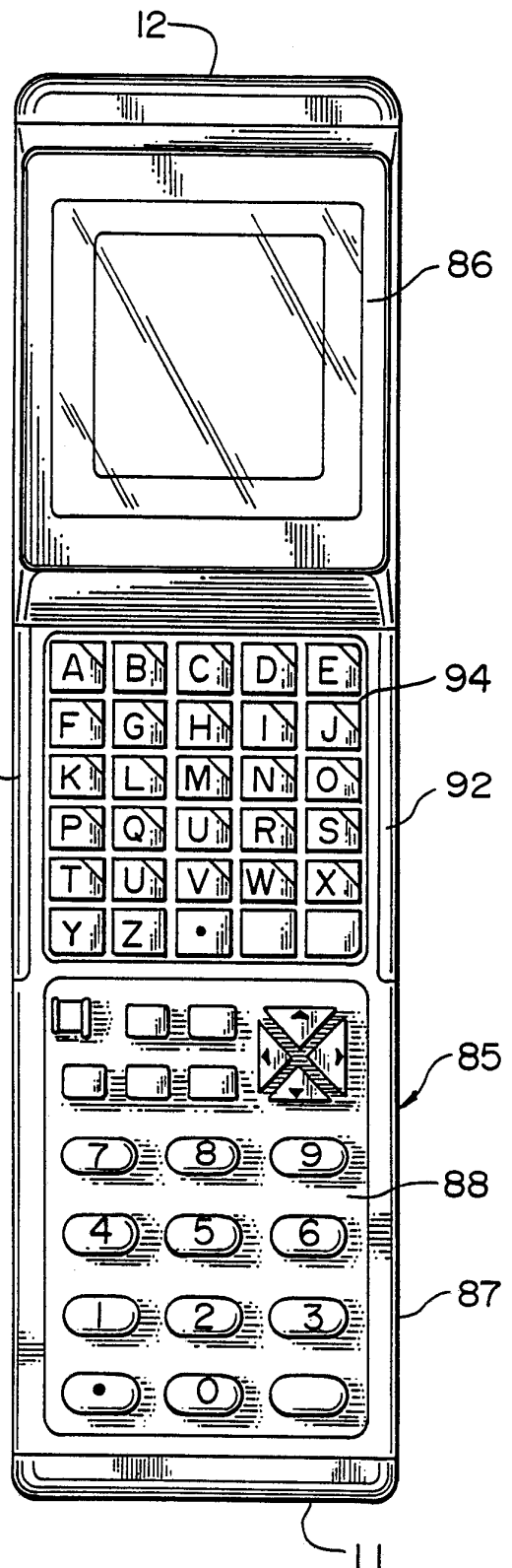


FIG. 11

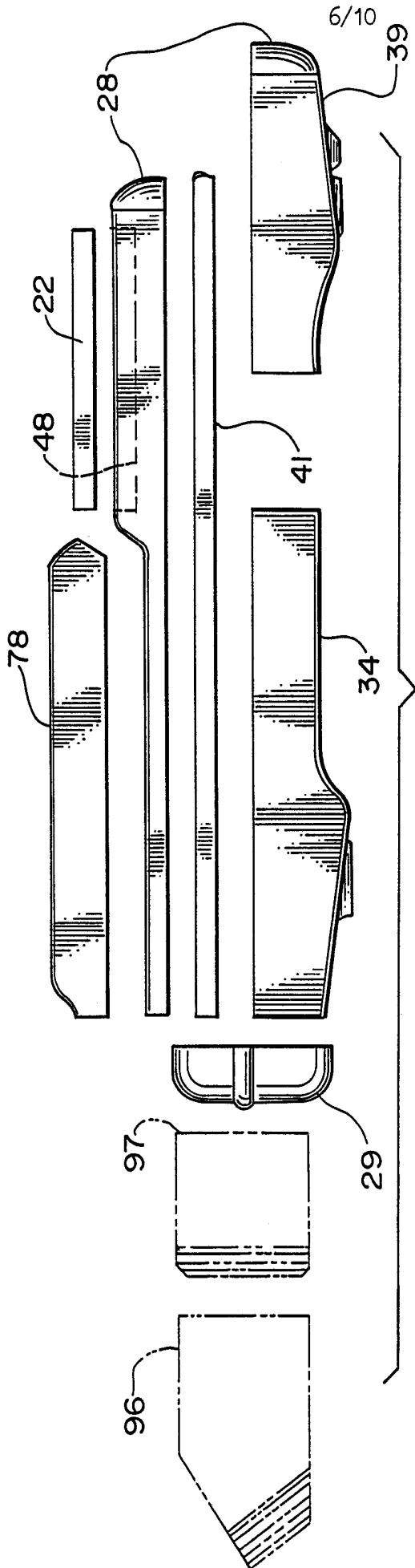
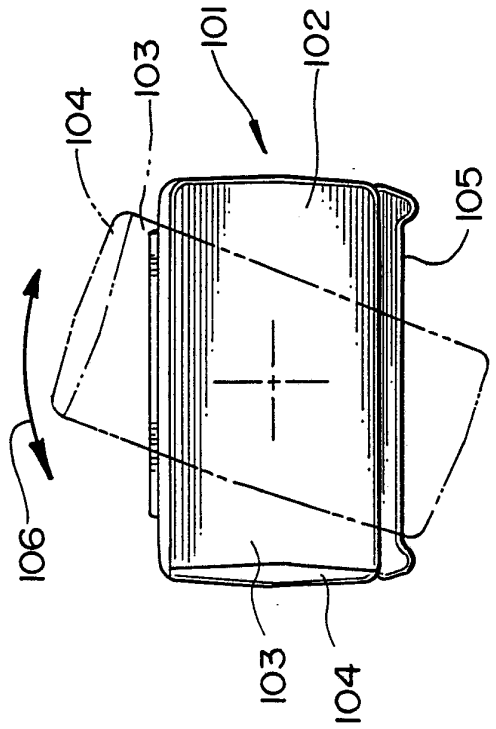
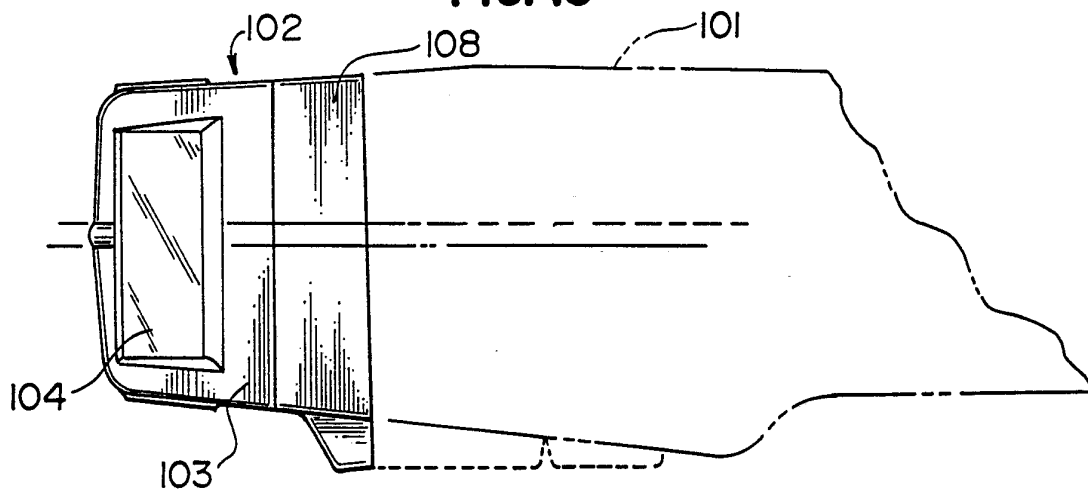


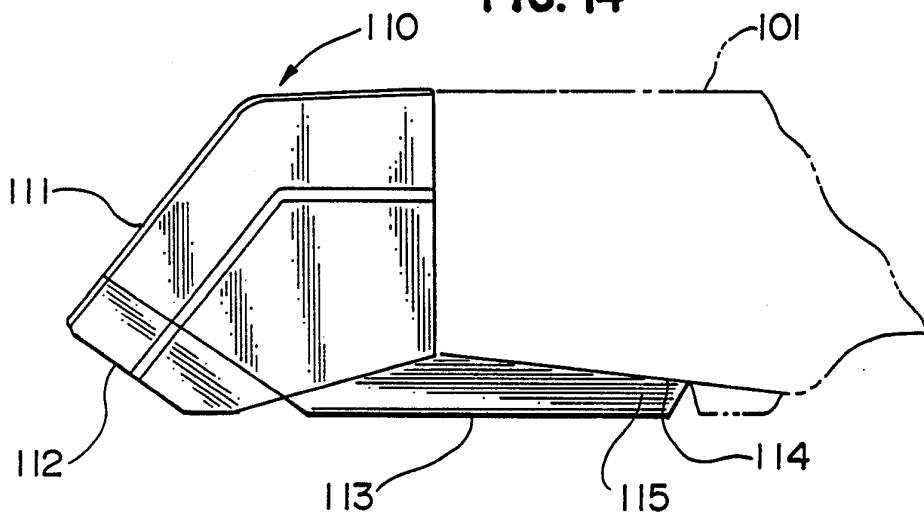
FIG. 12



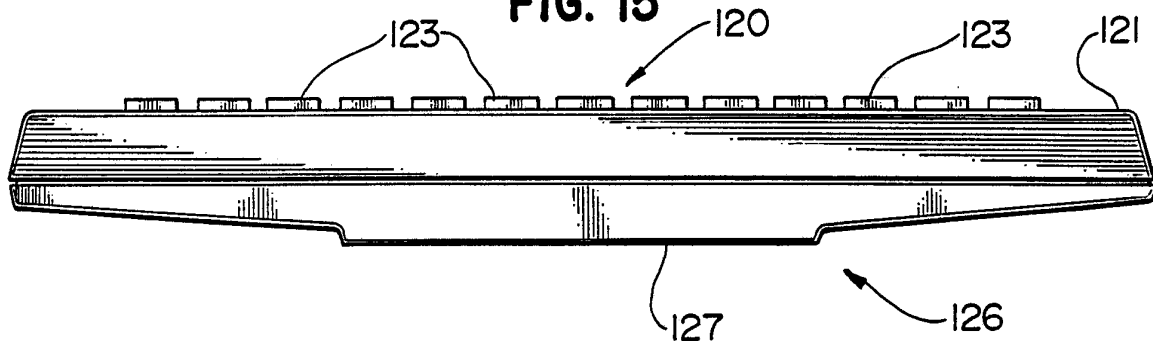
**FIG. 13**

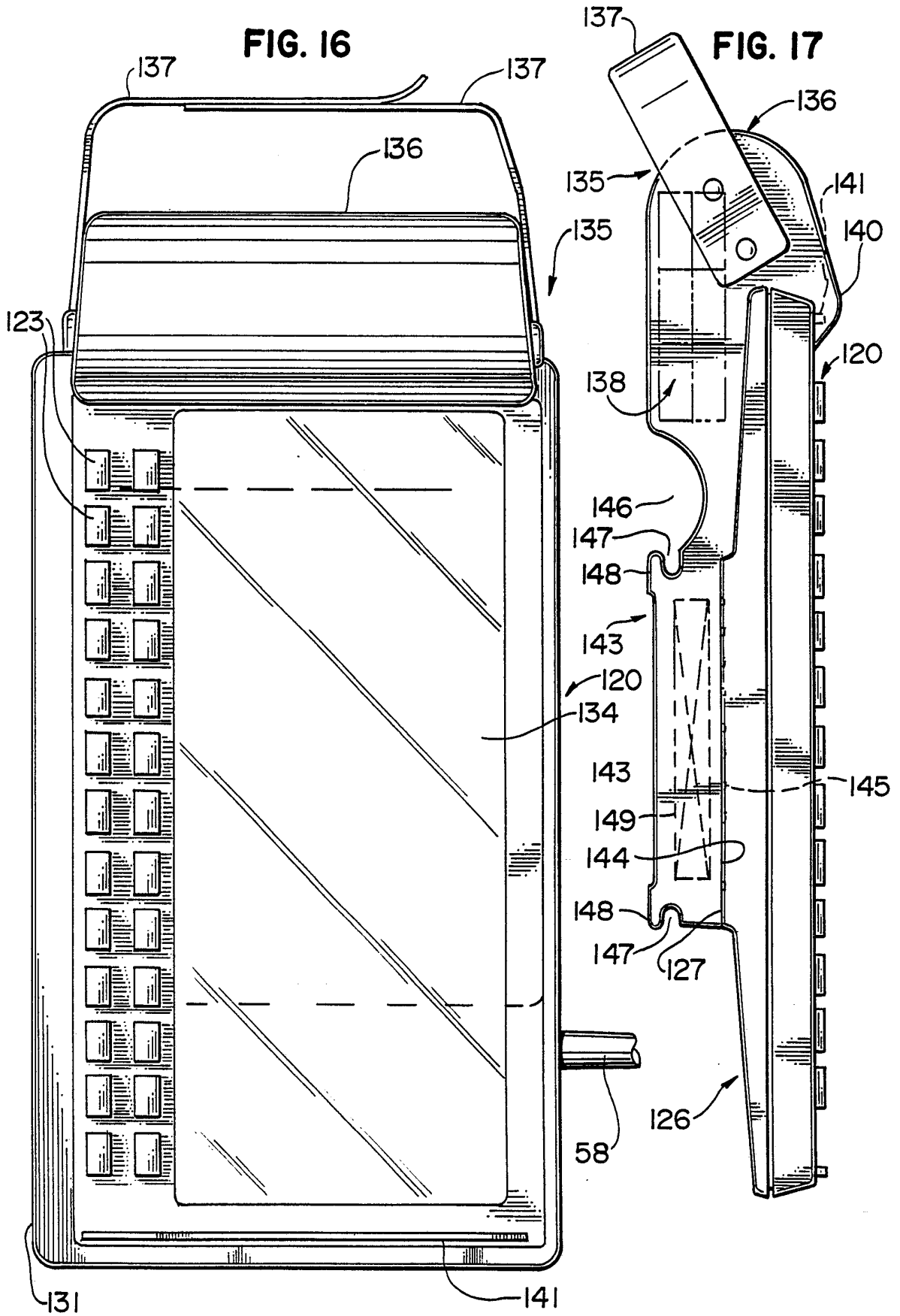


**FIG. 14**



**FIG. 15**





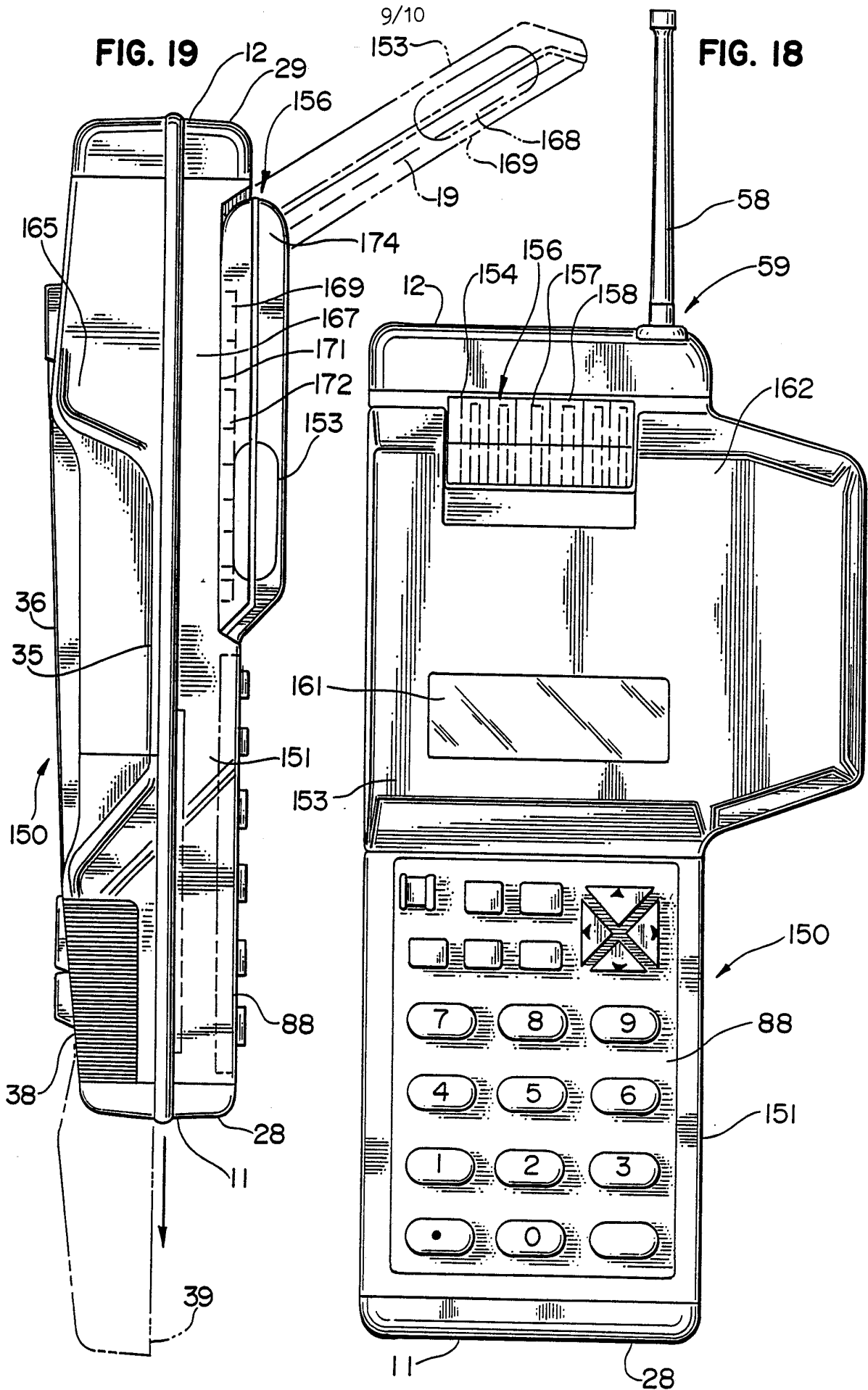
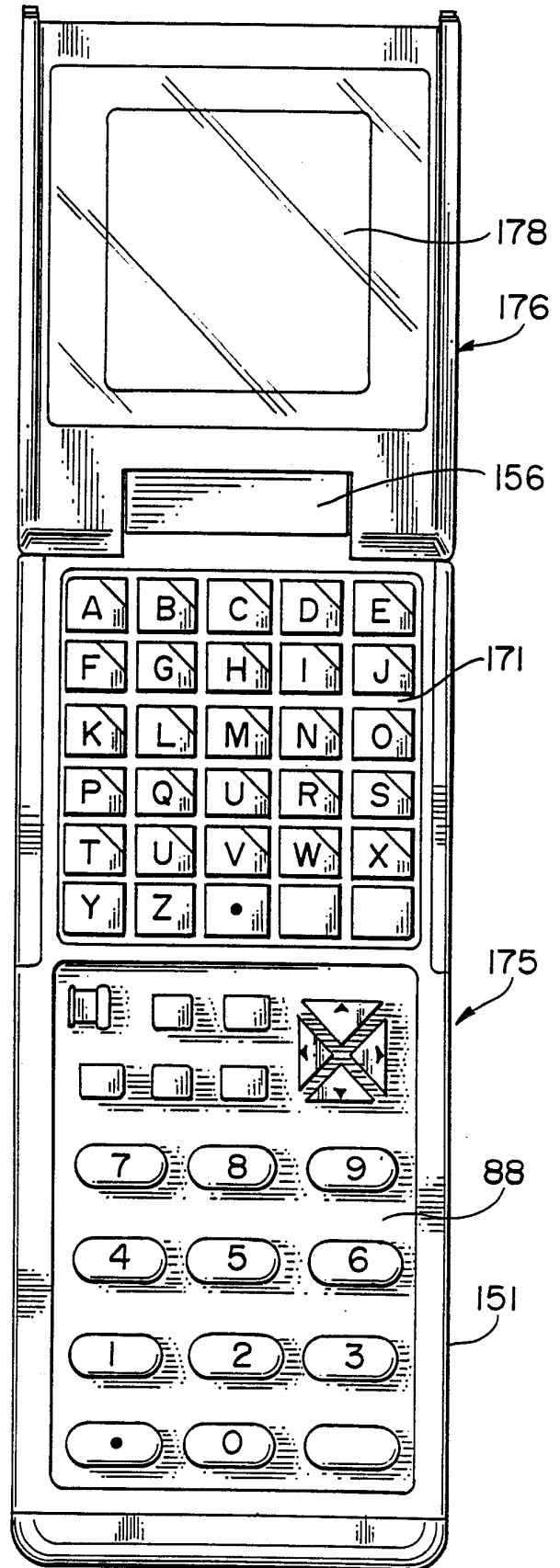
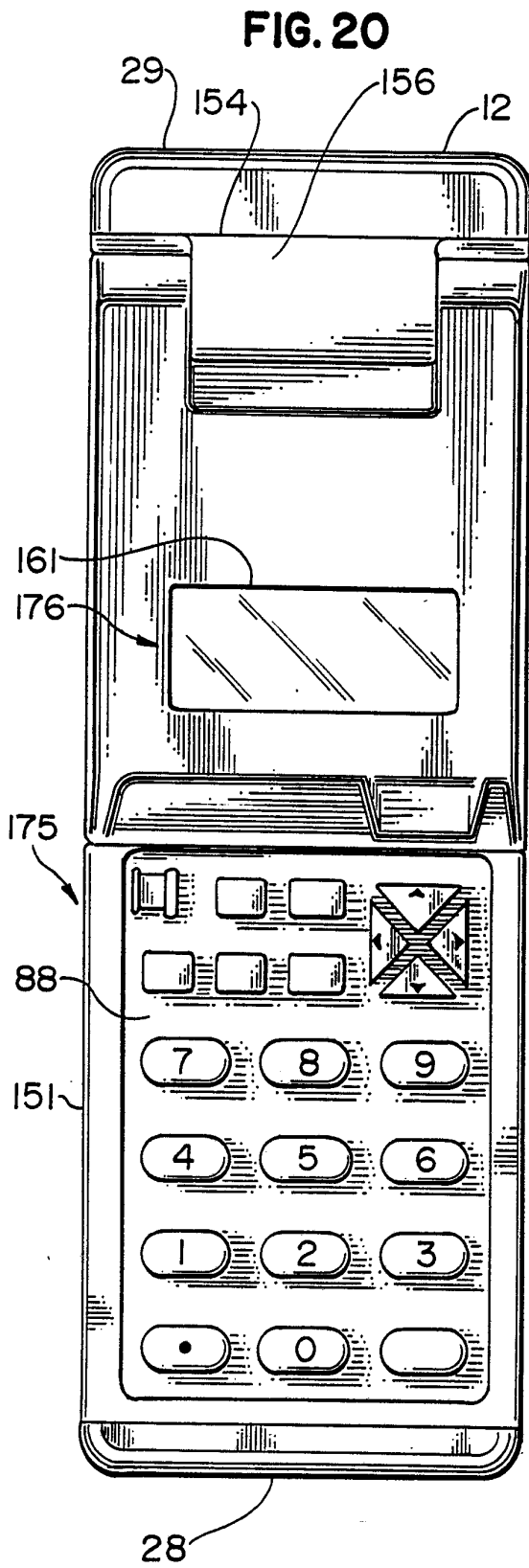




FIG. 21



INTERNATIONAL SEARCH REPORT

International Application No

PCT/US 91/09421

<b>I. CLASSIFICATION OF SUBJECT MATTER</b> (if several classification symbols apply, indicate all) <sup>6</sup>		
According to International Patent Classification (IPC) or to both National Classification and IPC Int.Cl. 5 G06F15/02		
<b>II. FIELDS SEARCHED</b>		
Minimum Documentation Searched <sup>7</sup>		
Classification System	Classification Symbols	
Int.Cl. 5	G06F	
Documentation Searched other than Minimum Documentation to the Extent that such Documents are Included in the Fields Searched <sup>8</sup>		
<b>III. DOCUMENTS CONSIDERED TO BE RELEVANT<sup>9</sup></b>		
Category <sup>10</sup>	Citation of Document, <sup>11</sup> with indication, where appropriate, of the relevant passages <sup>12</sup>	Relevant to Claim No. <sup>13</sup>
E	WO,A,9 016 033 (NORAND CORP.) 27 December 1990 cited in the application  see page 2, line 11 - page 5, line 30 see page 24, line 19 - line 22 see page 25, line 37 - page 26, line 3 see page 28, line 19 - line 30 see page 32, line 15 - line 28; figures 20-31	1-11, 14, 15, 17-20, 25, 26
X	& CA,A,2 020 357 8 December 1990	
X	& CA,A,2 018 154 8 December 1990	
A	US,A,4 220 992 (BLOOD ET AL.) 2 September 1980 see column 2, line 33 - line 37 see column 3, line 46 - line 64 --- -/--	10, 25, 26
<p><sup>10</sup> Special categories of cited documents:</p> <p>"A" document defining the general state of the art which is not considered to be of particular relevance</p> <p>"E" earlier document but published on or after the international filing date</p> <p>"L" document which may throw doubts on priority claim(s) or which is cited to establish the publication date of another citation or other special reason (as specified)</p> <p>"O" document referring to an oral disclosure, use, exhibition or other means</p> <p>"P" document published prior to the international filing date but later than the priority date claimed</p> <p>"T" later document published after the international filing date or priority date and not in conflict with the application but cited to understand the principle or theory underlying the invention</p> <p>"X" document of particular relevance; the claimed invention cannot be considered novel or cannot be considered to involve an inventive step</p> <p>"Y" document of particular relevance; the claimed invention cannot be considered to involve an inventive step when the document is combined with one or more other such documents, such combination being obvious to a person skilled in the art.</p> <p>"&amp;" document member of the same patent family</p>		
<b>IV. CERTIFICATION</b>		
Date of the Actual Completion of the International Search	Date of Mailing of this International Search Report	
15 APRIL 1992	14. 05. 92	
International Searching Authority	Signature of Authorized Officer	
EUROPEAN PATENT OFFICE	Alfredo Prein	

III. DOCUMENTS CONSIDERED TO BE RELEVANT (CONTINUED FROM THE SECOND SHEET)		
Category °	Citation of Document, with indication, where appropriate, of the relevant passages	Relevant to Claim No.
A	WO,A,8 707 106 (CLINICOM INCORPORATED) 19 November 1987  see page 3, line 17 - page 5, line 4 see page 6, line 19 - line 26; figure 1 ---	1,5-7, 15,17, 18,20, 25,26
A	US,A,4 517 660 (H. FUSHIMOTO ET AL.) 14 May 1985  ---	

**ANNEX TO THE INTERNATIONAL SEARCH REPORT  
ON INTERNATIONAL PATENT APPLICATION NO. US 9109421  
SA 55514**

This annex lists the patent family members relating to the patent documents cited in the above-mentioned international search report. The members are as contained in the European Patent Office EDP file on The European Patent Office is in no way liable for these particulars which are merely given for the purpose of information. 15/04/92

Patent document cited in search report	Publication date	Patent family member(s)	Publication date
WO-A-9016033	27-12-90	AU-A- 5856390	08-01-91
		CA-A- 2020357	08-12-90
		CA-A- 2022976	08-12-91
		CA-A- 2018154	08-12-90
CA-A-2020357	08-12-90	AU-A- 5856390	08-01-91
		CA-A- 2022976	08-12-91
		WO-A- 9016033	27-12-90
		CA-A- 2018154	08-12-90
CA-A-2018154	08-12-90	AU-A- 5856390	08-01-91
		CA-A- 2020357	08-12-90
		WO-A- 9016033	27-12-90
US-A-4220992	02-09-80	None	
WO-A-8707106	19-11-87	AU-A- 6547686	01-12-87
		CA-A- 1268253	24-04-90
		US-A- 4850009	18-07-89
US-A-4517660	14-05-85	JP-C- 1355022	24-12-86
		JP-A- 56137461	27-10-81
		JP-B- 61019053	15-05-86
		JP-C- 1323074	27-06-86
		JP-A- 56159754	09-12-81
		JP-B- 60046464	16-10-85