



Europäisches Patentamt
European Patent Office
Office européen des brevets



(11) **EP 1 075 419 B1**

(12) **EUROPEAN PATENT SPECIFICATION**

(45) Date of publication and mention
of the grant of the patent:

29.10.2003 Bulletin 2003/44

(21) Application number: **98939187.5**

(22) Date of filing: **03.08.1998**

(51) Int Cl.7: **B65B 17/02**

(86) International application number:
PCT/US98/16162

(87) International publication number:
WO 99/006280 (11.02.1999 Gazette 1999/06)

(54) **PACKAGING MACHINE AND METHOD OF CARTON SET UP**

VERPACKUNGSMASCHINE UND VERFAHREN ZUM AUFSETZEN VON KARTONS

MACHINE D'EMBALLAGE ET PROCEDE DE MONTAGE DE CARTONS

(84) Designated Contracting States:
**AT BE CH CY DE DK ES FI FR GB GR IE IT LI NL
PT SE**

(30) Priority: **01.08.1997 GB 9716324**

(43) Date of publication of application:
14.02.2001 Bulletin 2001/07

(60) Divisional application:
03006307.7 / 1 342 668

(73) Proprietor: **MeadWestvaco Packaging Systems
LLC
Stamford, Connecticut 06905 (US)**

(72) Inventors:
• **CHALENDAR, Eric
F-36000 Chateauroux (FR)**
• **LAMAMY, Michel
F-36120 Saint AouÛt (FR)**

(74) Representative: **Hepworth, John Malcolm
Hepworth Lawrence Bryer & Bizley
Bloxam Court
Corporation Street
Rugby, Warwickshire CV21 2DU (GB)**

(56) References cited:
WO-A1-97/18993 **US-A- 3 242 827**
US-A- 4 848 061 **US-A- 5 415 615**

EP 1 075 419 B1

Note: Within nine months from the publication of the mention of the grant of the European patent, any person may give notice to the European Patent Office of opposition to the European patent granted. Notice of opposition shall be filed in a written reasoned statement. It shall not be deemed to have been filed until the opposition fee has been paid. (Art. 99(1) European Patent Convention).

Description

[0001] This invention relates to a packaging machine and is particularly useful for processing cartons of the top gripping type which are adapted to accommodate a plurality of articles, for example, four or six glass beverage bottles.

[0002] Top gripping cartons for accommodating glass bottles normally have side (and end) walls adapted to form a substantially rigid tubular structure. It is often desirable to use a so called clip type article carrier to transport the grouped articles. The clip type carrier is normally provided with at least one aperture to receive an upper portion of the article. In some embodiments, tabs are used to engage the underside of the flange of an article to lock the article in the carton. Optionally, tabs are used to maintain the carton in a set up condition.

[0003] Such cartons incorporate a midriff fold line about which the cartons are hinged when erected from a flat condition into a set up condition ready for loading. There is a tendency for the cartons to collapse back to their flat condition during or immediately after set up prior to loading and it is necessary to set up the carton and to support the carton immediately after set up so that this tendency to collapse is mitigated.

[0004] In one example shown in US4,848,061 there is shown a mechanism and method for applying a top gripping carrier to an array of articles in a continuous forward movement.

[0005] The invention provides a device for transferring a carton from a carton set up station to a carton loading station in a packaging machine comprising conveying means for conveying a carton between the stations and means for receiving and retaining at least one carton to be transferred between stations. The conveying means comprises guide means connected to the carton receiving means and a guide track for receiving the guide means, the guide track being adapted to guide the guide means and the receiving means to receive and retain at least one carton to transfer the carton to the loading station, to locate the carton at the loading station for loading the carton with at least one article.

[0006] Further, it is necessary to transfer the cartons from a set up station to a loading station. The packaging machine according to the present invention is adapted to feed successive cartons onto a loading station sited on a crate conveying line. The cartons are interengaged with bottles contained within these crates during continuous forward feed. Thus, it is necessary to provide a packaging machine that performs a number of carton set up and loading functions.

[0007] The machine is readily adjustable to accommodate a wide range of carton sizes without undue time being taken to adapt the machine from running one size of carton to running a different size of carton.

[0008] According to an optional feature of this aspect of the invention, the device may comprise control means for controlling the conveying means so that the carton

is loaded during continuous forward movement.

[0009] According to another optional feature of this aspect of the invention, the at least one article may be conveyed to the loading station by second conveying means and wherein the control means controls the second conveying means for continuous forward movement of the articles.

[0010] According to another optional feature of this aspect of the invention, the device may further comprise a second guide means and guide track positioned at the loading station being oppositely disposed the first guide means and guide track, the second guide means and guide track is provided to load the cartons with at least one article.

[0011] Optionally, the guide means may comprise a roller follower.

[0012] According to another optional feature of this aspect of the invention, the carton receiving means may comprise carton engagement means, connected to a reciprocating arm capable of raising and lowering the carton engagement means between the stations.

[0013] According to another optional feature of this aspect of the invention, the carton engagement means may comprise at least one suction cup and cup holder, the at least one suction cup being connected to a vacuum supply during the carton engagement.

[0014] An embodiment of the invention will now be described, by way of example only, with reference to the accompanying drawings in which:

FIGURE 1 is a perspective view of a machine according to the invention from a point of view wherein the upstream end of the machine is positioned to the left;

FIGURE 2 is a perspective view of the machine shown in Figure 1 from a point of view wherein the downstream end of the machine is positioned to the right;

FIGURES 3a and 3b are perspective views of top gripping type cartons suitable for use with a machine according to the invention;

FIGURE 4 is a perspective view of the carton supply/feed and setting up station of the machine shown in Figure 1;

FIGURE 5 is a perspective view of the end panel erection station of the machine shown in Figure 1;

FIGURE 6 is a perspective view of the carton loading station and crate conveying lines;

FIGURE 7 is a perspective view of the outfeed end of the machine according to the invention;

FIGURE 8 is a perspective view of the vacuum

plunger support assembly;

FIGURES 9 a, b and c are views showing the detail of the vacuum plunger support assembly;

FIGURE 10 is a perspective view of the vacuum plunger device at the upstream end of the machine according to the invention; and

FIGURE 11 is a perspective view of the vacuum plunger device at the downstream end of the machine according to the invention.

[0015] As shown in Figures 1 and 2, the cartons are fed into the machine in one direction X and the cartons are erected and then direction of carton flow is reversed to enable the cartons to be packaged with articles held in crates moving in an opposite direction Y to the carton infeed. The infeed and outfeed ends of the machine are adjacent. It is apparent from the drawings that this configuration results in a machine that uses less floor area in a bottling plant, often an important commercial consideration in machine selection.

[0016] Referring to the drawings and in particular, Figures 1 and 2, there is shown a packaging machine 2 for continuously setting up and loading top gripping type cartons 10 into a crate 82 containing at least one article B wherein the carton 10 is continuously moved downstream by carton conveying means 50, which machine comprises feed means 36 sequentially to deliver successive cartons 10 from a supply 34 in flat collapsed condition to a setting up station S of the machine, means 36 to restrain upper portions of the carton relative to the lower portions thereof so that lower portions are moved away from said upper portions to bring the carton into a set up condition, means 38 to group at least one said carton as it is moved downstream, means 92 for transferring said grouped cartons 32 to said crate 82 and means 98, 124 for locating and locking each said carton over neck portions of at least one article B contained within said crate 82.

[0017] A top gripping type carton 10 is illustrated in Figure 3a, which is packaged in a machine of the present invention. The carton 10 is formed from a unitary blank made from paperboard or similar sheet material. The carton 10 includes a top panel 12, a first side wall panel 14, base panel 16 and a second side wall 18 hingeably connected one to next to form a tubular structure. The ends of the carton are closed by an end panel flap structure generally shown by reference numerals 20 and 22 at respective ends of the carton. Six apertures 24, 25 are formed in both the top and bottom panels 12, 16. Locking tabs 26, 27 extend from the upper edge of end panels 20, 22. The apertures of the top panel are in registry with corresponding apertures of the bottom panel and are adapted to receive and retain six articles arranged in two rows of three articles.

[0018] It is envisaged that the carton can vary de-

pending upon the shape and/or quantity of the articles to be packaged and accordingly, a machine in accordance with the present invention is adjustable in numerous respects, so that it can process a wide variety of such cartons. The principle dimensions which are likely to be varied are shown in Figure 3a in which "H" is the overall height of the set up carton equivalent to the distance between the top panel and the base panel, "L" is the overall length of the carton when the end flaps are closed. For example, the packaging of four articles is achieved by using a carton as shown in Figure 3b.

[0019] Referring again to Figures 1 and 2 of the drawings, there is shown a machine 2 for processing cartons 10 of the type outlined above. The carton 10 is supplied in a flat collapsed condition about fold lines 28 and 29 such that the top panel 12 and first side panel 14 are in a face contacting relationship with second side panel 18 and base panel 20.

[0020] The upstream end of the machine, shown in Figure 4, includes a hopper 34 in which a multiplicity of cartons 10 in flat collapsed condition are held in two or three rows ready for processing. The cartons are removed from the hopper in pairs or trio by a rotary vacuum feeder 36 fed two or three at a time on to a carton conveyor 38. In the embodiment illustrated, the rotary feeder 36 comprises four pairs of suction cups 40 interconnected to a drive shaft 42 by drive rods 44 fixed on a device 44a turning freely around drive shaft 42. Drive rods 44 slide freely through a device which supports suction cups 40. The suction cups 40 and drive rods 44 are connected to cam track 46 and cam followers 48 which provide a uniform path for the suction cups 40 when the main shaft 42 is rotated. Thus, a pair or trio of collapsed cartons is removed from the hopper in direction A illustrated in Figure 4 such that top and bottom walls of each collapsed carton are separated by centrifugal force as the collapsed cartons are rotated. The collapsed cartons are rotated at sufficient velocity for the top and bottom panels to be moved apart, thus partly erecting the cartons. It will be appreciated that other rotary feeders, for example EP 0 429 231 can be used instead without departing from the scope of the invention.

[0021] In this embodiment, the carton conveyor 38 is adapted to group two pairs of cartons 32 together. The conveyor 38 moves each group forward to be transferred to an overhead vacuum plunger unit 50, described below. The carton conveyor 38 comprises an endless chain 52 driven by suitable drive means, for example a servo motor (not shown) and an endless series of leading and trailing lugs 54, 56 for receiving the adjacent cartons and maintaining the side walls 14, 18 in a substantially vertical spaced relationship. As illustrated in Figure 4, the leading side wall 14 comes into contact with the leading lug 54, the trailing lug 56 assumes a position immediately behind the cartons which is, of course, in a set up fully open condition. It will be appreciated that the leading and trailing lugs 54, 56 can con-

tribute to the manipulation of the cartons into a set up condition.

[0022] As illustrated in Figure 4, a second pair of cartons is preferably placed in the lugs 55, 57 immediately behind the first pair of cartons. Thus, the cartons are grouped into fours or sixes by providing a spacing between lug sets 59. It is envisaged that the numbers of the cartons contained within a group can be altered according to the particular requirements of the machine.

[0023] The group of cartons 32 is then transferred by an overhead vacuum plunger unit 50 (described in greater detail below) to the end panel erection station E, illustrated in Figure 4 and 5. The end panels 20, 22 are erected by lowering the grouped cartons onto at least one vertically oriented guide pin 62, 64. Preferably, the guide pins 62, 64 pass through the end most apertures 24 of each carton and come into contact with the end panels 20, 22. As the cartons are lowered further, the guide pins 62, 64 push the end panels 20, 22 in an upwards and outwards direction until the end panel tabs 26, 27 pass through upper apertures 24 and are locked in place with respective apertures. Thus, the cartons are in a set up condition shown in Figure 1.

[0024] Each set of guide pins 62 is mounted on an endless chain or conveyor belt (or chain set) 66 driven by suitable drive means for example servo motors (not shown) to provide an upper surface that moves forward at the same velocity as the overhead unit 50. Thus, the grouped cartons 32 can be lowered onto the guide pins 62, 64 to erect the end panels whilst they are being moved downstream by the overhead unit 50.

[0025] Turning in detail to the construction of the guide pins 62, 64, two pairs of guide pins 62 are positioned along opposed transverse end edges of the conveyor belt 66 being adapted to receive the outer end panels of a pair of adjacent cartons. In a central region of the conveyor 66, two further pairs of guide pins 64 are positioned to receive the inner end panel of each carton. Likewise, pairs of guide pins 68, 70 are mounted on the conveyor 66 in close proximity to and in corresponding locations to the four pairs of guide pins 62, 64 described above. The second set of guide pins 68, 70 are adapted to receive the rear mounted pair of cartons, as illustrated in Figure 5. It is envisaged that the guide pins can be altered in number and location to accommodate cartons of differing size and shape. Preferably, the conveyor 66 can be removed as a unit and replaced with an alternative configuration of guide pins thereby reducing change over time and machine down time.

[0026] Each group of erected cartons is then transferred to the crate conveying line 80, illustrated in Figure 6 and 7, to be packaged *in situ* with articles, for example bottles, contained in each crate 82. In this embodiment, the crates 82 comprise 24 bottles B contained within individual cells of the crate. The crates 82 are fed into the packaging machine sequentially with the throughput being controlled by lugs 84 connected to endless chains 86 mounted on either side of the crates 82. The lugs 84

retain the crates 82 until a suitable spacing is achieved with the preceding crate. The endless chains 86 are powered by suitable drive means for example, servo motor which is preferably controlled by suitable control means. Accordingly, the throughput of the crates is timed to operate with the grouped articles 32 being conveyed by unit 50.

[0027] The crate is then able to move onto a second endless chain 87 with leading and trailing lugs 88, 89 to guide each crate 82 through the packaging machine. As the crate 82 is conveyed to the outfeed end of the machine, the group of cartons 32 are introduced to the crate 82 from above and lowered over upper portions of each bottle B. At this stage, the crate and the grouped cartons 32 are brought into vertical alignment and the cartons are progressively lowered onto the upper portion of the bottles B, as the crate moves forward. Thus, the bottles B are aligned with the apertures 24, 25 and are lowered through the lower apertures and then upper apertures until tabs 26, 27 are engaged on the underside of a protruding part of an upper portion of the bottles, for example the crown corks. It will be appreciated that in this embodiment, each crate 82 holds four cartons carrying six bottles each or six cartons carrying four bottles each.

[0028] The vacuum plunger 90 is then released from the cartons, thereby leaving the cartons 32 within the crate 82 as it moves to the outfeed end of the packaging machine.

[0029] Turning to the detail of the overhead unit 50 shown in Figures 8, 9a-c, 10 and 11. The unit 50 comprises a plurality of vacuum plunger devices 90, each of which is of a similar form and is carried by upper and lower endless chain and sprocket sets 92, 94 powered by suitable drive means, for example servo motors (not shown). Thus, the plunger devices 90 are caused to move continuously around the unit 50.

[0030] A vacuum plunger device 90 is illustrated in Figure 8 and 9a-c. The device comprises a series of suction cups 96 mounted onto the vacuum plate 98. In this embodiment, the vacuum plate 98 incorporates twelve suction cups 96 adapted to hold four cartons shown in Figure 9c. The suction cups 96 are arranged in two rows, each row holding a pair of adjacent cartons. At each end of the vacuum plate 98, there are a series of support guides 100 that are connected to the leading and trailing edges 102, 104 of the vacuum plate 98. In use, these guides 100 retain the leading and trailing side panels 14, 18 of the grouped cartons.

[0031] The suction cups 96 are connected to a vacuum source via a coupling 106. Figure 9a illustrates the completed vacuum cup plate 98. As shown in Figure 8, the vacuum plate 98 is mounted to a support frame 108 of the vacuum plunger device 90. Pegs (not shown) extending from the support frame 108 are interengaged with apertures 110 provided in the vacuum plate 98. The arrangement of the pegs and apertures 110 provides for easy attachment and removal of the plate 98 to and from the frame 108.

[0032] The support frame 108 is mounted to the lower extremity of a pair of reciprocating arms 112, 113. Both reciprocating arms 112, 113 are mounted to a fixed plate 114 comprising a pair of mounting brackets 116, 118 disposed in upper and lower portions of the fixed plate 114. Each reciprocating arm 112, 113 passes through the pair of mounting brackets 116, 118, as shown in Figure 8. The fixed plate 114 is secured at each of its opposite ends to the upper and lower chain and sprocket sets 92, 94 so that the vacuum plunger devices 90 can be caused to move continuously around the unit 50.

[0033] During movement around the unit 50, the vacuum cup plate 98 is caused to be reciprocally moved by means of a cam track 124 disposed between the chain and sprocket sets 92, 94 and engaged by a roller follower 126 carried by the arms 112, 113. A preferred configuration of the cam track 124 is illustrated in Figures 10 and 11. Thus, the vacuum cup plate 98 is moved to the set up station S and is caused to be downwardly extended relative to its mounting brackets 116, 118 so that it can engage the top wall 12 of four cartons below, during which time vacuum is applied to secure the cartons 32 to the suction cups 96. As the plunger device 90 continues to move forward, the vacuum cup plate 98 is retracted so that the part erected cartons 32 can be moved on to the end panel erection station E. As described above, the leading and trailing side panels 14, 18 of the carton are held in place by means of guide pins 100.

[0034] The cam track 124 is configured to lower the vacuum cup plate 98 and cartons 32 on to the end panel erection station E where the end panels are erected as described earlier. Thereafter, the plate 98 is retracted so that the erected cartons are raised and leave the station and are transported to the carton loading station L. The vacuum cup plate 98 is lowered onto a crate 82 loaded with bottles B. The cartons 32 are then engaged with the bottles B as described above.

[0035] In this embodiment, the carton conveyor 38 at the set up station, the guide pin conveyor 66 at the erecting station and the movement of the crates is controlled by suitable control means (not shown) so that their velocities correspond to the forward movement of the vacuum cup plate 98 and cartons 32. In the present embodiment, the time the cartons are required to spend at each station is dictated by the configuration of the cam track 124. As Figure 10 illustrates the vacuum plunger device 90 is in a lowered position for longer at the carton set up station S than the erection station E. Likewise, the angle of lowering the cartons onto the articles is dictated by the cam track 124, which, in this embodiment, is shaped to provide a shallow angle of incline G. It is envisaged that in other embodiments, the angle of incline can be increased (or as the case may be decreased) to decrease (or increase) the loading time.

[0036] Referring again to Figure 11, as the vacuum cup plate 98 is lowered towards the crate 82, a pair of support rails 130, 132 is provided to engage a pair of roller followers 134, 136 mounted onto opposing ends

of the support frame 108. The support rails 130, 132 are optionally included to maintain the support frame 108 in a substantially horizontal plane and to provide positive feed to the cartons 32 as they are moved downwards to interengage with the bottles contained in the crate 82. Likewise, vertical support is provided by support guides 140 and roller followers 142. The vacuum is then relieved so that the vacuum cups 96 disengage the cartons and the vacuum plunger device 92 continues forward to repeat its cyclical reciprocating action. Thus, the cartons are secured to complete the packaging operation. Optionally, sensors (not shown) are provided to ensure that the cartons are in the correct position, in the crate.

[0037] It is envisaged that the packaging throughput of the machine is controlled by computer programme(s) which controls the speed of the upper and lower sprocket sets and the throughput of the crates to ensure the cartons are aligned with the crates. To change the carton size, a different vacuum cup plate 98 is used which can be connected to the machine by means of quick release means outlined above. Thus, the machine down time is minimised.

[0038] A machine according to the present invention is adjustable in a number of respects so as to be able to process cartons containing numerous configurations and groups of articles to create a range of carton size and shape, for example, four bottles to eight bottles without undue amounts of down time being spent in adjusting the machine.

Claims

1. A device for transferring a carton from a carton set up station (S) to a carton loading station (L) in a packaging machine (2) comprising conveying means (50) for conveying a carton between said stations and means for receiving and retaining at least one carton to be transferred between stations, **characterized in that** said conveying means comprises guide means (126) connected to said carton receiving means and a guide track (124) for receiving said guide means, said guide track being adapted to guide said guide means and said receiving means to receive and retain at least one carton to transfer said carton to the loading station (L), to locate said carton at said loading station for loading said carton with at least one article (B).
2. A device according to claim 1 further comprising control means for controlling said carton conveying means (50) so that said carton is loaded during continuous forward movement.
3. A device according to claim 2 wherein said at least one article is conveyed to the loading station (L) by second conveying means and wherein said control

means controls said second conveying means for continuous forward movement of said articles.

4. A device according to any one of claims 1 to 3 where said device further comprises a second guide means and guide track positioned at the loading station (L) being oppositely disposed the first guide means and guide track, said second guide means and guide track is provided to load said cartons with at least one article.
5. A device according to any one of claims 1 to 4 wherein said guide means comprises a roller follower (126).
6. A device according to any preceding claim wherein said carton receiving means comprises carton engagement means (90), connected to a reciprocating arm (112, 113) capable of raising and lowering said carton engagement means (90), between said stations.
7. A device according to claim 6 wherein said carton engagement means (90) comprises at least one suction cup (96) and cup holder, said at least one suction cup being connected to a vacuum supply during said carton engagement.
8. A packaging machine incorporating a device as claimed in any one of claims 1 to 7.

Patentansprüche

1. Vorrichtung zum Überführen einer Schachtel von einer Schachtel-Aufrichtestation (S) zu einer Schachtel-Beladestation (L) in einer Verpackungsmaschine (2), wobei die Vorrichtung eine Fördereinrichtung (50) zum Fördern einer Schachtel zwischen den Stationen umfasst sowie Mittel zum Aufnehmen und Zurückhalten wenigstens einer Schachtel, die zwischen den Stationen bewegt werden soll, **dadurch gekennzeichnet, dass** die Fördereinrichtung Führungsmittel (126) aufweist, die mit den Schachtel-Aufnahmemitteln verbunden sind sowie eine Führungsspur (124) zum Aufnehmen jener Führungsmittel, wobei die Führungsspur angepasst ist, um die Führungsmittel und die Aufnahmemittel zu führen, um wenigstens eine Schachtel aufzunehmen und zurückzuhalten und um die Schachtel zu der Beladestation (L) zu überführen, und um jene Schachtel an jener Beladestation zum Beladen der Schachtel mit wenigstens einem Gegenstand (B) zu lokalisieren.
2. Vorrichtung nach Anspruch 1, die ferner eine Steuerungseinrichtung zum Steuern der Schachtel-Fördereinrichtung 50 umfasst, so dass die Schachtel

während einer fortlaufenden Vorwärtsbewegung befüllt wird.

3. Vorrichtung nach Anspruch 2, wobei der wenigstens eine Gegenstand mittels einer zweiten Beförderungseinrichtung zu der Beladestation (L) befördert wird und wobei die Steuerungseinrichtung die zweite Beförderungseinrichtung für eine fortlaufende Vorwärtsbewegung der Gegenstände steuert.
4. Vorrichtung nach einem der vorhergehenden Ansprüche 1 bis 3, wobei die Vorrichtung weiterhin zweite Führungsmittel einschließt sowie eine Führungsspur, die an der Beladestation (L) angeordnet sind, welche gegenüber der ersten Führungseinrichtung und Führungsspur angeordnet sind, wobei die zweite Führungseinrichtung und die Führungsspur bereitgestellt sind, um die Schachteln mit wenigstens einem Gegenstand zu beladen.
5. Vorrichtung nach einem der Ansprüche 1 bis 4, wobei die Führungseinrichtung einen Rollen-Aufhalter 126 einschließt.
6. Vorrichtung nach irgendeinem der vorhergehenden Ansprüche, wobei die Schachtel-Aufnahmeeinrichtung Schachtel-Ineingriffnahmemittel 90 umfasst, die mit einem sich hinund herbewegenden Arm 112, 113 verbunden sind, der in der Lage ist, zwischen den Stationen die Schachtel-Ineingriffnahmemittel 90 zu heben und zu senken.
7. Vorrichtung nach Anspruch 6, wobei die Schachtel-Ineingriffnahmemittel 90 wenigstens einen Saugnapf 96 und Napfhalter einschließen, wobei der wenigstens eine Saugnapf während der Schachtel-Ineingriffnahme mit einer Unterdruckversorgung verbunden ist.
8. Verpackungsmaschine, die eine Vorrichtung gemäß einem der Ansprüche 1 bis 7 inkorporiert.

Revendications

1. Dispositif destiné à transférer un carton d'un poste de montage de carton (S) à un poste de chargement de carton (L) dans une machine d'emballage (2) comprenant un moyen de convoyage (50) destiné à convoyer un carton entre lesdits postes et un moyen destiné à recevoir et à retenir au moins un carton à transférer entre les postes, **caractérisé en ce que** ledit moyen de convoyage comprend un moyen de guidage (126) relié audit moyen de réception de carton et une glissière de guidage (124) destinée à recevoir ledit moyen de guidage, ladite glissière de guidage étant conçue pour guider ledit moyen de guidage et ledit moyen de réception pour

recevoir et retenir au moins un carton pour transférer ledit carton au poste de chargement (L), pour détecter ledit carton audit poste de chargement afin de charger ledit carton avec au moins un objet (B).

5

2. Dispositif selon la revendication 1, comprenant par ailleurs un moyen de commande destiné à manoeuvrer ledit moyen de convoyage de carton (50), de sorte que ledit carton soit chargé pendant un mouvement d'avance continu. 10
3. Dispositif selon la revendication 2, dans lequel ledit objet au nombre minimum de un est convoyé vers le poste de chargement (L) par un deuxième moyen de convoyage et dans lequel ledit moyen de commande manoeuvre ledit deuxième moyen de convoyage pour un mouvement d'avance continu desdits objets. 15
4. Dispositif selon l'une quelconque des revendications 1 à 3, où ledit dispositif comprend par ailleurs un deuxième moyen de guidage et une deuxième glissière de guidage positionnés au poste de chargement (L), disposés en face du premier moyen de guidage et de la première glissière de guidage, ledit deuxième moyen de guidage et ladite deuxième glissière de guidage étant prévus pour charger lesdits cartons avec au moins un objet. 20
25
5. Dispositif selon l'une quelconque des revendications 1 à 4, dans lequel ledit moyen de guidage comprend un suiveur à galet (126). 30
6. Dispositif selon l'une quelconque des revendications précédentes, dans lequel ledit moyen de réception de carton comprend un moyen de prise de carton (90), relié à un bras à va-et-vient (112, 113) apte à élever et abaisser ledit moyen de prise de carton (90), entre lesdits postes. 35
40
7. Dispositif selon la revendication 6, dans lequel ledit moyen de prise de carton (90) comprend au moins une ventouse (96) et un dispositif de retenue de coupelle, ladite ventouse au nombre minimum de un étant reliée à une source de vide durant ladite prise de carton. 45
8. Machine d'emballage comprenant un dispositif selon l'une quelconque des revendications 1 à 7. 50

55

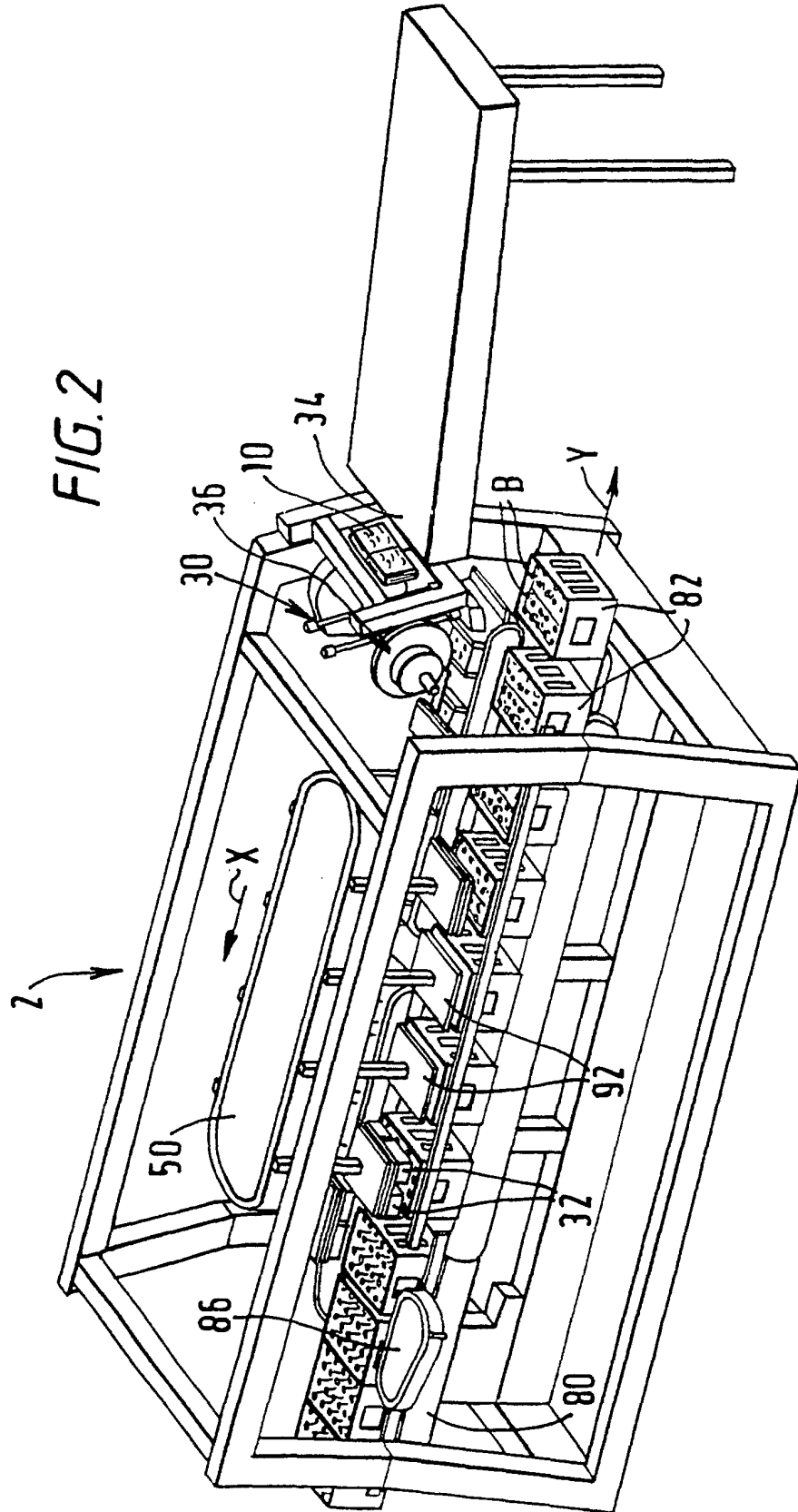

FIG. 3a

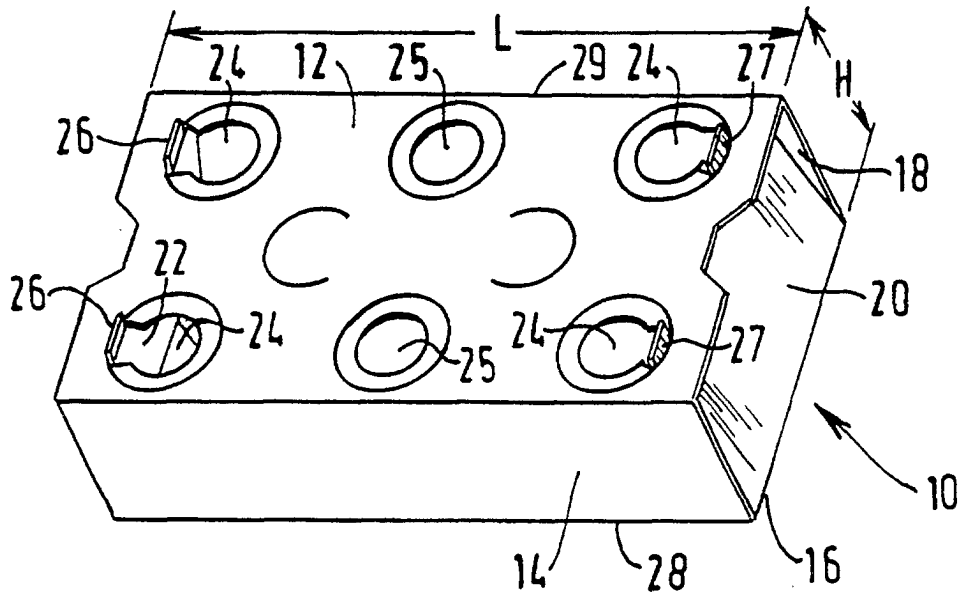

FIG. 3b

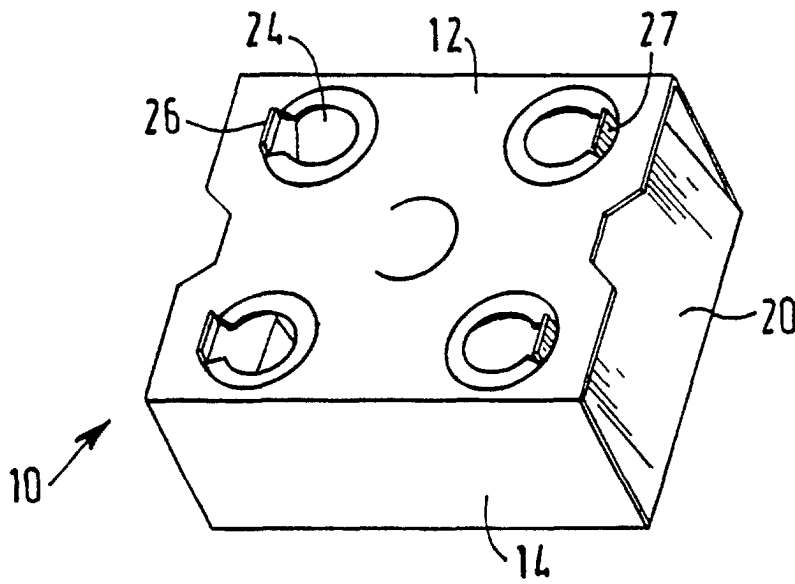
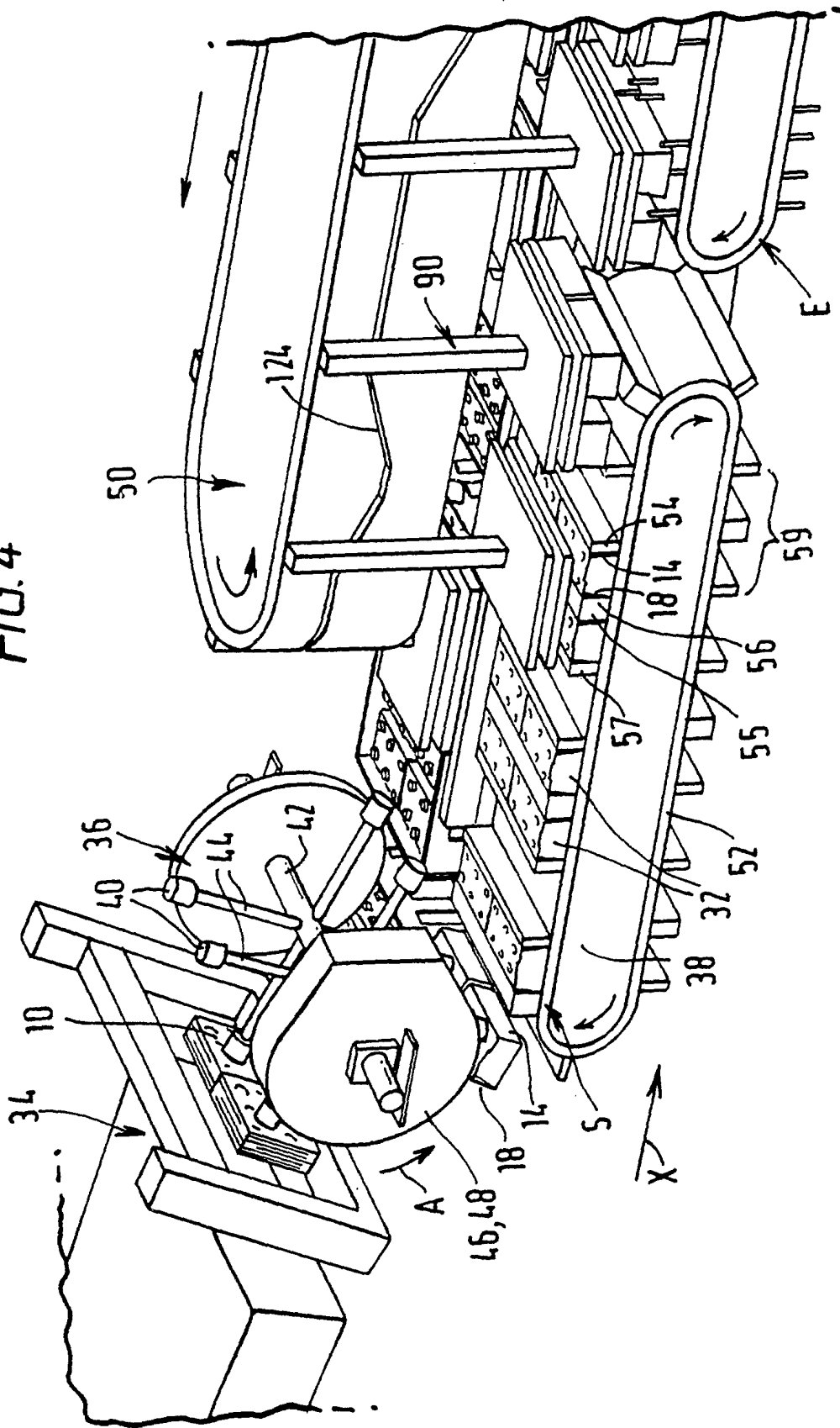
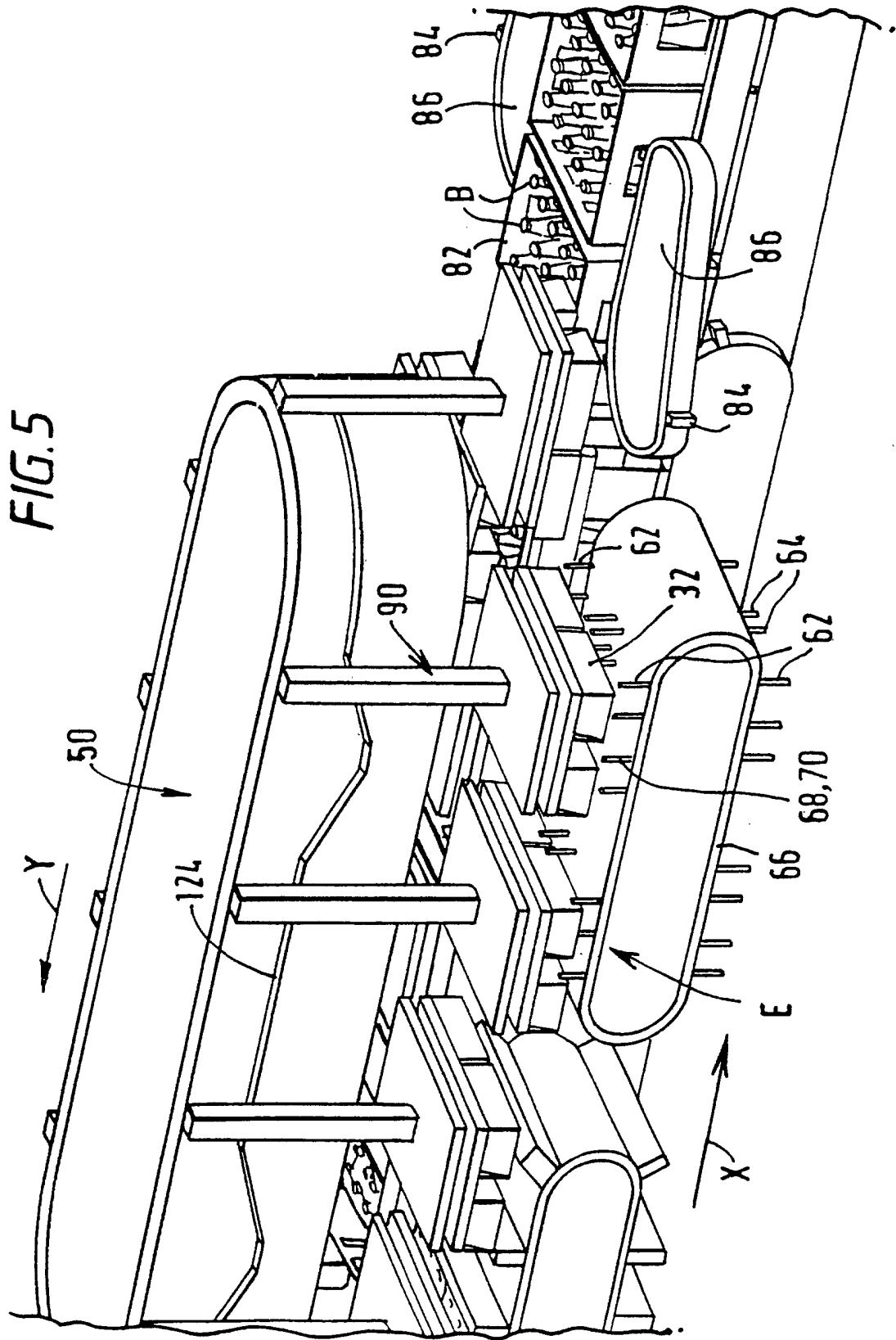

FIG. 4





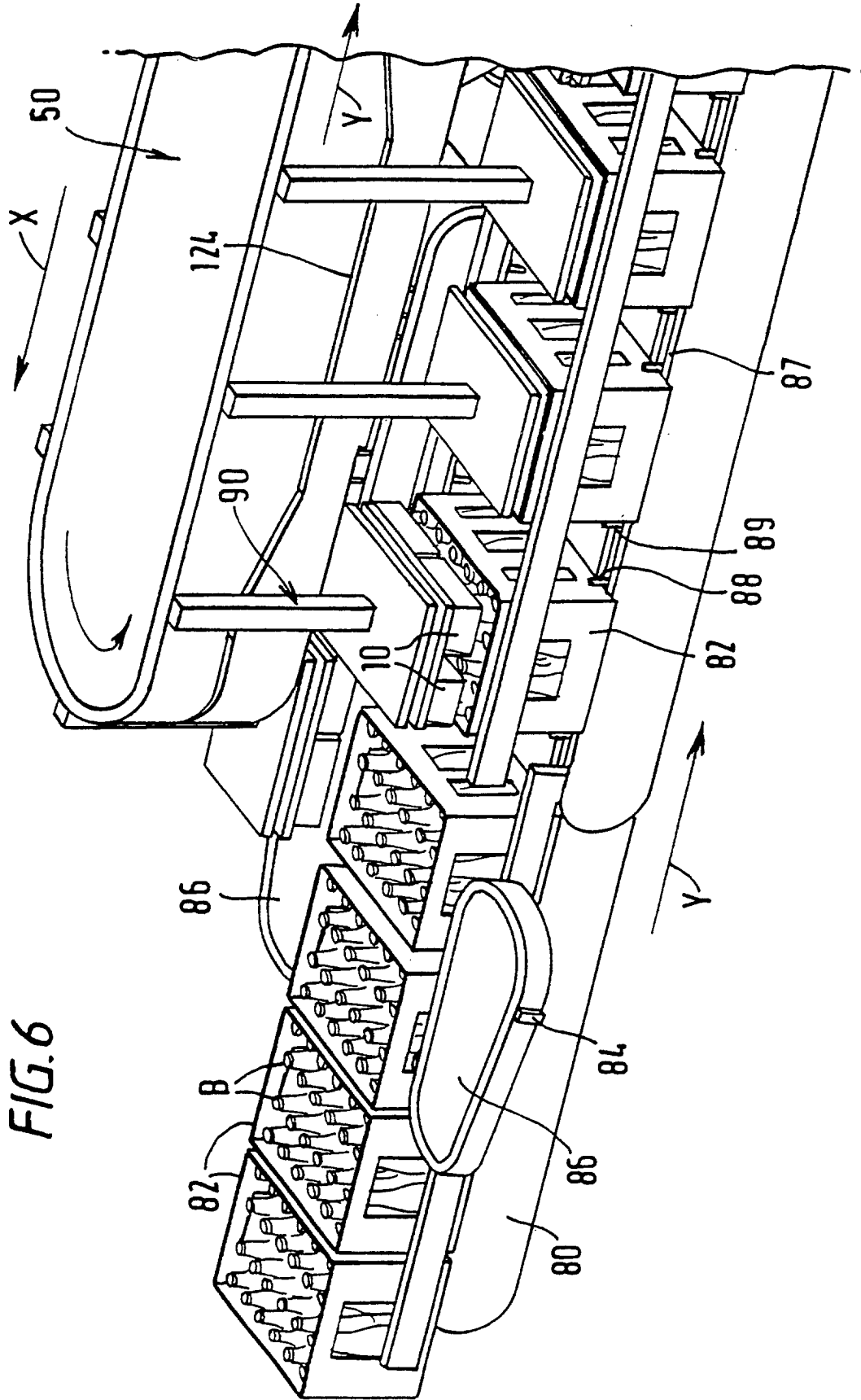

FIG. 6

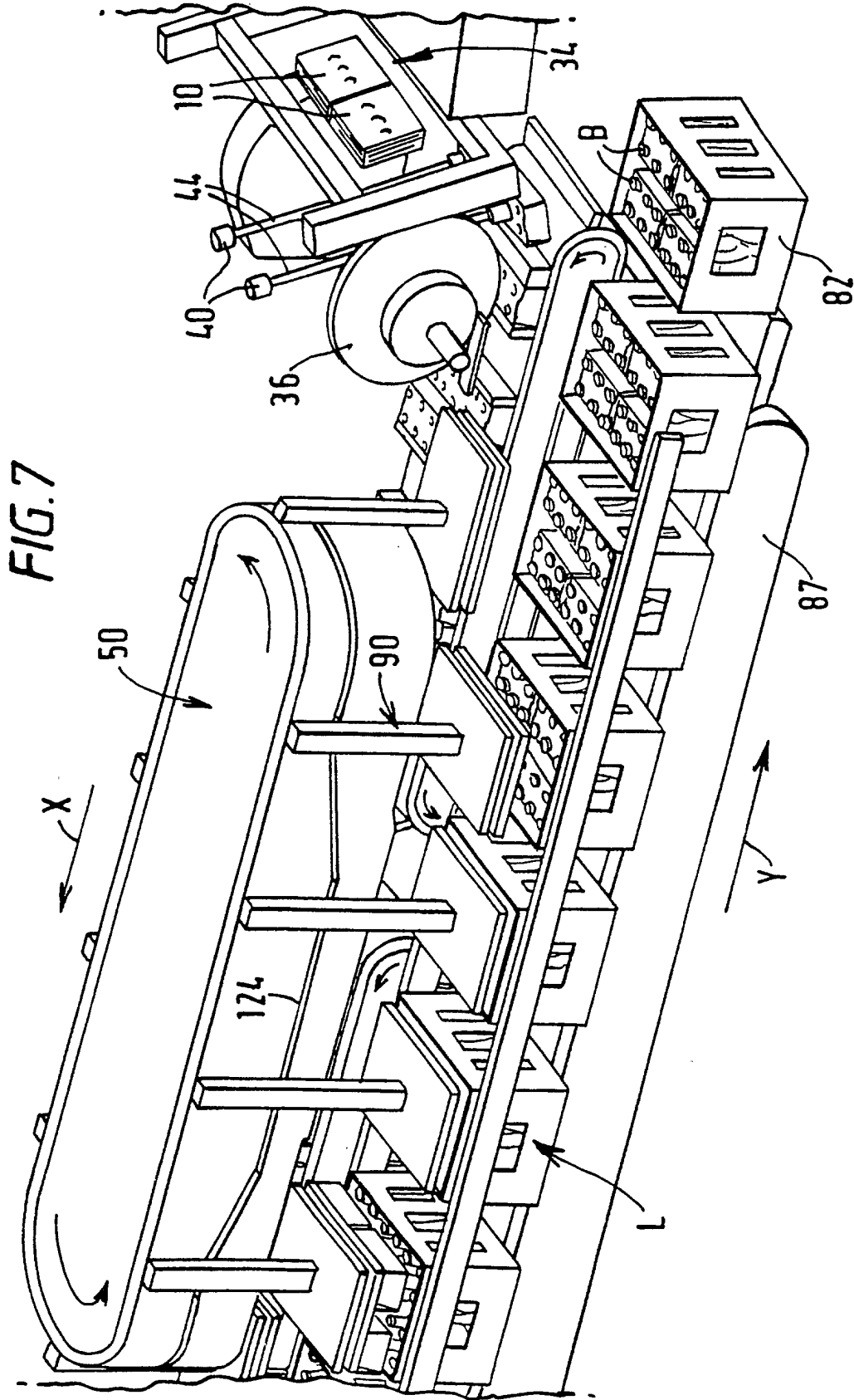
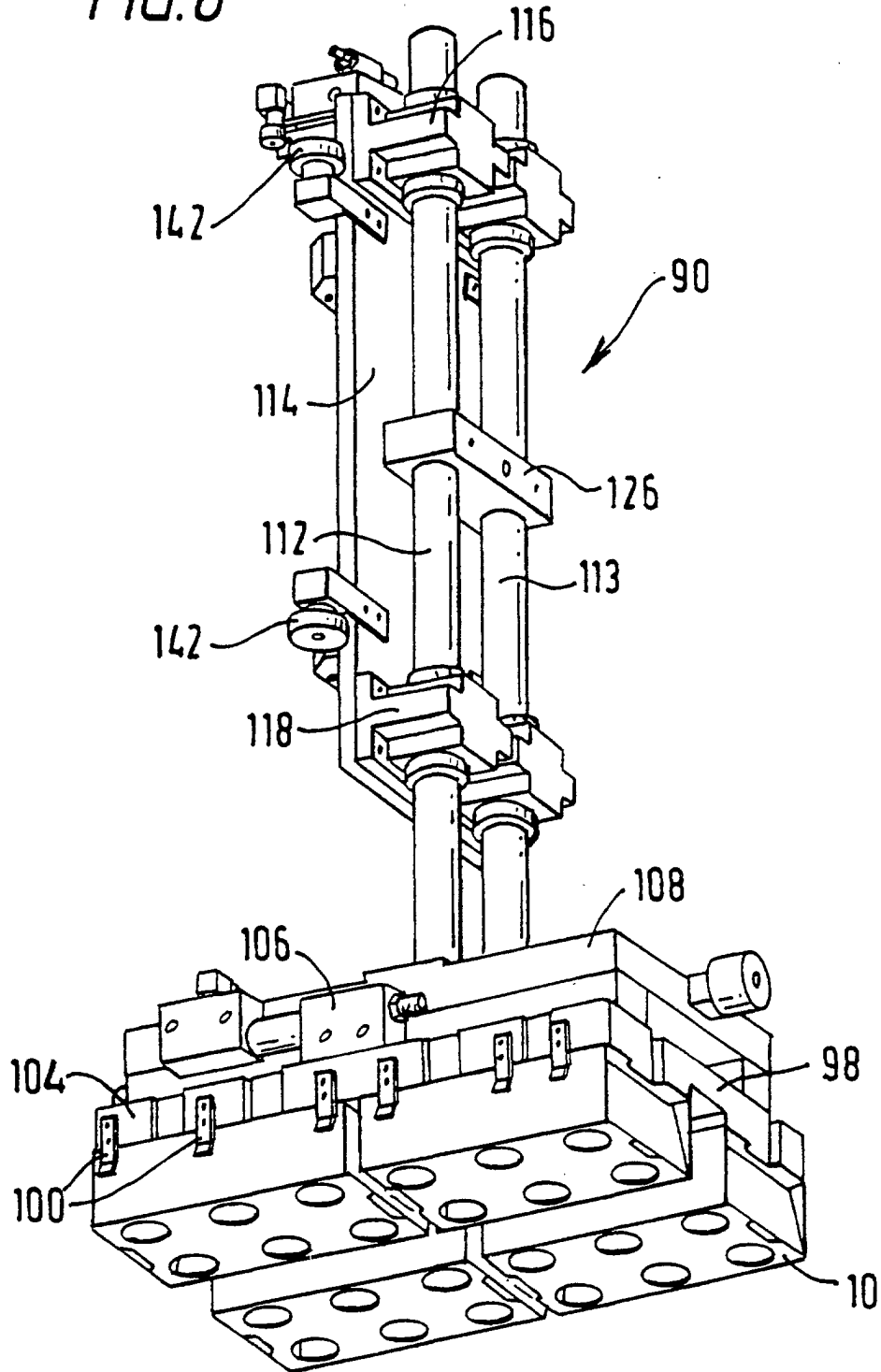

FIG. 8



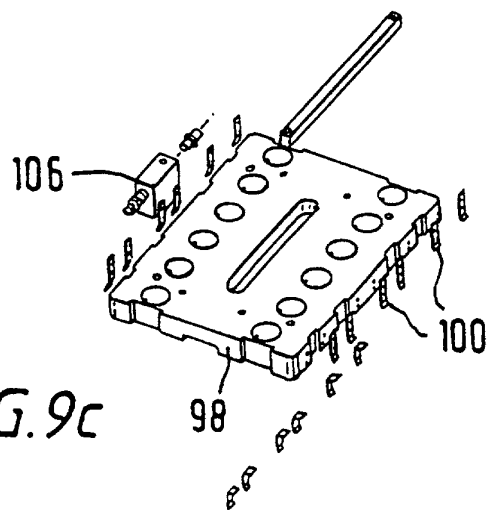
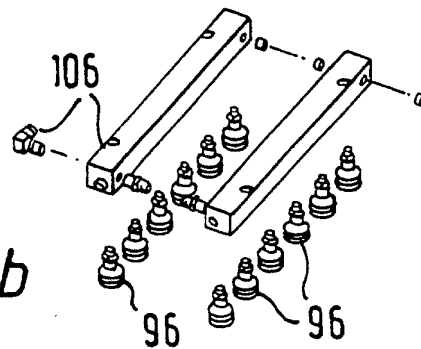
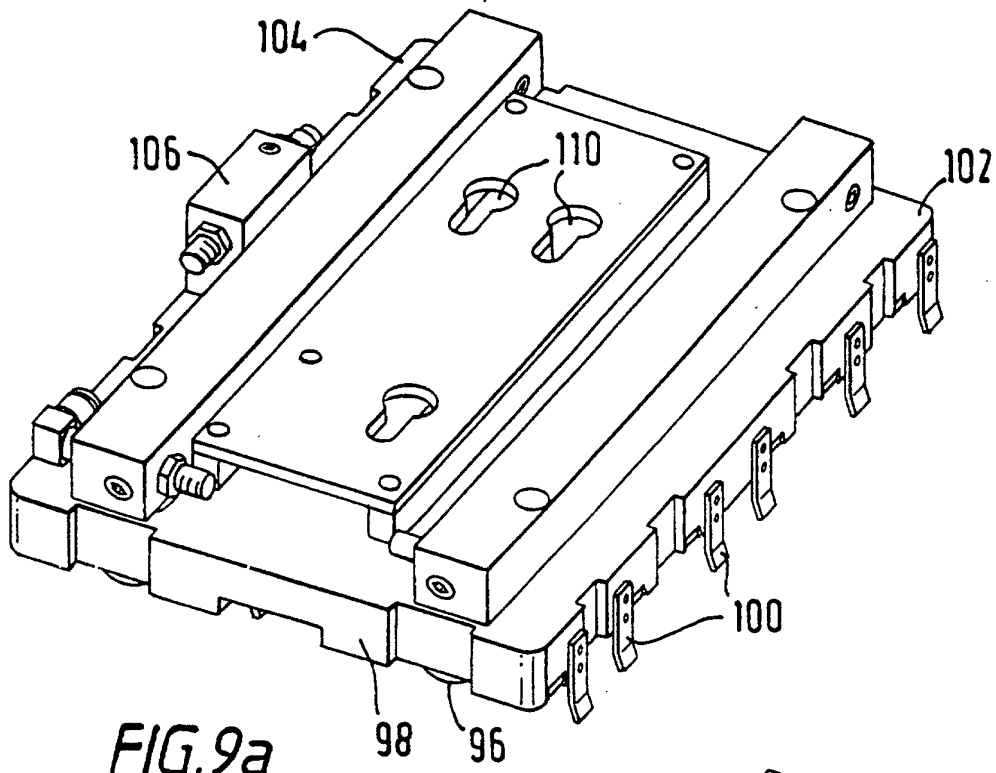

FIG. 11

