

O. G. EDMOND.
LATHE.

(Application filed Nov. 30, 1901.)

(No Model.)

5 Sheets—Sheet 1.

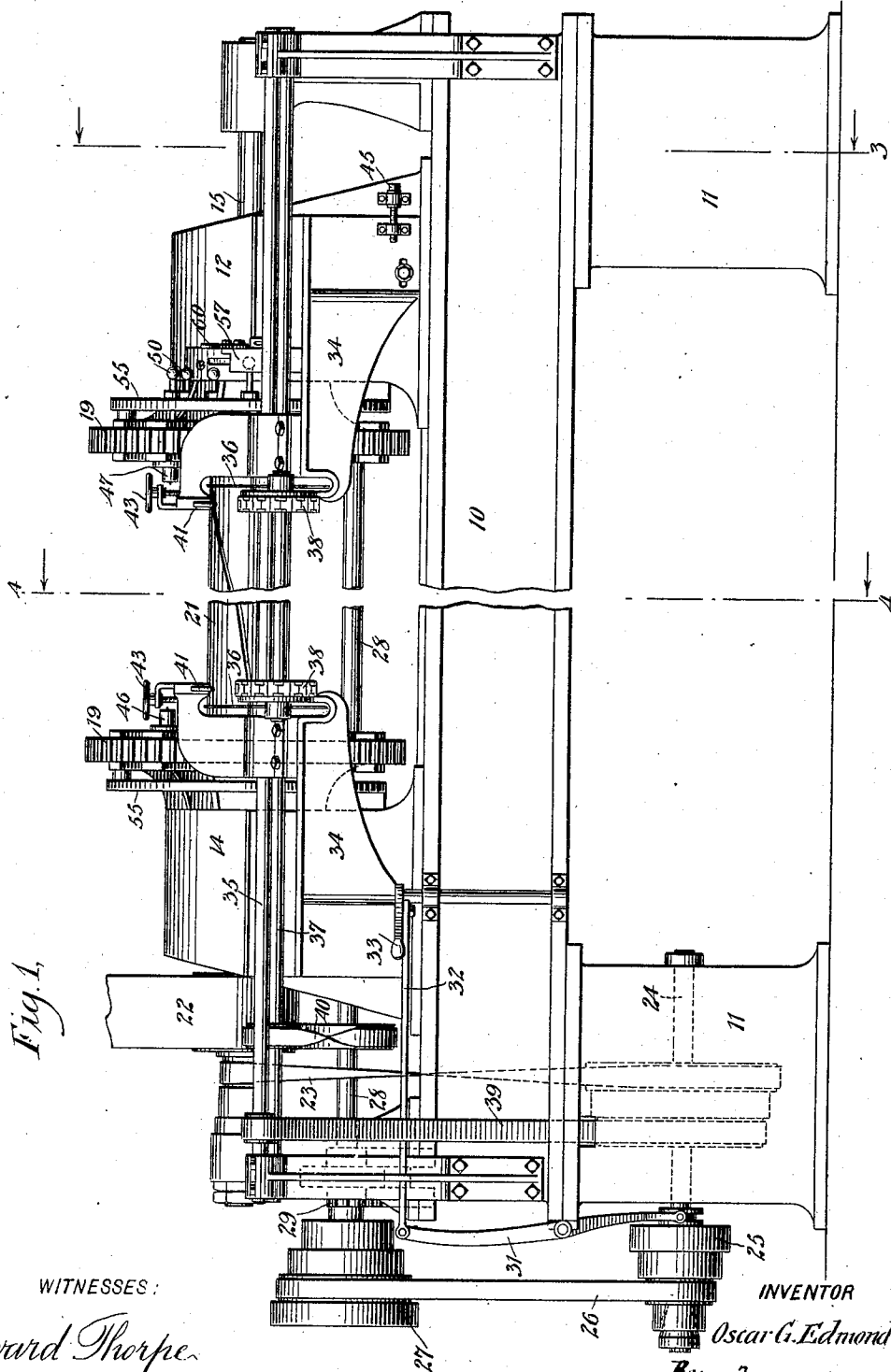

Fig. 1.

WITNESSES:

Edward Thorpe
J. B. Owens

INVENTOR

Oscar G. Edmond

By *[Signature]*
ATTORNEYS

O. G. EDMOND.
LATHE.

(Application filed Nov. 30, 1901.)

(No Model.)

5 Sheets—Sheet 2.

Fig. 2.

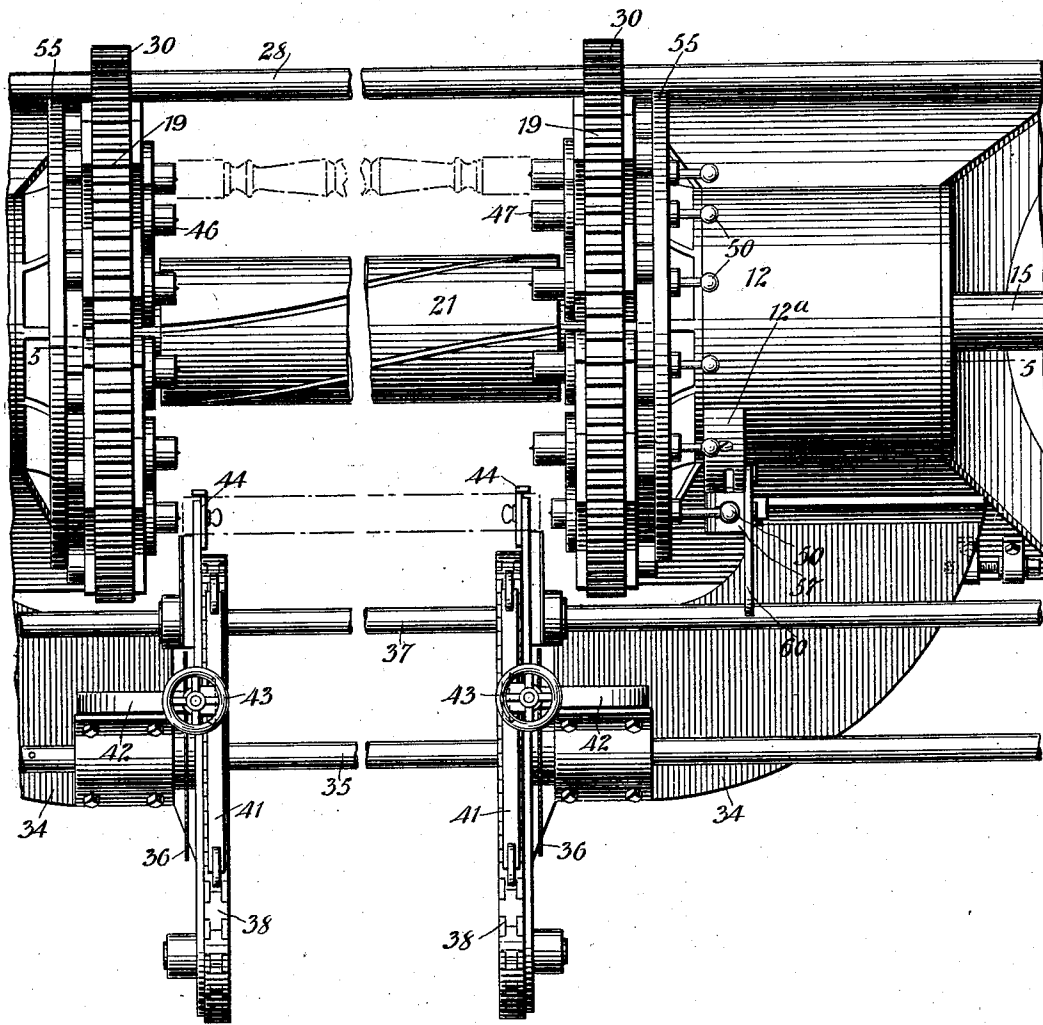

WITNESSES:

Edward Thorpe
J. B. Owens

INVENTOR

Oscar G. Edmond
BY

M. W. [Signature]
ATTORNEYS

No. 712,277.

Patented Oct. 28, 1902.

O. G. EDMOND.
LATHE.

(Application filed Nov. 30, 1901.)

(No Model.)

5 Sheets—Sheet 3.

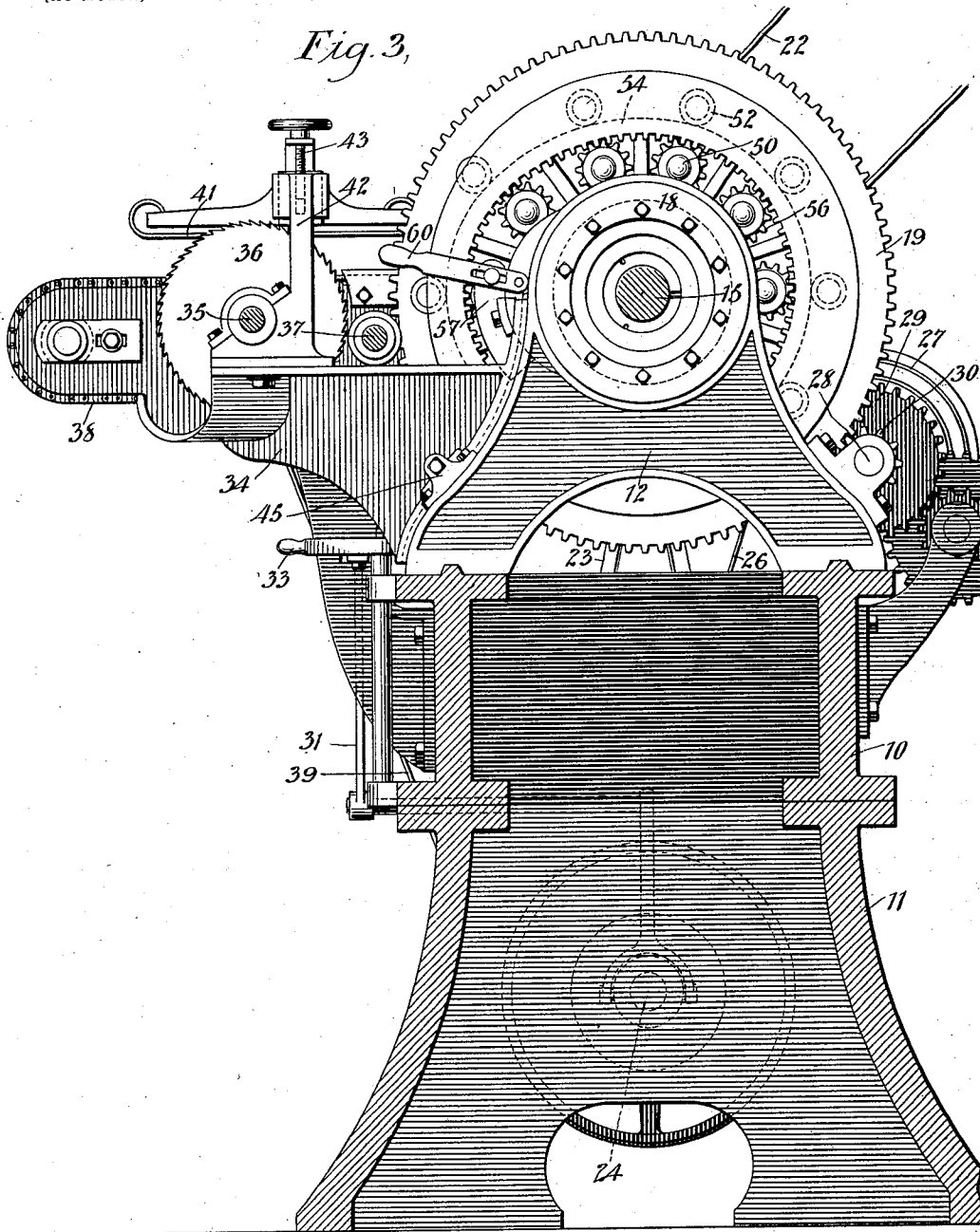

WITNESSES:

Edward Thorpe
J. B. Owens

INVENTOR

Oscar G. Edmond
BY

Wm. W. [Signature]
ATTORNEYS

O. G. EDMOND.
LATHE.

(Application filed Nov. 30, 1901.)

(No Model.)

5 Sheets—Sheet 4.

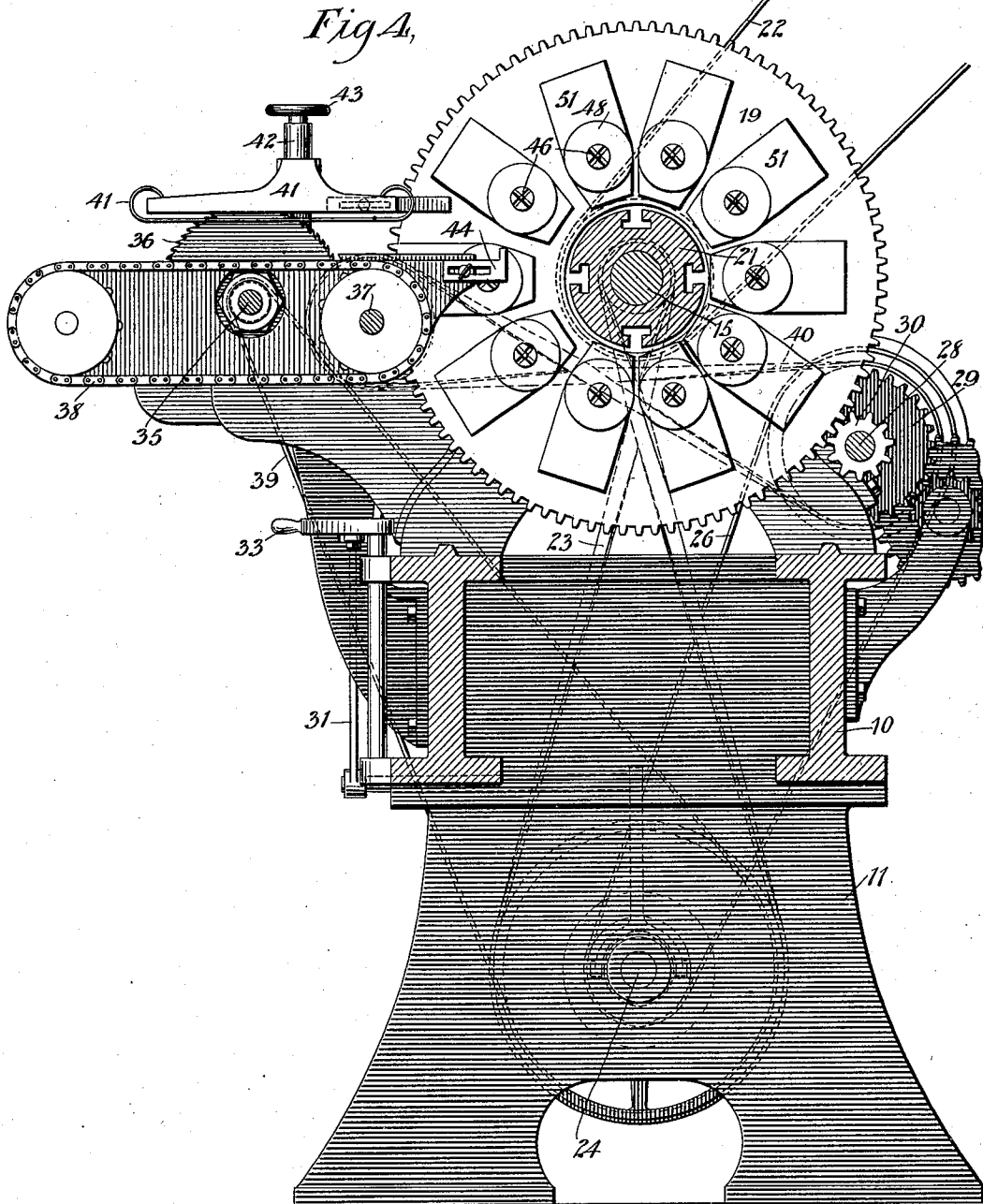

WITNESSES:

Edward Thorpe
J. B. Owens.

INVENTOR

Oscar G. Edmond

BY *[Signature]*

ATTORNEYS

O. G. EDMOND.
LATHE.

(Application filed Nov. 30, 1901.)

(No Model.)

5 Sheets—Sheet 5.

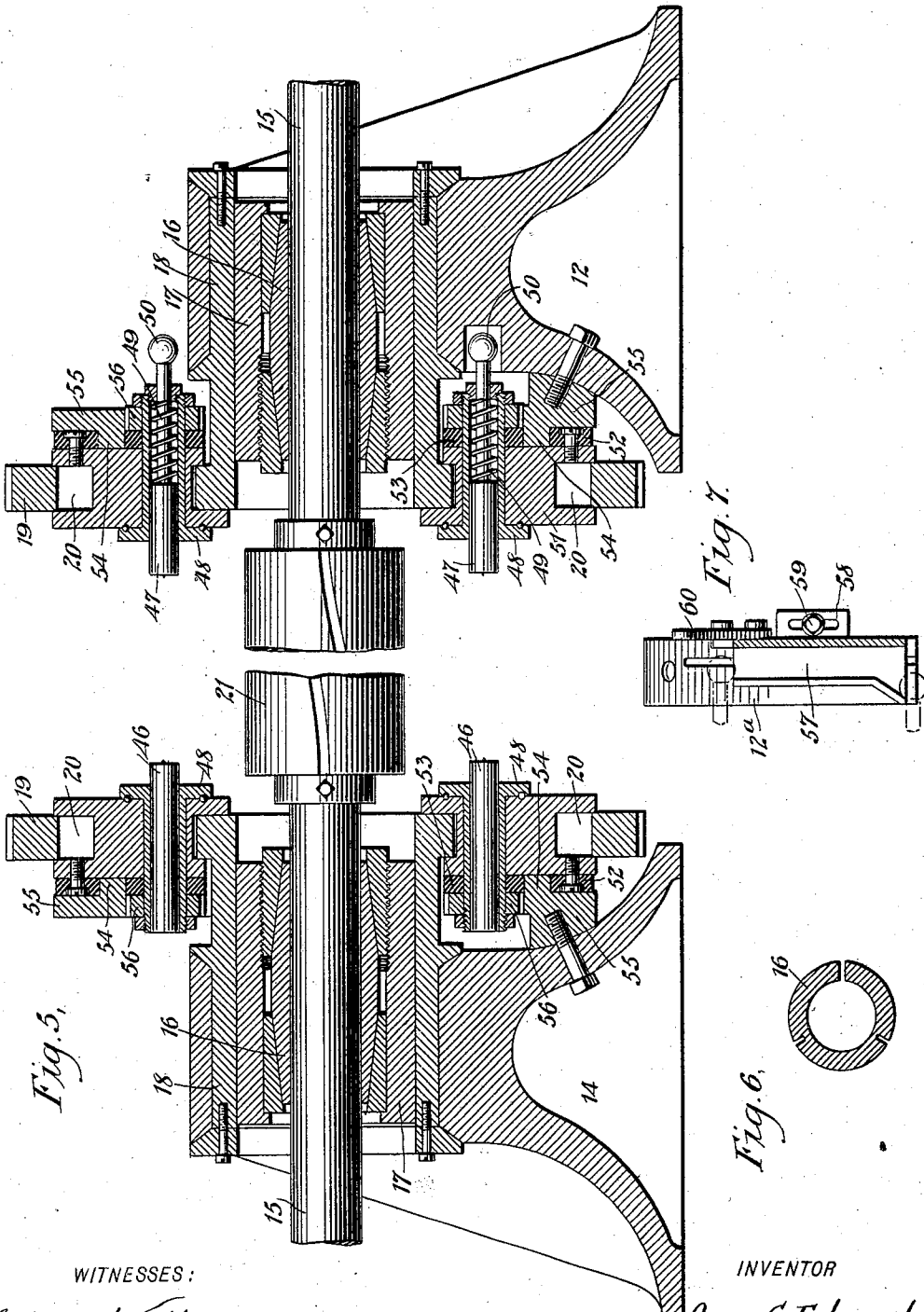

WITNESSES:
Edward Thorpe
J. B. Owens

INVENTOR
Oscar G. Edmond
 BY *Munn*
 ATTORNEYS

UNITED STATES PATENT OFFICE.

OSCAR G. EDMOND, OF WAUSAU, WISCONSIN.

LATHE.

SPECIFICATION forming part of Letters Patent No. 712,277, dated October 28, 1902.

Application filed November 30, 1901. Serial No. 84,168. (No model.)

To all whom it may concern:

Be it known that I, OSCAR G. EDMOND, a citizen of the United States, and a resident of Wausau, in the county of Marathon and State of Wisconsin, have invented a new and improved Lathe, of which the following is a full, clear, and exact description.

This invention relates to an automatic lathe for turning spindles, balusters, handles, and like articles; and it comprises means for feeding the work and cutting it off at even lengths, after which the work passes to work-carriers which move arbitrarily and at the same time turn independently around a cutter, which is of the rotary type.

This specification is a specific description of one form of the invention, while the claims are definitions of the actual scope thereof.

Reference is to be had to the accompanying drawings, forming a part of this specification, in which similar characters of reference indicate corresponding parts in all the views.

Figure 1 is a side elevation of the invention. Fig. 2 is a fragmentary plan view thereof. Fig. 3 is a sectional elevation on the line 3 3 of Fig. 1. Fig. 4 is a cross-section on the line 4 4 of Fig. 1. Fig. 5 is a longitudinal section of the machine on the line 5 5 of Fig. 2. Fig. 6 is a detail section of one of the bearing-bushings, and Fig. 7 is a detail view of the cam-guide for releasing the work.

As shown best in Fig. 1, the lathe has a bed 10, supported at its ends on pedestals 11. On this bed are mounted the head-bearings 12 and 14. In these head-bearings 12 and 14 is mounted the main shaft 15 of the lathe, which is carried loosely in bushings 16, split as indicated in Fig. 6. These bushings 16 are held in boxes 17, in turn carried in sleeves 18, which turn freely in the head blocks or bearings 12 and 14. The sleeves 18 have disk-like heads 19 formed on their inner ends, such heads being peripherally toothed, as will be hereinafter fully described, and radially slotted, as indicated at 20, so as to carry the work-holders, which will be hereinafter described. The shaft 15, at a point between the heads 19, carries the cutter-head 21, to which suitable knives are fastened, as will be fully understood by persons skilled in the art.

The shaft 15 is driven at a high speed by a belt or other movement-transmitting device

22, running around a pulley on the shaft. From this shaft 15 passes a belt 23, transmitting movement to a counter-shaft 24, located in one of the pedestals 11. (See Figs. 1 and 4.) On the shaft 24 is a clutch-pulley 25, serving to drive a belt 26, running to a cone-pulley 27, loose on the shaft 28, which drives the heads of the machine. Movement is imparted to the shaft 28 at a reduced speed from the pulley 27 through the medium of trains of gears. (Indicated by dotted lines at 29 in Fig. 1 and by full lines in Fig. 4.) Fastened to the shaft 28 are pinions 30, (see Figs. 3 and 4,) and these pinions are meshed, respectively, with the heads 19 at their periphery, so as to impart a continuous rotary movement thereto, such movement being, however, very much reduced with respect to that of the shaft 15. The clutch-pulley 25 is operated by means of a lever 31, connected by a rod 32 to a hand-lever 33, located at the side of the machine in position for convenient operation.

34 indicates two brackets which are fastened to the front of the machine, as best indicated in Figs. 1 and 2. These brackets carry revolubly the shaft 35 of the saws 36 and the shaft 37 of the work-conveyer 38. The shaft 35 is driven by a belt 39 from the shaft 24, and the shaft 37 is driven by a belt 40 from the shaft 28. The saws 36 are of the rotary type and serve to cut off the ends of the stock as it passes into the lathe, such operation being indicated by the lower dotted lines in Fig. 2. The carriers 38 for taking the work past the saws into the lathe are mounted on sprocket-wheels carried by the shaft 37 at the inner ends of the carriers and by extensions of the brackets 34 at the outer ends of the carriers.

41 indicates feed-guides under which the work is moved by the carriers and by which the work is held firmly during the sawing operation, these feed-guides 41 being sustained on arms 42, projecting up from the brackets 34 and being adjustable by hand-screws 43. Located at the inner extremities of the carriers 38 are stops 44, (best shown in Fig. 4,) such stops having the work pressed against them by the carriers and holding the work until it is engaged and lifted by the work-holders, to be hereinafter described. One of the brackets 34 may be adjustably mounted,

so that the brackets may be relatively adjusted to suit the length of the work. This is indicated at the right-hand end of Fig. 1, where a screw 45 is shown for facilitating the adjustment.

The work-holders comprise axially-immovable center pins 46 and axially-movable pins 47, arranged in pairs, so as to engage the ends of the work and hold it in longitudinal alinement with the pins. Each pin is carried in a sleeve 48, and in order to render the pins 47 axially movable springs 49 are provided, these springs being located in the sleeves 48 and bearing against the pins. The pins 47 have headed shanks 50 attached thereto and projecting outward beyond the sleeves. All of the axially-movable pins 47 are arranged in one of the heads 19, and the axially-immovable pins are arranged in the other head, the axially-movable pins being provided to permit of engaging and disengaging the work. Each sleeve 48 is carried in a block 51, these blocks being fitted to move radially in the orifices 20 of the heads 19 and having rollers or like guide devices 52 and 53, which rollers run on eccentric tongues 54, formed on guide-rings 55, bolted, respectively, to the head-bearings 12 and 14. These tongues 54 being eccentric to the shaft 15, as the heads 19 turn eccentrically around this shaft independent radial movement will be imparted to the blocks 51, and this will move the pins 46 and 47 laterally toward and from the shaft 15 in addition to their circular movement. The sleeves 48 are revolubly fitted in the blocks 51 and are, with the pins 46 and 47, given a rotary movement independently of the circular movement of the pins. This rotary movement is effected by means of pinions 56, fastened on the sleeves and meshed with internal gears on the rings 55. The springs 49 press the axially-movable pins 47 into engagement with the work, so that normally these pins are active. The pins are moved backward into inactive position by means of a cam-guide 57, which is located at the front side of the machine on the head-bearing 12, just below the point at which the work is fed to the work-holders. This cam-guide is in the form of a grooved slot, and it is adjustably mounted by means of a slotted lug 58 on the guide 57 and a set-screw 59 fitted in the slot.

60 indicates a hand-lever connected with the guide and with the head-bearing to facilitate the adjustment of the guide, so that the backward movement may be imparted to the axially-movable pins at exactly the period desired. The guide 57 is attached to a shoe or extension 12^a of the head-bearing 12, this shoe serving to place the guide in proper line with the path of the work-holding pins, it being understood that the eccentric rib or tongue 54 is removed from the shaft 15 at this point, so as to disengage the work from the cutters on the head 21. The guide 57 is not only cam-shaped, as indicated best in Fig. 7,

but it is also curved in accordance with the curve of the rib or tongue 54, this formation being necessary so as to insure that the stems 50 of the work-holding pins 47 will move true through the guide 57.

In the operation of the machine the knives of suitable form are placed on the cutter-head 21 in such position as to produce the desired pattern on the work—for example, the pattern indicated by dotted lines in the upper part of Fig. 2. I have not described the special form of the knives or other arrangement, since this is not necessarily a part of my present invention. The work in rough form is placed on the carriers 38, parallel with the shaft 15 and extending from one carrier to the other. These carriers advance the work under the guides 41 and then the saws 36 act on the ends of the work to cut it off into equal lengths. The work passes onto the stops 44, against which it is held by the steady pressure behind it. The heads 19 revolving slowly approach a certain pair of the holding-pins 46 and 47 to the work. The guide 57 is so arranged that the instant this certain pin 47 gets in longitudinal alinement with the work the stem of this pin is released and the spring 49 asserts itself, causing the pin to press against the work and hold it firmly between this pin and its companion axially-immovable pin. The work being thus grasped it is carried from the stops 44 around with the steadily-rotating heads. The work is not only moved circularly around the cutter-head 22, but it is also given a slow independent rotary movement. The form of the guide tongue or rib 54 now causes the work-holders to be moved inward toward the cutter-head, and finally the knives begin to act on the work. This operation goes on until the work reaches the front side of the machine just under the feeding devices, whereupon the work of the knives will be finished, and the stem 50 of the pin 47, above referred to, then runs into the guide 57. This retracts the pin, and the work is dropped, whereupon the pin moves on and out of the guide to engage another piece of work.

The above description traces the operation of one pair of work-holding pins. It is obvious that during this time all of the other work-holding pins are in operation in their proper sequence.

Various changes in the form and details of my invention may be resorted to at will without departing from the spirit of my invention. Hence I consider myself entitled to all forms of the invention as may lie within the intent of my claims.

Having thus described my invention, I claim as new and desire to secure by Letters Patent—

1. The combination of a rotary head, a block radially movable thereon, a work-holder revolubly mounted in the block and provided with a gear at one end, an eccentric guide engaged by the block and moving said block ra-

dially in and out, and an eccentric internal gear on the guide and with which the gear on the work-holder meshes, as set forth.

2. The combination of a rotary head, provided with radial slots, blocks mounted to slide in the slots of the head, sleeves mounted to turn in the blocks and each provided with a gear at one end, work-holding pins mounted in the sleeves, an eccentric guide with which the blocks engage and by means of which the blocks are moved in and out in the slots of the head, and an eccentric internal gear with which the gears of the sleeves mesh, as set forth.

3. The combination of a head-bearing, a head arranged to turn thereon, a block arranged to move radially in the head, a work-holding device mounted to turn in the block, an eccentric guide fastened to the head-bearing and engaged by the block to move it radially in the head, said guide having a gear formed thereon, and a gear connected to the work-holder and meshed with the gear of the guide to rotate the work-holder independently of the head.

4. The combination of a head-bearing, a head arranged to turn therein, a block mounted to move radially in the head, a tube fitted to turn in the block, a work-holding pin or center carried in the tube, an eccentric guide fastened to the bearing and engaged by parts on the block, to move it radially of the head, and a gear fastened to the tube, said gear being in mesh with teeth formed on the guide.

5. The combination with a rotary head, a block mounted to slide radially thereon, a sleeve mounted to turn in the block and provided with a gear at one end, an eccentric guide with which the block engages and by means of which the block is moved radially in and out, an eccentric internal gear with which the gear of the sleeve meshes, a sliding and spring-pressed work-holding pin mounted in the sleeve and provided with a reduced end projecting out through the sleeve and having a head thereon, and an adjustable cam-guide curved in the path of the movement of the work-holding pin and with which the head of the said pin engages, as set forth.

6. In a lathe, the combination with a revoluble cutter-head, of radially-slotted heads

mounted to turn at the ends of the cutter-head, blocks radially movable in the slots of said heads, work-holding devices mounted to turn in the blocks and each provided with a gear-wheel at one end, guides eccentric to the bearings of the heads and with which the blocks engage to move them in and out in the slots of said heads, and an eccentric and stationary internal gear carried by each guide, said gears meshing with the gear-wheels of the work-holding devices, as set forth.

7. In a lathe, the combination with a revoluble cutter-head, of a revoluble head at each end of the cutter-head and provided with radial slots, blocks mounted to slide in the slots of said heads, sleeves mounted to turn in the blocks and each provided with a gear-wheel at one end, work-holding pins carried by the blocks, guides eccentric to the bearings of the heads and engaging said blocks to move them back and forth in the slots of the heads, and stationary and eccentric internal gears carried by the guides and meshing with the gear-wheels of the sleeves, as set forth.

8. In a lathe, the combination with a revoluble cutter-head, of a revoluble head at each end of the cutter-head and provided with radial slots, blocks mounted to slide in the said slots, sleeves mounted to turn in the blocks and each provided with a gear-wheel at one end, work-holding pins mounted in the sleeves, the pins carried by the sleeves of one head being axially movable and spring-pressed, while the pins carried by the sleeves of the other head are axially immovable, guides eccentric to the bearings of the heads and with which the blocks engage to move them back and forth in the slots, eccentric and stationary internal gears with which the gears of the sleeves mesh, and a cam-guide curved in the path of movement of the axially-movable pins and with which said pins at predetermined times engage, as set forth.

In testimony whereof I have signed my name to this specification in the presence of two subscribing witnesses.

OSCAR G. EDMOND.

Witnesses:

OTTO W. RINGLE,
HILDA M. RINGLE.