



Europäisches Patentamt
European Patent Office
Office européen des brevets



(11) **EP 0 902 869 B1**

(12) **EUROPEAN PATENT SPECIFICATION**

(45) Date of publication and mention
of the grant of the patent:

13.09.2000 Bulletin 2000/37

(21) Application number: **97923327.7**

(22) Date of filing: **22.05.1997**

(51) Int Cl.7: **F24H 1/48**

(86) International application number:
PCT/NL97/00288

(87) International publication number:
WO 97/45681 (04.12.1997 Gazette 1997/52)

(54) **INTEGRALLY FORMED, COMBINED HEAT EXCHANGER**

INTEGRIERTER KOMBINIERTER WÄRMETAUSCHER

ECHANGEUR DE CHALEUR COMBINE, INCORPORE

(84) Designated Contracting States:
**AT BE CH DE DK ES FI FR GB GR IE IT LI LU MC
NL PT SE**

(30) Priority: **28.05.1996 NL 1003215**

(43) Date of publication of application:
24.03.1999 Bulletin 1999/12

(73) Proprietors:
• **APPARATENFABRIEK WARMTEBOUW B.V.**
5741 HB Beek en Donk (NL)
• **UNICAL AG S.p.A.**
46033 Castel d'Ario (Mantova) (IT)

(72) Inventors:
• **MEGENS, Marinus, Antonius**
NL-5463 AW Veghel (NL)
• **JAHIER, Giovanni**
I-46100 Mantova (IT)

(74) Representative: **Eveleens Maarse, Pieter**
Arnold & Siedsma,
Advocaten en Octrooigemachtigden,
Sweelinckplein 1
2517 GK Den Haag (NL)

(56) References cited:
WO-A-93/12389 **DE-U- 8 530 184**
NL-A- 9 202 045

EP 0 902 869 B1

Note: Within nine months from the publication of the mention of the grant of the European patent, any person may give notice to the European Patent Office of opposition to the European patent granted. Notice of opposition shall be filed in a written reasoned statement. It shall not be deemed to have been filed until the opposition fee has been paid. (Art. 99(1) European Patent Convention).

Description

[0001] The present invention relates to a combined heat exchanger for heating tap water and central heating water by means of hot gases, comprising tap water ducts and central heating water ducts.

[0002] Such combined heat exchangers are generally known, this in the form of heat exchangers manufactured from copper pipes. There are herein always two separate pipes, wherein one of the pipes forms a duct for tap water and the other pipe forms the duct for central heating water.

[0003] It is further pointed out that it is generally known to apply heat exchangers in so-called combination boilers for the combined heating of tap water and central heating water, which heat exchangers are only suitable for heating central heating water, wherein the tap water is heated by a second heat exchanger. It is noted that tap water is also designated as sanitary water.

[0004] Although such combined heat exchangers function well, they have the drawback that a rather high flue gas temperature is required. This is associated with the fact that a relatively high final temperature in the order of magnitude of 70°C is required for tap water, while two heat exchangers must moreover be passed through, each involving an individual temperature loss. Through use of a single heat exchanger which heats the central heating water as well as the tap water, a second heat exchanger for heating the tap water is avoided. This has the advantage that operation can take place at lower flue gas temperatures during take-off of tap water, so that the efficiency of the boiler for sanitary use can be increased.

[0005] From NL-A-9202045 a combined heat exchanger for heating tap water and central heating water by means of hot gases, comprising tap water ducts and central heating water ducts, by which the tap water ducts and the central heating water ducts are incorporated in a single heat exchanger body is known.

[0006] According to said prior art the central heating water ducts are arranged in a first plane and the tap water ducts are arranged in a second plane, located further from the ducts for the flue gases. The transfer of heat to the tap water ducts is thus not optimal, the more as the tap water ducts comprise a separate pipe embedded in the body of the heat exchanger.

[0007] The aim of the invention is the avoiding of those problems.

[0008] This aim is reached in that the tap water ducts and the central heating water ducts are arranged alternately at least in a first part of the heat exchanger body. This leads to a more effective transfer of heat.

[0009] According to a preferred embodiment the heat exchanger body is manufactured from aluminium or an alloy containing aluminium and the tap water ducts are provided with an internal layer.

[0010] The use of aluminium enables a further de-

crease in the flue gas temperatures; possible condensation moisture formed when the dew point is reached does not adversely affect the aluminium.

[0011] Ducts for tap water may not come into contact with aluminium, this being prevented by applying the internal layer, which is manufactured for instance from Teflon.

[0012] Other attractive preferred embodiments are specified in the remaining sub-claims.

[0013] The invention will be further elucidated with reference to the annexed drawings, in which:

figure 1 shows a partly broken away perspective view of a first embodiment of the heat exchanger according to the invention;

figure 2 shows a sectional view of a second embodiment of a heat exchanger according to the invention;

figure 3 shows a sectional view of a third embodiment of a heat exchanger according to the invention; and

figure 4 is a diagram explaining a fourth embodiment of the present invention.

[0014] Shown in figure 1 is a heat exchanger which is designated as a whole with 1. Such a heat exchanger is for instance used in a so-called combination boiler for combined heating of central heating water and tap water.

[0015] The heat exchanger 1 comprises a heat exchanger body 2 for instance cast from aluminium and a burner which is designated with 3. The burner 3 is of course provided with various auxiliary provisions, such as pre-mix taps and the like, although since they do not form the subject of the present invention they are not shown in the drawing. The burner 3 is provided with burner openings 4 and the flames and flue gases exiting therefrom are guided along the heat exchanger body 2 by means of a guide plate 5. The flue gases herein move in downward direction. On arrival at the underside the relevant flue gases are guided under the heat exchanger body 2, wherein they are released on the other side of the heat exchanger body 2. Arranged on the underside for this purpose is a basic body 6 to which the heat exchanger body 2 is fixed, as is guide plate 5.

[0016] The construction described thus far corresponds with usual heat exchangers. The heat exchanger body is provided on its side facing the burner 3 with protrusions 7 whereby the heat-transferring surface is enlarged. Protrusions 7 herein take a shortened form at the position of the burner in respect of the temperatures prevailing there. The guide plate is also provided there with an internal covering 8 of heat-resistant material.

[0017] As can be seen in the drawing, ducts 9 for central heating water and ducts 10 for tap water are arranged alternating in the heat exchanger body 2. A possibility is thus hereby provided of simultaneously being able to heat tap water by means of tap water ducts 10

as well as central heating water by means of central heating ducts 9, wherein the prior art drawbacks of applying two heat exchangers connected in cascade and the required high temperature of the flue gases associated therewith are avoided. It is noted here that in order to prevent the tap water coming into contact with the aluminium of which the heat exchanger body 2 is manufactured, the tap water ducts are provided with an internal layer, for instance of Teflon, not shown in the drawings.

[0018] The heat exchanger body 2 is connected to a supply duct 11 for central heating water, in addition to an outlet duct 12 for central heating water and a supply duct 13 for tap water and an outlet duct 14 for tap water. It will be apparent that the ducts 9, 10 extend transversely of the flow direction of heating gases from the burner 3. In order to cause the ducts 9, 10 to reverse direction, U-shaped guide pieces 15 are placed on the heat exchanger body 2; when applying the relevant casting techniques it is possible to cause the relevant changes in direction of the ducts to take place inside the actual casting, wherein the U-shaped pieces 15 are unnecessary.

[0019] In the present embodiment the tap water ducts 10 and the central heating ducts 9 have the same diameter. It is not otherwise essential that this is the case; this depends of course on the relevant dimensioning of the boiler; the configuration will usually be such that the tap water ducts have a slightly smaller diameter than the central heating ducts.

[0020] An example thereof is shown in figure 2. In the embodiment shown in figure 2 the ducts 10 have a smaller dimension than the ducts 9 for heating the central heating water. It is also pointed out here that the surface of the ducts 10 which is directed toward the protrusions 7 from which the heat transfer takes place is smaller than the corresponding surface of central heating ducts 9. This results in a larger part of the heat transferred from the flue gases being supplied to the liquid flowing inside the central heating ducts 9.

[0021] Another embodiment is shown in figure 3, wherein central heating ducts 9 and tap water ducts 10 both have a trapezium-shaped cross-section. However, adjacent trapezium shapes are herein turned relative to each other. This means that the heat-transferring surfaces of both types of duct differ only slightly from each other; the heat-transferring surface to the tap water ducts 10 is only a little smaller than that to the central heating water ducts 9.

[0022] It will be apparent that the dimensioning of the ducts depends on the expected liquid pressure and flow rate. Thus the cross section of the tap water ducts 10 in figure 3 is much smaller however than that of the central heating water ducts 9, so that it is easier to reach a higher temperature in tap water ducts 10. With this geometry it can however be anticipated that on reaching a certain equilibrium temperature in tap water ducts 10 more heat transfer will take place to the liquid in the ducts 9. It will be apparent that it is possible to apply other duct con-

figurations; operation is thus possible for instance with triangular ducts, or with a combination of triangular and trapezoidal. This is a question of general dimensioning.

[0023] Finally, figure 4 shows a diagram of a heat exchanger according to the invention. The zigzag-shaped ducts are here incorporated in the body of the heat exchanger 2. The tap water ducts 10 are designated with dashed lines and the central heating ducts 10 are designated with a full line. At variance with the above shown embodiments, it can be seen here that the heating ducts for heating tap water 10 extend only over a part of the full height of the heat exchanger; this is also a question of dimensioning. In contrast, ducts 9 for heating central heating water do extend over the full height of the heat exchanger.

[0024] This embodiment further differs in that a short-circuit conduit 17 is arranged in the central heating circuit. This short-circuit line 17 extends from the outlet side 12 for central heating water to the supply 11 for central heating water. A pump 18 is arranged in this short-circuit line 17, while a three-way valve 19 is arranged for controlling the water stream flowing through the short-circuit line 17. It is however very well possible that by applying an accurate pump control of pump 18 and the use of a blocking pump 18 the three-way valve becomes unnecessary. This configuration serves for the situation in which the central heating is not in use, for instance in the summer period, and wherein a large quantity of heated tap water is required. In such a situation it is conceivable that boiling of the water present in the central heating pipes 9 occurs, which must be prevented. Use is made for this purpose of the short-circuit line 17 and the pump included therein, with which the water in the central heating circuit can be circulated without heating the room areas.

[0025] The heat thus absorbed in ducts 9 is herein transferred to the tap water in an extra heat exchanger 20, thus obtaining a sufficient effectiveness of the supplied heat.

Claims

1. Combined heat exchanger (1) for heating tap water and central heating water by means of hot gases, comprising tap water ducts (10) and central heating water ducts (9), by which the tap water ducts (10) and the central heating water ducts (9) are incorporated in a single heat exchanger body (2), **characterized in that** the tap water ducts (10) and the central heating water ducts (9) are arranged alternately at least in a first part of the heat exchanger body (2).
2. Heat exchanger (1) as claimed in claim 1, **characterized in that** the heat exchanger body (2) comprises a second part only provided with central heating ducts(9), wherein the second part, as seen in the flow direction of the heating gases, is located

upstream of the first part.

3. Heat exchanger (1) as claimed in claim 1 or 2, **characterized in that** the ducts (9,10) extend substantially transversely of the flow direction of the heating gases. 5
4. Heat exchanger (1) as claimed in claim 1, 2 or 3, **characterized in that** the heat exchanger body (2) is manufactured from aluminium or an alloy containing aluminium and the tap water ducts (10) are provided with an internal layer (16). 10
5. Heat exchanger (1) as claimed in any of the foregoing claims, **characterized in that** the tap water ducts (10) have a smaller diameter than the central heating water ducts (9). 15
6. Heat exchanger (1) as claimed in any of the foregoing claims, **characterized in that** the tap water ducts (10) each have a smaller heating surface than the central heating water ducts (9). 20
7. Heat exchanger (1) as claimed in claim 6, **characterized in that** the ducts (9,10) have a trapezium-shaped section and that the tap water ducts (10) and the central heating water ducts (9) are placed alternately turned relative to each other. 25
8. Heat exchanger (1) as claimed in claim 7, **characterized in that** the tap water ducts (10) are placed with their short sectional side toward the heat wall. 30
9. Heat exchanger (1) as claimed in any of the foregoing claims, **characterized in that** a short-circuit line (17) for the central heating water ducts (9) is arranged which is connected to the heat exchanger (1) by at least one three-way valve (19), and that a pump (18) is arranged therein. 35
10. Heat exchanger as claimed in claim 9, **characterized in that** the pump (18) is activated by a threshold temperature of the central heating water being exceeded. 40
11. Heat exchanger (1) as claimed in claim 9, **characterized in that** the pump (18) is activated by switching on the heat source (3) for the heating gases. 45
12. Heat exchanger (1) as claimed in any of the foregoing claims, **characterized in that** an extra heat exchanger (20) heated by the central heating circuit (12) is incorporated in the tap water circuit. 50
13. Boiler for combined heating of central heating water and tap water, **characterized by** a heat exchanger (1) as claimed in any of the foregoing claims. 55

Patentansprüche

1. Kombiniertes Wärmetauscher (1) zum Erwärmen von Brauchwasser und Zentralheizungswasser mittels heißer Gase, mit Brauchwasserleitungen (10) und Heizungswasserleitungen (9), wobei die Brauchwasserleitungen (10) und die Heizungswasserleitungen (9) in ein einziges Wärmetauschergehäuse (2) eingebaut sind, dadurch **gekennzeichnet**, daß die Brauchwasserleitung (10) und die Heizungswasserleitung (9) miteinander abwechselnd mindestens in einem ersten Teil des Wärmetauschergehäuses (2) angeordnet sind.
2. Wärmetauscher (1) nach Anspruch 1, dadurch **gekennzeichnet**, daß das Wärmetauschergehäuse (2) einen zweiten Teil aufweist, der nur mit Heizungswasserleitungen (9) versehen ist, wobei der zweite Teil in der Strömungsrichtung der Heizgase gesehen stromaufwärts von dem ersten Teil angeordnet ist.
3. Wärmetauscher (1) nach Anspruch 1 oder 2, dadurch **gekennzeichnet**, daß die Leitungen (9, 10) im wesentlichen quer zur Strömungsrichtung der Heizgase verlaufen.
4. Wärmetauscher (1) nach Anspruch 1, 2 oder 3, dadurch **gekennzeichnet**, daß das Wärmetauschergehäuse (2) aus Aluminium oder einer aluminiumhaltigen Legierung besteht und die Brauchwasserleitungen (10) mit einer inneren Schicht (16) versehen sind.
5. Wärmetauscher (1) nach einem der vorangehenden Ansprüche, dadurch **gekennzeichnet**, daß die Brauchwasserleitungen (10) einen kleineren Durchmesser als die Heizungswasserleitungen (9) haben.
6. Wärmetauscher (1) nach einem der vorangehenden Ansprüche, dadurch **gekennzeichnet**, daß die Brauchwasserleitungen (10) jeweils eine kleinere Heizfläche als die Heizwasserleitungen (9) haben.
7. Wärmetauscher (1) nach Anspruch 6, dadurch **gekennzeichnet**, daß die Leitungen (9, 10) einen trapezförmigen Querschnitt haben und daß die Brauchwasserleitungen (10) und die Heizungswasserleitungen (9) abwechselnd gegeneinander gedreht angeordnet sind.
8. Wärmetauscher (1) nach Anspruch 7, dadurch **gekennzeichnet**, daß die Brauchwasserleitungen (10) mit ihrer kurzen Querschnittsseite der Heizwand zugewendet angeordnet sind.

9. Wärmetauscher (1) nach einem der vorangehenden Ansprüche, dadurch **gekennzeichnet**, daß eine Kurzschlußleitung (17) für die Heizungswasserleitungen (9) vorgesehen ist, die mit dem Wärmetauscher (1) über mindestens ein Dreiwegeventil (9, 10) verbunden ist, und daß darin eine Pumpe (18) angeordnet ist. 5
10. Wärmetauscher nach Anspruch 9, dadurch **gekennzeichnet**, daß die Pumpe (18) bei Überschreiten einer Schwellentemperatur des Zentralheizungswassers aktiviert wird. 10
11. Wärmetauscher (1) nach Anspruch 9, dadurch **gekennzeichnet**, daß die Pumpe (18) beim Anschalten der Wärmequelle (3) für die Heizgase aktiviert wird. 15
12. Wärmetauscher (1) nach einem der vorangehenden Ansprüche, dadurch **gekennzeichnet**, daß ein zusätzlicher Wärmetauscher (20), der von dem Zentralheizkreislauf (12) erwärmt wird, in dem Brauchwasserkreis angeordnet ist. 20
13. Boiler zum gemeinsamen Heizen von Zentralheizungswasser und Brauchwasser, **gekennzeichnet** durch einen Wärmetauscher (1) nach einem der vorangehenden Ansprüche. 25

Revendications

1. Échangeur de chaleur mixte (1) pour chauffer de l'eau du robinet et de l'eau de chauffage central au moyen de gaz chauds, comprenant des conduits (10) d'eau du robinet et des conduits (9) d'eau de chauffage central, dans lequel les conduits (10) d'eau du robinet et les conduits (9) d'eau de chauffage central sont intégrés à un unique corps (2) d'échangeur de chaleur, caractérisé en ce que les conduits (10) d'eau du robinet et les conduits (9) d'eau de chauffage central sont agencés en alternance au moins dans une première partie du corps (2) de l'échangeur de chaleur. 35
2. Échangeur de chaleur (1) selon la revendication 1, caractérisé en ce que le corps (2) de l'échangeur de chaleur comprend une deuxième partie munie seulement de conduits de chauffage central (9), dans lequel la deuxième partie, en regardant dans la direction d'écoulement des gaz de chauffe, est située en amont de la première partie. 40
3. Échangeur de chaleur (1) selon la revendication 1 ou 2, caractérisé en ce que les conduits (9, 10) s'étendent substantiellement transversalement à la direction d'écoulement des gaz de chauffe. 45
4. Échangeur de chaleur (1) selon la revendication 1, 2 ou 3, caractérisé en ce que le corps (2) de l'échangeur de chaleur est fabriqué en aluminium ou dans un alliage contenant de l'aluminium et les conduits d'eau du robinet (10) sont munis d'une couche intérieure (16). 50
5. Échangeur de chaleur (1) selon l'une quelconque des revendications précédentes, caractérisé en ce que les conduits d'eau du robinet (10) ont un diamètre inférieur à celui des conduits (9) d'eau de chauffage central. 55
6. Échangeur de chaleur (1) selon l'une quelconque des revendications précédentes, caractérisé en ce que les conduits d'eau du robinet (10) ont chacun une surface de chauffage plus petite que celle des conduits (9) d'eau de chauffage central. 60
7. Échangeur de chaleur (1) selon la revendication 6, caractérisé en ce que les conduits (9, 10) ont une section trapézoïdale et en ce que les conduits d'eau chaude (10) et les conduits d'eau de chauffage central (9) sont placés en alternance tournés les uns par rapport aux autres. 65
8. Échangeur de chaleur (1) selon la revendication 7, caractérisé en ce que les conduits (10) d'eau du robinet sont placés avec leur petit côté de section en direction de la paroi chauffante. 70
9. Échangeur de chaleur (1) selon l'une quelconque des revendications précédentes, caractérisé en ce qu'un conduit de court-circuit (17) pour les conduits d'eau de chauffage central (9) est prévu, qui est reliée à l'échangeur de chaleur (1) par au moins une vanne trois voies (19), et en ce qu'une pompe (18) y est placée. 75
10. Échangeur de chaleur (1) selon la revendication 9, caractérisé en ce que la pompe (18) est activée par le fait qu'une température de seuil de l'eau de chauffage central est dépassée. 80
11. Échangeur de chaleur (1) selon la revendication 9, caractérisé en ce que la pompe (18) est activée en mettant en fonctionnement la source de chaleur (3) pour les gaz de chauffe. 85
12. Échangeur de chaleur (1) selon l'une quelconque des revendications précédentes, caractérisé en ce qu'un échangeur de chaleur supplémentaire (20) chauffé par le circuit de chauffage central (12) est intégré au circuit d'eau du robinet. 90
13. Chaudière pour le chauffage combiné d'eau de chauffage central et d'eau du robinet, caractérisée par un échangeur de chaleur selon l'une quelcon- 95

que des revendications précédentes.

5

10

15

20

25

30

35

40

45

50

55

6

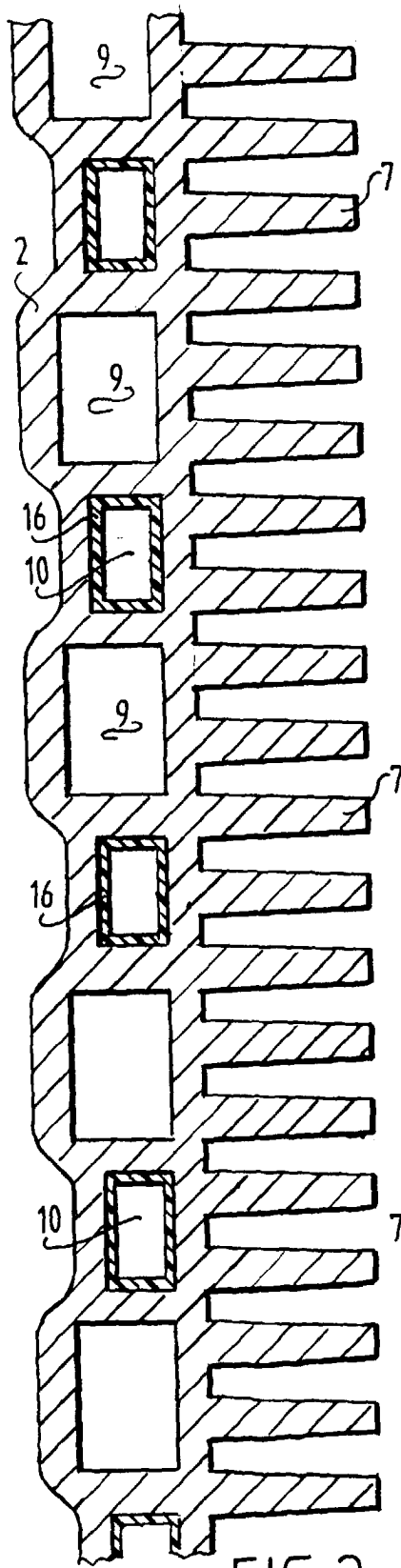

FIG. 2

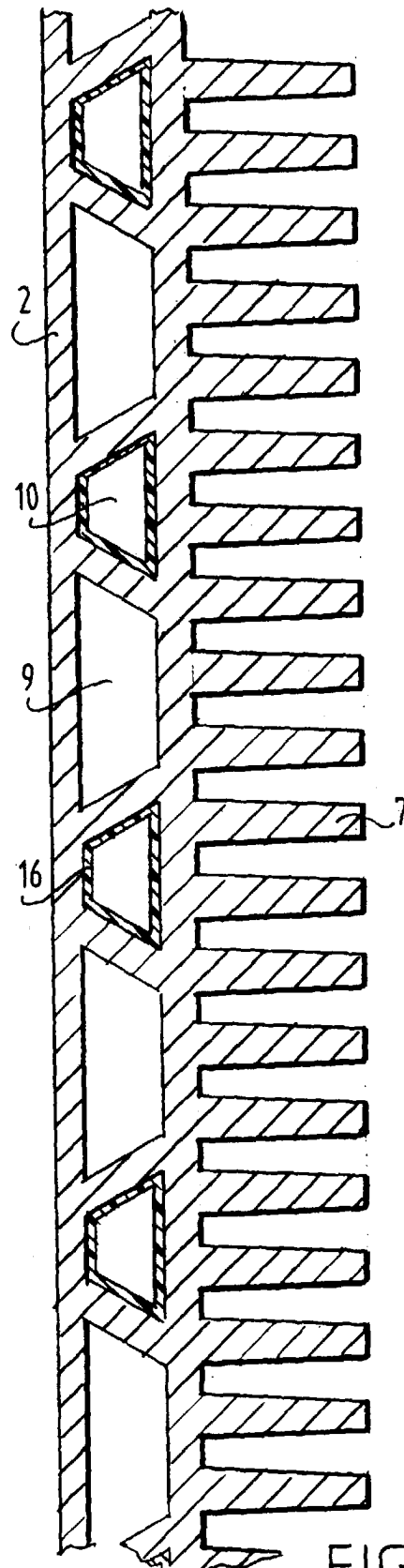

FIG. 3

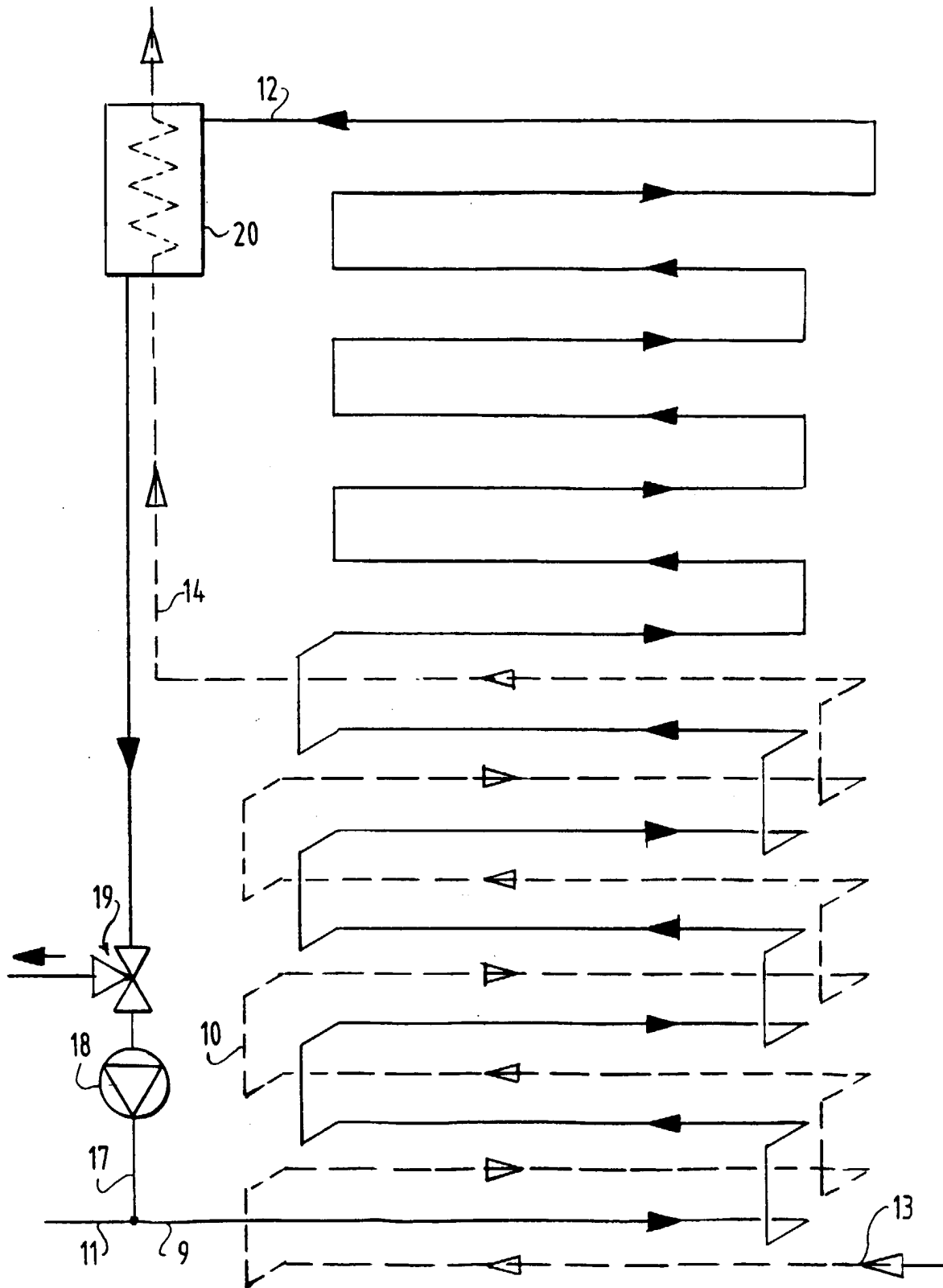

FIG.4