

May 6, 1930.

R. G. CLARK

1,757,793

FEEDER AND SORTER

Filed Dec. 19, 1928

2 Sheets-Sheet 1

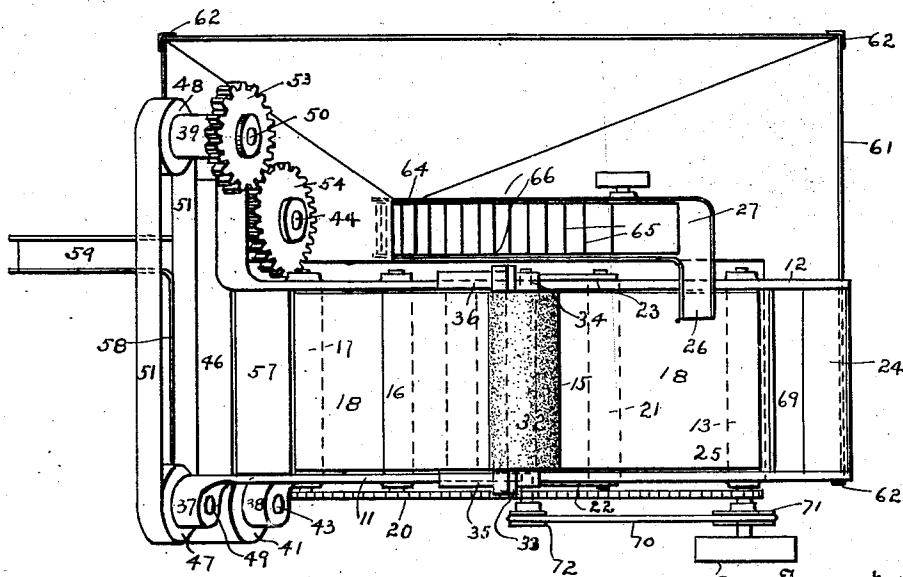
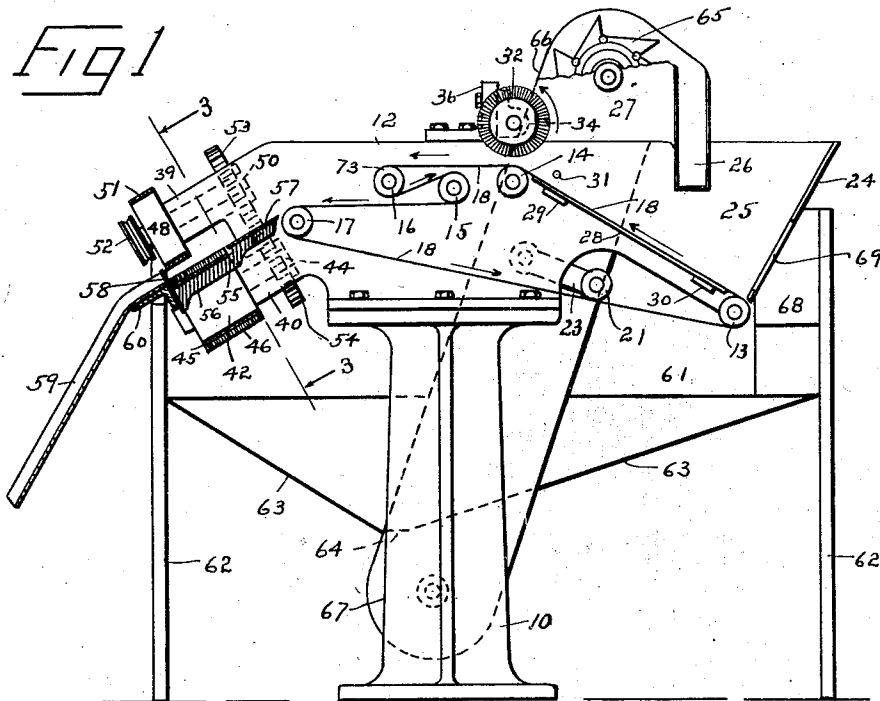

FIG 2

Inventor
Robert G. Clark

By Attorney
Henrik J. Schmidt

May 6, 1930.

R. G. CLARK

1,757,793

FEEDER AND SORTER

Filed Dec. 19, 1928

2 Sheets-Sheet 2

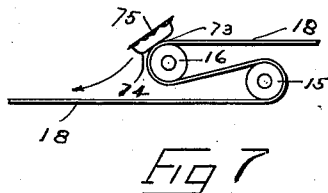
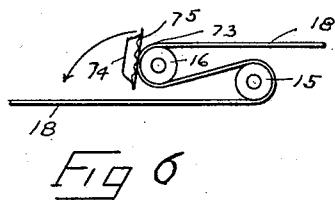
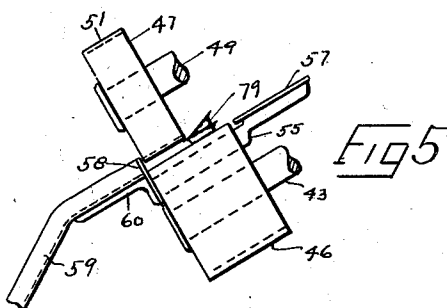
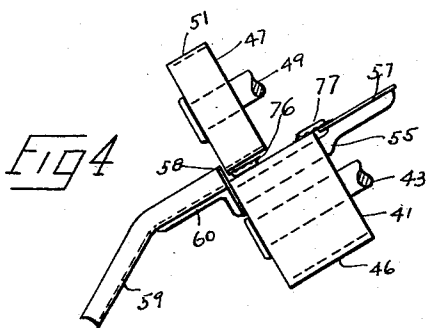
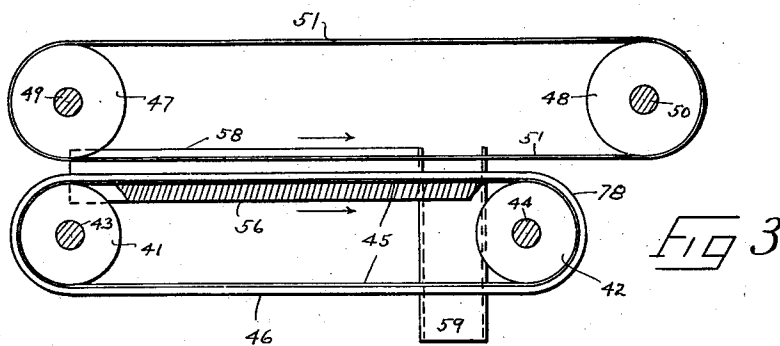

Inventor
Robert G. Clark,
By his Attorney
Henrik J. Schmidt.

UNITED STATES PATENT OFFICE

ROBERT G. CLARK, OF BROOKLYN, NEW YORK

FEEDER AND SORTER

Application filed December 19, 1928. Serial No. 327,149.

My invention relates to feeders and sorters of the belt conveying type. It has for its main object to provide a device which will positively arrange and deliver the articles, on which it is operating, in the correct position and at very high speed.

Another object is to provide a feeding and sorting device which will not scratch, or in any other way mar or disfigure the articles being fed and sorted. A further object is to provide means whereby the articles sorted out are automatically returned for resorting. A still further object is to provide a device of simple but strong construction, thoroughly automatic in all its operations, and comparatively inexpensive to manufacture.

These and other objects and advantages will be readily understood from the following description and from the accompanying drawings of a preferred embodiment, but it will be clearly understood that various modifications may be made without departing from the scope of the invention. In the drawings

Fig. 1 is a side elevation of the preferred embodiment in which certain parts have been removed and others are shown in cross-section,

Fig. 2 is a plan view of Fig. 1,

Fig. 3 is a cross-sectional side elevation of certain parts taken on line 3—3 in Fig. 1,

Figs. 4 and 5 are end views of Fig. 3 and show certain steps in sorting, and

Figs. 6 and 7 are fragmentary side views showing certain other steps in sorting.

Figs. 1 and 2 are drawn to a smaller scale than the rest of the views.

While the embodiment shown and described is particularly designed for feeding and sorting bottle caps, or, as they are commonly called, crown caps, it will be distinctly understood that I do not wish to limit the invention to the feeding and sorting of these caps only, but intend to use it for any articles to which it may be adapted.

Referring first to Figs. 1 and 2, the machine consists of a pedestal 10 on the flat upper surface of which are clamped two side frames 11 and 12. In Fig. 1 the side frame 11 has been removed to expose the interior

parts. The side frames, which are much longer than the top surface of the pedestal and overhang it in the front and rear, are provided with a number of bearings in which rollers 13, 14, 15, 16 and 17 rotate. An endless belt 18 operates on these rollers, as plainly shown in Fig. 1 where the direction of its travel is also indicated by several arrows.

Power for driving the rollers is imparted to the pulley 19 which is attached on the shaft of the roller 13. All the rollers are connected and driven by a chain 20 which engages on sprocket wheels secured on the roller shafts. These parts, while omitted on Fig. 1, are plainly shown on Fig. 2. A belt tightening device, consisting of a roller 21 rotatably mounted in two levers 22 and 23 which are swingably mounted on the outside of the side frames, always keeps the belt under the right tension.

The rear ends of the side frames together with part of the belt 18 and a rear plate 24 form a bin 25 into which the articles to be fed and sorted are poured from the bucket conveyor 27 through the spout 26. The conveyor will be described later. A drag board 28 is located under the belt, as shown, and is secured to lugs 29 and 30 cast on the side frames.

A wire 31 is stretched across the bin 25 a short distance above the belt. A rotary brush 32 is located above the roller 14. It rotates in bearings 33 and 34 which are adjustably secured to the brackets 35 and 36. These brackets are bolted to the top of the side frames. The direction of rotation of the brush is indicated by an arrow.

The front ends of the side frames terminate in bearings 37, 38, 39 and 40. The bearings 37 and 38, which are located on side frame 11, are offset an equal distance sidewardly from the side frame. The bearing 39 is offset a greater distance sidewardly from the side frame 12 than the bearing 40. The bearings 37 and 39 also extend a greater distance outwardly than the bearings 38 and 40. The axes of all these bearings form a downwardly sloping angle with the side frames.

Pulleys 41 and 42 are attached to shafts 43 and 44 which rotate in the bearings 38 and 40.

An endless belt 45 engages on these pulleys. This belt is of a special construction. It consists, preferably, of an ordinary belt to the conveying side of which is stitched or otherwise secured a fabric having a comparatively high pile or nap. I have also successfully used metal wires fastened in a fabric (similar to a card) as well as bristles. This piled fabric is indicated at 46, in Fig. 1.

Pulleys 47 and 48 are attached to shafts 49 and 50 which rotate in the bearings 37 and 39. An ordinary, endless belt 51 engages on these pulleys. This belt is considerable longer and narrower than the belt 45 and is set over even with the outer edge of this belt. All these parts are also shown in Figs. 3, 4 and 5; an examination of these views will make it easier to understand the construction. Both these belts are driven by a pulley 52, attached on shaft 50, and by two equal-sized gears 53 and 54, attached, respectively, on shafts 50 and 44.

A bracket 55 is secured between the side frames and its construction is such that its forward end 56 supports the belt 45, while its rear end supports an apron 57 over which the articles to be fed and sorted slide from the belt 18 to the belt 45. A stop 58 extends along the outer edge of the belt 45 and terminates in a chute 59. The chute is supported by a bracket 60 attached to the forward end 56 of the bracket 55, while the stop 58 is attached directly to the forward end 56. These parts are also shown in Figs. 3, 4 and 5.

A large hopper 61 is provided on one side of the machine. It is supported on legs 62 and its bottom 63 slopes downwardly from all sides so that the articles contained in the hopper will slide towards the loading opening 64 in the bucket conveyor 27. The buckets 65 travel upwardly in a U shaped frame 66 and discharge into the spout 26. The lower end 67 of the conveyor extends below the bottom of the hopper so that the articles will be loaded on the buckets at the point 64. While the main part of the hopper is located at one side of the machine, an extension 68 extends in under the rear plate 24 so as to receive the overflow from the bin 25 as it is discharged through the opening 69.

The rotating brush 32 is driven from the main shaft by a chain 70 which engages with sprocket wheels 71 and 72, attached, respectively on the main shaft and the brush shaft.

The machine operates in the following manner: The crown caps are placed in the hopper 61, from which they are conveyed to the bin 25 by the conveyor 27. If too many caps enter the bin, the surplus is discharged back into the hopper through the opening 69 and extension 68. The belt 18 conveys the caps from the bin 25. As they travel upward with the belt, the wire 31 spreads them in an even layer. If any of the caps are nested one inside another, they are swept back in

the bin by the rotating brush 32. The distance between the brush and the belt is such that only single caps, in one layer, can pass between them. The caps continue with the belt until the point 73 is reached.

Referring now to Figs. 6 and 7, it will be seen that the caps, as they are conveyed from the bin 25, may rest on the belt with either their top 74 or bottom 75 in engagement with the belt. The object in this particular case is to deliver all the caps to the chute 59 with their bottom or open side up. As the caps pass over the point 73, they are almost all deposited on the part of the belt below with their bottom side up. Sorting in this manner is made possible by the particular shape of the cap. If a cap is conveyed "bottom down" on the upper belt, it will, when striking the lower belt, be turned over, due to the location of its center of gravity. This is illustrated in Fig. 6. If a cap is conveyed "top down" on the upper belt, it will continue in this position on the lower belt, as shown in Fig. 7.

As stated, most of the caps are correctly placed by the means just described. At times, particularly if the caps are fed so fast that one may strike another when passing over the point 73, some may be wrong side up. To positively prevent such caps from reaching the chute 59, all the caps are fed across the apron 57 and transversely onto the piled fabric 46 of the belt 45. Referring now to Figs. 3, 4, and 5, it will be seen that any cap delivered in the right position, that is "top down" as at 76, will, owing to the inclined position of the belt 45, slide right across the fabric until retarded by the stop 58; the pile or nap having no effect on the top of the cap. These caps are conveyed by the belt until discharged through the chute 59.

If a cap is delivered to the transverse belt wrong side up, as shown at 77, it is immediately engaged by the nap or pile of the fabric and carried along with the belt until discharged back into the hopper 61 at the point 78 (Fig. 3). If a cap should be delivered to the transverse belt nested within another cap, as shown at 79, both these caps are prevented from crossing the fabric by being retarded by the upper belt 51. The distance between this belt and the fabric being such as to just provide space for a single cap. These nested caps are also carried back to the hopper 61, by the fabric 46, for resorting. It will thus be seen that only caps with the right side up are delivered to the chute 59 and that all others are returned to the hopper for resorting.

Having described my invention and its operation, what I claim as new and wish to protect by Letters Patent is:

1. In a device of the class described, a pair of pulleys having their axes at an angle with the horizontal line, a conveying belt actuated

by said pulleys, the conveying surface of said belt consisting of a fabric having a pile or nap, a stop extending along the lower edge of said belt and terminating in a discharge chute, means for feeding articles onto the upper edge of said belt, and means for actuating said pulleys.

2. In a device of the class described, a pair of pulleys having their axes at an angle with the horizontal line, a conveying belt actuated by said pulleys, the conveying surface of said belt consisting of a fabric having a pile or nap, a stop extending along the lower edge of said belt and terminating in a discharge chute, a narrower belt located a given distance above the first-mentioned belt and also actuated by two pulleys, and means for actuating all of said pulleys.

3. In a device of the class described, a hopper, a bin, a conveyor feeding from said hopper to said bin, a conveying belt traveling through said bin, said conveying belt actuated by a plurality of rollers in such a manner that a discharge point is formed from which articles will drop from one part to another part of the belt so as to place such articles in the correct position on the belt, a pile-surfaced, transverse belt unto which said conveying belt feeds, and means for actuating all of the parts.

4. In a device of the class described, a hopper, a bin, a conveyor feeding from said hopper to said bin, a conveying belt traveling through said bin, said conveying belt actuated by a plurality of rollers in such a manner that a discharge point is formed from which articles will drop from one part to another part of the belt so as to place such articles in the correct position on the belt, a transverse sorting mechanism consisting of a lower pile-surfaced belt and an upper narrower belt into which articles are fed by the conveying belt for final sorting, and means for actuating all of said parts.

5. In a device of the class described, a hopper, a bin, a conveyor feeding from said hopper to said bin, a conveying belt traveling through said bin, said conveying belt actuated by a plurality of rollers in such a manner that a discharge point is formed from which articles will drop from one part to another part of the belt so as to place such articles in the correct position on the belt, a transverse sorting mechanism consisting of a lower pile-surfaced belt and an upper narrower belt into which articles are fed by the conveying belt for final sorting, a chute for returning all wrongly placed articles to the hopper, and means for actuating all the parts.

ROBERT G. CLARK.