

J. B. WOOD.
BRAIDING MACHINE.

No. 41,045.

Patented Dec. 22, 1863.

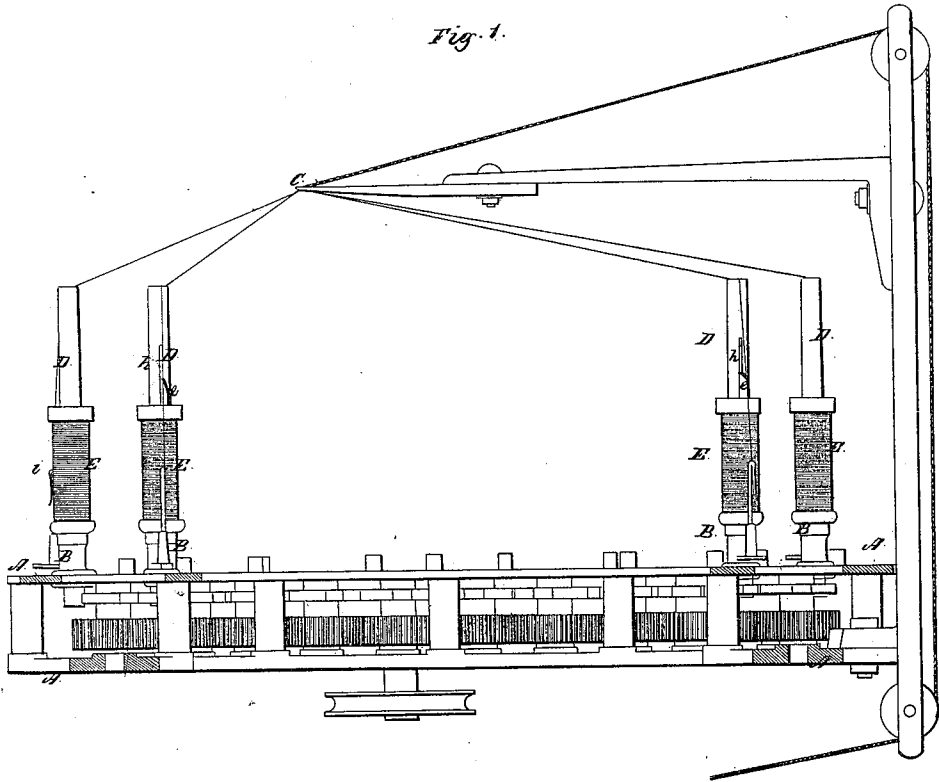

Witnesses:
J. C. Coombs
G. W. Reed

Inventor:
J. B. Wood
per *Mumford*
Attorney.

J. B. WOOD.
BRAIDING MACHINE.

No. 41,045.

Patented Dec. 22, 1863.

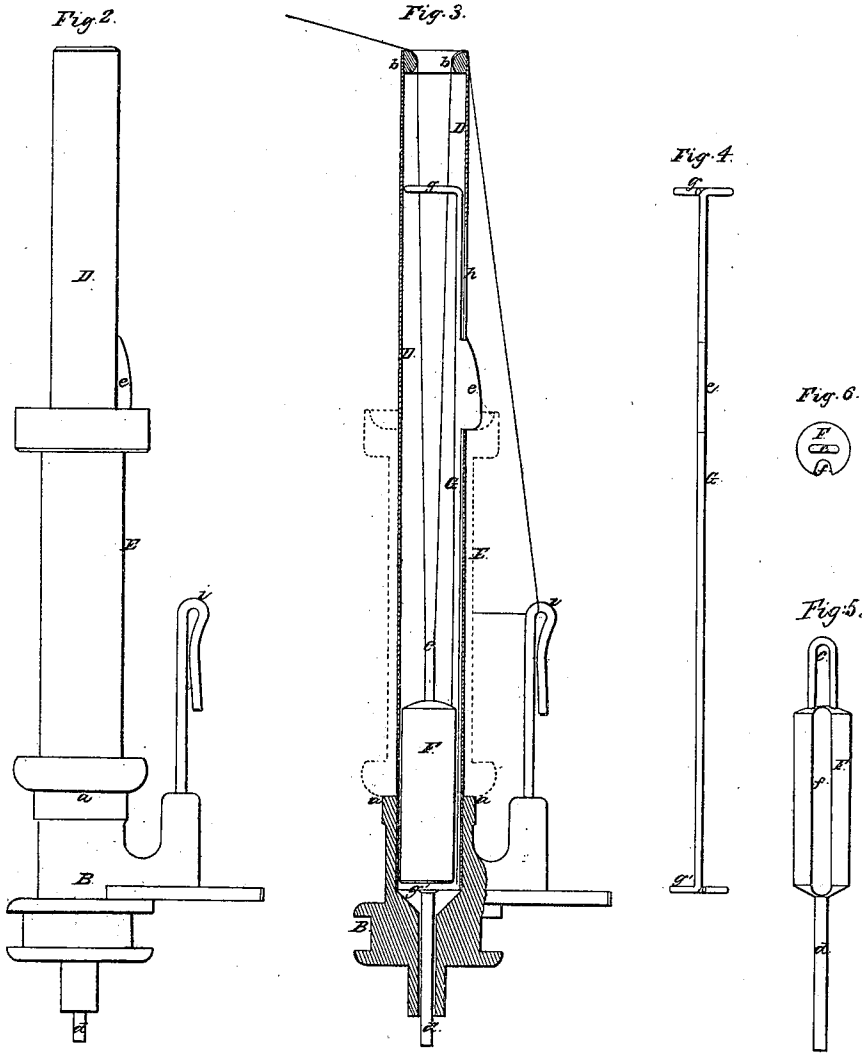

Witnesses:
J. W. Coombs
G. W. Reed

Inventor:
J. B. Wood
per Munn & Co
Attorneys

J. B. WOOD.
BRAIDING MACHINE.

No. 41,045.

Patented Dec. 22, 1863.

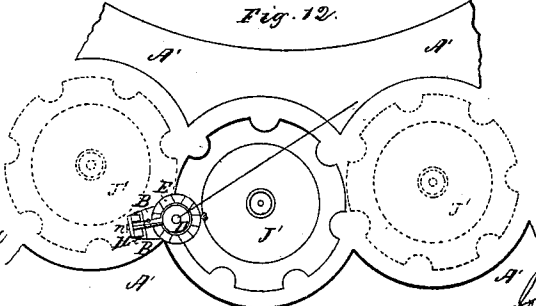
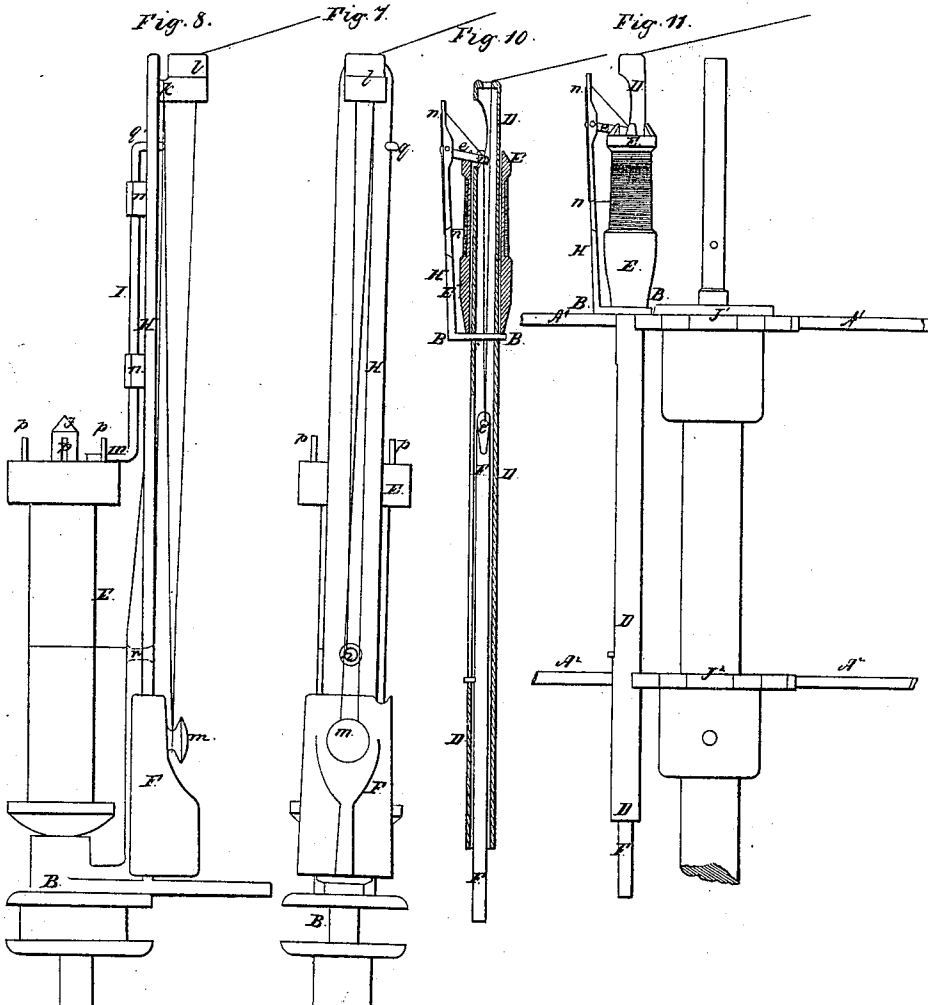

Witnesses:
 Jephth Brownell
 Seymour B. Hoff

Inventor:
 J. B. Wood

J. B. WOOD.
BRAIDING MACHINE.

No. 41,045.

Patented Dec. 22, 1863.

Fig. 9.

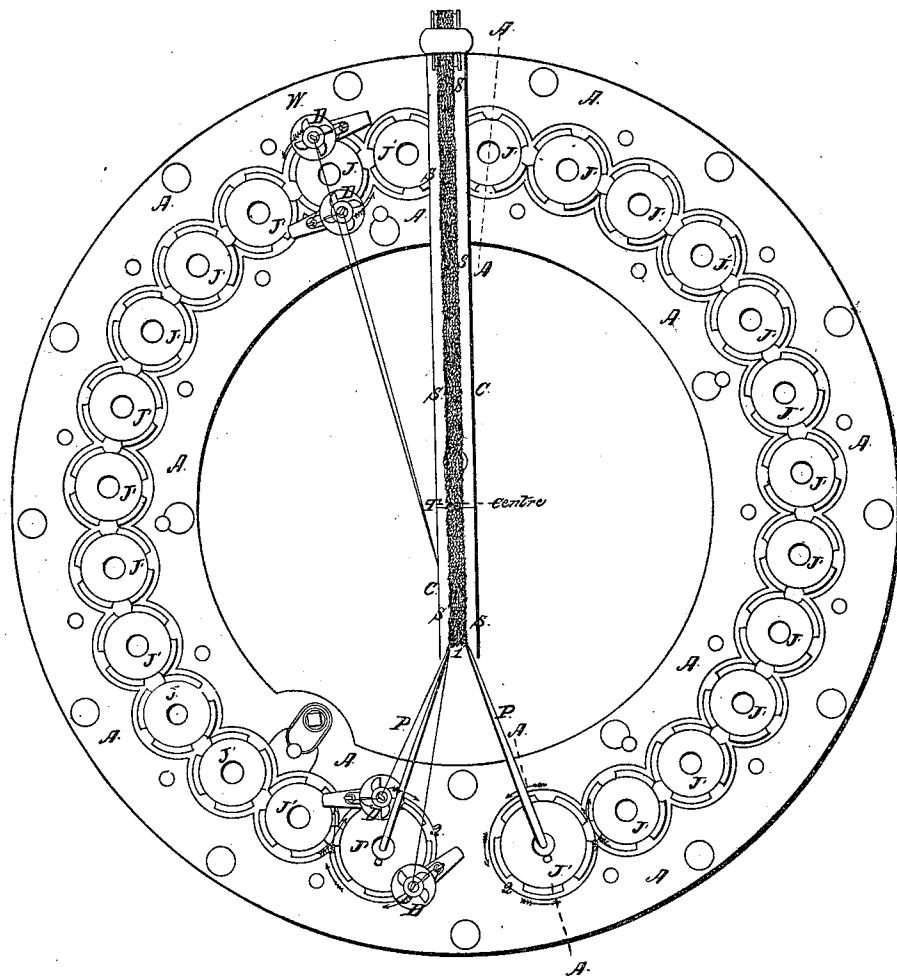

Witnesses:
Stephen Brownell
Lyman B. Goff.

Inventor:
John B. Wood

UNITED STATES PATENT OFFICE.

JOHN B. WOOD, OF PROVIDENCE, ASSIGNOR TO DARIUS GOFF, WILLIAM F. SAYLES, FREDERIC C. SAYLES, AND DARIUS L. GOFF, ALL OF PAW-TUCKET, RHODE ISLAND.

IMPROVEMENT IN BRAIDING-MACHINES.

Specification forming part of Letters Patent No. 41,015, dated December 22, 1863.

To all whom it may concern:

Be it known that I, JOHN B. WOOD, of Providence, in the county of Providence and State of Rhode Island, have invented a new and useful Improvement in Braiding-Machines; and I do hereby declare the following to be a full, clear, and exact description of the same, reference being had to the accompanying drawings, making part of this specification, in which—

Figure 1 is a vertical section of the braiding-machine in which my improved carrier is designed to be used. Fig. 2 is an elevation of one of the said carriers. Fig. 3 is a central vertical section of the same. Fig. 4 is a longitudinal view of the bobbin-stop of said carrier. Fig. 5 is an upright view of the tension-weight of the same. Fig. 6 is a top view of said weight. Figs. 7 and 8 are elevations at right angles to each other of a carrier, illustrating a modification of my improvement. Fig. 9 is a plan of the braiding machine, shown by vertical section in Fig. 1. Fig. 10 is a vertical section of the carrier used in the English braiding-machine. Fig. 11 is an elevation of said carrier and its carrier-wheels and shaft as arranged in said English machine. Fig. 12 is a plan of the same and adjoining part of the machine.

Similar letters of reference indicate corresponding parts in all the figures.

My improvement is expressly designed for the braiding of flat braid of the maximum widths and number of strands. It is an improvement on the English machine for braiding this description of braid, and is calculated to adapt the method employed in the English machine with two serpentine race-plates to the ordinary single-plate braiding-machine with a view to produce a machine of simpler construction and a more convenient operation than the said English machine for the manufacture of wide flat braid. Heretofore the wider flat braids have been exclusively made in foreign countries, and with the greatest perfection upon the said English machine, the distinctive features of which are that the braid is formed at a distance from the center of the serpentine pathway traversed by the carriers, and that the said pathway does not

continue entirely around the circle, but terminates in a full curve at two points in the circle nearest to the point at which the braid is formed, the selvage edges of the (flat) braid being formed by the passage of the carriers around these two terminal curves, and the interior portion of the braid by the passage of the carriers in their serpentine course departing and returning between these two points. In this method of braiding, at a certain point aside from the center of this serpentine course, the (flat) braid will be formed of uniform closeness and evenness of texture from side to side, and any departure therefrom in either direction with respect to the center will have the effect to braid more closely at the edges than in the middle of the braid, or vice versa, accordingly as the braiding-point is moved toward or from the center, thereby producing imperfect and inferior braiding. In the ordinary method employed in the said "single-plate machine," the braid is formed at the center of the serpentine pathway traversed by the carriers, and only a sufficient traverse of the tension-weights is required to enable the carriers to move in their serpentine course with an equal tension of each strand. In the English method, however, there is required, besides that traverse which provides for the said serpentine movement, an additional traverse of the tension-weight equal to double the distance at which the braiding-point is removed from the center to enable the carriers to move freely, and with an equal tension at the farthest as well as at the nearest point in the serpentine pathway to that at which the braid is formed; and as the braiding-point is the farthest removed from the center in braiding the widest braid with the greatest number of strands, the construction and arrangement of the carriers must be such as is calculated to afford sufficient traverse to the tension-weights, both for the serpentine movement of the carrier and for the approaching and receding movement of the same to and from the braiding-point at a distance from the center which, amounts to a traverse of about six inches in a braid of fifty-three strands three fourths of an inch wide. In order to obtain this amount of traverse,

the carrier in the English machine is constructed, as shown in Figs. 10, 11, and 12 of the accompanying drawings, consisting of a tube, D, the upper portion of which serves as a spindle for the bobbin E and the remaining portion inclosing the tension-weight F, which has a sufficient traverse below the base B of the carrier (on which the bobbin rests) to provide for the serpentine movement of the carrier and its approaching and receding movement to and from the braiding-point. With this construction the arrangement of the yarn-guides *n n*, &c., is such that the yarn (shown in red lines) passes from the bobbin E through the eyes *n n* in the upright rod H, thence through an eye in the swinging end of the latch *e*, which regulates the unwinding of the yarn from the bobbin, thence downward and through the eye *e* in the weight F and upward through the delivering-guide at the top of the tube, and thence to the braiding point.

To accommodate the traverse of the tension-weight F below the base of the carrier, the tube D extends so far downward in that direction as to require a second set of carrier-wheels J², and a second serpentine race-plate, A², which nearly doubles the size and cost of the machine, and is otherwise objectionable. The arrangement of the said yarn-guides, as described, is also objectionable, for the reason that it is necessary to lift the carrier completely out of the machine and turn it bottom upward in order to run the strand of yarn through the yarn-guides in the latch *e* and weight F, when it breaks or runs out, which requires considerable time and is most inconvenient.

The object of my invention is, therefore, to overcome these objections and by means of an improved carrier to braid the wider kinds of flat braid upon the single-plate machine by the method heretofore employed only in the "double-plate English machine," which has never before been done to my knowledge.

With this object in view, my invention consists in constructing the carrier and arranging its yarn-guides in such a manner that the tension-weight may have a sufficient traverse above the base of the carrier, or of a single plate, from which such carrier derives its serpentine movement to permit the braid to be formed at any required distance from the center of the machine; and my invention further consists in combining with the single plate-braiding machine a suitable "former," adapted to braiding without or at a distance from the center of such machine, substantially as hereinafter indicated and described.

In order that the nature and extent of my improvement may be fully understood, and to enable others skilled in the art to make and use the same, I will proceed to describe the same with reference to the annexed drawings.

A, Figs. 1 and 9, is the "race-plate," forming part of the frame of the single-plate machine. J' are the carrier-wheels, adapted to such race-plate and forming therewith the cir-

cular serpentine course traversed by the carriers in the operation of braiding, as shown in Fig. 9, the motion of said wheels being united by equal gears L on each, and both turning upon suitable studs projecting from the bed-plate A of the frame. U is the former employed in the English machine, having its crocheted end 1, which is the braiding-point, arranged at some distance from the center T of the circular plate A, and 2 2 are the terminal curves, around which the carriers pass in forming the selvage edges *s* of the flat braid, P P being two pointed rods, over which the yarn is laid to form the said edges. This construction and arrangement of parts being in all respects according to the method employed in the English machine above referred to; and it will be seen, by reference to Fig. 9, that a certain traverse of the tension-weight is required to allow the carriers D to run from the inside to the outside circumference of their serpentine course without varying the tension of the several strands, and that in addition to this a traverse which will take up the yarn as the carriers approach the braiding-point 1, and let it out again as they recede therefrom, and run at the farthest point in the circle from the former 1, as shown at W. In order to obtain this amount of traverse *e* in a single-plate machine, I make use of the carriers illustrated in Figs. 1 to 6, inclusive, the same consisting of a cast-iron base, B, of the form commonly adopted for the carriers of the single-plate machine, from which ascends a light upright tubular spindle, D, on which the bobbin E is fitted to turn freely, the said spindle being secured firmly in the casting and being of a length of about twice the height of the bobbin, which rests on the shoulder *a* of the cast-iron base B. In the upper part of the spindle D there is a living-ring, *b b*, which is rounded in such form as to allow the yarn to pass freely over it. The weight F is of cylindrical form and placed within the spindle, in which it is capable of working up and down freely, the said weight being furnished with an eye, C, at the top to receive the yarn. The spindle D also contains within it a light rod, G, which carries the latch *e*. This rod is composed of a piece of wire, which is straight except at its ends, which are bent in the form of rings and set at right angles to it, as shown at *g g'* in Figs. 3 and 4, to fit easily within the cylindrical interior of the spindle to keep the rod in place, and a groove, *f*, is provided in one side of the weight F for the said rod to slide freely through, the weight being arranged between the two rings *g g'*. The latch *e* is attached rigidly to the said rod G, and protrudes through an upright slot, *h*, in the tubular spindle, for the purpose of entering the notches in the top of the bobbin. Outside of the spindle D, on the same side with the slot *h*, a yarn-guide, *i*, is secured to the base of the carrier, the bend or eye of the said guide being about half the height of the bobbin. The yarn passes from the bobbin through the

guide *i*, thence upward over the edge of the tubular spindle *D* at *b*, through the eye *c* of the weight *F*, back over the opposite edge of the spindle at *b*, and thence to the former. As the carrier approaches the former, the weight *F* descends and draws down the yarn into the spindle, and as it recedes from the former the yarn is drawn up from the spindle, drawing up the weight *F*. The quantity of yarn which is held in reserve between the bobbin and the head of the spindle to be let out and taken back again is equal to twice the distance which the weight is allowed to move up and down the spindle, and thus, owing to the upward extension of the spindle, is about three times as much as can be let out and taken back again with a carrier of the construction commonly used in the single-plate braiding-machine, wherein the traverse allowed to the tension-weight is only so much as is required for the serpentine movement of the carrier. When the tension-weight *F* is drawn up into contact with the upper ring, *g*, of the latch-bar *G*, it lifts the said bar, and so lifts the latch *e* out of the notches in the head of the bobbin, and allows the bobbin to be turned to give out the yarn. With this construction of carrier, when the yarn break or runs out, it is only necessary to draw the yarn from the bobbin, hook it into the guide-eye *i*, and by means of a rod or wire, with a look at the end, the weight *F* is drawn up to the top of the tubular spindle *D*, when the end of the yarn may be readily run through the eye *C*, and the operation of the machine resumed in much less time than is required in the English machine.

In the modification of my invention represented in Figs. 7 and 8 the bobbin *E* is arranged upon a short spindle, *j*, as in the carriers commonly used in the single-plate machine, and the weight *F* is arranged to work on a guide-bar, *H*, outside of the bobbin; but the said guide is extended upward from the base *B* of the carrier to about twice the height of the bobbin, and the arrangement of the latch *I* is such that the weight *F* has a traverse on the said guide from its position as shown (at the base *B*) nearly to the top of the guide-bar, (until it comes in contact with and lifts the end *q* of the said latch *I*), a distance of six inches, with a let-off of twelve inches in length of yarn. While in the usual construction of the carrier, which provides merely for the serpentine movement before referred to, as set forth in the patent of A. B. Clemous, of November 16, 1858, the yarn passes through an eye in the guide midway between the two ends of the bobbin, and down outside of the guide under the lower end of the weight, which gives a traverse of but two and one-half inches ($2\frac{1}{2}$) of the weight and a let-off of but five (5) inches of yarn, which, though amply sufficient for the serpentine movement of the carrier forming braid at the center of the machine, is less than half the traverse required for the approaching and receding movement incident to the formation of wide

flat braid at a distance from the center for which my improved construction of the carrier and arrangement of the yarn-guides is expressly calculated, as set forth in the beginning. The guide-bar *H* has secured or formed at its top a guide, *k*, forming a neck to the guide-eye *l*, and the weight *F* has a stud or button, *m*, which serves as a yarn-guide. The yarn (shown in red lines) passes from the bobbin through the usual hole, *n*, in the guide-bar *H*, midway between the ends of the bobbin, thence upward outside the guide-bar, over the neck *k*, down under the neck of the button *m* on the weight, and up again to and through the eye *l*, whence it passes to the braiding, former 1. This arrangement of the yarn-guides does not differ in any practical sense from that first described, and shown in Figs. 2 and 3, for it will be seen that the guides *i*, Figs. 2 and 3, and *n*, Figs. 7 and 8, are both situated midway between the two ends of the bobbin; that the rounded ring *b b* in Figs. 2 and 3 and the neck *k* and eye *l* in Figs. 7 and 8 are both situated at the extreme top of the carrier, and that the eye *C* in Figs. 2 and 3 and the button *m*, in Figs. 7 and 8 are both situated upon and form part of the weight *F*; and, furthermore, the end *q* of the latch *I*, Figs. 7 and 8, is situated above the latch *m*², which immediately engages with the stops or pegs *p p* in the top of the bobbin to permit the weight to traverse to that height *q* precisely as is the ring *g*, situated above the latch *e*, Figs. 2 and 3, which immediately engages with the notches in the top of the bobbin and with the same object in view to give additional traverse to the weight to provide for the method hereby adapted to the single-plate machine of braiding at a distance from the center. On the same principle of arranging the said yarn guides, the yarn may pass twice between the neck *k* and button *m* of Figs. 7 and 8, or twice between the ring *b b* and eye *c* in the weight of Figs. 2 and 3, and thereby double the let-off of yarn from the same traverse of the weight. The weight alone has been hereinabove mentioned as a means for producing the requisite tension of the yarn in its delivery from the carrier, because it is, all things being considered, the best means for the purpose where an excessive motion or traverse is necessary, the nearest approach to an equivalent therefore being a coiled spring applied to wind a band upon a scroll-pulley, by means of which a tension is produced that is nearly equal throughout a traverse of six inches of an eye in the end of such band through which the yarn is passed; but from the fact that it is practically impossible to make a number of coiled springs of the same stiffness and winding-power, or to maintain the same at the same stiffness and power for any length of time, it is obvious that for the corresponding evenness of tension required in all of a large number of strands in braiding a flat braid with a traverse of five or six inches of the weight and a let off of ten or

twelve inches in length of yarn, any form or arrangement of a spring is both unsuitable and impracticable, and that the corresponding evenness of tension required in all the carriers can only be attained by the use of a number of weight of equal heaviness applied one to each braiding-strand.

I am aware that an arrangement of a spring-pulley, a lifter band, and ring to play within a hollow spindle has been heretofore patented by Edward B. Day, February 7, 1860; but as said spring-pulley is not a scroll-pulley the power of its spring would be so multiplied with a sufficient traverse to braid at a distance from the center, and the variation in the power of the different springs would produce such a variety of tension in the several strands as to pucker the braid and render it entirely worthless, that it is only calculated for the small amount of traverse required for the serpentine movement of the carriers, and is unsuitable and impracticable for braiding wide flat braid at a distance from the center of the machine. It will be seen that the bases B B of the carriers are based upon and operate within the single serpentine plate A, and that the carriers and their auxiliary parts are all arranged and operate above their said bases with that degree of traverse which adapts the single-plate machine to the braiding of wide flat braid, which has only heretofore been accomplished by means of a similar traverse below the base of the carrier and the two serpentine plates and two sets of carrier-wheels of the more complicated and expensive English machine above referred to.

Having thus described my invention with reference to the particular branch of manufacture for which it is designed, I wish it understood that I do not claim any arrangement of a tension weight with the carrier of a braid-

ing-machine which simply provides for the serpentine movement of the carrier-braiding at the center of the machine, as set forth in A. B. Clemon's patent of November 16, 1858. Neither do I claim the arrangement of a spring-pulley, lifter-band, and ring as a substitute for the tension-weight to provide for the serpentine movement of the carrier, as set forth in Edwd. B. Day's patent of February 7, 1860, as neither of the said devices are capable of affording the degree of traverse with the requisite evenness of tension in any number of strands, which is the object of my present improvement. Nor do I claim that construction of the carrier and arrangement of its yarn-guides which provides for a sufficient degree of-traverse below the base of the carrier as employed in the English double plate machine, as such arrangement is wholly unsuitable for use in the single-plate braiding-machine, for which my improvement is expressly designed.

What I claim, and desire to secure by Letters Patent, is—

1. So constructing the carrier and arranging its yarn-guides that the tension-weight may have a sufficient traverse above the base of the carrier or racer to allow wide flat braid to be formed at any required distance from the center in the single-plate braiding-machine, substantially as herein specified.

2. Combining with a single-plate braiding-machine, substantially as described, the former C, or its equivalent, adapted to braiding at a distance from the center, substantially as described, for the purpose specified.

JOHN B. WOOD.

Witnesses:

STEPHEN-BROWNELL,
LYMAN B. GOFF.