

Aug. 8, 1961

R. RAGAN

2,995,004

SPINNING AND TWISTING RING

Filed Jan. 6, 1958

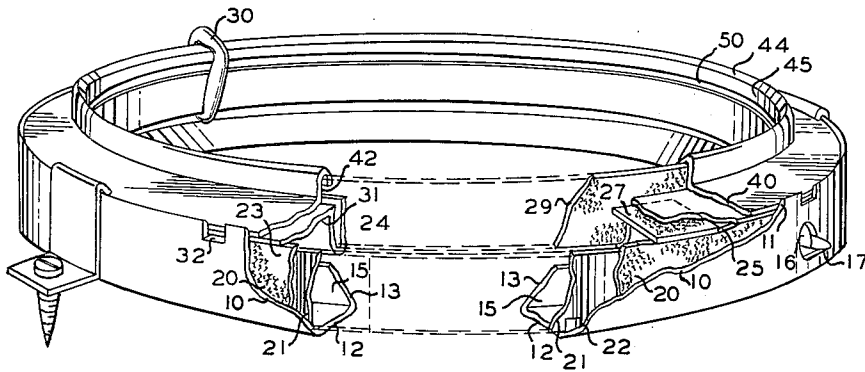

FIG. 1

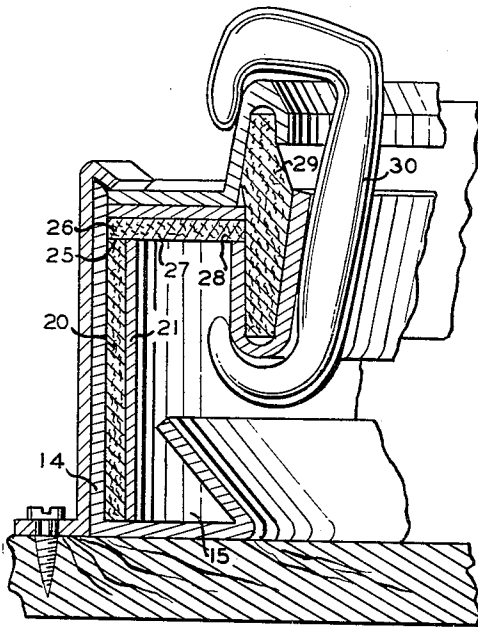

FIG. 2

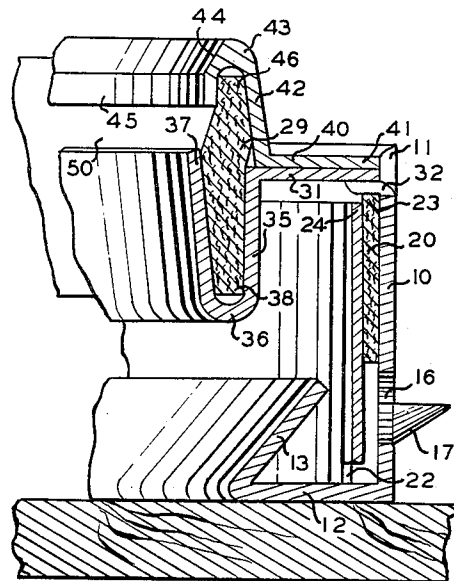

FIG. 3

INVENTOR:
RALPH RAGAN

BY:

ATTORNEY

1

2,995,004

SPINNING AND TWISTING RING

Ralph Ragan, 11 W. Andrews Drive NE., Atlanta, Ga.

Filed Jan. 6, 1958, Ser. No. 707,382

15 Claims. (Cl. 57—120)

This invention relates to spinning and twisting rings, and is more particularly concerned with spinning and twisting rings for textile fibers and holders therefor incorporating novel and improved means for maintaining effective and efficient lubrication for a traveler supported by the ring and rotating thereover.

A primary objective in the design and construction of traveler rings for twisting and spinning of the textile industry has been to provide simplicity, durability and economy of manufacture without sacrifice of efficiency in operation. Such rings are required by the industry in the hundreds of thousands, and it will be understood that even a slight saving in the cost of an individual ring represents a substantial factor of economy in the total industry. Since the speed of rotation of the traveler about the ring is in the thousands of revolutions per minute, one of the important considerations in the design and construction of such rings is the problem of lubrication and cooling in order to reduce friction and enhance the useful life of both ring and traveler. Such lubrication has in the past been achieved by the use of oil saturated wick structures over which the traveler passes to maintain a lubricant film thereon. Several problems arise with respect to such lubrication; one being the necessity for continuous replenishment of lubricant to the individual rings, another is the danger of contact of the lubricant with the material being spun. With the advent of nylon or like plastic travelers for the rings, heating by frictional contact has become increasingly serious and thus minimum contact of the traveler with the ring is desirable. If contact of the ring with lubrication wicks is presented, carbonization of the wick will ensue and oil flow will be retarded. Where thousands of rings are employed in a single mill, it will be seen that the problem of maintaining adequate lubricant is an arduous and time consuming operation while the soiling of the spun material by contact with the lubricant may cause the rejection of expensive quantities of spun or twisted material.

The present invention provides a novel, simple and improved construction made of a minimum number of simply and easily formed parts providing a rugged and durable construction together with means for maintaining a sump or reservoir for lubricant and coolant minimizing the necessity of continuous replenishment of lubricant together with a structure by which the contact of the material being spun with the lubricant is inhibited. The ring of the present invention also permits replenishing of the lubricant without cessation of spinning operation. In operation, the traveler has minimum contact with the ring and no contact with the lubricant supply wick. More specifically, that form of the invention here shown by way of example may be generally defined as comprising an outer casing defining a lower inwardly extending lubricant supply reservoir or chamber from which the lubricant is led upwardly by capillary action through an annular wick to be transferred inwardly and adjacent the path of travel of the outer surface of the traveler body by capillary means. The traveler is arranged to move over the ring with minimum frictional contact and hence with minimum heat generation, being air cooled by virtue of its velocity. No contact between the traveler and the oil wick is permitted, lubricant moves from the wick to the ring by forces arising from the velocity of the traveler, hence no burning or carbonizing of the wick is permitted. The construction and arrangement of parts

2

is such that while the inner surface of the traveler body may be copiously supplied with adequate lubricant, excess lubricant will be returned to the sump for recirculation by discharge from the traveler through centrifugal force. In carrying out the invention the number of parts has been maintained at a minimum, and the construction of each is simple and well designed to meet the demands of economic manufacture whereby the ring may be produced and distributed at a cost representing a substantial saving to the industry.

It is therefore among the primary objects of the present invention to provide a novel and improved spinning and twisting ring of simple, rugged and durable construction incorporating improved means for maintaining adequate lubrication for minimum friction and ample thread space for a traveler mounted thereon and rotating thereover.

Another object of the invention is to provide a twisting and spinning ring incorporating therein a lubricant reservoir for maintaining an adequate supply of lubricant and coolant over a substantial period of time, thus avoiding the necessity of repeated applications of lubricant at frequent intervals, and one in which the lubricant may be replenished without termination of the spinning operation.

It is also among the objects of the present invention to provide a device of the character set forth including means for insuring a circulation of lubricant so as to insure an adequate supply of lubricant at all times to the traveler without direct contact of the traveler with the lubricant supply wick, and hence without wear or charring or damage of such wick.

A further object of the present invention is to provide a ring and traveler combination by which minimum traveler contact with the ring is insured while maximum cooling and adequate lubrication is provided and contact of lubricant with the material being spun is inhibited so as to insure a clean finished product.

The objectives of the present invention also include that of providing a twisting and spinning ring of simple construction, the parts of which may be readily formed by a simple manufacturing method and assembled without special tools or skills so as to provide a device at a cost representing a substantial saving to the industry.

Numerous other objects, features and advantages of the present invention will be apparent from consideration of the following specification, taken in conjunction with the accompanying drawing in which:

FIG. 1 is a perspective view, partly broken away, of one embodiment of the present invention.

FIG. 2 is an enlarged vertical cross section through one side of the ring illustrating the lubricant passage from sump to discharge wick.

FIG. 3 is a similar cross section illustrating one of the assembly features and the lubricant replenishing means.

Referring now more particularly to the drawings, it will be seen that the present embodiment of the invention includes an external supporting body of generally circular form including a cylindrical side wall 10 open at the top in a plain cylindrical vertical edge 11 and formed at its lower edge with an inwardly extending annular horizontal bottom wall 12. The wall 12 terminates inwardly in an upwardly and outwardly inclined frusto-conical wall 13. The lower annular portion 14 of the side wall 10 together with the horizontal bottom 12 and the inclined wall 13 defines a lubricant supply reservoir or sump 15 constituting a repository for an ample supply of lubricant which precludes the necessity for frequent servicing or replenishment of lubricant, in the form of a light penetrating oil. A small area of the lower portion 14 of the side wall 10 is apertured as at 16, the material therefrom being struck out to constitute a filling spout 17 adapted to receive the liquid lubricant externally of the body and direct the same into the reservoir 15. This construction is such as

to provide for such filling and replenishment with a minimum danger of loss of lubricant or discharge thereof in such manner as to contact material being spun. An important feature of the invention is the ability to replenish lubricant during operation without loss by shutdown time.

For supplying lubricant upwardly from the reservoir 15 to the area inwardly of the upper edge 11 of the body, there is provided a simple flat annular supply wick 20 vertically positioned and retained against and parallel with the inner wall of the body 10 by the flat annular spring band 21. It will be understood that the wick 20 may be formed of a single straight length of absorbent fibrous wick material adapted to convey the lubricant by capillary action, and of a length commensurate with the internal diameter of the wall 10 so as to fit snugly thereagainst without overlap and with the opposed ends thereof in substantial vertical contact. It will likewise be understood that the spring retaining band 21 is of a length commensurate with the internal diameter of the wick 20. The inherent resiliency of the band 21 maintains the band in expanded position maintaining the wick in vertical position without undue pressure, the ends of the band being in parallel relation without overlap.

As indicated at 22 the lower edge of the band 21 may be provided with notches 22 spaced upwardly from the inner face of the bottom 12 to facilitate the absorption of lubricant by the wick and the migration thereof upwardly through the wick. Under normal manufacturing methods, the fit of the parts is normally such as to provide adequate seepage of lubricant from the reservoir 15 to the wick without the necessity for a special construction or spacings or apertures for lubricant admission to the wick 20. The upper edge 23 of the wick 20 extends for the major part of its circumference slightly above the upper edge 24 of the retaining band 21. Such edge is, however, reduced at diametrically opposite points by elongate notches 25 which receive therein the outer ends 26 of transverse inwardly extending secondary feeder wicks 27 receiving lubricant from the supply wick 20. The inner ends 28 of feeder wicks 27 are in contact with and deliver lubricant to an annular generally vertical discharge wick 29. In the flow of lubricant which, as stated, is preferably a light penetrating oil, the lubricant is elevated by capillary action from the reservoir 15 through the vertical supply wick 20 and inwardly through the horizontal secondary feeder wicks 27 to the vertical discharge wick 29 from which it passes to the traveler 30. From the traveler 30 excess lubricant will be spun automatically by centrifugal force to return to the reservoir 15 in the manner hereinafter further discussed.

As above noted, the upper edge 23 of the vertical supply wick 20 terminates below the upper open end 11 of the body 10 and there is fitted within the upper edge 11 above the top edge of the wick 20 a discharge wick support. This support comprises upper and lower wick supports, the lower support including an annular peripheral flange 31 the outer edge of which is of diameter commensurate with the internal diameter of the upper edge 11 so as to provide for a snug fit of the flange therein without requiring special tools or methods for assembly or securing means. A frictional contact suffices to maintain the parts in assembled relation. Detents 32, however, are struck inwardly at desired spacing about the edge 11 to provide a rest for the edge of the flange 31 to preclude the inadvertent inward movement of the flange beyond the desired horizontal disposition thereof. At the inner circumference of the flange 31, there is formed a downwardly extending flange 35 terminating at its lower end in a return bent U portion 36 and upwardly and slightly inwardly therefrom extends the companion flange 37, the flanges 35 and 37 constituting a U-shaped receiving pocket for the lower portion 38 of the annular discharge wick 29.

In cooperation with the lower discharge wick support, there is provided a somewhat similar but inverted U upper discharge wick support including a peripheral hori-

zontal flange 40, the outer edge 41 of which registers with the outer edge of the lower support which is received therewith by frictional fit within the upper edge 11 of the body 10. The inner edge of the flange 40 is formed with an upstanding annular flange 42 terminating with an upper inverted U bend 43 merging into an inwardly inclined upper wall surface 44 which terminates in a downwardly extending vertical terminal wall 45. It will be seen that the generally inverted U formation formed by the walls of the upper support provide a receiving annulus for the upper edge 46 of the generally vertical annular discharge wick 29. Thus, in cooperation with the U-shaped formation of the return bend of the lower discharge wick supporting member, an adequate mounting for both the upper and lower edges of the discharge wick is provided, leaving an open space 50 therebetween at which area the inner face of the discharge wick is exposed. It will be noted, however, that the inward inclination of the inner wall 37 of the lower discharge wick support is inwardly disposed with respect to the vertical wall 45 of the upper member, and hence the traveler 30 is mounted in such manner as to be free of actual contact with the discharge wick 29 at the exposed area 50. This position of the traveler is indicated in FIG. 2 and acts to insure spacing of the traveler from the wick to prevent friction and charring of the wick. This spacing also insures free air flow to cool the traveler and to permit oil to be drawn to the traveler by such air flow as the traveler passes near the wick at high speed. This spacing of the traveler by the level of the element 45 also insures ample thread room for the passage of thread without contact with the ring.

In the operation of the device, it will be seen that as the lubricant is drawn upwardly from the reservoir 15 by the vertical feed wick 20, it will pass inwardly through the wicks 27 to saturate the discharge wick 29. As the traveler 30 is rotated at high velocity, supported by the combined walls 42 and 35 of the wick mounting members, such movement will by virtue of its speed create a suction and air movement such as to cause the lubricant to flow by aspiration through the space 50 to the traveler whereupon it flows along the inner surface thereof to lubricate the walls 45 and 37. Since the reservoir will maintain a substantial amount of lubricant adequate for long periods of operation such flow will be maintained without supervision.

It will of course be understood that the flow of lubricant thus established may be in substantial excess of that required to maintain the necessary oil film to reduce friction, and such excess liquid lubricant will pass from the lower end of the traveler outwardly by centrifugal force and by air flow to be thrown against the retaining plate 21 and travel downwardly into the reservoir 15 to establish a recirculation of lubricant. Not only is such recirculation effective in maintaining an adequate supply of lubricant over a long period of operation, but such recirculation provides an economy in lubrication, since excess lubrication which otherwise might be flung from the ring is retained therein for reuse. Such capture of excess lubricant also provides means for inhibiting the discharge of lubricant in such manner as to cause contact with the material being spun and to the detriment thereof.

It will of course be understood that the invention is not confined or limited to specific materials which may be employed, it being understood, however, that suitable metal stampings may be utilized in the construction of the body as well as the upper and lower distributing wick supports. It will be noted that this construction avoids the necessity of threaded securing means or other special attaching elements and that the parts may be readily formed from stampings or in other equally economical manner. The wick elements are preferably formed of felt or like material through which capillary action acts in the conveyance of the lubricating material. It will

of course be understood that the invention is not limited or confined to the specific structural details herein enumerated and that numerous changes, modifications and the full use of equivalents may be resorted to in the practice of the invention without departure from the spirit or scope of the appended claims.

I claim:

1. In a spinning ring, a lubricant discharge wick located adjacent the path of movement of a traveler supported by said ring, said ring having an annular U-shaped pocket receiving said discharge wick and for retaining excess lubricant from said discharge wick, a laterally disposed feeder wick adapted to deliver lubricant to said discharge wick, a supply wick in contact with said feeder wick for delivering lubricant thereto, and means for supplying lubricant to said supply wick.

2. In a spinning ring, a lubricant discharge wick located adjacent the path of movement of a traveler supported by said ring, said ring having an annular U-shaped pocket receiving said discharge wick and for retaining excess lubricant from said discharge wick, a laterally disposed feeder wick adapted to deliver lubricant to said discharge wick, a supply wick in contact with said feeder wick for delivering lubricant thereto, and a lubricant reservoir for receiving excess lubricant from the traveler and delivering lubricant to said supply wick.

3. In a spinning ring, an annular lubricant discharge wick located adjacent the path of movement of a traveler supported by said ring, a pair of diametrically opposed feeder wicks adapted to deliver lubricant to said discharge wick, an annular supply wick in contact with said feeder wicks for delivering lubricant thereto, said ring having an annular U-shaped pocket receiving said discharge wick and for retaining excess lubricant from said discharge wick, and an annular lubricant reservoir for receiving excess lubricant from the traveler and delivering said lubricant to said supply wick.

4. A spinning and twisting ring including an annular body, an annular generally U-shaped lower wick supporting member mounted in said body, an annular generally U-shaped upper wick supporting member mounted in said body in superposed relation to said lower wick supporting member, said members defining an inner annular open area therebetween, a traveler extending around the outer part of the U-shaped portions of said members and across said open area and a wick mounted between said members and extending across said open area.

5. A spinning and twisting ring including an annular body, an annular generally U-shaped lower wick supporting member mounted in said body, an annular generally U-shaped upper wick supporting member mounted in said body in superposed relation to said lower wick supporting member, said members defining an inner annular open area therebetween, a traveler extending around the outer part of the U-shaped portions of said members and across said open area a wick mounted between said members and extending across said open area, and means for supplying lubricant upwardly in said body to said wick.

6. A spinning and twisting ring including an annular body defining an annular lubricant chamber, an annular generally U-shaped lower wick supporting member mounted in said body, an annular generally U-shaped upper wick supporting member mounted in said body in superposed relation to said lower wick supporting member, said members defining an inner annular open area therebetween, a traveler extending around the outer part of the U-shaped portions of said members and across said open area a wick mounted between said members and extending across said open area, and means for supplying lubricant upwardly in said body to said wick.

7. A spinning and twisting ring including an annular body defining an annular lubricant chamber, an annular generally U-shaped lower wick supporting member mounted in said body, an annular generally U-shaped upper wick supporting member mounted in said body in

superposed relation to said lower wick supporting member, said members defining an inner annular open area therebetween, a wick mounted between said members and extending across said open area, and means for supplying lubricant upwardly in said body to said wick, said chamber having an open top for the reception of lubricant and a sump for receiving lubricant from said traveler.

8. A spinning and twisting ring including an annular cylindrical body formed with an inwardly extending bottom flange and an outwardly inclined inner wall defining a lubricant sump, a first wick mounted vertically within said body to lift lubricant from said sump by capillary attraction, an annular traveler bearing ring supported within said body, and a vertically disposed annular wick for directing lubricant from said first wick inwardly toward the inner periphery of said ring, there being provided an annular space of less height than said annular wick in said bearing ring and communicating with said annular wick and said traveler.

9. A spinning and twisting ring including an annular body, a pair of traveler bearing rings having flat abutting flanges mounted in said body, each of said rings providing cooperating inner generally vertical spaced traveler bearing surfaces extending from said flanges, said body defining a lubricant sump, and means for delivering lubricant from said sump to the area between said spaced surfaces.

10. A spinning and twisting ring including an annular body, a pair of traveler bearing rings mounted in said body, each of said rings providing cooperating inner generally vertical spaced traveler bearing surfaces, said body defining a lubricant sump, and means for delivering lubricant from said sump to the area between said spaced surfaces, the inner generally vertical surface of one of said rings being inwardly inclined and of less minimum internal diameter than the companion surface of the other ring.

11. A spinning and twisting ring including a cylindrical body, a bottom wall and an inwardly inclined flange on said body defining a lubricant reservoir, a spout formed by an opening in said body for the reception of lubricant through said body to be received by said reservoir, an annular upwardly extending wick mounted in said body, a resilient band for retaining said wick in position against the inner wall of said body, a pair of superposed relatively inverted generally U-shaped rings mounted in said body, a second annular wick mounted between said rings in the U portions thereof, and means for delivering lubricant from said first mentioned wick to said second mentioned wick.

12. A spinning and twisting ring including a cylindrical body, a bottom wall and an inwardly inclined flange on said body defining a lubricant reservoir, an annular vertical wick mounted in said body, a resilient band for retaining said wick in vertical position against the inner wall of said body, a pair of relatively inverted superposed generally U-shaped rings mounted in said body, a second annular wick mounted between said rings in the U portions thereof, and means for delivering lubricant from said first mentioned wick to said second mentioned wick, the U portions of said rings being spaced to expose an annular area of said second wick for the discharge of lubricant therefrom to a traveler moving over said rings.

13. A spinning and twisting ring including a cylindrical body having a lubrication reservoir, a first wick leading upwardly from said reservoir, a pair of superposed rings mounted on said body above said reservoir, said rings including flat abutting peripheral flanges and opposed bearing surfaces inwardly of said flanges for receiving a traveler thereon, said surfaces defining therebetween a wick receiving annulus, there being provided an annular space between the inner edges of said surfaces communicating with said receiving annulus, said space being of less width than said annulus, an annular wick within said wick receiving annulus, and a third wick extending from said first wick and communicating with said annular wick for

7

delivering lubricant from said reservoir by capillary action through the aforesaid wicks and between said space to said traveler.

14. A spinning and twisting ring including a cylindrical body having a lubrication reservoir, a first wick leading upwardly from said reservoir, a pair of superposed rings mounted on said body above said reservoir, said rings including flat abutting peripheral flanges and portions inwardly of said flanges for receiving a traveler thereon, said portions defining therebetween a wick receiving annulus and an annular space between the inner edges of said portions communicating with said receiving annulus, said space being of less width than said annulus, a vertically disposed annular wick within said wick receiving annulus and extending below said space, and a third wick extending from said first wick and communicating with said second wick whereby lubricant in said reservoir is delivered by capillary action through the aforesaid wicks and between said space to said traveler.

15. A spinning and twisting ring including a cylindrical body having a lubrication reservoir, a first wick carried by said body and leading upwardly from said reservoir, a resilient band for retaining said first wick on said body, a pair of superposed rings mounted on said body above

8

said reservoir, said rings including flat abutting peripheral flanges and portions inwardly of said flanges for receiving a traveler thereon, said portions defining therebetween a wick receiving annulus and an annular space between the inner edges of said portions communicating with said receiving annulus, said space being of less width than said annulus, an annular wick within said wick receiving annulus, and a third wick extending from said first wick and communicating with said second wick whereby lubricant in said reservoir is delivered by capillary action through the aforesaid wicks and between said space to said traveler and returned by said traveler to said reservoir as said traveler is moved along said portions.

References Cited in the file of this patent

UNITED STATES PATENTS

743,138	Booth	Nov. 3, 1903
1,918,644	Hofmann	July 18, 1933
1,986,910	Aldrich et al.	Jan. 8, 1935
2,012,395	Litchman	Aug. 27, 1935
2,565,578	Stahl	Aug. 28, 1951
2,815,639	Ridgway	Dec. 10, 1957