

July 6, 1948.

D. SAMIRAN ET AL

2,444,471

SWITCH

Filed Sept. 29, 1943

2 Sheets-Sheet 1

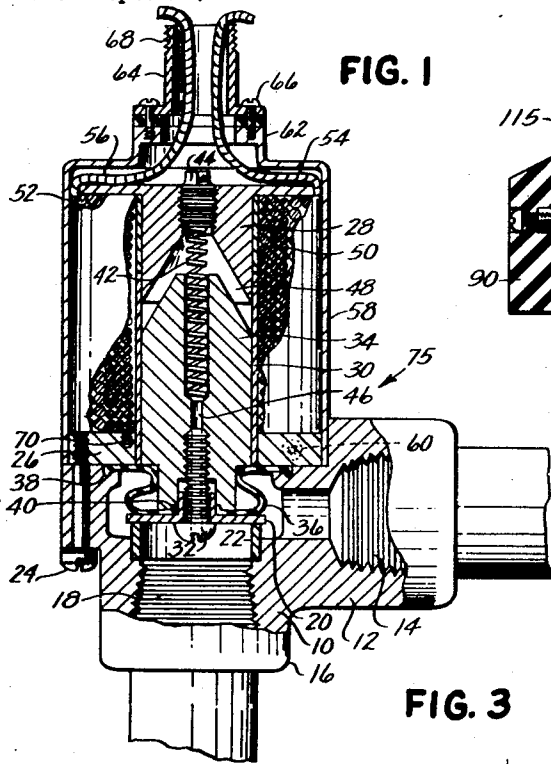

FIG. 1

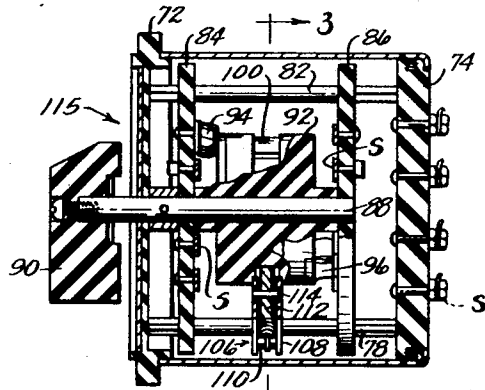

FIG. 2

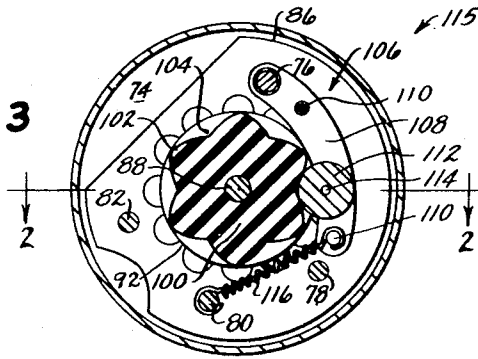
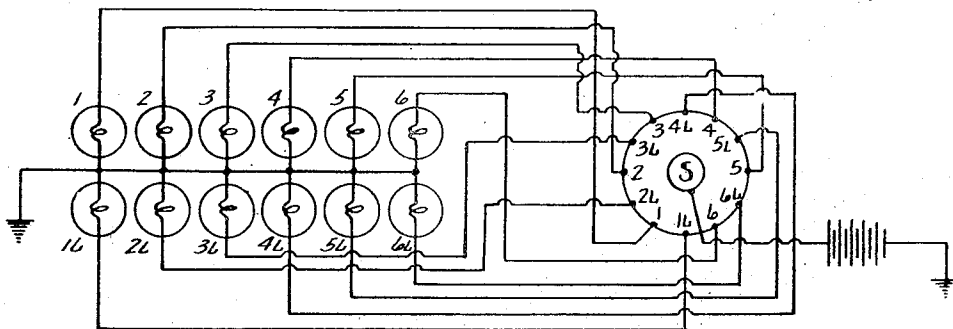

FIG. 3

FIG. 5



INVENTORS  
 DAVID SAMIRAN  
 GEORGE W. REBLOGLE  
 BY Joseph W. Hazell  
 Charles Koenig ATTORNEYS

July 6, 1948.

D. SAMIRAN ET AL

2,444,471

SWITCH

Filed Sept. 29, 1943

2 Sheets-Sheet 2

FIG. 4

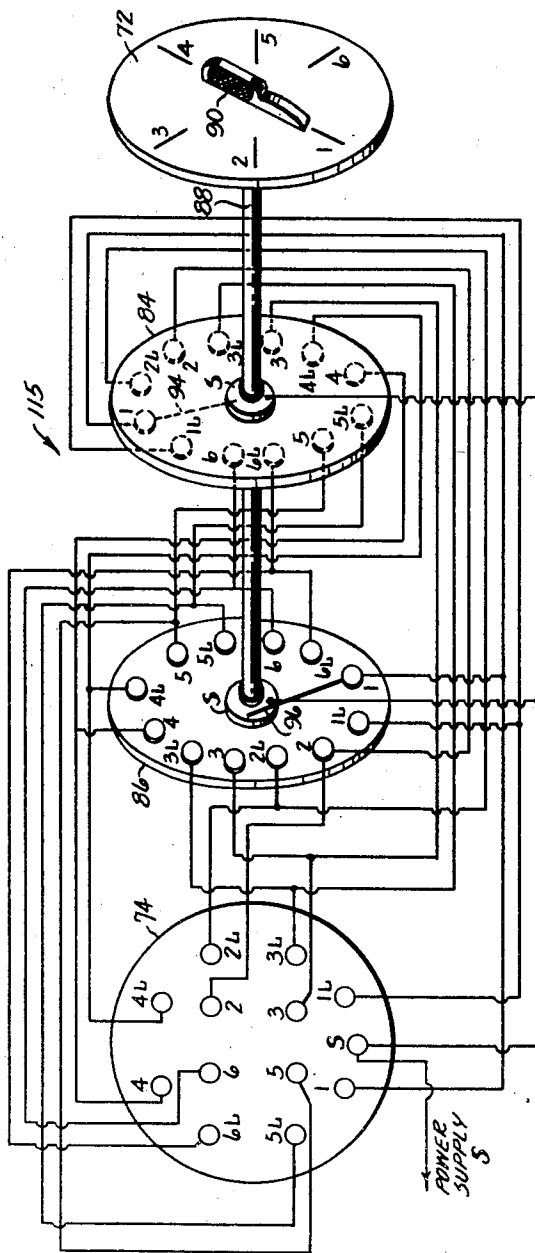

BY

INVENTORS  
DAVID SAMIRAN  
GEORGE W. REPLOGLE  
*Joseph W. Hazell*  
*Charles Conity* ATTORNEYS

# UNITED STATES PATENT OFFICE

2,444,471

SWITCH

David Samiran, Osborn, and George W. Replogle,  
Dayton, Ohio

Application September 29, 1943, Serial No. 504,264

3 Claims. (Cl. 200—6)

(Granted under the act of March 3, 1883, as  
amended April 30, 1928; 370 O. G. 757)

1

The invention described herein may be manufactured and used by or for Government for governmental purposes, without the payment to us of any royalty thereon.

This invention relates to a control switch for a series of solenoid-operated valves and may have a variety of uses, such, for example, as controlling the flow from a series of fuel tanks on an aircraft.

An object of the invention is to provide, in a device of this character, electrically energized valve-opening means which first utilizes ample electrical energy for operating the valve to its open position, then reduces the applied energy to the minimum required for holding the valve open.

Another object is to provide, in combination with a series of electrically operated valves of the kind mentioned, a selective switch mechanism particularly applicable to their operation in the manner indicated.

Other objects and advantages will become evident as the invention is described in greater detail, reference being had to the diagrams and drawings wherein:

Fig. 1 is an axial section through one of the solenoid valves showing the double winding.

Fig. 2 is an axial section through the multiple switch used in connection with a series of the solenoid valves shown in Fig. 1, the section being taken through the rotating and several of the movable contact members at 2—2 of Fig. 3.

Fig. 3 is a transverse section through the switch taken at 3—3 of Fig. 2, showing a snap action means of novel construction.

Fig. 4 is a schematic illustration of the switch arranged for connection to a series of the solenoid valves to be operated, the wiring diagram, showing the connections, being included.

Fig. 5 shows a simplified, though somewhat less effective, arrangement of the switch and valves.

Like reference characters have reference to like parts throughout the several drawings and diagrams.

Referring more particularly to Fig. 1, a valve body 10 has a hub 12 for a fluid inlet opening 14, and a hub 16 for a fluid outlet opening 18. A valve disk 20 is concentric with the outlet opening 18 and rests on a valve seat member 22 which is preferably press-fitted into a recessed portion of the hub 16.

Attached to the upper side of the valve body 10 by screws 24 is a solenoid spool which comprises a lower head 26, an upper head 28, and a connecting tube 30, these three main parts of the spool being preferably press-fitted together, the upper

2

head into the tube and the lower head over it. The tube 30 should preferably be made of non-magnetic material to break the continuity of the magnetic circuit.

Attached to the upper side of the valve disk 20 by a screw 32 is a solenoid core 34. Core 34 is freely slidable in the tube 30 of the solenoid spool. A diaphragm gasket 36 is held clamped at its outer edge between the body 10 and the spool head 26, and at its inner edge between the solenoid core 34 and the valve disk 20. An annular bead 38 around the outer edge of the gasket is held under compression in a suitably shaped groove in the top surface of the body 10, while another annular bead 40 is held under compression in a suitable groove in the lower face of the core 34.

A spring 42 has its lower end nested in an opening in the core 34 and its upper end resting against the lower end of a pipe plug 44 which is screwed pressure-tight into the upper head 28 of the solenoid spool. A small hole 46 extends upwardly through the screw 32 and through the core 34, so that the suction pressure in the outlet opening 18 and in the space 48 above the core is equalized. In this way the pump suction will not materially augment the valve closing effort of the spring 42.

A fine wire coil 50 is first wound on the solenoid spool, then a coarse wire coil 52 is wound upon the coil 50. A flexible cable 54 extends from the coil 50, and a cable 56 from the coil 52. A housing 58 enshrouds the coil, its lower open end being held to the lower spool head 26 by screws 60, and its upper end being closed in to form the hub 62 to which a flanged member 64 is fastened by small screws 66. The member 64 is threaded as at 68 at the upper end for connection to an electric cable conduit, the cables 54 and 56 being brought out through the member 64 into the conduit (not shown). The inner ends of both coils may be grounded to a single screw 70 in the lower spool head 26. The complete solenoid valve may be broadly designated by the numeral 75.

From a consideration of the above description of the solenoid valve 75 shown in Fig. 1, it will be obvious that, by application of sufficient electrical energy to the solenoid coils, the solenoid core 34 will rise and lift the valve disk 20 with it. It should be observed, however, that when the valve disk 20 is on the seat 22, it is being held thereon not only by the spring 42 but additionally by whatever pressure may be present in the inlet opening 14. Since the sum of these two pressures is considerable, a solenoid coil of relatively large lifting capacity is required to raise the valve disk

from the seat, but after it is so raised a solenoid coil of relatively small lifting capacity will hold the valve disk in the open position.

It is for this reason that the two coils 52 and 50 are provided, the coil 52 being of sufficient capacity to lift the valve to open position, and the coil 50 being of that capacity only which is required for maintaining the valve in open position once it has been opened. For convenience in further description, the coarse wire coil 52 may hereinafter be referred to as the lifting coil, while the fine wire coil 50 may be called the holding coil. Such an arrangement in a solenoid valve is, of course, fully effective only when used in combination with some sort of electric switch which will direct the large volume of current to the lifting coil 52 of the solenoid for that fraction of a second only which is required to open the valve, then will cut off the current flowing through the lifting coil 52 and direct it through the holding coil 50 to hold the valve open.

Such an arrangement contributes largely to the success of the device, since the valve, once opened, must be held open for an extended period of time, and if the lifting coil were maintained in operation for such extended period it would not only result in excessive heating but would consume an excessive amount of current.

The valve structure shown has, as one of its important applications, the remote control of the contents of a series of fuel tanks of an aircraft by providing each tank with one of the valves, then successively connecting first one, then another, of the tanks to the fuel line by selectively operating the valves electrically. Accordingly, the embodiment shown to illustrate the invention may conveniently comprise six tanks, each having, at its outlet, one of the valves 75 illustrated and described with reference to Fig. 1, the six valves being used in combination with a sextuple switch for directing current, one at a time, to the selected one of the six valves, with means in the switch for momentarily energizing the lifting coil, then permanently energizing the holding coil of the valve selected.

The sextuple switch, shown in Figs. 2 and 3, has a frame which comprises a front member 72 and a rear member 74, both of insulating material and held axially spaced apart by a series of posts 76, 78, 80 and 82. The front member 72 (see also Fig. 4), on its forward face, carries the indicia of the several switch positions 1 to 6, while the rear member 74 carries the series of terminals, one terminal S for bringing the power-supply line into the switch, and the remainder for directing current to the twelve coils which operate the six valves, terminals 1L to 6L being employed for directing current to the lifting coils, and 1 to 6 for directing current to the holding coils. For convenience, the members 72 and 74 may respectively be called the dial and the terminal board.

Supported on the posts 76 through 82, intermediate the dial and terminal board, are two dielectric contact-carrying disks 84 and 86. Disk 84 is located immediately in back of the dial 72, while disk 86 is spaced somewhat forward of the terminal board 74. Disks 84 and 86, respectively, carry centrally disposed power-supply contact disks S each encircled by a concentric row of twelve insulated spaced contacts which are connected to the terminals, which in turn are connected to the solenoid coils of the switches. The lifting coil contacts are numbered 1L, 2L, 3L, etc., and the holding coil contacts 1, 2, 3, etc.

A shaft 88 has its front and rear bearings at

the centers respectively of the dial 72 and disk 86 and is rotatable to its several positions by a pointer knob 90. A dielectric hub 92 is fastened to the shaft between the disks 84 and 86. At its forward end, this hub carries the brush 94 which bridges electrically from the power-supply contact disk S to any one of the contacts of the circular row on the dielectric disk 84 to which it may be turned when the shaft is rotated by the pointer knob 90. At its rearward end, the hub carries a brush 96 which is angularly spaced 180° from the brush 94. This second brush 96 bridges from the central power-supply contact disk S to one after the other of the contacts of the circular row on the dielectric disk 86 as the shaft is rotated.

Midway between the dielectric disks 84 and 86 is a snap-action mechanism for quickly shifting the brushes 96 and 98 from the contact points upon which they rest to the next, as indicated by the spaces on the dial 72. This snap-action mechanism comprises a cam 100 which, in the instant case, is an integral part of the hub 92 and is formed midway of the length of the hub, having six lobes 102 separated by notches 104.

A frame 106 comprises two side plates 108 spaced by shoulder rivets 110 and has a roller 112 between the plates rotatable on a pin 114. One end of the frame 106 is hinged to the post 76, the free end being swingable about the hinge to seat the roller in any one of the notches 104. An extension spring 116 has one end fastened to a rivet 110 at the free end of the frame, and the other end anchored to the post 80, whereby the roller is yieldably held in the notch in which it is seated. The sextuple switch may be broadly designated by the numeral 115.

Fig. 4 is a schematic illustration of the switch shown in Figs. 2 and 3, the parts shown being the pointer knob 90, shaft 88, dial 72 with indicia 1 to 6 for the several tanks controlled, terminal board 74 with terminals 1 to 6 and 1L to 6L to which the coils of the solenoids are connected, and dielectric disks 84 and 86 with power-supply contact disks S and contacts 1 to 6 and 1L to 6L for selectively directing current to the several terminals. Brushes 94 and 96 are shown in that position in which they connect contact disks S to contacts 1. It should be noted (1) that terminal 1 on disk 84 is diametrically opposite terminal 1 on disk 86; (2) that corresponding terminals on disk 84, disk 86, and board 74 are joined by electrical conductors; and (3) that the terminals on the disk 84 progress in the order 1-2L-2-3L-3, etc., while those on the disk 86 progress in the order 1-1L-2-2L-3, etc. This arrangement accomplishes a particular purpose and constitutes one of the important features of the invention, the operation of which is as follows:

When the pointer knob 90 points to 1, as seen in Fig. 4, current will flow from the power supply S of terminal board 74 through the conductor running to S of disk 86, across the brush 96 to the contact 1 and through a conductor to 1 on the terminal board 74 to which the coil 50 of the valve 75 of tank 1 (not shown), is connected, whereby valve 75 of tank 1 is open.

If now, with the pointer knob 90, the switch 115 is snapped to the position 2, current will flow from the power supply S of terminal board 74 through the conductor running to S of disk 86, across the brush 96 to the contact 2 and through a conductor to 2 on the terminal board 74 to which the coil 50 of the valve 75 of tank 2 (not shown) is connected.

But while the brushes 94 and 96 moved from the contacts 1 to the contacts 2 on disks 84 and 86, they crossed and momentarily rested on intermediate contacts 2L on disk 84 and 1L on disk 86. Electrification of the contact 1L on the disk 86 which energizes the lifting coil 52 for valve 1, in this case was neither useful nor harmful, since valve 1 was already open, but electrification of the contact 2L on disk 84, which energized the lifting coil 52 for valve 2, raised the valve 2 to open position so that the holding coil 50 which is energized through contact 2 may keep it open.

The operation of the device in turning the pointer knob 90 from 1 to 2 is repeated in turning it from 2 to 3, 3 to 4, etc., and in all these cases the electrification of the intermediate contacts 2L, 3L, etc., on disk 86 is neither useful nor harmful, since they, in each case, energize lifting coils 52 for valves which are already open, but electrification of the intermediate contacts on disk 84 in each case energizes the lifting coils 52 of valves which it is desired to open, and these coils lift the valves so that the corresponding holding coils 50 may maintain them in the open position.

The foregoing described the operation of the device in turning the pointer knob 90 clockwise, but it sometimes becomes desirable to turn this knob counterclockwise, as when turning from 1 to 6. In such case the brush 94 on disk 84 will move on the contacts 1-1L-6 whereby electrification of the contact 1L was neither useful nor harmful, but the brush 96 on the disk 86 moved on the contacts 1-6L-6 whereby the lifting magnet 52 of valve 6 was energized momentarily through the contact 6L before the holding magnet 50 was permanently energized to hold the valve 6 open. From this it will be seen that the disk 84 has its contacts arranged to perform a necessary function when the knob 90 is turned clockwise, while the disk 86 has its contacts arranged to perform the same function when the knob is turned counterclockwise.

Conditions may, of course, arise where it is desirable to provide for clockwise rotation only in the switch which controls the valves. In such case the disk 84 and its contacts are retained and the disk 86 and its contacts are eliminated, the connection then being made as in Fig. 5. With this arrangement the lifting coil of any valve will be energized momentarily before the holding coil of the same valve as long as the switch is rotated clockwise.

Having thus described our invention, we claim:

1. In an electric switch, a common contact adapted for connection to a source of current supply, a series of insulated spaced contacts each adapted for connection to a separate current receiving device, a brush member adapted for bridging from the common contact to the series of contacts one at a time, and a snap action means associated with said brush member operable to cause said brush member to move off one contact member of the series, make instantaneous contact with a second of the series and stop on a third.

2. In a rotary electric switch, a common contact centrally disposed in said switch and adapted for connection to a source of current supply, a circular row of insulated contacts concentrically spaced around said common contact each adapted for connection to a separate current receiving device, a manually rotatable member concentrically positioned in said switch, a brush member carried by said manually rotatable member adapted for bridging from the common contact to the circular row of contacts one at a time, and a snap action means associated with said manually rotatable member operable to cause said brush member to be rotated from engagement with one contact of the circular row, make instantaneous contact with the next contact of the circular row and stop on a third contact.

3. In a rotary electric switch, a terminal board, a contact supporting disc adjacent said terminal board, a common contact centrally disposed on said disc, a terminal on said terminal board in electrical communication with said common contact, a concentric row of insulated contacts carried by said contact supporting disc, a terminal on said terminal board for each contact of said circular row, each contact of said circular row being in electrical communication with its respective terminal, and each terminal being adapted for connection to a separate current receiving device, a manually rotatable member carried by said switch, a brush member rotatable by said manually rotatable member adapted for bridging from the common contact to the circular row of contacts one at a time, and a snap action means associated with said manually rotatable member, operable to cause said brush member to be rotated from engagement with a selected contact of the circular row, make instantaneous contact with the next contact of the circular row and stop on a third contact.

DAVID SAMIRAN,  
GEORGE W. REPLOGLE.

REFERENCES CITED

The following references are of record in the file of this patent:

UNITED STATES PATENTS

Number	Name	Date
709,135	Brown	Sept. 16, 1902
1,038,598	Kellum	Sept. 17, 1912
1,252,312	Warren	Jan. 1, 1918
1,767,058	Eiseman	June 24, 1930
1,888,684	Middleton	Nov. 22, 1932
1,978,737	Bower	Oct. 30, 1934
2,012,492	Arnold	Aug. 27, 1935
2,089,279	Loeffler	Aug. 10, 1937
2,106,054	Leighton	Jan. 18, 1938
2,292,478	Ray	Aug. 11, 1942
2,303,382	Newhouse	Dec. 1, 1942
2,332,909	Fuscaldo	Oct. 30, 1943

OTHER REFERENCES

Ser. No. 303,854, Peterreins (A. P. C.), published May 18, 1943.