



- (51) International Patent Classification:
E21B 7/06 (2006.01)
- (21) International Application Number:
PCT/US2013/066210
- (22) International Filing Date:
22 October 2013 (22.10.2013)
- (25) Filing Language: English
- (26) Publication Language: English
- (30) Priority Data:
61/725,900 13 November 2012 (13.11.2012) US
- (71) Applicant (for all designated States except US): **EXXON-MOBIL UPSTREAM RESEARCH COMPANY** [US/US]; CORP-URC-SW359, P.O. Box 2189, Houston, TX 77252-2189 (US).
- (72) Inventors; and
- (71) Applicants (for US only): **WANG, Lei** [CN/US]; 8 Nightfall Pl., The Woodlands, TX 77381 (US). **BAILEY, Jef-**

frey, R. [US/US]; 3850 Olympia Dr., Houston, TX 77019 (US). **O'DONNELL, Brian, J.** [US/US]; 3805 Audley St. Apt 25304, Houston, TX 77098 (US). **CHANG, Dar-Lon** [US/US]; 5303 Riverstone Crossing Dr., Sugar Land, TX 77479 (US). **PAYETTE, Gregory, S.** [US/US]; 3279 Las Palmas, Houston, TX 77027 (US).

(74) Agents: **JAMES, Rick, F.** et al.; ExxonMobil Upstream Research Company, CORP-URC-SW359, P.O. Box 2189, Houston, TX 77252-2189 (US).

(81) Designated States (unless otherwise indicated, for every kind of national protection available): AE, AG, AL, AM, AO, AT, AU, AZ, BA, BB, BG, BH, BN, BR, BW, BY, BZ, CA, CH, CL, CN, CO, CR, CU, CZ, DE, DK, DM, DO, DZ, EC, EE, EG, ES, FI, GB, GD, GE, GH, GM, GT, HN, HR, HU, ID, IL, IN, IR, IS, JP, KE, KG, KN, KP, KR, KZ, LA, LC, LK, LR, LS, LT, LU, LY, MA, MD, ME, MG, MK, MN, MW, MX, MY, MZ, NA, NG, NI, NO, NZ, OM, PA, PE, PG, PH, PL, PT, QA, RO, RS, RU, RW, SA, SC, SD, SE, SG, SK, SL, SM, ST, SV, SY, TH, TJ, TM,

[Continued on next page]

(54) Title: METHOD TO DETECT DRILLING DYSFUNCTIONS

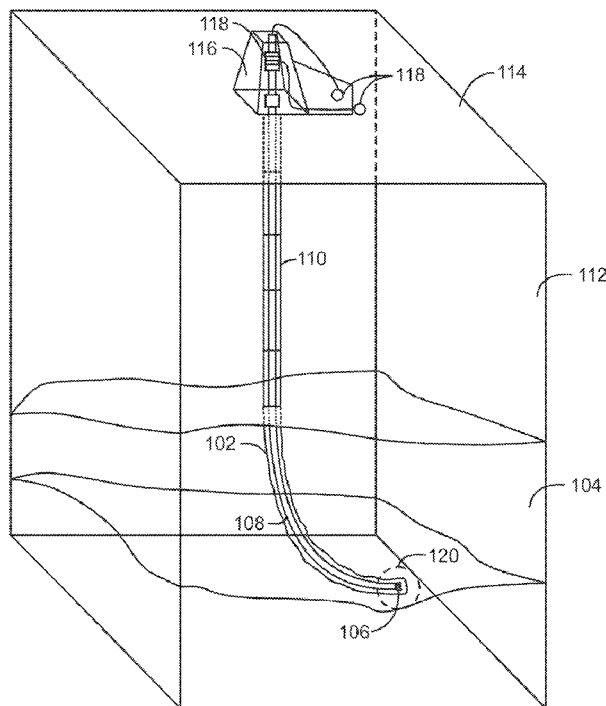

100
FIG. 1

(57) Abstract: Methods and systems for detecting downhole bit dysfunction in a drill bit penetrating a subterranean formation comprising receiving a plurality of drilling parameters characterizing a wellbore drilling operation and calculating bit aggressiveness (μ) at each of a plurality of points during drilling, wherein each point corresponds to time, depth, or both. A depth-of-cut (DOC), time derivative of bit aggressiveness (μ), calculated as $d\mu/dt$, or both, is calculated at each of the plurality of points. A two-dimensional data representation of the plurality of points, comprising μ in one dimension and DOC, $\dot{\mu}$, or both, in another dimension is created. Data features are extracted from the two-dimensional data representation and downhole bit dysfunction is identified by comparing the extracted data features with predefined criteria.





TN, TR, TT, TZ, UA, UG, US, UZ, VC, VN, ZA, ZM, ZW.

(84) Designated States (unless otherwise indicated, for every kind of regional protection available): ARIPO (BW, GH, GM, KE, LR, LS, MW, MZ, NA, RW, SD, SL, SZ, TZ, UG, ZM, ZW), Eurasian (AM, AZ, BY, KG, KZ, RU, TJ, TM), European (AL, AT, BE, BG, CH, CY, CZ, DE, DK, EE, ES, FI, FR, GB, GR, HR, HU, IE, IS, IT, LT, LU, LV, MC, MK, MT, NL, NO, PL, PT, RO, RS, SE, SI, SK, SM, TR), OAPI (BF, BJ, CF, CG, CI, CM, GA, GN, GQ, GW, KM, ML, MR, NE, SN, TD, TG).

— as to the applicant's entitlement to claim the priority of the earlier application (Rule 4.17(iii))

Published:

— with international search report (Art. 21(3))

— before the expiration of the time limit for amending the claims and to be republished in the event of receipt of amendments (Rule 48.2(h))

(88) Date of publication of the international search report:

10 July 2014

Declarations under Rule 4.17:

— as to applicant's entitlement to apply for and be granted a patent (Rule 4.17(ii))

INTERNATIONAL SEARCH REPORT

International application No.

PCT/US13/66210

A. CLASSIFICATION OF SUBJECT MATTER IPC(8) - E21B 7/06 (2014.01) USPC - 700/275; 702/9 According to International Patent Classification (IPC) or to both national classification and IPC		
B. FIELDS SEARCHED Minimum documentation searched (classification system followed by classification symbols) IPC(8) Classification(s): E21B 7/06, 47/18, 47/00, 44/00; G05B 19/04 (2014.01) USPC Classification(s): 173/8, 9; 175/24, 26, 107; 700/275; 702/9 Documentation searched other than minimum documentation to the extent that such documents are included in the fields searched Electronic data base consulted during the international search (name of data base and, where practicable, search terms used) MicroPatent (US Granted, US Applications, EP-A, EP-B, WO, JP, DE-G, DE-A, DE-T, DE-U, GB-A, FR-A); Google; Google Scholar; ProQuest; IP.com; keywords: downhole, derivative, time, drill, bit, aggressiveness, friction factor, motor, stickslip, drillstring, torque, flow, mud motor		
C. DOCUMENTS CONSIDERED TO BE RELEVANT		
Category*	Citation of document, with indication, where appropriate, of the relevant passages	Relevant to claim No.
A	US 2012/0123757 A1 (ERTAS M. D. et al.) May 17, 2012; entire document	1-32
A	US 2010/0032210 A1 (TEODORESCU S. G. et al.) Feb. 11, 2010; entire document	1-32
A	US 2009/0250264 A1 (DUPRIEST F. E.) Oct. 8, 2009; entire document	1-32
A	US 2006/0149478 A1 (CALHOUN W. M. et al.) Jul. 6, 2006; entire document	1-32
<input type="checkbox"/> Further documents are listed in the continuation of Box C. <input type="checkbox"/>		
* Special categories of cited documents: "A" document defining the general state of the art which is not considered to be of particular relevance "E" earlier application or patent but published on or after the international filing date "L" document which may throw doubts on priority claim(s) or which is cited to establish the publication date of another citation or other special reason (as specified) "O" document referring to an oral disclosure, use, exhibition or other means "P" document published prior to the international filing date but later than the priority date claimed "T" later document published after the international filing date or priority date and not in conflict with the application but cited to understand the principle or theory underlying the invention "X" document of particular relevance; the claimed invention cannot be considered novel or cannot be considered to involve an inventive step when the document is taken alone "Y" document of particular relevance; the claimed invention cannot be considered to involve an inventive step when the document is combined with one or more other such documents, such combination being obvious to a person skilled in the art "&" document member of the same patent family		
Date of the actual completion of the international search 28 April 2014 (28.04.2014)		Date of mailing of the international search report <div style="font-size: 24pt; font-weight: bold; text-align: center;">19 MAY 2014</div>
Name and mailing address of the ISA/US Mail Stop PCT, Attn: ISA/US, Commissioner for Patents P.O. Box 1450, Alexandria, Virginia 22313-1450 Facsimile No. 571-273-3201		Authorized officer: Shane Thomas PCT Helpdesk: 571-272-4300 PCT OSP: 571-272-7774

INTERNATIONAL SEARCH REPORT

International application No.

PCT/US13/66210

Box No. II Observations where certain claims were found unsearchable (Continuation of item 2 of first sheet)

This international search report has not been established in respect of certain claims under Article 17(2)(a) for the following reasons:

1. Claims Nos.:
because they relate to subject matter not required to be searched by this Authority, namely:

2. Claims Nos.:
because they relate to parts of the international application that do not comply with the prescribed requirements to such an extent that no meaningful international search can be carried out, specifically:

3. Claims Nos.:
because they are dependent claims and are not drafted in accordance with the second and third sentences of Rule 6.4(a).

Box No. III Observations where unity of invention is lacking (Continuation of item 3 of first sheet)

This International Searching Authority found multiple inventions in this international application, as follows:

-Please See Supplemental Page-

1. As all required additional search fees were timely paid by the applicant, this international search report covers all searchable claims.
2. As all searchable claims could be searched without effort justifying additional fees, this Authority did not invite payment of additional fees.
3. As only some of the required additional search fees were timely paid by the applicant, this international search report covers only those claims for which fees were paid, specifically claims Nos.:
4. No required additional search fees were timely paid by the applicant. Consequently, this international search report is restricted to the invention first mentioned in the claims; it is covered by claims Nos.:
1-32

Remark on Protest

- The additional search fees were accompanied by the applicant's protest and, where applicable, the payment of a protest fee.
- The additional search fees were accompanied by the applicant's protest but the applicable protest fee was not paid within the time limit specified in the invitation.
- No protest accompanied the payment of additional search fees.

-***-Continued from Box No. III: Observations where unity of invention is lacking-***-

This application contains the following inventions or groups of inventions which are not so linked as to form a single general inventive concept under PCT Rule 13.1. In order for all inventions to be examined, the appropriate additional examination fees must be paid.

Group I: Claims 1-32 are directed toward a system for detecting a downhole bit dysfunction.

Group II: Claims 33-37 are directed toward a method of automatically determining off-bottom drillstring torque.

The inventions listed as Groups I-II do not relate to a single general inventive concept under PCT Rule 13.1 because, under PCT Rule 13.2, they lack the same or corresponding special technical features for the following reasons.

The special technical features of Group I include a processor; a storage medium comprising computer readable instructions configured to direct the processor to: calculate a bit aggressiveness (IJ) at each of a plurality of points, wherein each point corresponds to at least one of time and depth; calculate a depth-of-cut (DOC), a time derivative of bit aggressiveness (\dot{I}), calculated as dI/dt , or both at each of the plurality of points; generate a two-dimensional data representation of the plurality of points, comprising IJ in one dimension and at least one of DOC and \dot{I} in another dimension; extract data features from the two-dimensional data representation; identify a downhole bit dysfunction by comparing the extracted data features with predefined criteria; and communicate the detected bit dysfunction (which are not present in Group II).

The special technical features of Group II include wherein the plurality of drilling parameters comprise a surface torque, a drillstring rotatory speed in a revolutions per minute (RPM), a weight on bit (WOB), a hole depth, or a bit depth, or any combinations thereof; recording the surface torque as an off-bottom drillstring torque data point if: the bit depth is less than the hole depth; the RPM is within a target range; and the WOB is less than a threshold value; and calculating the off-bottom drillstring torque as a function of depth from a plurality of offbottom drillstring torque data points (which are not present in Group I).

The common technical features of Groups I-II are obtain a plurality of drilling parameters characterizing a wellbore drilling operation.

These common technical features are disclosed by US 2012/0123757 A1 (ERTAS): obtain a plurality of drilling parameters characterizing a wellbore drilling operation (system computer 410 is in communication with representative data storage devices 412, 414, and 416, which may be external hard disk storage devices or any other suitable form of data storage, storing for example, programs, drilling data, and post-drill analysis results (drilling parameters characterizing a wellbore drilling operation); paragraph [0079]).

Because the common technical features are disclosed by Ertas, the inventions are not so linked as to form a single general inventive concept. Therefore, Groups I and II lack unity.