

No. 897,732.

PATENTED SEPT. 1, 1908.

H. GERDES.
GAS HEATING STOVE.
APPLICATION FILED JAN. 21, 1905.

2 SHEETS—SHEET 1.

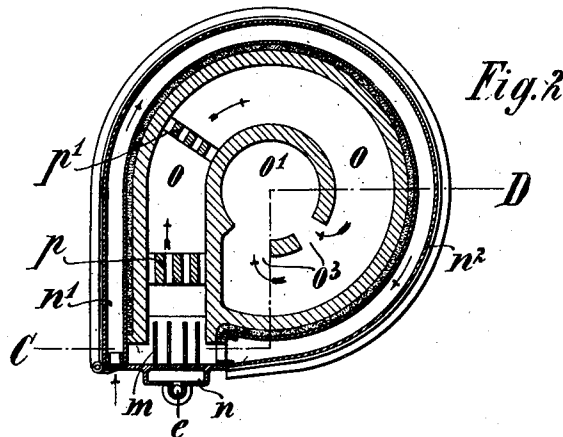
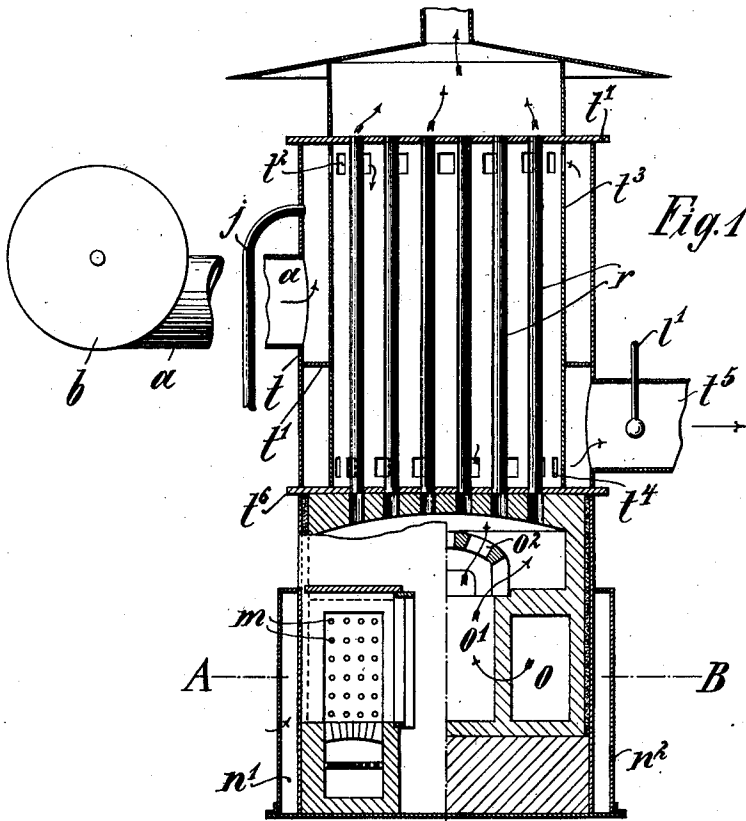

Witnesses:
August M. H. ...
Max K. ...

Inventor:
Heinrich Gerdes
by *Eustace W. Koopman*
Attorney

UNITED STATES PATENT OFFICE.

HEINRICH GERDES, OF BERLIN, GERMANY.

GAS HEATING-STOVE.

No. 897,732.

Specification of Letters Patent.

Patented Sept. 1, 1908.

Application filed January 21, 1905. Serial No. 242,154.

To all whom it may concern:

Be it known that I, HEINRICH GERDES, a subject of the German Emperor, and residing at No. 72-73 Andreasstrasse, Berlin, Germany, have invented new and useful Improvements in Gas Heating-Stoves, of which the following is a description.

The present invention relates to heating stoves for gas heating plants in which a number of stoves are heated from one source such as a generator. In connection with this class of plant, the heating gas employed often contains a considerable proportion of nitrogen and carbon dioxide, and this renders the flame liable to break and go out at times, or the gas may be throttled by the regulating devices employed.

One object of the present invention is to provide a stove in which, if the flame goes out temporarily, it will be subsequently relighted automatically, in that the walls of the combustion chamber are formed of a substance being a bad conductor of heat and will consequently be brought to a glow heat after the flame has been burning a short time, and this glowing surface will serve to immediately relight the flame if it is extinguished, so that no gas will escape.

A further object of the invention is to provide means for controlling the gas fed to the stove by the temperature of the air flowing from the heater, and by the pressure of the air in the stove as hereinafter more particularly set forth.

In order to render the present specification easily intelligible reference is had to the accompanying drawings in which similar letters of reference denote similar parts throughout the several views:—

Figure 1 is a vertical section through the stove, the upper part being taken on the center line and the lower part on the line C—D of Fig. 2. Fig. 2 is a horizontal section on the line A—B of Fig. 1, and Fig. 3 is an elevation of the stove showing the means for regulating the gas feed according to the pressure of the air in the furnace or stove.

The stove is circular in form and provided with a lower hollow fire door *n* having a set of inwardly projecting burner pipes *m* for the gas, which is fed from the supply pipe *e* into the hollow door. The gas issuing from the set of burner pipes *m* burns in the combustion chamber *o* being provided with pre-

heated air along the circular jacket *n'* 55 formed by the mantle *n*², which jacket opens into the combustion chamber *o* at the right hand side of the fire door as shown in Fig. 2. The combustion chamber *o* opens through the orifices *o*³ into the central chamber *o'* and 60 the hot gases pass up through the perforated cover *o*² of the said central chamber and through a series of orifices in the roof of the stove proper into and through the tubes *r* mounted in the air cylinder *t* and extending 65 through the top and bottom plates *t*⁶ and *t*⁷ of the same in which the said tubes are supported. Within the combustion chamber *o*, two or more bridges *p*, *p'* are provided having slots therein through which the gases pass 70 and these bridges as also the walls of the chamber, are of a material which does not readily conduct heat, so that when the burners have been burning for a short time, these parts will be brought to a glow heat, and will 75 relight the burners if for any reason these should be extinguished without the gas being turned off, as may happen in the manner previously explained. The air heater *t* consists of this outer cylinder in which the air inlet *a* 80 and the air outlet *t*⁵ are provided. An inner cylinder *t*³ incloses the pipes *r* and a horizontally disposed partition wall *t'* is provided between the two cylinders extending between 85 the air inlet *a* and the outlet *t*⁵. The inner cylinder is provided with a ring of openings *t*² at the top, and a similar set of openings at the bottom as at *t*⁴ so that the air entering at *a* will first pass upwardly between the two cylinders, then through the orifices *t*² at the 90 top downwardly among the pipes *r* to the lower openings *t*⁴ and out into the room to be heated at *t*⁵.

The air is forced through the stove by means of a ventilator *b* or other suitable appliance. The gases coming through the pipes *r* pass up the chimney in the usual manner.

In order to regulate the gas feed according to the pressure of the air being heated in the 100 stove, the device illustrated in Fig. 3 is provided. The gas feed pipe *e* to the hollow door of the stove joins with the gas main *c* by means of a valve housing *d* in which the end of the gas main *c* is adapted to be closed by a 105 valve *f*. This valve is attached to a bell *h* by means of a rod *g*, extending up through the pipe *l* fixed in the tank *i* at the bottom of the

same and extending up to a point above the level of the liquid in the said tank *i*. The bell *h* is also provided with a downwardly extending cylinder *k* inclosing the pipe *l* and thus forming a closed space beneath the said bell *h* into which a pipe *j* opens up, the other end of which is in communication with the interior of the air heater *t*. The operation of this part of the invention takes place in the following manner:—If the ventilator *b* is not running, there will be no air pressure in the stove, and consequently none will be communicated to the bell *h* through the pipe *j*, and the valve *f* will therefore rest down on the end of the main *c*, and cut off the gas feed. As soon as the ventilator is set going, there will be pressure in the stove, and this will be communicated to the bell *h* through the pipe *j*, and will raise the bell and lift the valve *f* off its seat, and allow the gas to pass to the stove as will readily be understood.

In order to control the gas feed by the temperature of the room to be heated, a thermostat is advantageously employed. In the outlet *t'* for the air (Fig. 3) a maximal and a minimal thermometer *l'* is provided, which may be a thermostat of the ordinary construction, the free end of which will move to and from the contacts *x* and *z* at the highest temperatures. The other end of the thermostat is attached to one conductor of an electric circuit the other conductor of which passes to the coils *w* and *v*, the solenoids or armatures of which are connected by suitable connecting rods *u* to the plug of the gas feed cock *s*. Thus according to the temperature in the room the tongue of the thermostatic coil will be moved to the contact *x* or *z* and close the corresponding circuit to the coil *w* or *v* thus opening or closing the gas cock according to the temperature in the room to be heated.

I claim as my invention:—

1. In a gas heating stove, the combination of a hollow fire door, an annular combustion chamber, a series of burner pipes to establish communication between the hollow fire door and the said combustion chamber, a gas feed to the door, and bridges in the combustion chamber of material adapted to be brought to a glow heat when the gas burners are ignited a cylinder mounted above the said combustion chamber and having air inlet and outlet, a series of tubes within said cylinder having their lower ends in open communication with the said combustion chamber and their upper ends leading to a chimney, substantially as described.

2. In a gas heating stove, the combination of a series of gas burner tubes and means for feeding gas to the same, an annular combustion chamber and a central circular compartment to the same into which the gases of combustion flow, means for conducting the

gases of combustion from the said central compartment to a series of pipes, bridges in the combustion chamber of refractory material, a jacket around said annular combustion chamber for conducting the air feed for the combustion into the combustion chamber in order to pre-heat the same substantially as described.

3. In a gas heating stove, the combination of an annular combustion chamber having bridges therein of refractory material, a hollow fire door to the said chamber and means for introducing gas into the same, a series of burner tubes extending from the interior of the fire door to the combustion chamber, a hot air jacket around said chamber opening at one end into the chamber at the side of the fire door and at the other into the open air, a central chamber in communication with the said annular chamber and having a perforated roof, a series of tubes mounted above the said chamber and in communication with the upper part of the same, inner and outer cylinders surrounding the said tubes and means for passing a current of air into the said cylinders and over said tubes from the top to the bottom thereof and then into the room to be heated substantially as described.

4. In a gas heating stove the combination of a combustion chamber and means for feeding gas and air thereto, bridges therein of refractory material adapted to be brought to a glow heat when the gas is burned, means for preheating the air fed to the said chamber, a series of tubes located above said chamber and means for conducting the hot gases from the said chamber through the said tubes, cylinders surrounding the said tubes, adapted to conduct the air to be heated along the said tubes, and means for controlling the gas feed according to the pressure of the air to be heated in the said cylinders substantially as described.

5. In a gas heating stove, the combination of a combustion chamber, means for feeding gas to the same and for feeding pre-heated air also to the same, a series of tubes mounted above the said chamber and in communication therewith and through which the hot gases pass off, a cylinder surrounding the said tubes to conduct the air along the same and discharge it into the room to be heated, means for controlling the gas feed to the stove by the pressure of the air in the stove, consisting of a bell mounted in suitable liquid, a pipe to establish communication between said bell and the stove, a valve mounted in the gas feed main and adapted to throttle the same and means for connecting the said valve with the said bell substantially as described.

6. In a gas heating stove the combination of a combustion chamber and means for feed-

ing gas and preheated air to the same, a series of tubes mounted on the said chamber and in communication therewith, cylinders surrounding the said tubes, means for supplying air to said cylinders and taking it therefrom, means for controlling the gas supply by the pressure of the air in the stove and a thermostat for controlling the gas feed by

the temperature of the air flowing from the heater, substantially as described.

10

In testimony whereof I affix my signature in the presence of two witnesses.

HEINRICH GERDES.

Witnesses:

WOLDEMAR HAUPT,
HENRY HASPER.