



(12) **DEMANDE DE BREVET CANADIEN
CANADIAN PATENT APPLICATION**

(13) **A1**

(86) Date de dépôt PCT/PCT Filing Date: 2016/09/26
(87) Date publication PCT/PCT Publication Date: 2017/04/06
(85) Entrée phase nationale/National Entry: 2018/03/28
(86) N° demande PCT/PCT Application No.: EP 2016/001597
(87) N° publication PCT/PCT Publication No.: 2017/054914
(30) Priorité/Priority: 2015/09/30 (DE20 2015 006 845.6)

(51) Cl.Int./Int.Cl. *A61M 5/20* (2006.01)
(71) Demandeur/Applicant:
HASSELMEIER AG, CH
(72) Inventeur/Inventor:
KEITEL, JOACHIM, DE
(74) Agent: FETHERSTONHAUGH & CO.

(54) Titre : AUTO-INJECTEUR COMPRENANT UN DOSEUR
(54) Title: AUTOINJECTOR WITH METERING DEVICE

Fig. 2

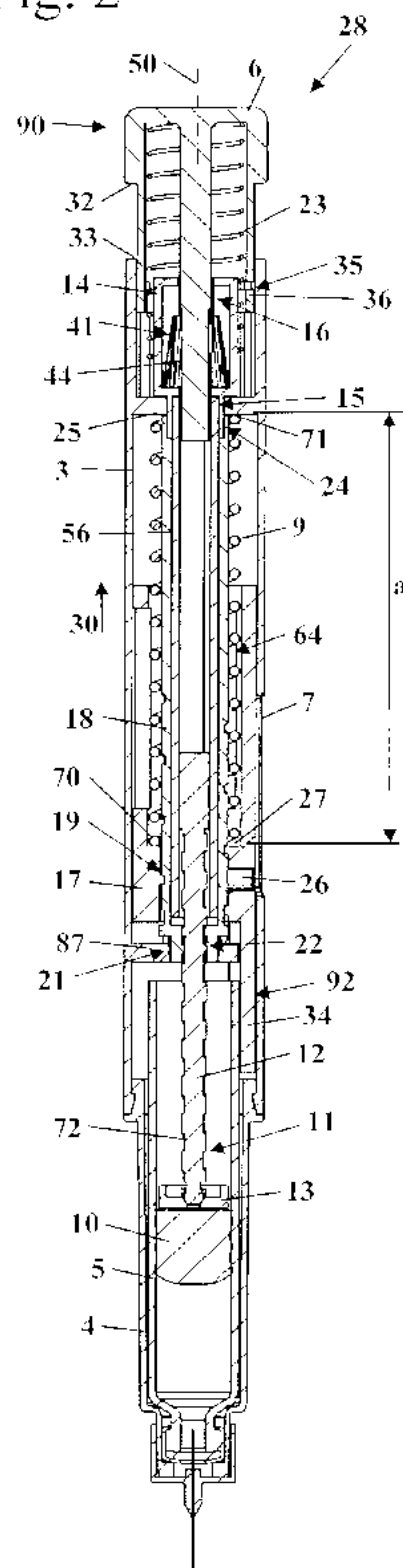

(57) **Abrégé/Abstract:**

The invention relates to an injection device (1, 101) having a housing (2) and a metering element (18) mounted in the housing (2) in a rotatable manner and in a fixed manner in the direction of a central longitudinal axis (50). The metering element (18) is connected via a first threaded connection (19) to an injection sleeve (17), which is rotationally fixed to the housing (2) and is held in a movable manner in the direction of the central longitudinal axis (50). When the injection liquid dose to be ejected is set, the metering element (18) rotates relative to the housing (2), and the injection sleeve (17) moves in the distal direction (30) on the basis

(57) **Abrégé(suite)/Abstract(continued):**

of the first threaded connection (19). When the set injection liquid dose is ejected, the injection sleeve (17) moves in the proximal direction (31), and the metering element (18) rotates in the opposite direction on the basis of the first threaded connection (19). The aim of the invention is to allow an automatic injection of injection liquid. This is achieved in that the injection device (1, 101) has a spring (9), a first end (70) of which is supported on the injection sleeve (17) and a second end (71) of which is supported on the housing (2), and when the injection liquid is ejected, the spring moves the injection sleeve (17) in the proximal direction (31), thereby causing the set injection liquid dose to be ejected.

Abstract

5 An injection apparatus (1, 101) has a housing (2) and a metering member (18) which is held in the housing (2) so as to be rotatable and fixed in the direction of the longitudinal central axis (50). The metering member (18) by way of a first threaded connection (19) is connected to an injection sleeve (17) which is held so as to be rotationally fixed in relation to the housing (2) and displaceable in the direction of the longitudinal central
10 axis (50). When setting a dosage of injection liquid to be squeezed, the metering member (18) rotates in relation to the housing (2), and the injection sleeve (17) by virtue of the first threaded connection (19) moves in the distal direction (30). When squeezing a set dosage of injection liquid, the injection sleeve (17) moves in the proximal direction (31), and the metering member (18) by virtue of the first threaded
15 connection (19) rotates in the opposite direction. In order for an automatic injection of injection liquid to be enabled, it is provided that the injection apparatus (1, 101) has a spring (9) which by way of a first end (70) is supported in relation to the injection sleeve (17) and by way of a second end (71) is supported in relation to the housing (2), and which spring (9), when squeezing injection liquid, moves the injection sleeve (17)
20 in the proximal direction (31), on account thereof causing the set dosage of injection liquid to be squeezed.

(Fig. 2)

Autoinjector with metering device

5 The invention relates to an injection apparatus of the generic type stated in the preamble of claim 1.

An injection apparatus of the generic type is known from WO 2013/117332 A1. The injection apparatus has a metering member which, when setting a dosage of injection
10 liquid to be squeezed, is rotated in relation to the housing. An injection sleeve by way of a first threaded connection moves in the distal direction. The injection sleeve herein moves in the distal direction out of the housing. The operating button that is mounted on the injection sleeve moves conjointly with the injection sleeve in the distal direction. The operator, when squeezing a set dosage of injection liquid, pushes the operating
15 element in the proximal direction and, on account thereof, displaces the injection sleeve in the proximal direction. On account thereof, the metering member by virtue of the first threaded connection rotates in the opposite direction in relation to the housing, causing the injection liquid to be squeezed from a container.

20 The invention is based on the object of achieving an injection apparatus of the generic type, in which the injection is performed automatically.

This object is achieved by an injection apparatus having the features of claim 1.

25 It is provided that the injection apparatus has a spring which by way of a first end is supported in relation to the injection sleeve and by way of a second end is supported in relation to the housing. Accordingly, the spring acts between two components that, when setting a dosage of injection liquid to be squeezed, are moved in relation to one another in the direction of the longitudinal central axis. It is provided that the spring,
30 when squeezing injection liquid, moves the injection sleeve in the proximal direction,

on account thereof causing the set dosage of injection liquid to be squeezed from a container. The threaded connection of the injection sleeve can be conceived such that the injection sleeve has to travel a comparatively great axial distance, and a sufficiently large tensioning distance for tensioning the spring can be guaranteed. The distance by which the injection sleeve moves in the axial direction is capable of being set by way of the conception of the first threaded connection such that an adaptation to the desired tensioning distance is enabled in a simple manner.

The spring is advantageously configured as a compression spring. The spring herein is in particular a compression coil spring. A configuration of the spring as a tension spring, in particular as a tension coil spring, can however also be advantageous. A simple construction results when the spring by way of the first end thereof is supported directly on the injection sleeve, and by way of the second end thereof is supported on the housing. The spring accordingly acts directly between the injection sleeve and the housing. However, it can also be advantageous for the spring to be supported on a component that is connected to the injection sleeve and/or to the housing.

A compact construction is achieved when the metering member is disposed radially within the injection sleeve. The spring is advantageously disposed on the external circumference of the metering member and at least partially in an annular space that is formed between the metering member and the injection sleeve.

In order for a set dosage to be read in a simple manner, it is provided that the housing has a viewing window, and that the injection sleeve has an opening which superposes the viewing window and through which a scale that is disposed on the external circumference of the metering member is visible. In order for an unequivocal display of the set dosage to be achieved even in the case of a large axial distance of the injection apparatus and of a plurality of revolutions of the metering member up to the maximum dosage that can be set, it is provided that the injection sleeve has a portion which at the maximum dosage set covers the proximal region of the viewing window. In order to

achieve a small construction length of the injection apparatus, it is advantageously provided that the portion which covers the proximal region of the viewing window is configured on a web of the injection sleeve which protrudes in the proximal direction. The web herein advantageously extends only in the region of the viewing window, thus
5 not across the entire circumference of the injection apparatus. It is provided that the injection apparatus comprises a container having an injection liquid. In the zero position of the injection apparatus, thus when no quantity of injection liquid to be squeezed has been set, the web advantageously protrudes into the region of the container. A pocket into which the web in the zero position protrudes is advantageously formed in the radial
10 direction between the container and an upper housing part of the injection apparatus. On account of the web and the container mutually overlapping in the axial direction, a comparatively minor construction length of the injection apparatus can be achieved.

The housing advantageously has a housing wall on which a pivot bearing for the
15 metering member is configured. The housing wall advantageously runs so as to be approximately perpendicular to the longitudinal central axis. The web in the zero position advantageously protrudes through a passage opening in the housing wall onto the proximal side of the housing wall. The container is advantageously disposed, and the pocket for the web is advantageously configured, on the proximal side of the
20 housing wall.

It is provided that the injection sleeve in each position of the injection apparatus is disposed completely in the housing of the injection apparatus. A movement of the injection sleeve in the distal direction out of the housing 2 is advantageously not
25 provided.

The injection apparatus advantageously has an operating element which, when setting the dosage of injection liquid to be squeezed, by way of a first coupling is connected in a rotationally fixed manner to the metering member and, when squeezing a set dosage
30 of injection liquid, by way of a second coupling is connected in a rotationally fixed

manner to the housing and is rotatable in relation to the metering member. The operating element, when setting the dosage, is advantageously in a distal terminal position. The operating element, when setting the dosage, is accordingly not moved conjointly with the injection sleeve in the distal direction. In order for the first coupling
5 to be released, the operating element is advantageously to be moved in the proximal direction. Releasing the first coupling herein corresponds to releasing the injection, since the metering member in the case of the released first coupling is rotatable in relation to the operating element and thus in relation to the housing, the spring being able to move the injection sleeve in the proximal direction and herein to rotate the
10 metering member.

A metering piston which by way of a second threaded connection is connected to the metering member is advantageously provided for squeezing injection liquid from the container. The metering piston, when setting the quantity of injection liquid to be
15 squeezed, is advantageously connected in a rotationally fixed manner to the metering member and rotates conjointly with the metering member. The metering piston, when squeezing a quantity of injection liquid to be squeezed, is advantageously connected in a rotationally fixed manner to the housing and by virtue of the second threaded connection moves in the proximal direction. A simple construction of the injection
20 apparatus is achieved on account thereof.

Exemplary embodiments of the invention will be explained hereunder by means of the drawing. In the drawing:

- 25 fig. 1 shows a lateral view of an injection apparatus in the zero position;
- fig. 2 shows a section along the line II-II in fig. 1;
- fig. 3 shows a lateral view of the injection apparatus from fig. 1 in the
30 maximum position;

- fig. 4 shows a section along the line IV-IV in fig. 1;
- 5 fig. 5 shows a perspective illustration of the operating element of the injection apparatus from figs. 1 to 4;
- fig. 6 shows a lateral view of the operating element from fig. 5;
- fig. 7 shows a section along the line VII-VII in fig. 6;
- 10 fig. 8 shows a view of the operating element in the direction of the arrow VIII in fig. 6;
- fig. 9 shows a schematic illustration of a latching web of the operating element;
- 15 fig. 10 shows a schematic perspective illustration of the operating element in two individual parts;
- 20 fig. 11 shows a lateral view of the two individual parts of the operating element;
- fig. 12 shows a lateral view of the entrainment element of the injection apparatus;
- 25 fig. 13 shows a section along the line XIII-XIII in fig. 12;
- fig. 14 shows a section along the line XIV-XIV in fig. 12;
- 30 fig. 15 shows a section along the line XV-XV in fig. 12;

- fig. 16 shows a section along the line XVI-XVI in fig. 12;
- 5 fig. 17 shows a lateral view of the connection element of the injection apparatus;
- fig. 18 shows a section along the line XVIII-XVIII in fig. 17;
- 10 fig. 19 shows a lateral view of a piston rod of the injection apparatus;
- fig. 20 shows a section along the line XX-XX in fig. 19;
- fig. 21 shows a section along the line XXI-XXI in fig. 19;
- 15 fig. 22 shows a lateral view of the operating element and of the entrainment element in a coupling position;
- fig. 23 shows a section along the line XXIII-XXIII in fig. 22;
- 20 fig. 24 shows a lateral view of the operating element and of the entrainment element in a first relative position;
- fig. 25 shows a section along the line XXV-XXV in fig. 24;
- 25 fig. 26 shows a lateral view of the operating element and of the entrainment element in a second relative position;
- fig. 27 shows a section along the line XXVII-XXVII in fig. 26;

- fig. 28 shows a lateral view of the operating element and of the entrainment element in a third relative position;
- fig. 29 shows a section along the line XIX-XIX in fig. 28;
- 5 fig. 30 shows a lateral view of a metering member of the injection apparatus;
- fig. 31 shows a section along the line XXXI-XXXI in fig. 30;
- 10 fig. 32 shows a lateral view of an injection sleeve of the injection apparatus;
- fig. 33 shows a section along the line XXXIII-XXXIII in fig. 32;
- 15 fig. 34 shows a section along the line XXXIV-XXXIV in fig. 32;
- fig. 35 shows a lateral view of an upper housing part of the injection apparatus;
- 20 fig. 36 shows a section along the line XXXVI-XXXVI in fig. 35;
- fig. 37 shows a section along the line XXXVII-XXXVII in fig. 35;
- 25 fig. 38 shows a lateral view in the direction of the arrow XXXVIII in fig. 36;
- fig. 39 shows a lateral view of a further injection apparatus in the zero position;
- 30

- fig. 40 shows a section along the line XL-XL in fig. 39;
- fig. 41 shows the fragment XLI from fig. 40 in an enlarged illustration;
- 5 fig. 42 shows a section along the line XLII-XLII in fig. 41;
- fig. 43 shows a section along the line XLIII-XLIII in fig. 41;
- fig. 44 shows a lateral view of the injection apparatus in a terminal
10 position upon squeezing a set dosage of injection liquid;
- fig. 45 shows a section along the line XLV-XLV in fig. 44;
- fig. 46 shows the fragment XLVI from fig. 45 in an enlarged illustration;
- 15 fig. 47 shows a section along the line XLVII-XLVII in fig. 46;
- fig. 48 shows a section along the line XLVIII-XLVIII in fig. 46;
- 20 figs. 49 and 50 show perspective illustrations of the entrainment element of the injection apparatus;
- fig. 51 shows a lateral view of the entrainment element;
- 25 fig. 52 shows a section along the line LII-LII in fig. 51;
- fig. 53 shows a section along the line LIII-LIII in fig. 51; and
- fig. 54 shows a section along the line LIV-LIV in fig. 51.

Fig. 1 shows an injection apparatus 1 as an exemplary embodiment of a mechanical injection apparatus in which the squeezing of a dosage of injection liquid is performed automatically. The injection apparatus 1 has a housing 2 which comprises an upper housing part 3 and a holder 4 which is secured on an upper housing part 3. The holder 4 is disposed on the proximal side of the upper housing part 3. An injection needle 8 is secured on the proximal side of the holder 4. An operating element 6 is disposed on the distal side of the injection apparatus 1. The operating element 6 by way of a coupling 20 is connectable in a rotationally fixed manner to the upper housing part 3. The upper housing part 3 has a viewing window 7 which is advantageously composed of a transparent material such that an injection sleeve 17 that is disposed in the upper housing part 3 is visible through the viewing window 7. The injection apparatus 1 has a longitudinal central axis 50 which runs in the longitudinal direction of the housing 2 of the injection apparatus 1.

The distal end of the injection apparatus 1 is that end that faces away from an injection needle 8 that is held on the injection apparatus 1. "Proximal" refers to that side of the injection apparatus 1 which in an injection faces the pierced location, and "distal" refers to that side that faces away from the pierced location. The proximal direction describes the injection direction, thus the direction toward the injection needle 8, or the direction in which the injection liquid is squeezed from a container, respectively. The distal direction describes the opposite direction, thus away from the injection needle 8.

Figs. 1 and 2 show the injection apparatus 1 in a zero position 28 at which no dosage of injection liquid is set. The operating element 6 is in the distal terminal position 90 thereof. As is shown in fig. 2, a container 5 having an injection liquid is disposed in the holder 4. A plug 10 is disposed in the container 5, a piston disk 13 of a metering piston 11 bearing on said plug 10. The metering piston 11 moreover comprises a piston rod 12 which supports an external thread 72.

The external side of the injection sleeve 17 is visible through the viewing window 7 of the upper housing part 3. The injection sleeve 17 has an opening 26 through which the external circumference of a metering member 18 that is disposed radially within the injection sleeve 17 is visible. The metering member 18 which can also be referred to as a graduated tube, on the external circumference thereof supports a scale 59 (shown in fig. 30) which is visible to the operator through the viewing window 7 and through the opening 26, and displays the set dosage of injection liquid to be squeezed.

The injection sleeve 17 is held in the upper housing part 3 so as to be displaceable in the direction of the longitudinal central axis 50 and so as to be rotationally fixed in relation to the upper housing part 3. The injection sleeve 17 herein is disposed completely within the housing 2, specifically within the upper housing part 3, in each position of the injection apparatus 1. The metering member 18 and the injection sleeve 17 are interconnected by way of a first threaded connection 19. The metering member 18 is mounted on a pivot bearing 21 so as to be rotatable in the upper housing part 3, and held so as to be axially non-displaceable in the upper housing part 3. The metering member 18 by way of a second threaded connection 22 is connected to the external thread 72 of the piston rod 12.

An entrainment element 14 is mounted in the upper housing part 3. The entrainment element 14 is connected in a rotationally fixed manner to the metering member 18 by way of a rotationally fixed connection 24. The rotationally fixed connection 24 can be a press-fit connection. However, it can also be provided that the rotationally fixed connection 24 is a form-fitting connection. The entrainment element 14 is rotatably mounted on a pivot bearing 15 that is configured in an upper housing part 3. The pivot bearing 15 is formed by a periphery of the upper housing part 3.

As is also shown in fig. 2, a spring 9 which is configured as a compression spring, specifically as a compression coil spring, is disposed in the upper housing part 3. The spring 9 by way of a first end 70 is supported on a bearing periphery 27 of the injection

sleeve 17, and by way of a second end 71 is supported on a bearing periphery 25 of the upper housing part 3. The pivot bearing 15 for the entrainment element 14 is also configured on the bearing periphery 25. The spring 9 is disposed so as to be radially outside the metering member 18, and in the zero position 28 shown in fig. 2, by way of the proximal region of said spring 9, protrudes into an annular space 64 that is formed between the injection sleeve 17 and the metering member 18.

The operating element 6 is connected in a rotationally fixed manner to the piston rod 12 by way of a connection element 56 which is configured as a sleeve, The operating element 6 is supported in relation to the upper housing part 3 by way of a spring 23 which is configured as a compression coil spring. The spring 23, which pushes the operating element 6 in the distal direction, has no influence on the injection rate. The spring 23 is conceived merely such that the operator can activate the operating element 6 by way of a comfortable force. A shoulder 32 which, in the case of an operating element 6 that is pushed in the proximal direction, interacts with a periphery 33 of the upper housing part 3 is configured on the operating element 6, said shoulder 32 conjointly with the periphery 33 forming a detent which delimits the proximal position of the operating element 6. A further detent which can be configured on the entrainment element 14, for example, is advantageously provided for establishing the distal terminal position 90 of the operating element 6. A latching installation 35 which comprises a plurality of latching arms 36, one of which being visible in fig. 2, acts between the operating element 6 and the upper housing part 3. The operating element 6 in the zero position 28 shown in figs. 1 and 2 is coupled in a rotationally fixed manner to the entrainment element 14 by way of a coupling 16. Moreover, a setting device 41 which comprises a multiplicity of latching depressions 44 in the entrainment element 14 is formed between the operating element 6 and the entrainment element 14.

In the case of a non-activated operating element 6, the spring 23 pushes the operating element 6 to the distal terminal position 90 thereof, in which the coupling 20 is opened and the operating element 6 is rotatable in relation to the housing 2. In order to set a

quantity of injection liquid to be squeezed, the operator rotates the operating element 6 about the longitudinal central axis 50. The entrainment element 14 that by way of the coupling 16 is connected in a rotationally fixed manner to the operating element 6 is conjointly rotated herein. The entrainment element 14 by way of a rotationally fixed connection 24 is connected to the metering member 18 which is likewise conjointly rotated. The piston rod 12 by way of the connection element 56 is connected in a rotationally fixed manner to the operating element 6 and is likewise conjointly rotated. The injection sleeve 17, by virtue of the first threaded connection 19 and of the fixing of the injection sleeve 17 in a rotationally fixed manner in the upper housing part 3, is moved in the distal direction 30 in the rotating movement of the metering member 18. The injection sleeve 17, by way of the bearing periphery 27 thereof, herein moves toward the bearing periphery 25 of the spring 9, on account of which the spring 9 is tensioned. The bearing periphery 25 of the housing 2 herein can form a detent for the distal position of the injection sleeve 17, thus also for the maximum dosage that can be set. The axial position of the operating element 6 is not changed when the dosage of injection liquid to be squeezed is set. The length of the annular space 64 has been shortened by virtue of the movement of the injection sleeve 17 in the distal direction.

Figs. 3 and 4 show the injection apparatus 1 in a maximum position 29 at which the maximum dosage is set. The length of the spring 9 has been shortened from the non-tensioned length a, shown in fig. 2, to the tensioned length b, shown in fig. 4. It can also be provided that the spring 9 is pretensioned also in the zero position 28. The injection sleeve 17 can bear on the bearing periphery 25. The spring 9 in the maximum position 29 in the exemplary embodiment is disposed completely in the annular space 64. As is shown in fig. 3, the maximum dosage is visible through the viewing window 7 in the maximum position 29. The injection sleeve 17 has a web 34 which protrudes in the proximal direction and covers the region of the metering member 18 that is visible through the viewing window 7 and that does not display the set dosage. A pocket 92 into which the web 34 in the zero position 28 protrudes is formed in the radial direction between the container 5 and the upper housing part 3. The web 34 herein protrudes

through a housing wall 87 of the upper housing part 3 onto the proximal side of the housing wall 87. The pivot bearing 21 for the metering member 18 is configured on the housing wall 87. The threaded connection 22 between the piston rod 12 and the metering member 18 is also disposed in the region of the housing wall 87.

5

In order for a set quantity of injection liquid to be squeezed, the operator pushes the operating element 6 in the proximal direction 31. On account thereof, webs 38 of the coupling 20 (fig. 1) come to engage with latching elements 85 of the latching installation 35 (fig. 38). On account thereof, the operating element 6 in relation to the upper housing part 3 is fixed in a rotationally fixed manner. At the same time, the coupling 16 by virtue of the axial relative movement of the operating element 6 in relation to the entrainment element 14 is at least partially released such that the entrainment element 14, conjointly with the metering member 18, can rotate about the longitudinal central axis 50. The rotating movement is performed by virtue of the axial force that is exerted by the tensioned spring 9 on the injection sleeve 17, said force causing a rotation of the metering member 18. The rotation is performed by virtue of the threaded connection 19 and of the injection sleeve 17 being guided in a rotationally fixed manner in the housing part 3. The piston rod 12 is connected in a rotationally fixed manner to the upper housing part 3 by way of the connection element 56 and of the operating element 6. Therefore, the second threaded connection 22 in the rotation of the metering member 18 causes a movement of the piston rod 12 in the proximal direction 31. On account thereof, the set quantity of injection liquid is squeezed from the container 5.

25 By virtue of the force stored in the spring 9, the injection is performed automatically upon releasing the coupling 16. The spring 9 is conceived such that the force stored in the spring 9 is sufficient in order for the resistance of the plug 10 to be overcome and for injection liquid to be squeezed from the container 5. The injection apparatus 1 has the setting device 41 in order for the injection rate to be set. The setting device 41
30 influences the torque that is required for rotating the entrainment element 14 in relation

to the operating element 6. The torque required herein depends on the axial position of the operating element 6 in relation to the upper housing part 3 and to the entrainment element 14. This will be explained in yet more detail hereunder.

5 Figs. 5 to 11 show the construction of the operating element 6 in detail. The operating element 6 has an operating portion 55 which protrudes from the upper housing part 3, the operator being able to rotate the operating element 6 or to displace the latter in the proximal direction 31 at said operating portion 55. The operating element 6 has a sleeve portion 49 (shown in figs. 5 and 6) which in the zero position 28 and the maximum
10 position 29 protrudes partially from the upper housing part 32, the webs 38 of the coupling 20 being fixed to said sleeve part 49. The sleeve portion 49 on the proximal end thereof supports a total of three latching arms 36 which at the free end thereof have in each case one latching element 47. This is also shown in fig. 8. The outwardly protruding latching elements 47 by way of the latching arms 36 are mounted so as to be
15 movable in a radially inward manner.

As is also shown in fig. 5, the operating element 6 has a connector 66 which on the external circumference thereof supports two bevels 67 for connecting in a rotationally fixed manner to the connection element 56. As is shown in figs. 17 and 18, the
20 connection element 56, which is configured so as to be sleeve-shaped, on the internal side thereof has corresponding bevels 58 which interact with the bevels 67 of the connector 66 and, on account thereof, interconnect in a rotationally fixed manner the operating element 6 and the connection element 56. As is shown in figs. 19 and 20, the piston rod 12 on a distal end portion 73 supports corresponding bevels 74 in order for
25 the piston rod 12 and the connection element 56 to be connected in a rotationally fixed manner. The external thread 72 of the piston rod 12 is also shown in figs. 19 and 21.

As is shown in figs. 5 and 8, the operating element 6 in the exemplary embodiment has six latching webs 43 which in relation to the longitudinal central axis 50 protrude in a
30 radially outward manner and which conjointly with the latching depressions 44 of the

entrainment element 14 form a latching installation 42 (fig. 25). As is schematically shown in fig. 9, each latching web 43 has a radially outward latching edge 45. The latching edges 45 in the exemplary embodiment are inclined in relation to the longitudinal central axis 50 by an angle α . The angle α is adapted to the desired activation distance between the slowest and the fastest injection rate that can be set, and to the desired difference between the slowest and the fastest injection rate. As is schematically shown in fig. 9, the latching webs 43 are disposed on a pin portion 48 of the operating element 6, said pin portion 48 running within the sleeve portion 49 at a radial spacing from the sleeve portion 49. The connector 66 adjoins the pin portion 48 at the proximal end. The latching webs 43 in the exemplary embodiment are configured so as to be integral to the operating element 6 and are composed of the same material as the operating element 6. However, it can also be advantageous for the latching webs 43 to be configured from another material, for example from an elastomer or a rubber, in order for a desired latching characteristic to be set.

15

As is shown in figures 10 and 11, the operating element 6 is constructed from a first individual part 39 and from a second individual part 40, in order for the production and the assembly to be simplified. The operating element 6 can also be formed from a larger number of individual parts. The individual parts 39 and 40 in the exemplary embodiment are fixedly interconnected at a latching periphery 37 of the first individual part 39.

20

Figs. 12 to 16 show the design of the entrainment element 14 in detail. The entrainment element 14 has a bearing portion 57 having a reduced diameter, by way of which the entrainment element 14 is rotatably mounted in the upper housing part 3. As is shown in fig. 13, the entrainment element 14 in the interior thereof has a conical portion 61 which is disposed in a proximal region, a cylindrical portion 62 adjoining said conical portion 61 on the distal side of the latter. The conical portion 61 and the cylindrical portion 62 are formed by a multiplicity of webs 63 (shown in figs. 14 to 16) which protrude in a radially inward manner from a cylindrical external wall 68 of the entrainment element

30

14. The latching depressions 44 are formed in the circumferential direction between the webs 63. The webs 63 have radially inward counter latching edges 46 which are inclined in relation to the longitudinal central axis 50 by an angle β . The angle β herein is open toward the proximal direction. In particular, the angle β is the same size as the angle α of the latching edges 45 of the latching webs 43.

The webs 63 in the cylindrical portion 62 delimit an interior space 60, the interior diameter h of the latter (shown in fig. 14) being only slightly larger than the external diameter of the pin portion 48. The webs 63 in the radial portion 62 have a radially measured height f_1 that corresponds to approximately the radial extent of the latching webs 43.

Fig. 15 shows a section through the conical portion 61. The radially inward latching edges 46 of the webs 63 in the section plane shown in fig. 15 have a spacing g_1 from the longitudinal central axis 50. The radially measured height f_2 of the webs 63 in the section plane through the conical portion 61 shown in fig. 15 is significantly smaller than the height f_1 in the cylindrical portion 62.

Fig. 16 shows a section through the conical portion 61, adjacent to the proximal end of the interior space 60. The latching edges 46 in this section plane have a spacing g_2 from the longitudinal central axis 50 which is significantly larger than the spacing g_1 . The radially measured height f_3 of the webs 63 in the section plane through the conical portion 61 shown in fig. 15 is significantly smaller than the height f_2 in the distal section plane shown in fig. 15.

Figs. 22 to 29 show the operating element 6 and the entrainment element 14 in different axial relative positions. Figs. 22 and 23 show the operating element 6 and the entrainment element 14 in a coupling position 51. In this position, the operating element 6 and the entrainment element 14 are interconnected in a rotationally fixed manner by way of the coupling 16. The coupling 16 is formed by the webs 63 in the cylindrical

portion 62. The webs 63 protrude up to short of the pin portion 48 and overlap the webs 63 on the distal side thereof in the circumferential direction by an engagement depth o . The engagement depth o is chosen such that the entrainment element 14 and the operating element 6 are interconnected in a rotationally fixed manner. Figs. 23, 25, 27, and 29 herein show sections through the operating element 6 on the distal side of the latching webs 43. The sleeve portion 49 has a proximal end side 65. The proximal end side 65 in the coupling position 51 has a first spacing n_1 , measured from a lower edge 86 of the entrainment element 14 in the direction of the longitudinal central axis 50. The lower edge 86 herein is that edge of the entrainment element 14 that bears on the inwardly protruding periphery of the upper housing part 3.

Figs. 24 and 25 show the operating element 6 and the entrainment element 14 in a first relative position 52, at which the setting device 41 acts between the operating element 6 and the entrainment element 14. The proximal end side 65 of the sleeve portion 49 has a spacing n_2 from the lower edge 86 of the entrainment element 14 which is smaller than the spacing n_1 . As is shown in fig. 25, the latching webs 43 are in the conical portion 61 in which the spacing of the latching edges 46 of the webs 63 from the pin portion 48 and from the longitudinal central axis 50 is reduced. In this relative position, the latching webs 43, on the distal side of the latching webs 43, overlap the webs 63 in the radial direction by a latching depth m_1 . The latching depth m_1 is significantly smaller than the engagement depth o in the coupling position 51. The latching depth m_1 is chosen such that the entrainment element 14 can rotate in relation to the operating element 6 while deforming the latching webs 43.

In order to reach the first relative position 52 from the coupling position 51, the operator has to move the operating element 6 in the proximal direction 31, as is indicated in fig. 24. On account thereof, the operating element 6 is displaced relative to the upper housing part 3, and the webs 38 on the operating element 6 come to engage with a latching mechanism 84 (shown in figs. 36 and 38) on the internal side of the upper housing part 3. The latching mechanism 84 has a multiplicity of latching elements 85

which secure the operating element 6 in a rotationally fixed manner in relation to the external housing part 3. The webs 38, conjointly with the latching mechanism 84, form the coupling 20.

5 In the case of the first relative position 52, shown in figs. 24 and 25, the entrainment element 14 can rotate relative to the upper housing part 3 and relative to the operating element 6 when the energy stored in the spring 9 is sufficient in order for the latching webs 43 to be deformed and for the plug 10 to slide in the proximal direction such that the injection liquid is squeezed from the container 5. However, by virtue of the high
10 torque that is required for rotating the entrainment element 14 in relation to the operating element 6, the squeezing of injection liquid is performed very slowly.

In the second relative position 53, shown in figs. 26 and 27, of the operating element 6 and of the entrainment element 14, the operator has pushed the operating element 6 in
15 the proximal direction 31 further into the upper housing part 3. The proximal end side 65 in this position has a third spacing m_3 from the lower edge 86 of the entrainment element 14. The third spacing m_3 is significantly smaller than the second spacing m_2 . In the movement of the operating element 6 in the proximal direction 31 the latching webs 43 in the conical portion 61 have moved further in the proximal direction, thus in the
20 direction toward an enlarged internal diameter of the conical portion 61. The distal side of the latching webs 43 in the radial direction toward the longitudinal central axis 50 has a minor overlap in relation to the webs 63, such that only a minor latching depth m_2 results. In this position of the setting device 41, the torque required for rotating the entrainment element 14 in relation to the operating element 6 is significantly smaller
25 than in the case of the first relative position 52 shown in figs. 24 and 25. The latching webs 43 have to be only slightly deformed in order for the webs 63 to be overcome and for the next latching position to be reached. On account thereof, an injection at the second relative position shown in figs. 26 and 27 is performed at a higher rate than in the case of the first relative position shown in figs. 24 and 25.

30

Figs. 28 and 29 show the operating element 6 and the entrainment element 14 in a third relative position 54 in which the lower edge 86 has only a very minor fourth spacing n_4 from the proximal end side 65. The operating element 6 is in the proximal terminal position thereof in the third relative position 54, in which the shoulder 32 (shown in fig. 2) bears on the periphery 33 of the upper housing part 3. As is shown in fig. 29, the latching webs 43 in the third relative position 54 in the radial direction have an extremely minor overlap in relation to the webs 63. The latching depth m_3 is minimal. It can also be provided that the latching depth m_3 is zero, such that the latching webs 43 can freely rotate in relation to the webs 63, and the setting device 41 in the third relative position 54 does not slow down the rotation of the entrainment element 14 in relation to the operating element 6. Therefore, the highest possible injection rate results in the third relative position 54. The energy which is required for rotating the entrainment element 14 in relation to the operating element 6 is minor. The injection rate is determined by the force stored in the spring 9 and by the friction forces which act between the mutually moving components.

The angle α of the latching edge 45 of the latching web 43 and the angle β of the latching edge 46 of the web 63 are identical in the exemplary embodiment. On account thereof, the latching depths m_1 , m_2 , m_3 are the same across the entire height c of the latching webs 43. In the case of dissimilar angles α , β , dissimilar latching depths m result in different portions of the latching web 43. The force exerted by the setting device 41 can be influenced by a suitable choice in terms of the design and the number of the latching webs 43.

Figs. 30 and 31 show the metering member 18 in detail. The metering member 18 has an external thread 75 which, conjointly with an internal thread 80 of the injection sleeve 17 (shown in fig. 34), forms the first threaded connection 19. The metering member 18 has a bearing connector 69 by way of which the metering member 18 is rotatably mounted in a bearing opening 82 in the upper housing part 3 (figs. 36 and 37). The metering member 18 has bearing webs 76 which bear on that distal side of the housing

wall 87 that has the bearing opening 82. The friction between the metering member 18 and the upper housing part 3 in the rotating movement of the metering member 18 is reduced. As is shown in fig. 31, an internal thread 77 which, conjointly with the external thread 72 of the piston rod 12, forms the second threaded connection 22 is configured in the bearing connector 69 (fig. 2).

As is shown in fig. 32, the injection sleeve 17 has clearances 78 which serve for reducing the weight. The opening 26 behind which the scale 59 of the metering member 18 (fig. 30) is visible to the operator is also shown in figs. 32 to 34.

10

The injection sleeve 17 on the external circumference thereof has two guide grooves 79 which are disposed so as to be mutually opposite. Corresponding guide webs 81, one of which being visible in fig. 36, are configured in the upper housing part 3. The guide webs 81 protrude into the guide grooves 79 and, on account thereof, guide in a rotationally fixed manner the injection sleeve 17 in the upper housing part 3 so as to be movable in the direction of the longitudinal axis 50.

As is shown in fig. 37, the housing wall 87 beside the bearing opening 82 has a passage opening 83, the web 34 of the injection sleeve 17 protruding through the latter. The web 34 does not extend across the entire circumference of the injection sleeve 17 but only across the circumferential region in which the viewing window 7 is disposed. On account of the web 34, a small construction length of the injection apparatus 1 is achieved at a sufficiently large adjustment range of the metering member 18. The metering member 18 rotates and the injection sleeve 17 is displaced in the axial direction when the dosage is being set. On account thereof, the set dosage is in each case visible through the opening 26.

As is shown in fig. 38, the latching elements 85 of the latching mechanism 84 in the exemplary embodiment are configured so as to be non-symmetrical. The latching elements 85 interact with the latching elements 47 on the operating element 6 (fig. 5). A

30

dosage once set cannot be reduced by virtue of the non-symmetrical configuration of the latching elements. However, a reverse rotation of the operating element 6 for reducing a set dosage can also be possible by way of a corresponding design of the latching elements 65 and of the latching elements 47.

5

Clicking noises on account of the latching elements 47 and 85 are audible when setting a quantity of injection liquid to be squeezed. As the operating element 6 and the upper housing part 3 are interconnected in a rotationally fixed manner when a quantity of injection liquid is being squeezed, the clicking noises of the latching installation 35 are not audible when squeezing injection liquid. Instead, clicking noises of the latching installation 42 of the setting device 41 are audible to the operator when squeezing injection liquid. The latching installation 42 in the first latching position 52 herein generates louder clicking noises at a larger temporal interval. The further the operating element 6 is pushed in the distal direction 31, the quieter the clicking noises and the more rapid the succession of the clicking noises. On account thereof, the injection rate is audible to the operator. The latching elements 85, conjointly with the latching elements 47, form the latching installation 35 when setting the dosage of injection liquid to be squeezed. In the squeezing of injection liquid, the latching elements 85 interact with the webs 38 and, conjointly with the latter, form the coupling 20 and connect the operating element 6 in a rotationally fixed manner to the upper housing part 3.

Figs. 39 to 54 show an exemplary embodiment of an injection apparatus 101, the construction of the latter corresponding substantially to that of the injection apparatus 1 from the preceding figures. Equivalent components are identified by the same reference signs in all figures. The injection apparatus 101 has a housing 2 having a viewing window 7 through which the injection sleeve 17 is visible. The injection apparatus 101 has an operating element 106 that in the zero position 28 shown in figs. 39 and 40 is in a distal terminal position 90. The operating element 6 in this position can be held, for example, by a detent (not shown) that is configured on an entrainment element 114.

30

As is shown in fig. 40, the injection apparatus 101 differs from the injection apparatus 1 substantially in terms of the design of the operating element 106 and of the entrainment element 114. The operating element 106 is pretensioned in the distal terminal position 90 thereof by a spring 23. A detent which is formed by a shoulder 32 of the operating element 106 and by a periphery 33 of the upper housing part 3 is formed between the
5 operating element 106 and the upper housing part 3. A latching installation 35 acts between the operating element 106 and the upper housing part 3. The entrainment element 114 is mounted in the upper housing part 3 by way of a pivot bearing 15. A coupling 116 which in the distal terminal position 90 shown of the operating element
10 106 connects the operating element 106 in a rotationally fixed manner to the entrainment element 114 is formed between the entrainment element 114 and the operating element 106.

Figs. 41 to 43 show the design of the operating element 106 and of the entrainment
15 element 114 in detail. As is shown in fig. 42, the upper housing part 3 in the distal end region thereof has a latching mechanism 84 which is formed by a multiplicity of latching elements 85. When setting a quantity of injection liquid to be squeezed, the operating element 106 is to be rotated in a first rotation direction 88 in relation to the upper housing part 3. The latching elements 47 herein latch into the latching elements
20 85 of the upper housing part 3. Clicking noises that are audible to the operator are created herein. The entrainment element 114 has receptacles 117 which are configured as radially aligned slots, coupling webs 104 of the operating element 106 protruding into said receptacles 117. The coupling webs 104 can be configured so as to correspond to the latching webs 43 of the injection apparatus 1. The coupling webs 104, conjointly
25 with the receptacles 117, form the coupling 116.

As is shown in figs. 41 and 43, an interior space 110 is formed on that proximal side of the portion of the entrainment element 114 that has the receptacles 117, only the connector 66 of the operating element 106 protruding through said interior space 110 in
30 the distal terminal position 90 shown of the operating element 106.

The injection apparatus 101 is shown in a terminal position 102 in figs. 44 and 45. Upon setting a quantity of injection liquid to be squeezed by rotating the operating element 106 in the first rotation direction 88, the operating element 106 was moved in the proximal direction 31 until said operating element 106 came to be in the proximal terminal position 91 thereof shown in figs. 44 and 45. The coupling 116 was released in the proximal movement of the operating element 106, and the entrainment element 114 was released and was able to rotate conjointly with the metering member 18 about the longitudinal central axis 50. The rotating movement was initiated by the energy which was stored in the spring 9 and which moved the injection sleeve 17 in the proximal direction 30. The shoulder 32 of the operating element 106 in the proximal terminal position 91 of the operating element 106 bears on the periphery 33 of the upper housing part 3 and forms the detent for the proximal terminal position 91. The coupling webs 104 of the operating element 106 are disposed in the interior space 110 of the entrainment element 114. As is shown in figs. 46 and 48, the coupling webs 104 can freely rotate in the interior space 110. Upon release of the coupling 116, the entrainment element 114, conjointly with the metering member 18, was able to rotate in the second rotation direction 89, and on account thereof was able to squeeze the set dosage of injection liquid from the container 5.

20

As is shown in fig. 47, the webs 38 of the operating element 106 in the proximal terminal position 91 of the operating element 106 lie between the latching elements 85, and on account thereof connect the operating element 106 in a rotationally fixed manner to the upper housing part 3. The coupling webs 104 are not in the receptacles 117 but are completely in the interior space 110 such that a free rotation is possible. The webs 38, conjointly with the latching elements 85 of the latching mechanism 84, form the coupling 20.

25

Figs. 49 to 54 show the design of the entrainment element 114 in detail. As is shown in fig. 49, the receptacles 117 are configured as radially running slots. The entrainment

30

Figs. 49 to 54 show the design of the entrainment element 114 in detail. As is shown in fig. 49, the receptacles 117 are configured as radially running slots. The entrainment element 114 has a bearing portion 115 by way of which the former is rotatably mounted in the housing wall 87 (fig. 46). As is shown in figs. 49 and 50, the entrainment element 114 in a proximal end region has securing webs 118 which serve for the rotationally fixed connection to the metering member 18. The entrainment element 114 is connected in a form-fitting manner to the metering member 18 by way of the securing webs 118. The entrainment element 114 centrally has an opening 120 through which the connector 66 of the operating element 106 protrudes. As is shown in figs. 52 and 53, the entrainment element 114 has a coupling portion 119 in which the receptacles 117 of the coupling 116 are configured. In the interior space 110 that adjoins the coupling portion 119 on the proximal side, the available internal diameter is chosen to be so large that the coupling webs 104 (fig. 46) can freely rotate in the interior space 110.

15 In the case of the exemplary embodiment of an injection apparatus 101 shown in figs. 39 to 54 the injection rate is not selectable by the operator but is determined by the energy stored in the spring 9, by the viscosity of the injection liquid, by the diameter of the injection needle, and by the friction of the plug 10 in relation to the container 5. In contrast, in the case of the injection apparatus 1 the injection rate can be selected by the operator by way of a respective positioning of the operating element 6.

20

Claims

- 5 1. An injection apparatus having a housing (2) which has a longitudinal central axis (50), having a metering member (18) which is held in the housing (2) so as to be rotatable and fixed in the direction of the longitudinal central axis (50) and which by way of a first threaded connection (19) is connected to an injection sleeve (17) which is held so as to be rotationally fixed in relation to
- 10 the housing (2) and displaceable in the direction of the longitudinal central axis (50), wherein the metering member (18), when setting a dosage of injection liquid to be squeezed, rotates in relation to the housing (2), and the injection sleeve (17) by virtue of the first threaded connection (19) moves in the distal direction (30), and wherein the metering member (18), when squeezing a set
- 15 dosage of injection liquid, rotates in the opposite direction in relation to the housing (2) and the injection sleeve (17) by virtue of the first threaded connection (19) moves in the proximal direction (31), characterized in that the injection apparatus (1) has a spring (9) which by way of a first end (70) is supported in relation to the injection sleeve (17) and by
- 20 way of a second end (71) is supported in relation to the housing (2), and which spring (9), when squeezing injection liquid, moves the injection sleeve (17) in the proximal direction (31), on account thereof causing the set dosage of injection liquid to be squeezed.
- 25 2. The injection apparatus as claimed in claim 1, characterized in that the spring (9) is configured as a compression spring.
3. The injection apparatus as claimed in either of claims 1 and 2,

characterized in that the spring (9) by way of the first end (70) thereof is supported on the injection sleeve (17), and by way of the second end (71) thereof is supported on the housing (2).

- 5 4. The injection apparatus as claimed in one of claims 1 to 3,
characterized in that the metering member (18) is disposed radially within the
injection sleeve (17).
- 10 5. The injection apparatus as claimed in claim 4,
characterized in that the spring (9) is disposed on the external circumference of
the metering member (18) and at least partially in an annular space (64) that is
formed between the metering member (18) and the injection sleeve (17).
- 15 6. The injection apparatus as claimed in either of claims 4 and 5,
characterized in that the housing (2) has a viewing window (7), in that the
injection sleeve (17) has an opening (26) which superposes the viewing
window (7) and through which a scale (59) that is disposed on the external
circumference of the metering member (18) is visible, and in that the injection
sleeve (17) has a portion which at the maximum dosage set covers the proximal
20 region of the viewing window (7).
- 25 7. The injection apparatus as claimed in claim 6,
characterized in that the portion which covers the proximal region of the
viewing window (7) is configured on a web (34) of the injection sleeve (17)
which protrudes in the proximal direction (31).
- 30 8. The injection apparatus as claimed in claim 7,
characterized in that the injection apparatus (1) comprises a container (5)
having an injection liquid, and in that a pocket (92) into which the web (34) in
the zero position (28) of the injection apparatus (1) protrudes is formed in the

radial direction between the container (5) and an upper housing part (3) of the housing (2).

9. The injection apparatus as claimed in either of claims 7 and 8,
5 characterized in that the housing (2) has a housing wall (87) on which a pivot bearing (21) for the metering member (18) is configured, and in that the web (34) protrudes through a passage opening (83) in the housing wall (87) onto the proximal side of the housing wall (87).
- 10 10. The injection apparatus as claimed in one of claims 1 to 9,
characterized in that the injection sleeve (17) in each position of the injection apparatus (1) is disposed completely in the housing (2) of the injection apparatus (1).
- 15 11. The injection apparatus as claimed in one of claims 1 to 10,
characterized in that the injection apparatus (1, 101) has an operating element (6, 106) which, when setting the dosage of injection liquid to be squeezed, by way of a first coupling (16, 116) is connected in a rotationally fixed manner to the metering member (18) and, when squeezing a set dosage of injection liquid,
20 by way of a second coupling (20) is connected in a rotationally fixed manner to the housing (2) and is rotatable in relation to the metering member (18).
12. The injection apparatus as claimed in claim 11,
characterized in that the operating element (6, 106), when setting the dosage, is
25 in a distal terminal position (90) and, in order for the first coupling (16, 116) to be released, is to be moved in the proximal direction (31).
13. The injection apparatus as claimed in one of claims 1 to 12,
characterized in that the injection apparatus (1, 101) has a metering piston (11)
30 for squeezing injection liquid from the container (5), wherein the metering

Fig. 1

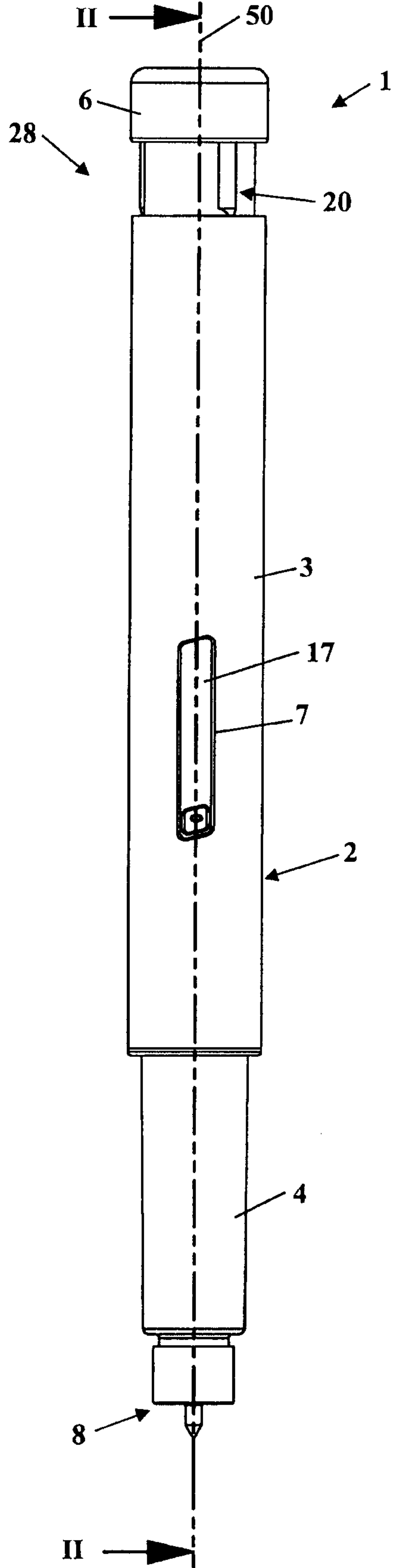

Fig. 2

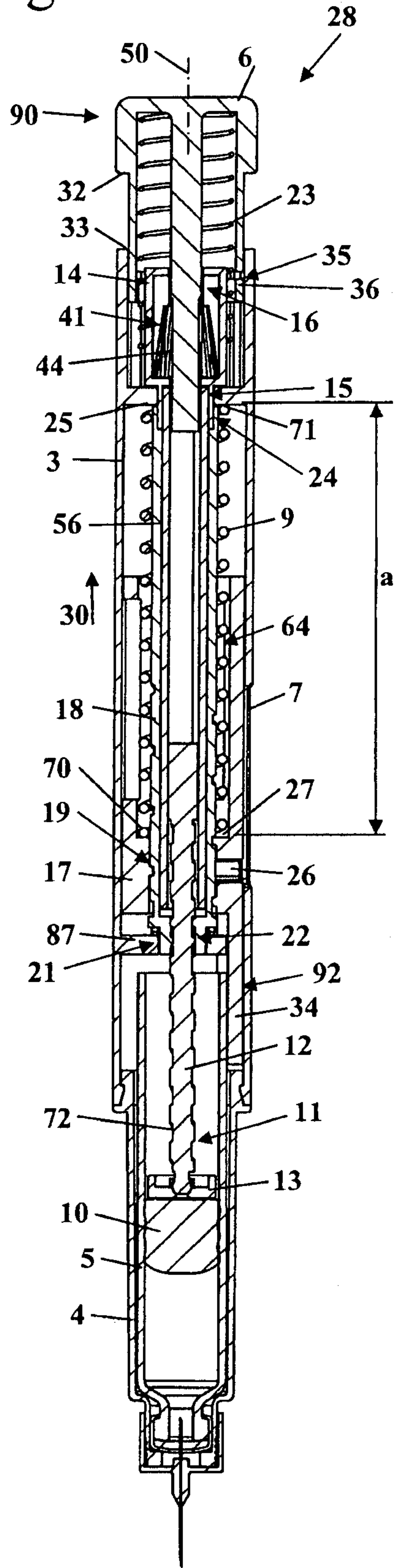

Fig. 3

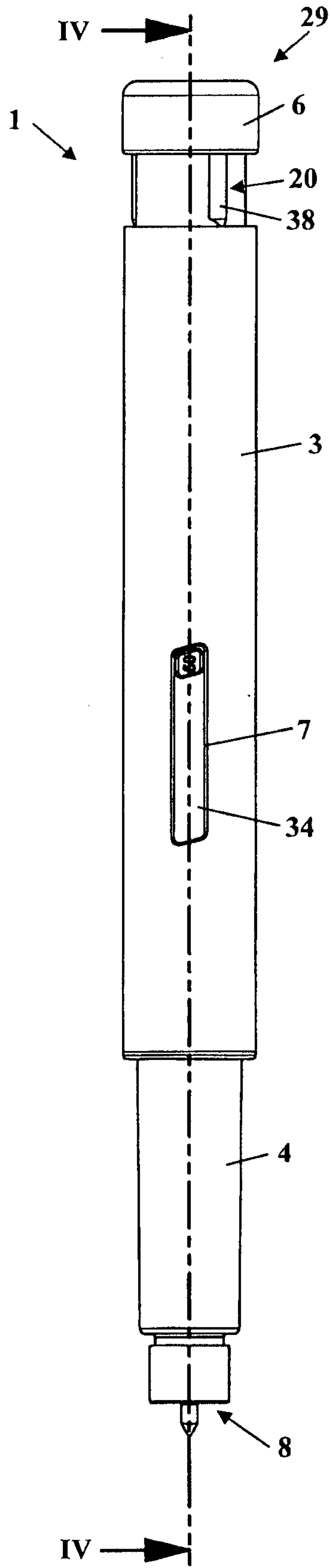

Fig. 4

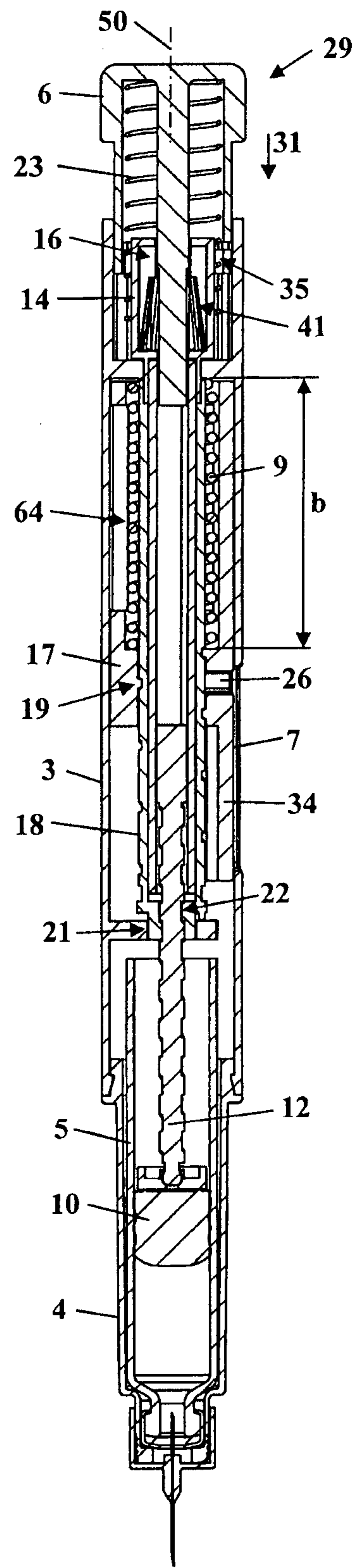

Fig. 5

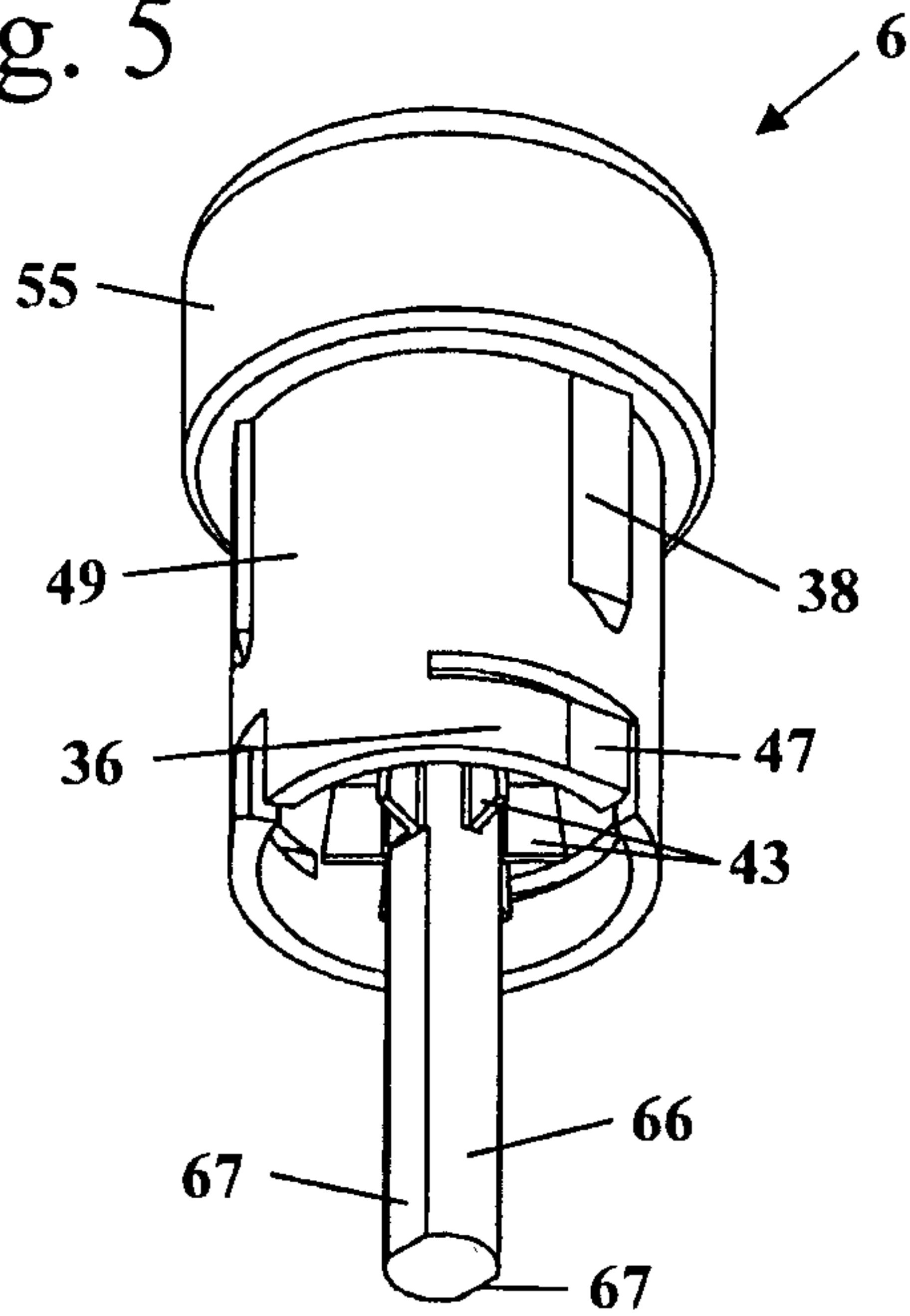

Fig. 6

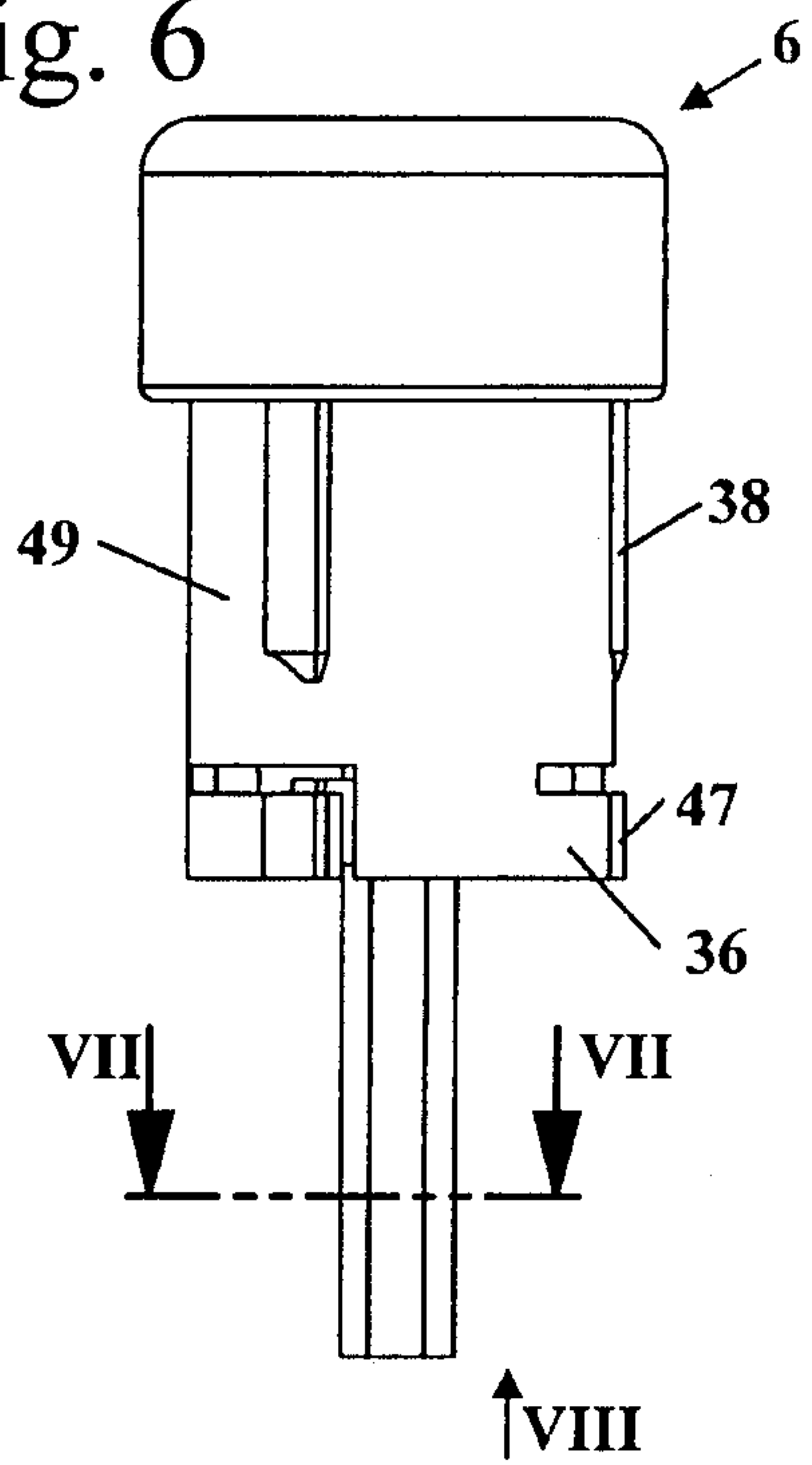

Fig. 8

Fig. 7

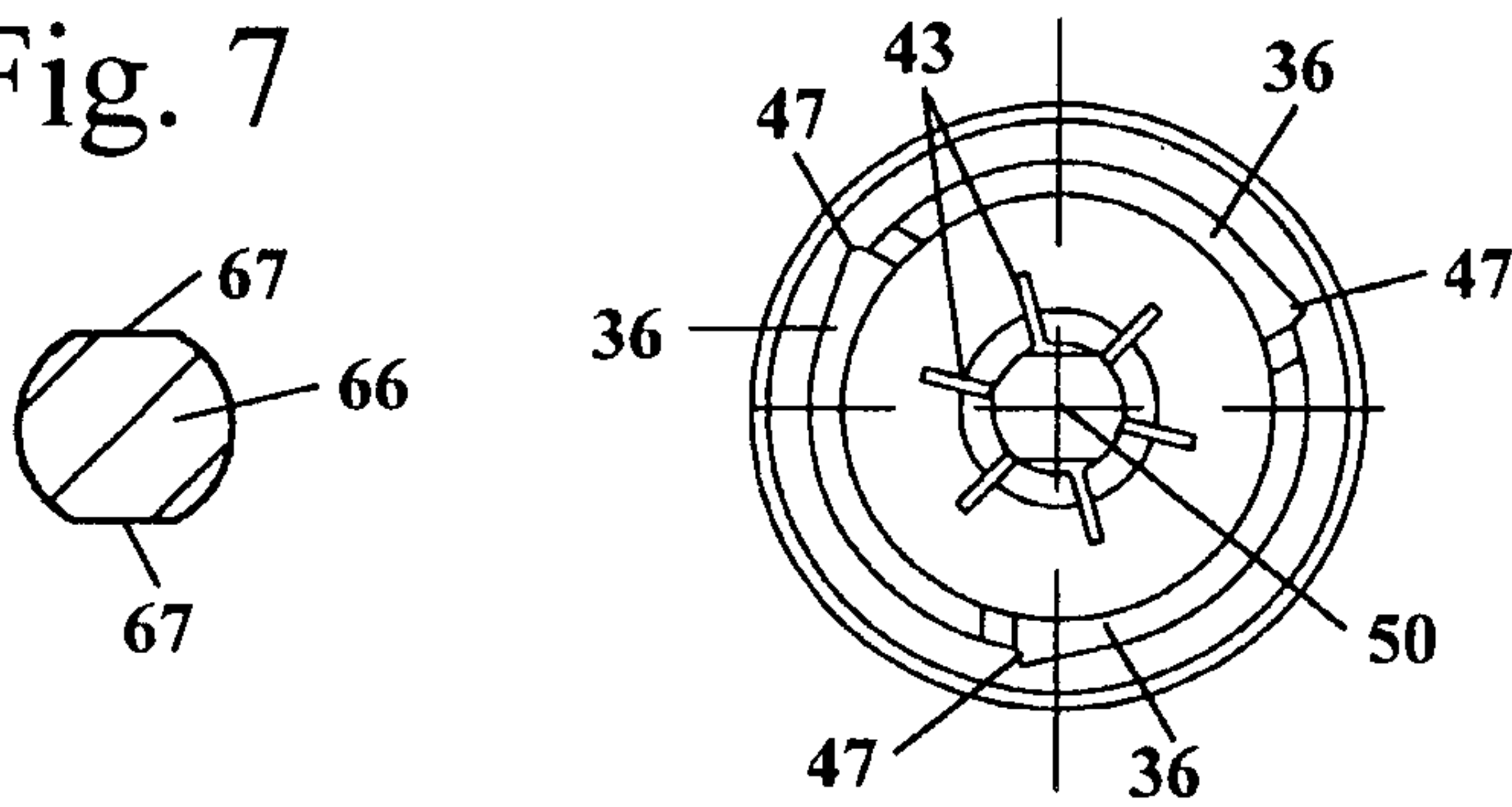

Fig. 9

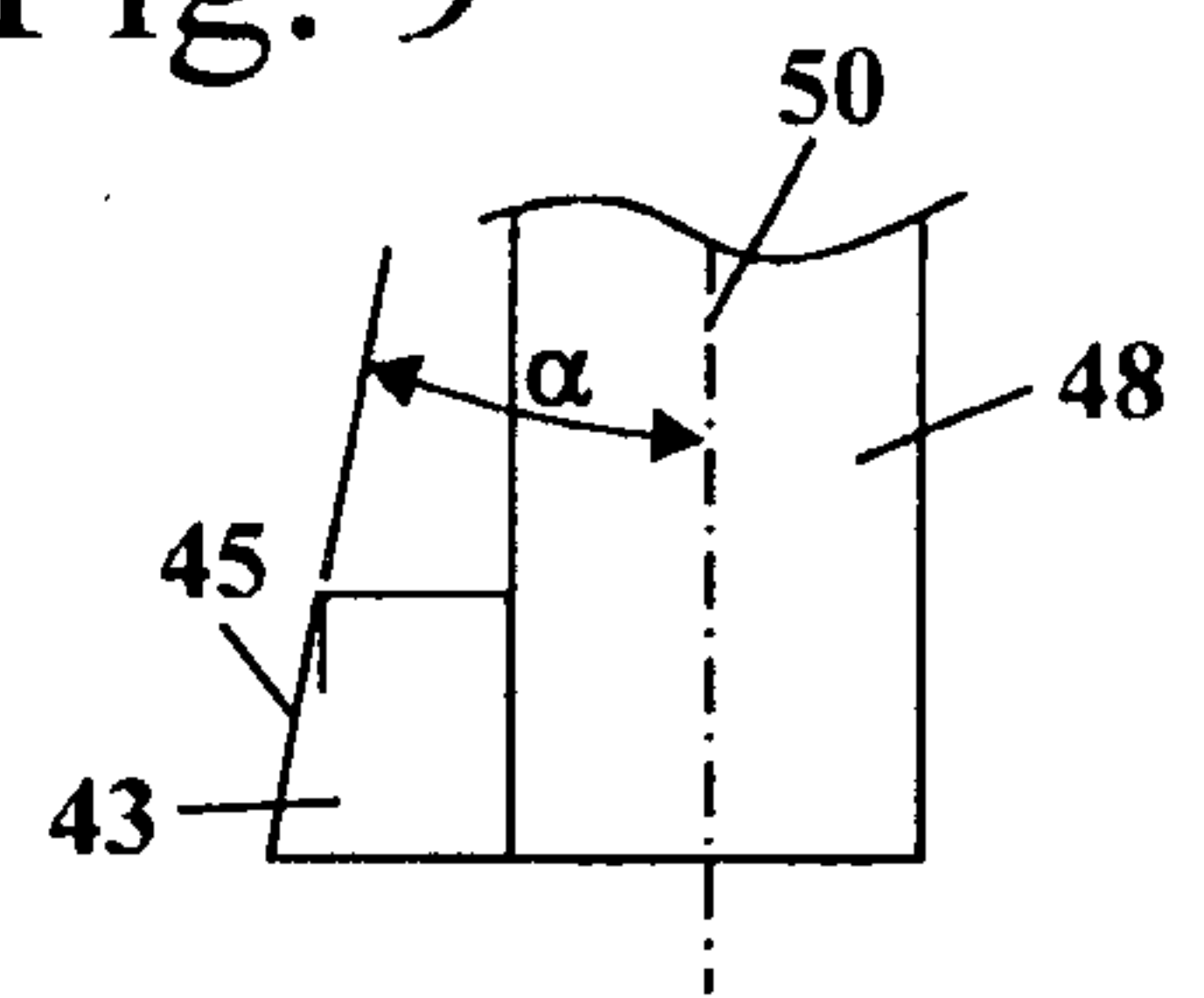

Fig. 10

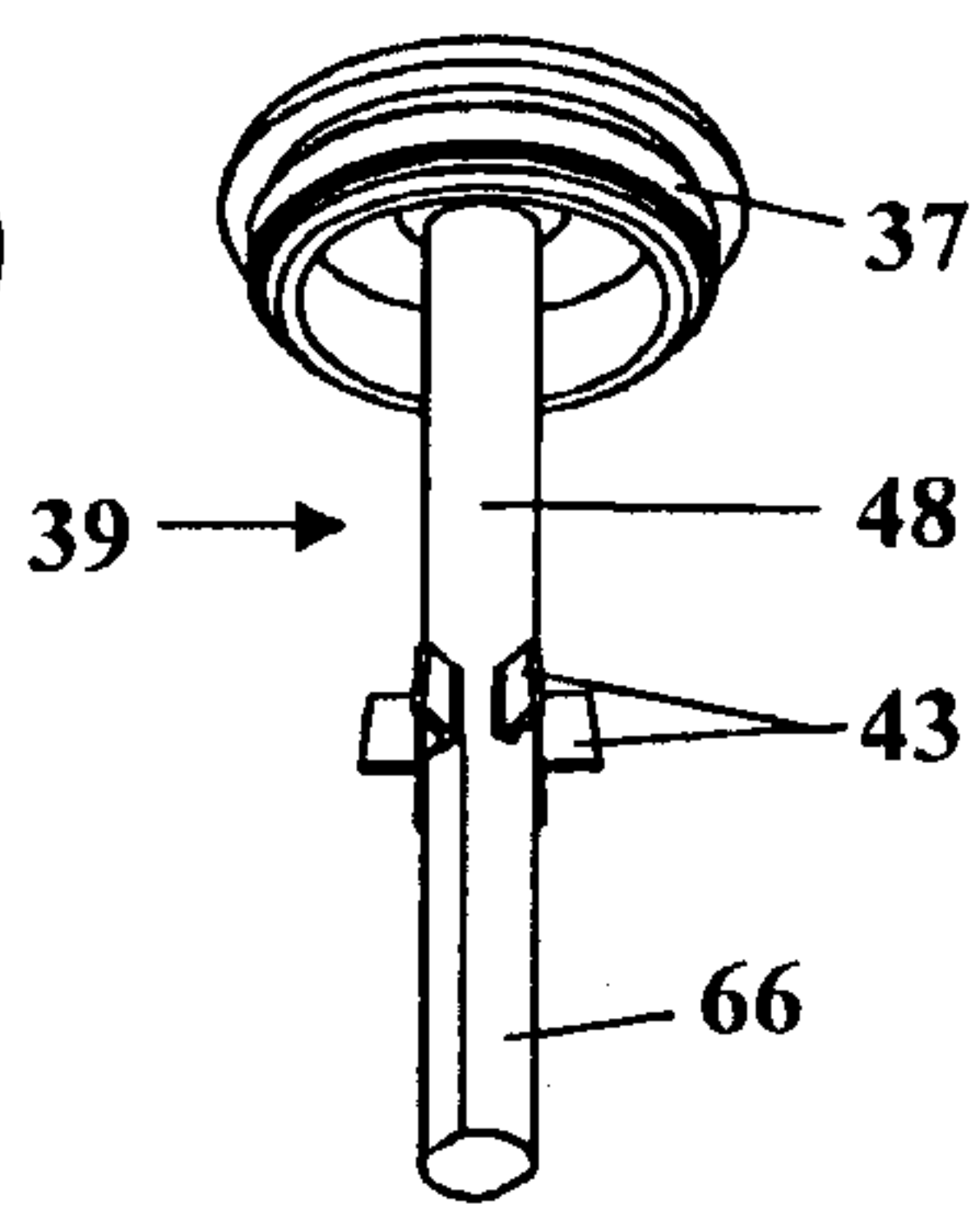

Fig. 11

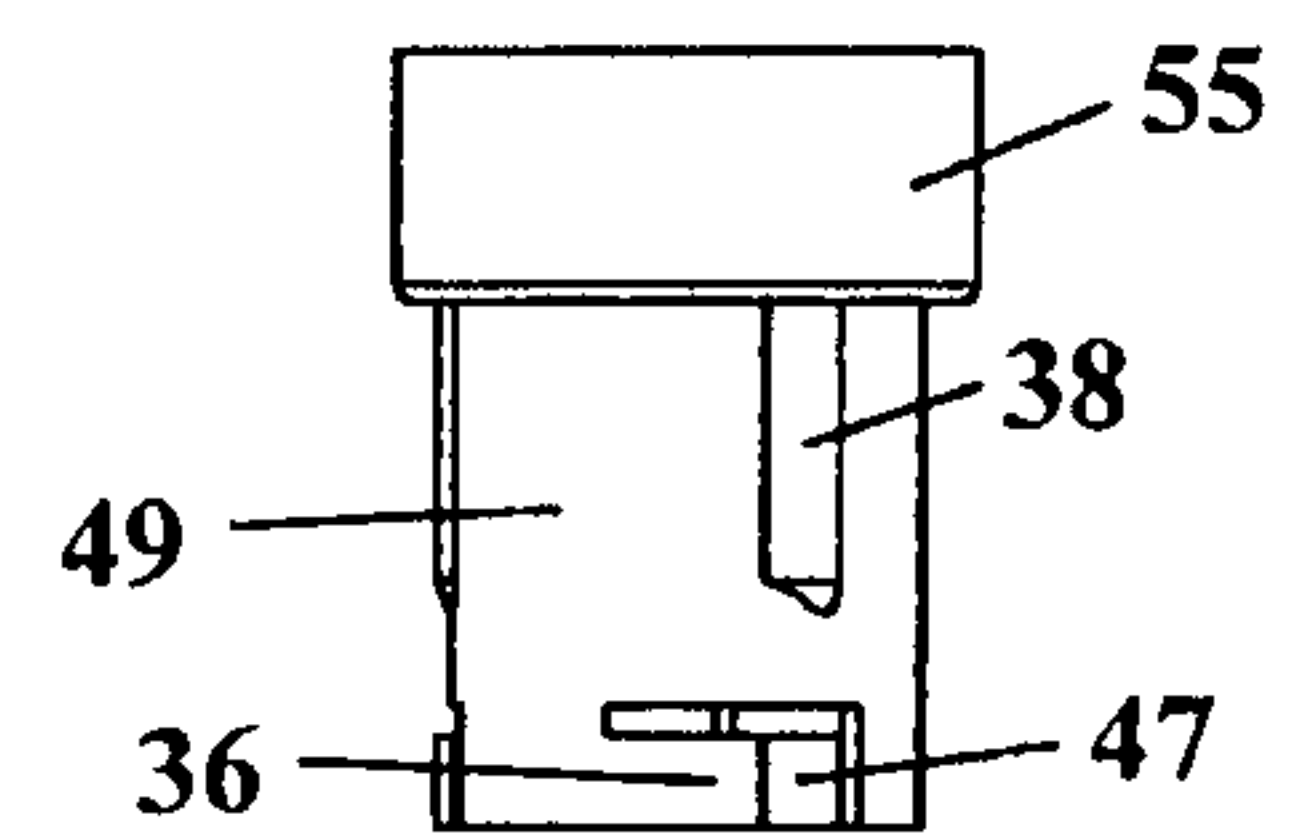
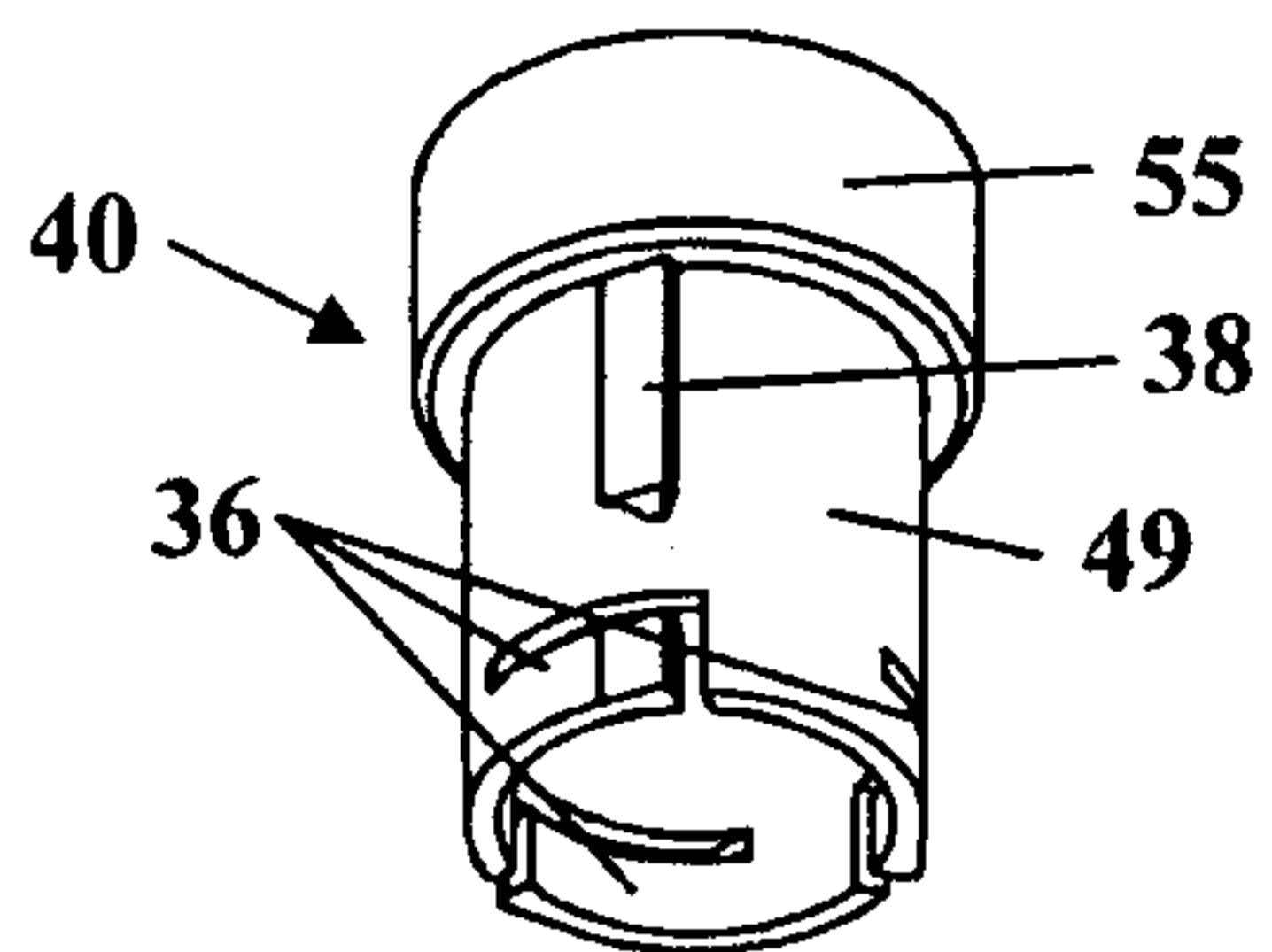
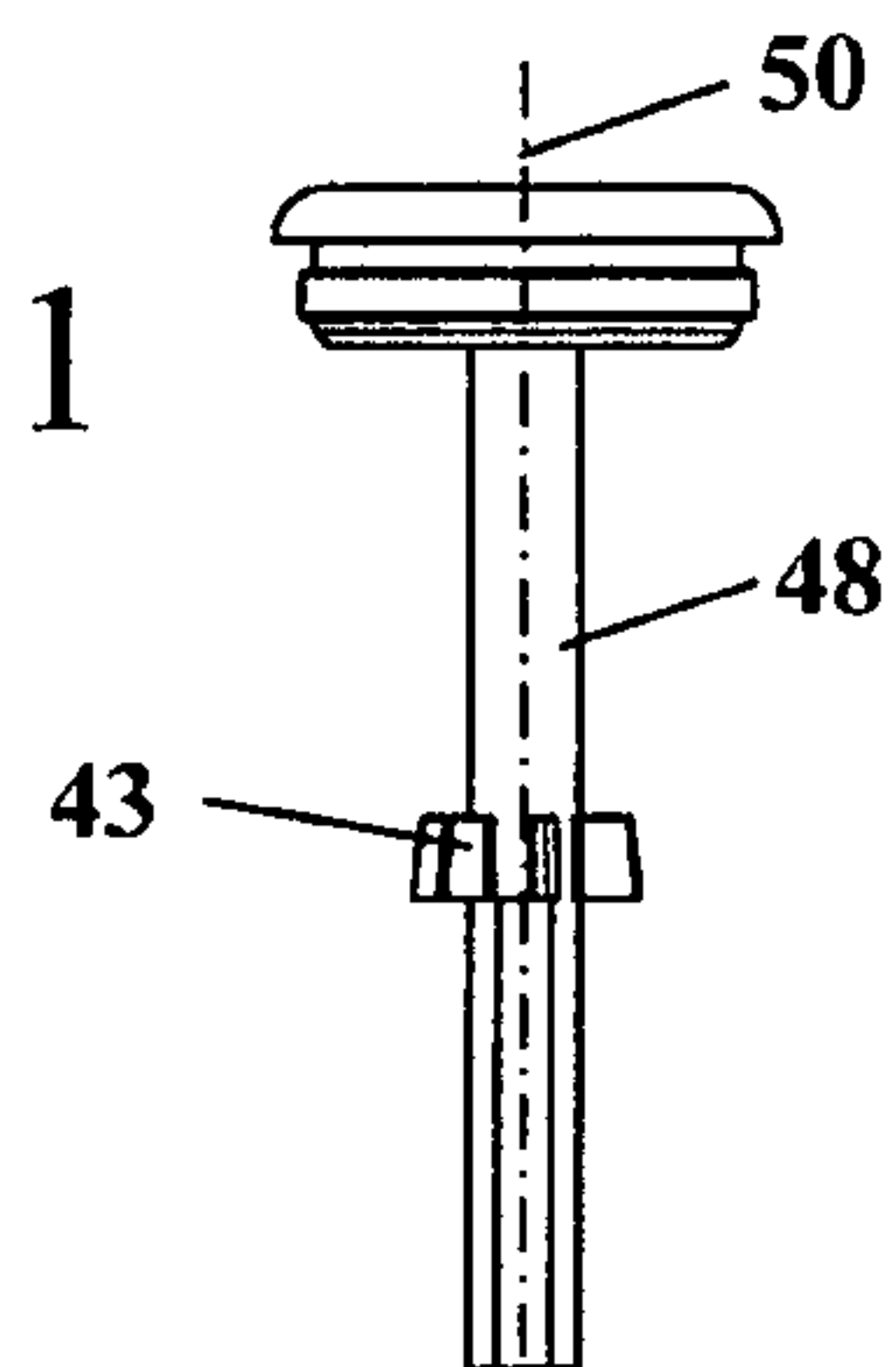

Fig. 12

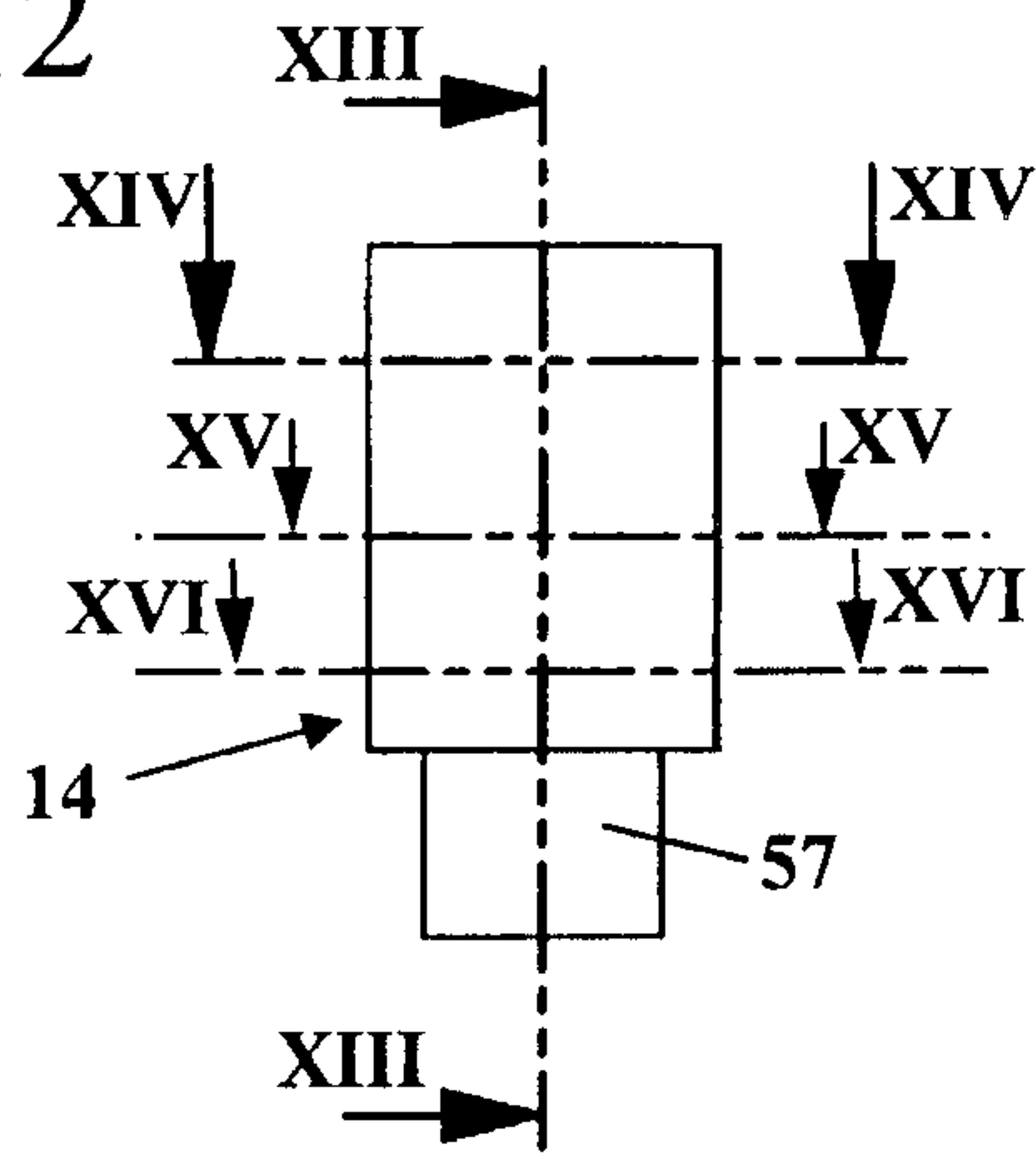

Fig. 13

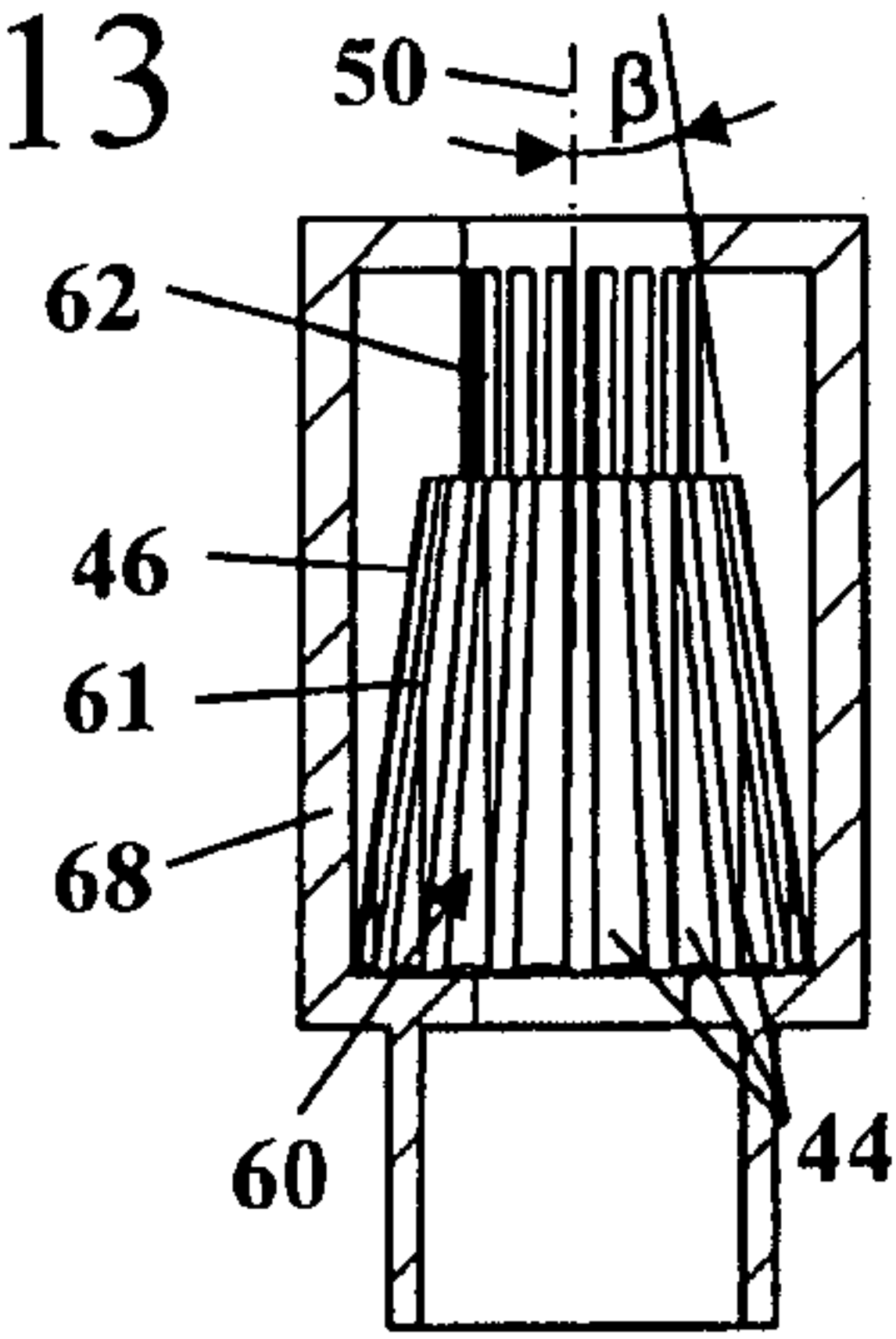

Fig. 14

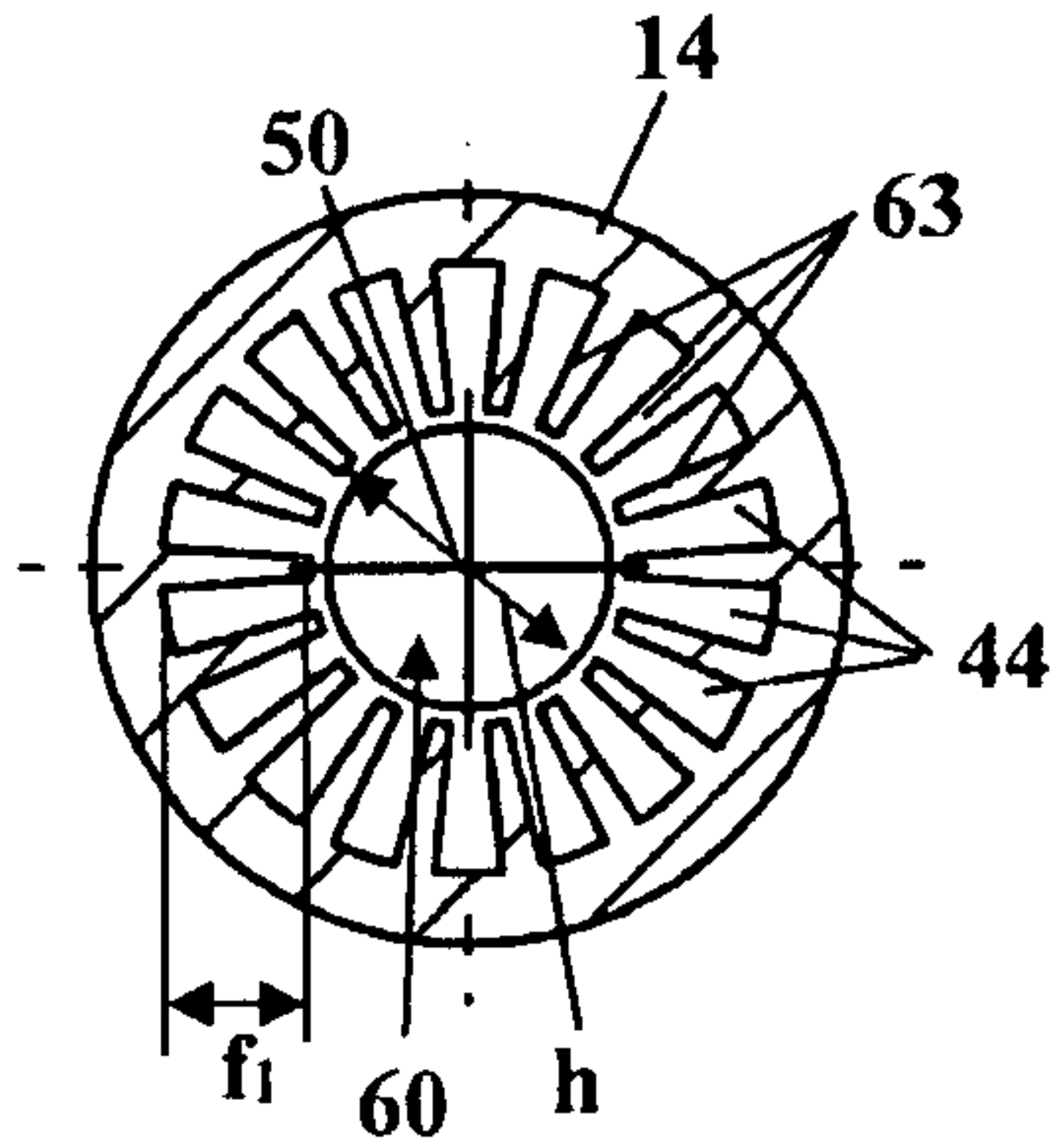

Fig. 15

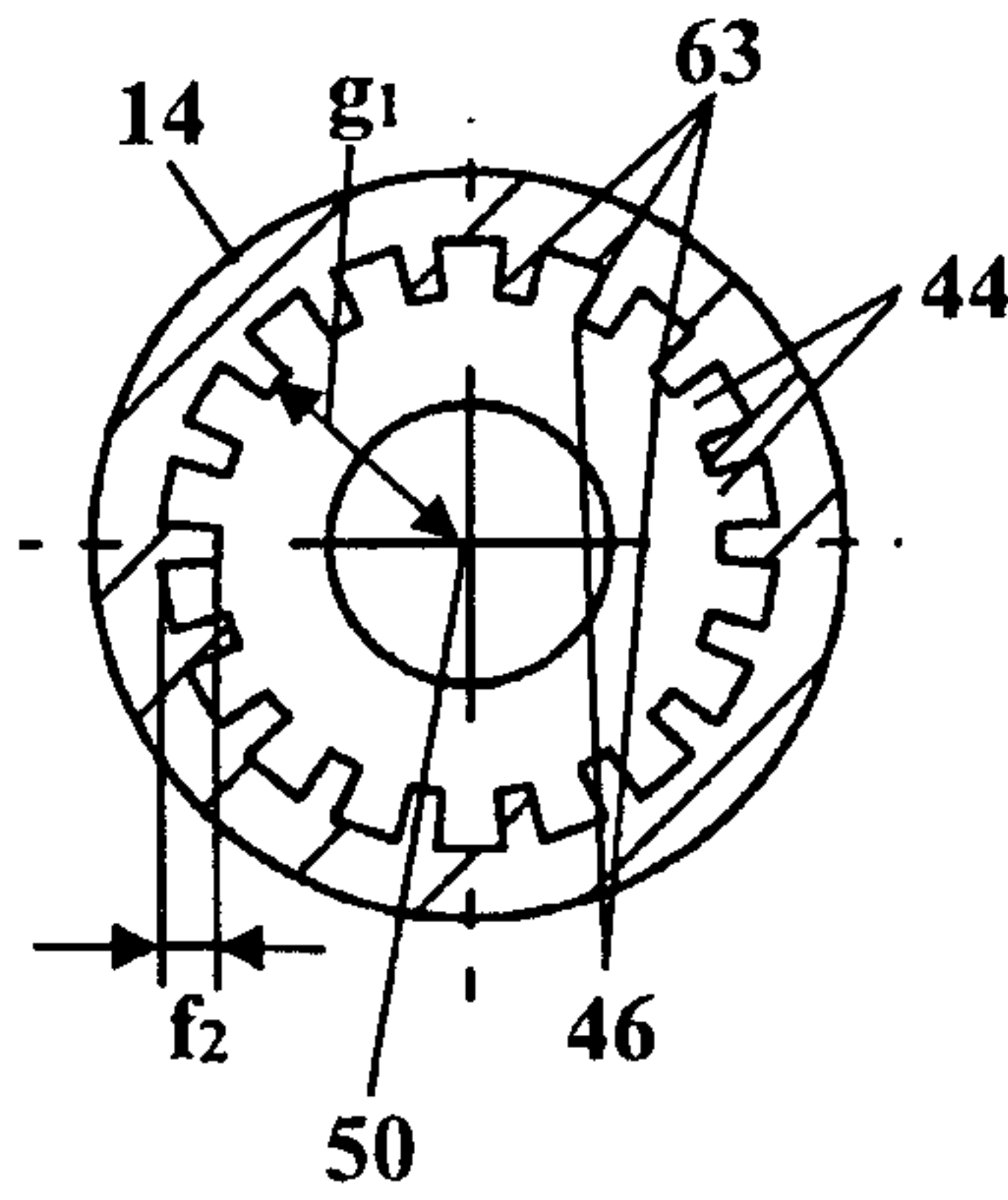

Fig. 16

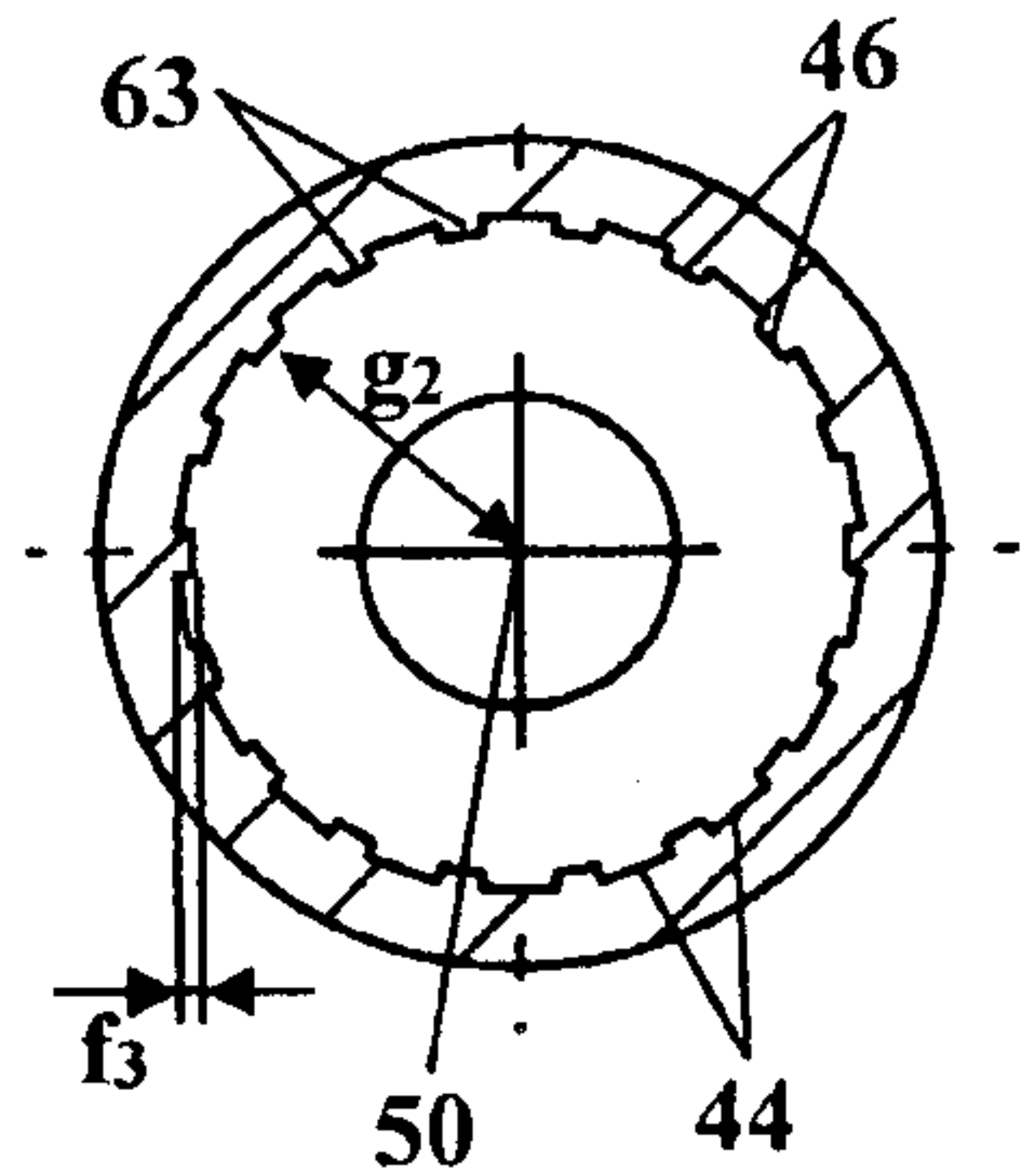

Fig. 17

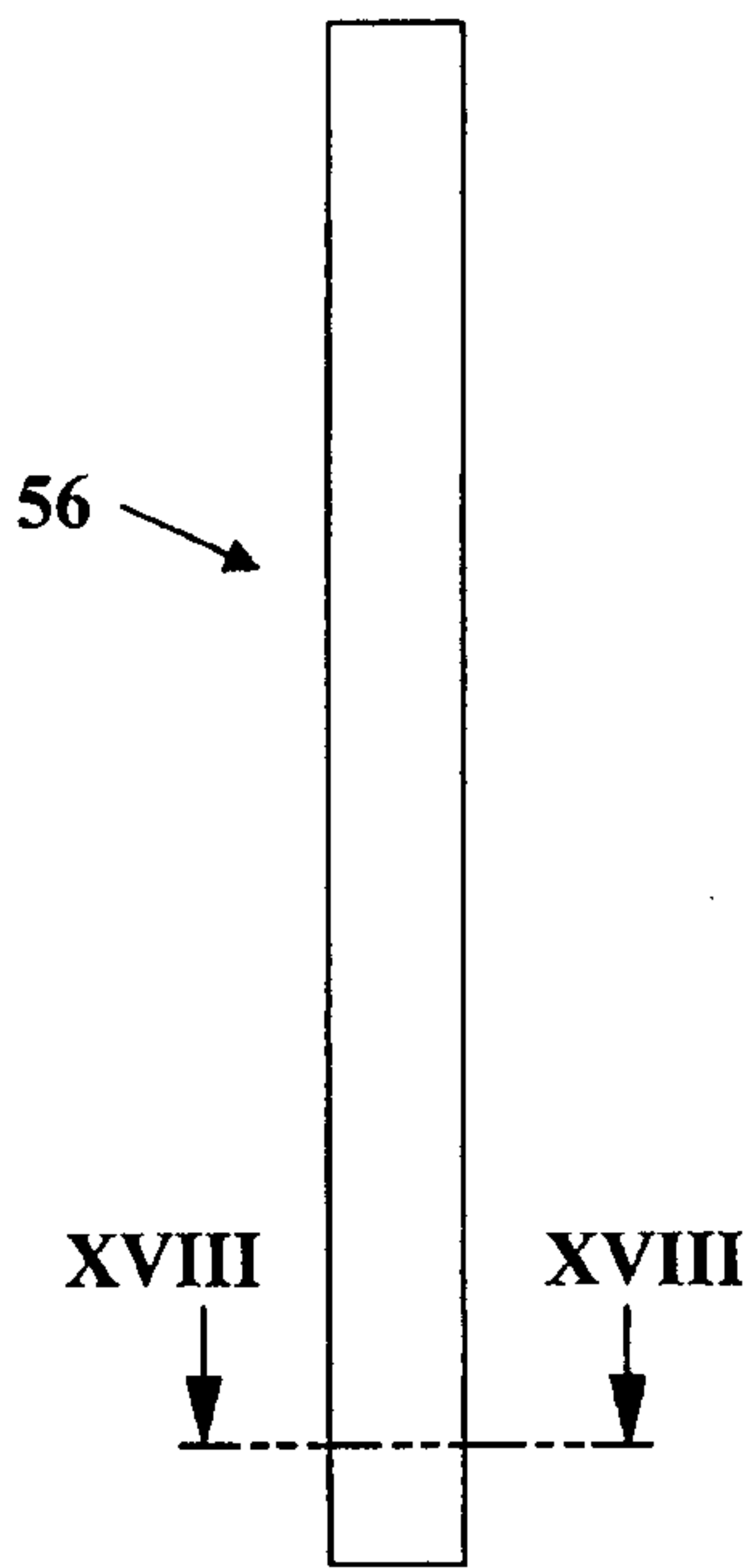

Fig. 18

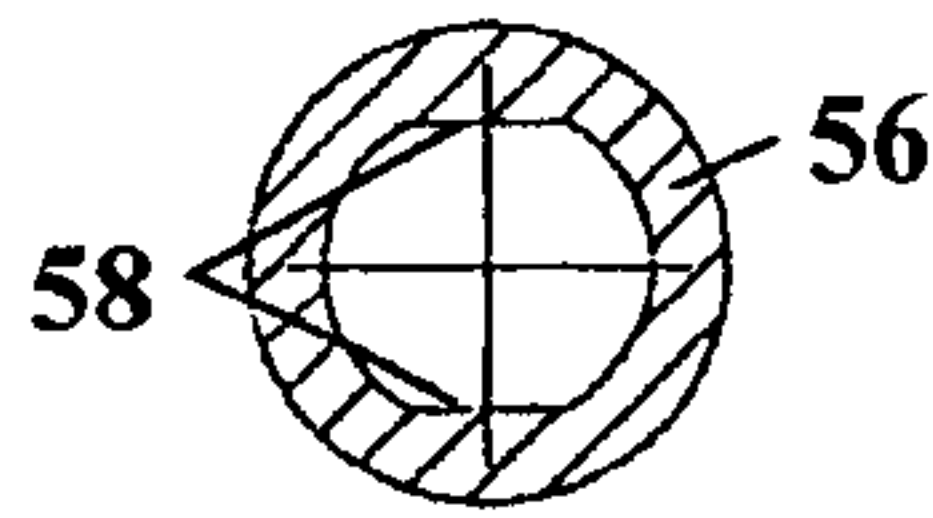

Fig. 20

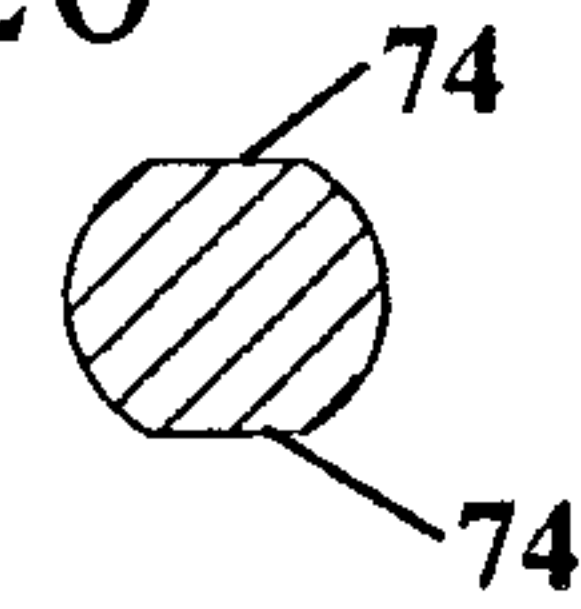

Fig. 21

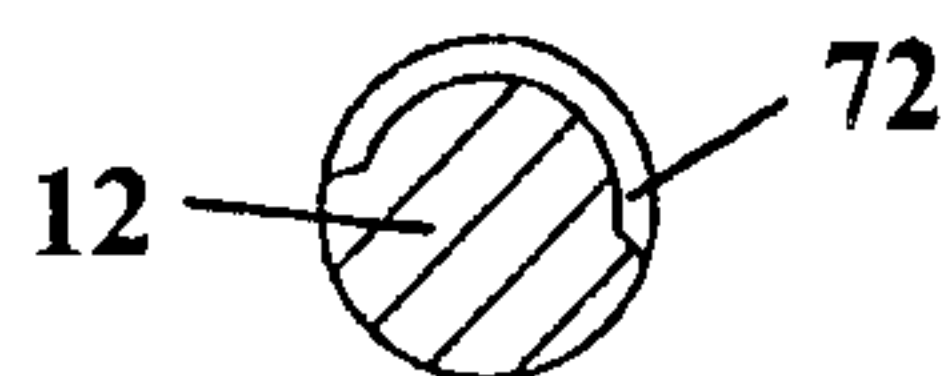

Fig. 19

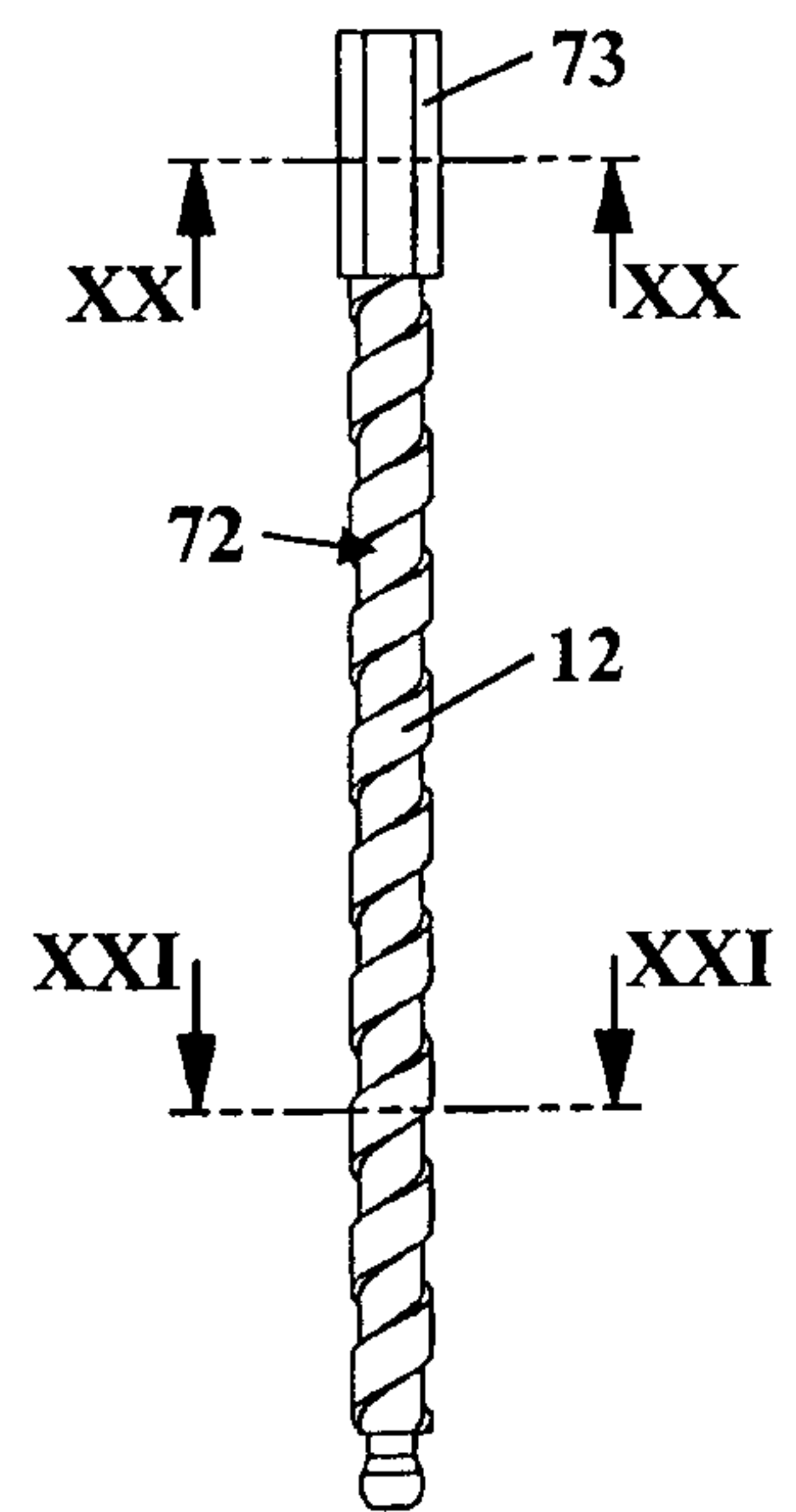

Fig. 22

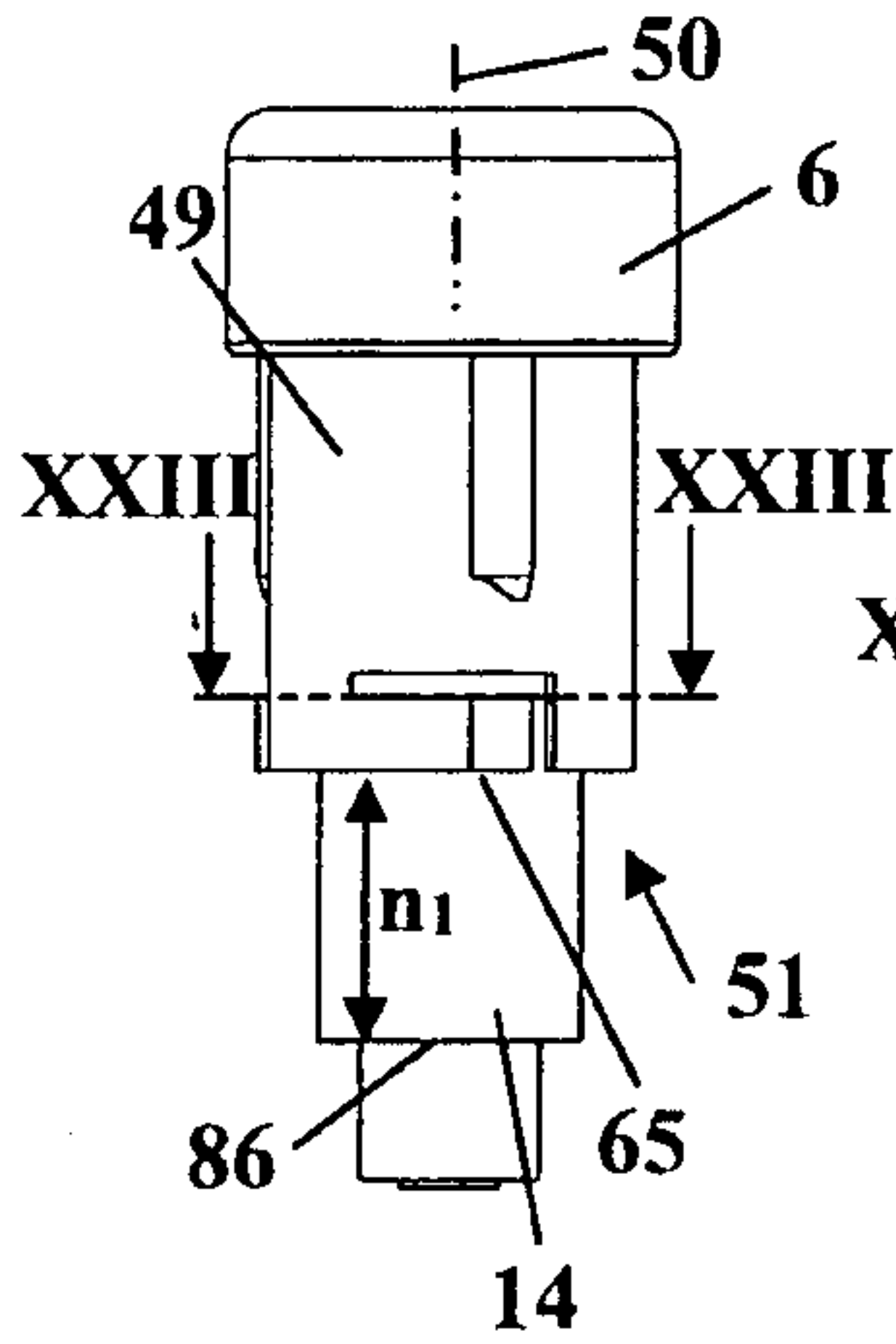

Fig. 24

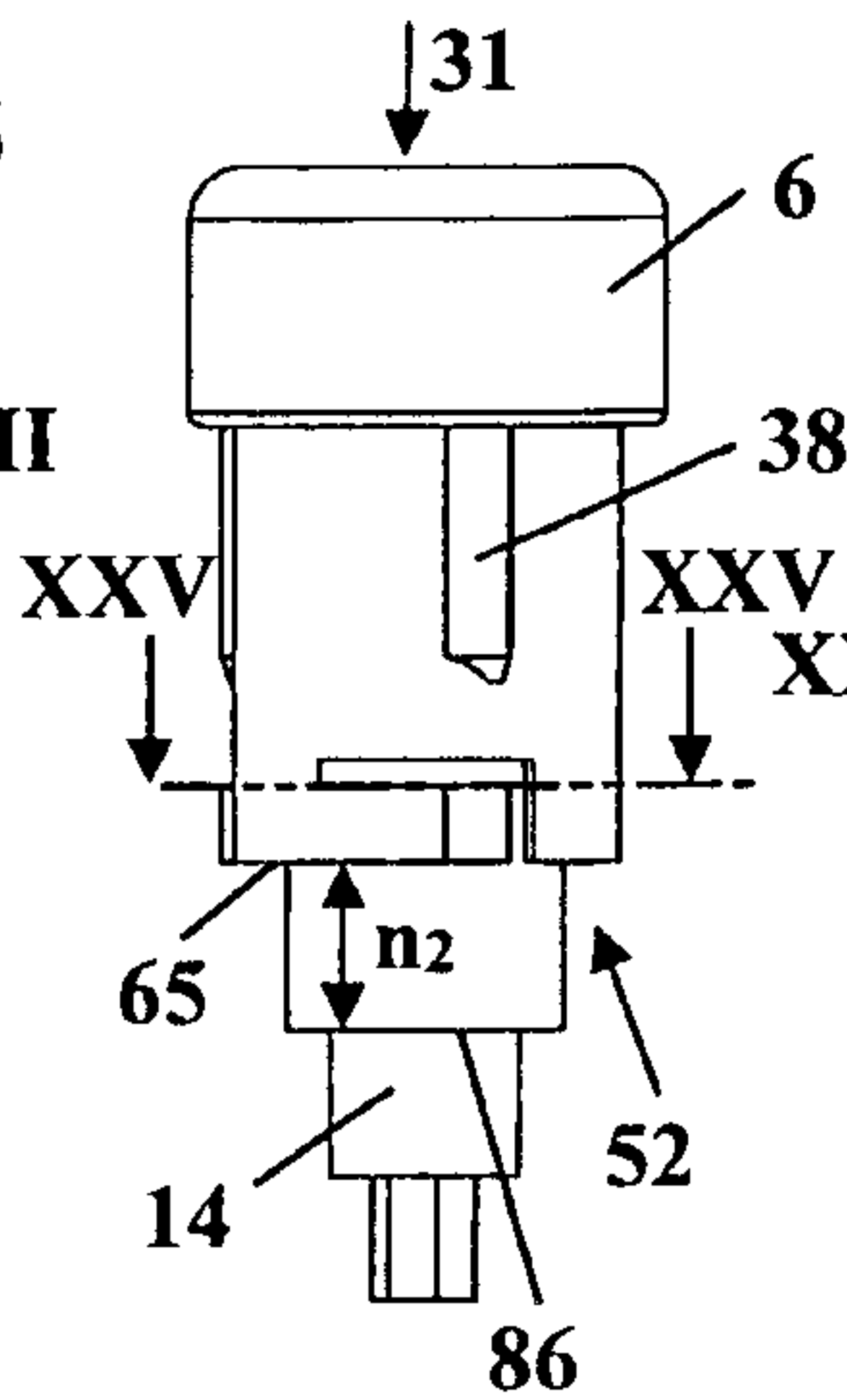

Fig. 26

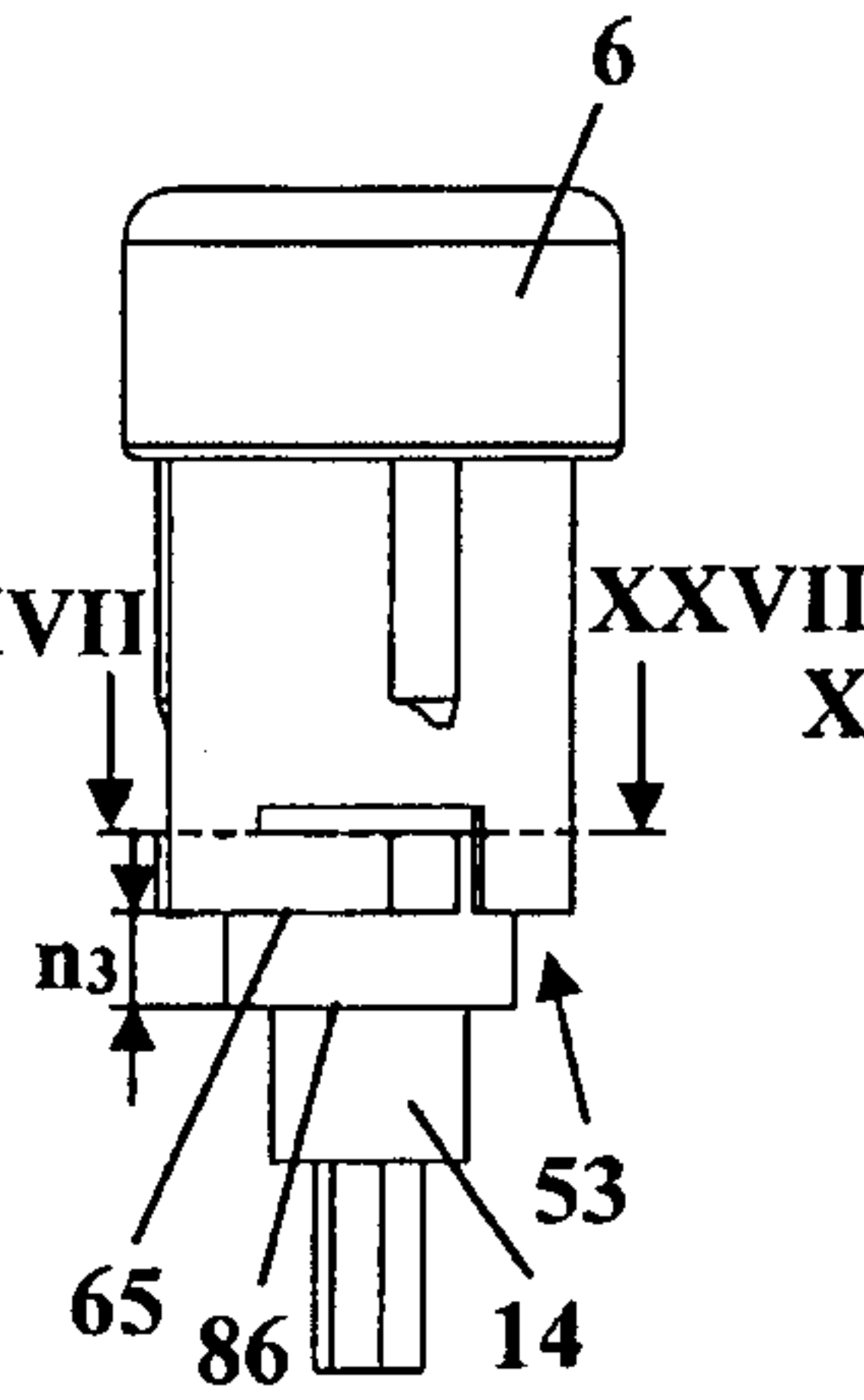

Fig. 28

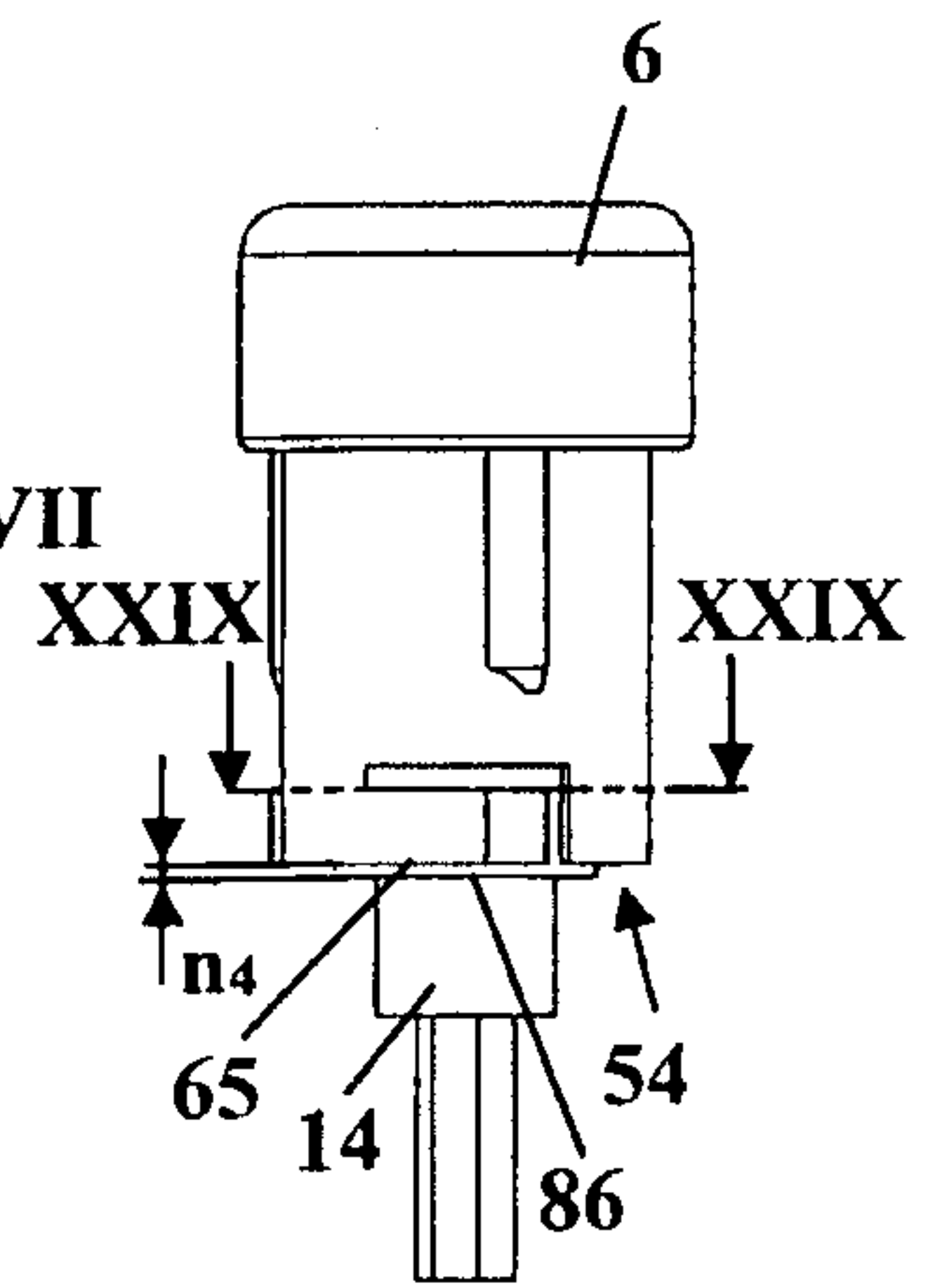

Fig. 23

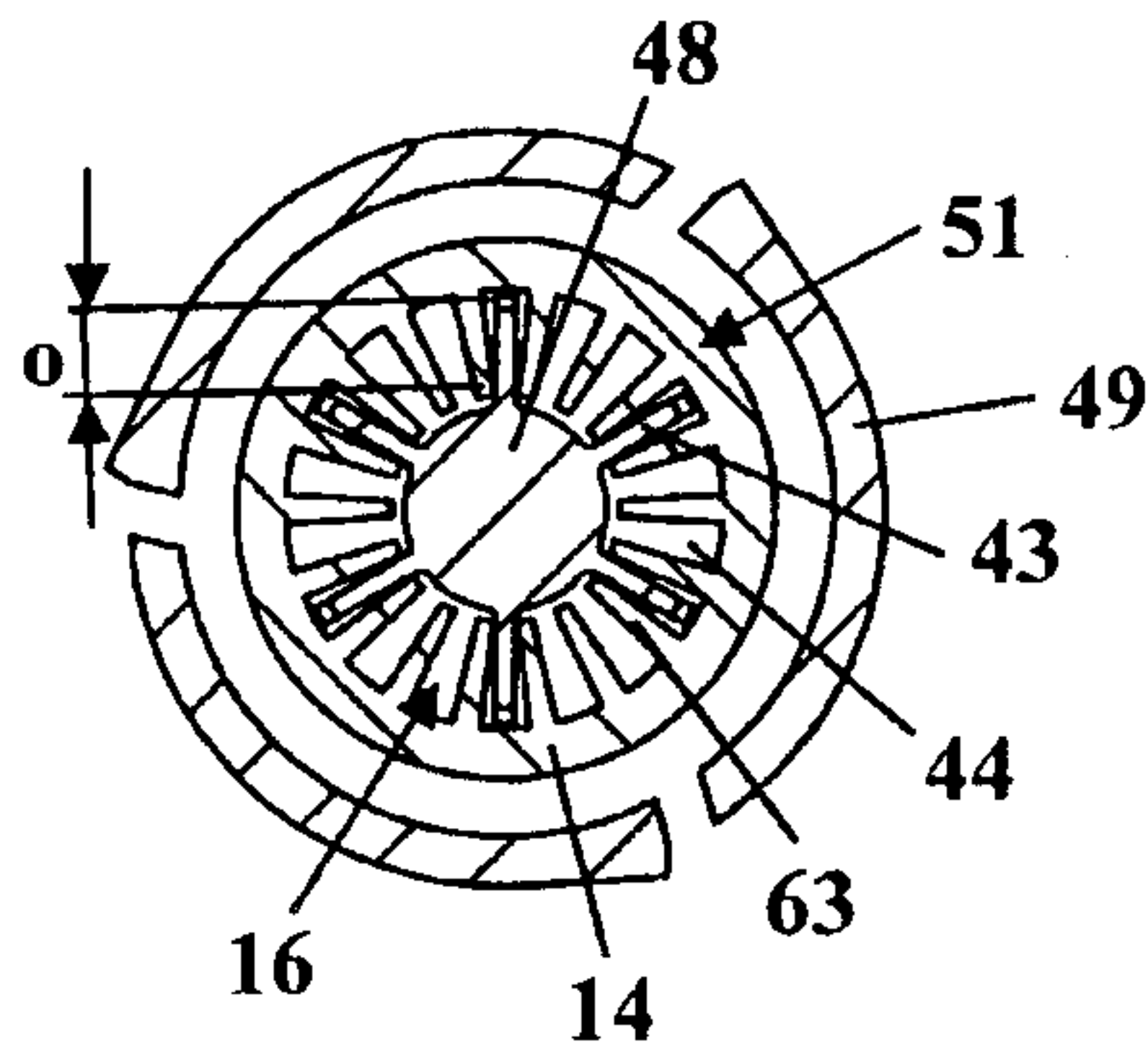

Fig. 27

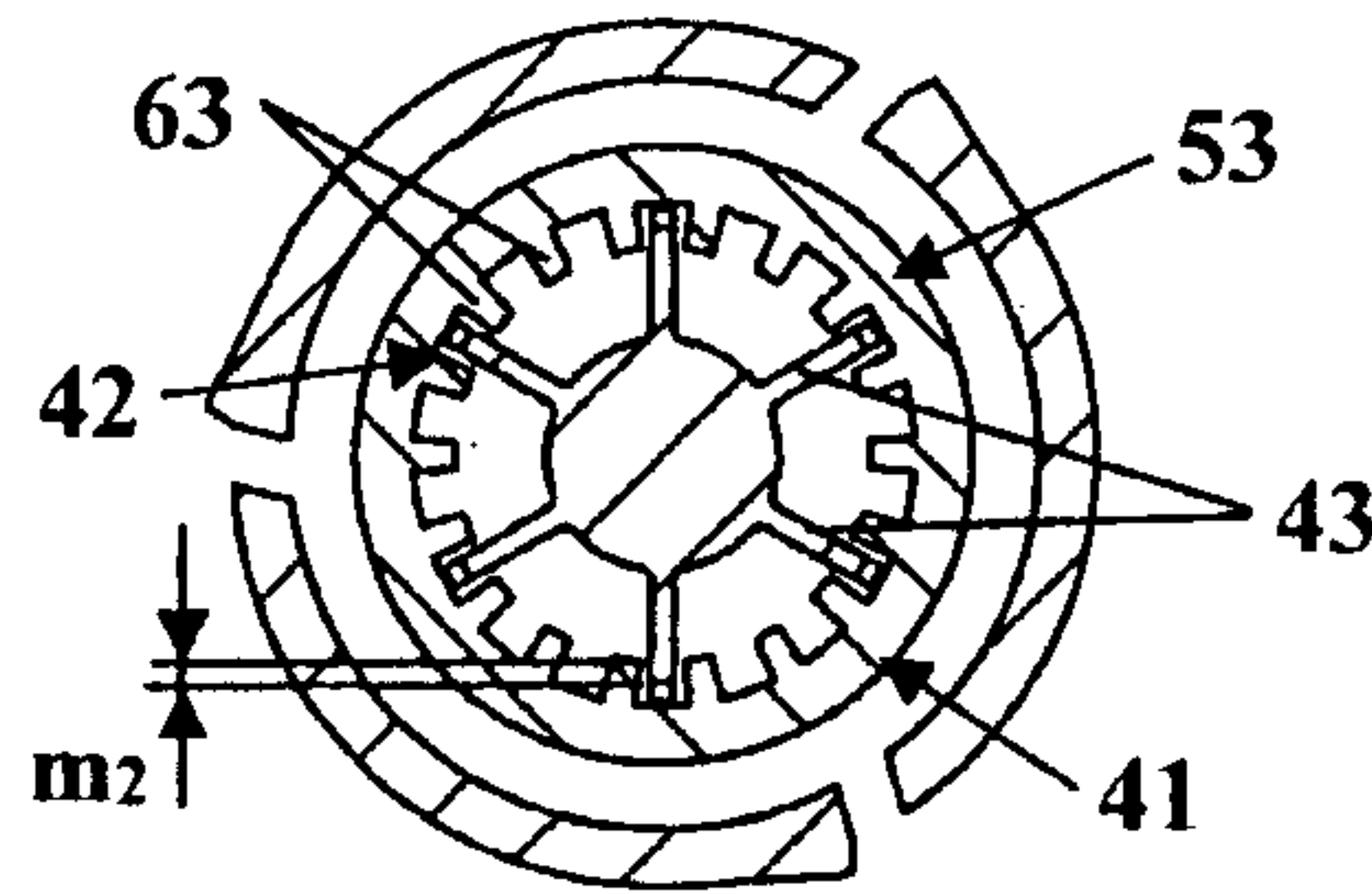

Fig. 25

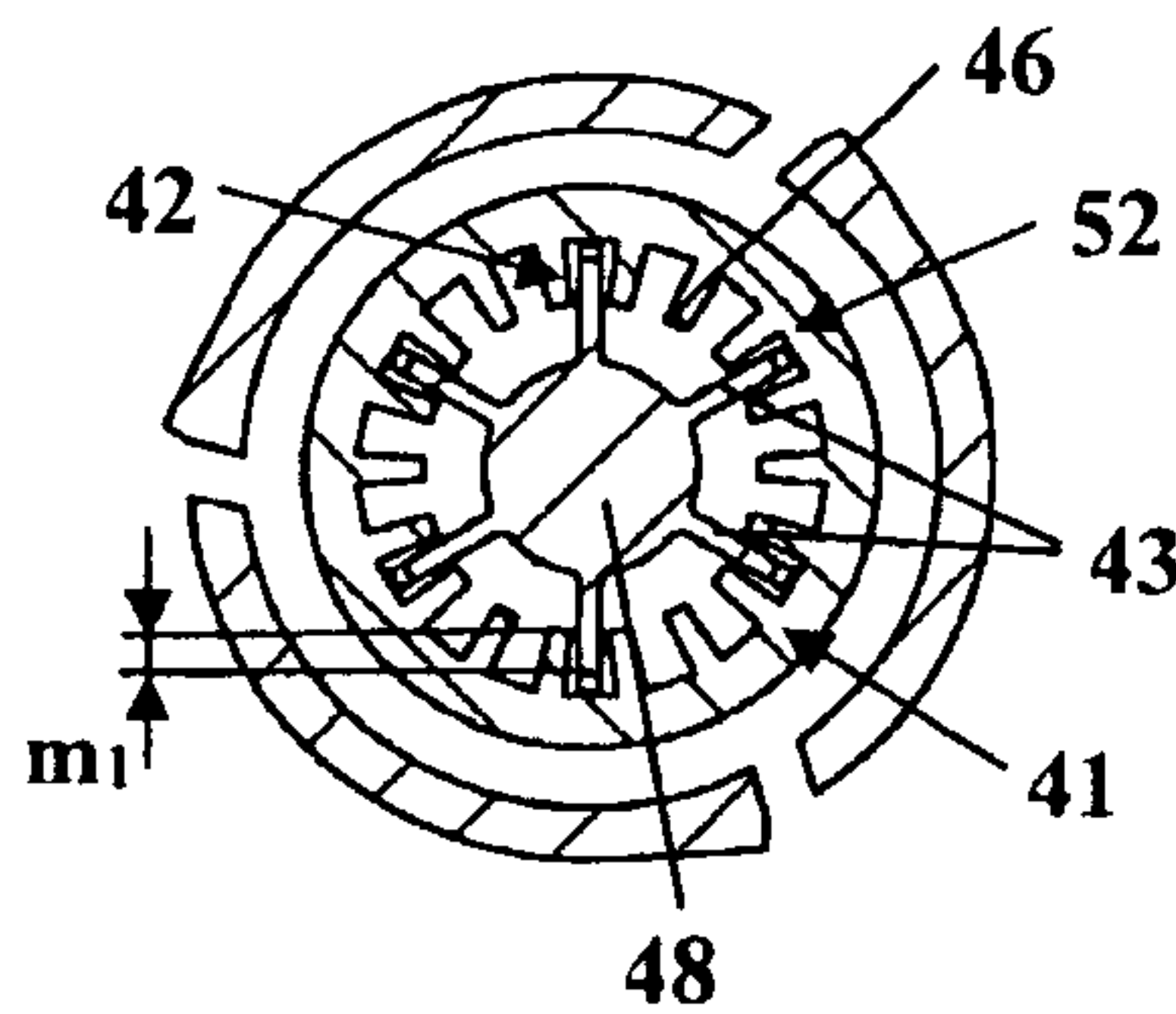

Fig. 29

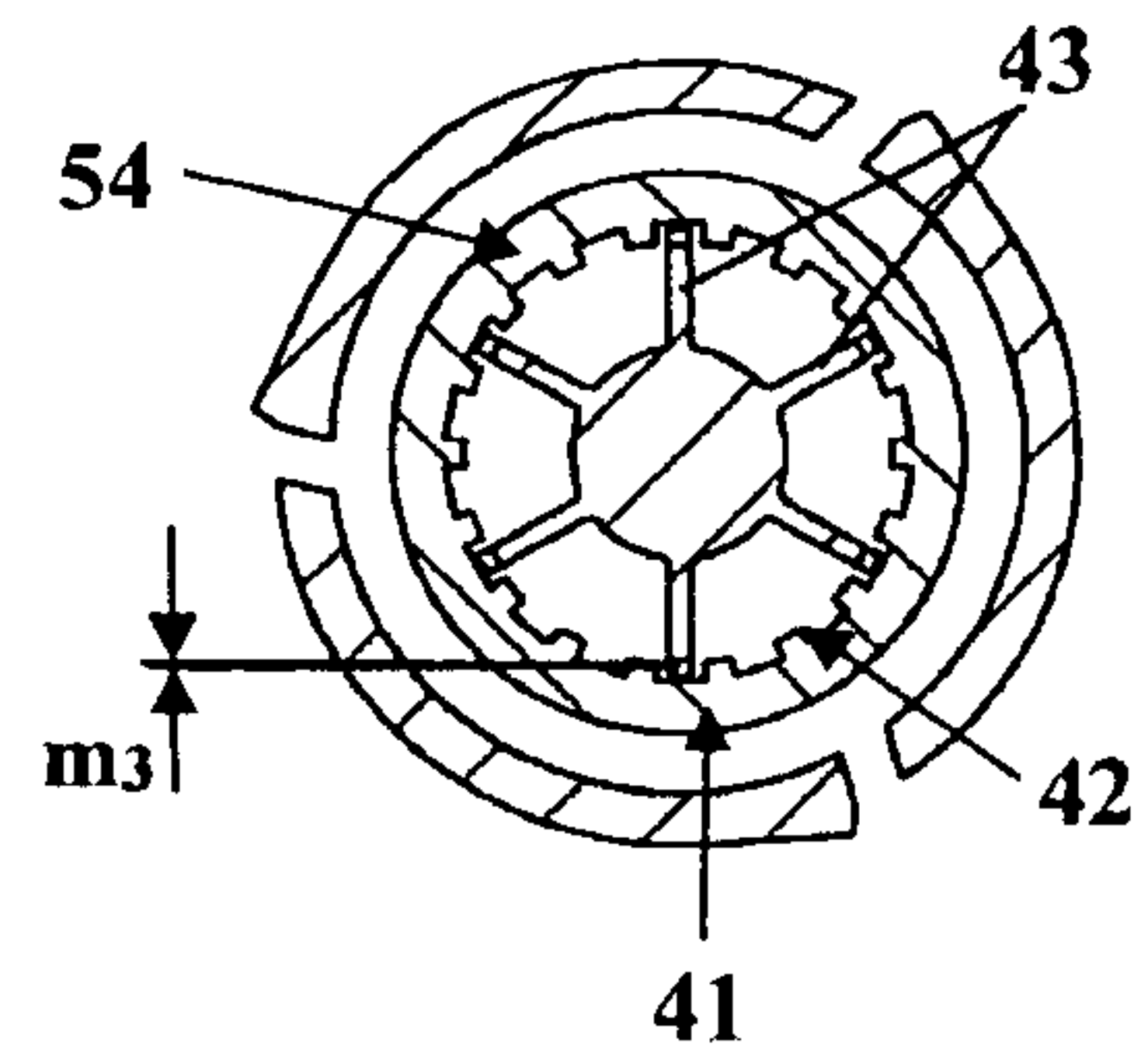

Fig. 30

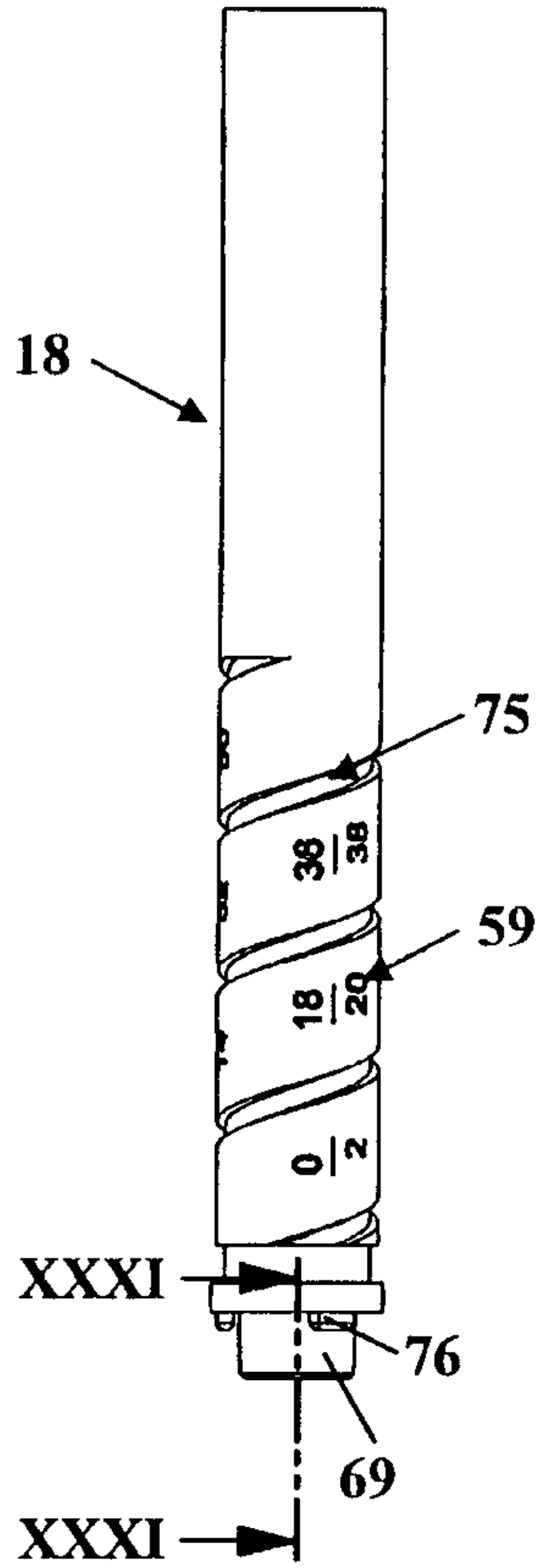

Fig. 31

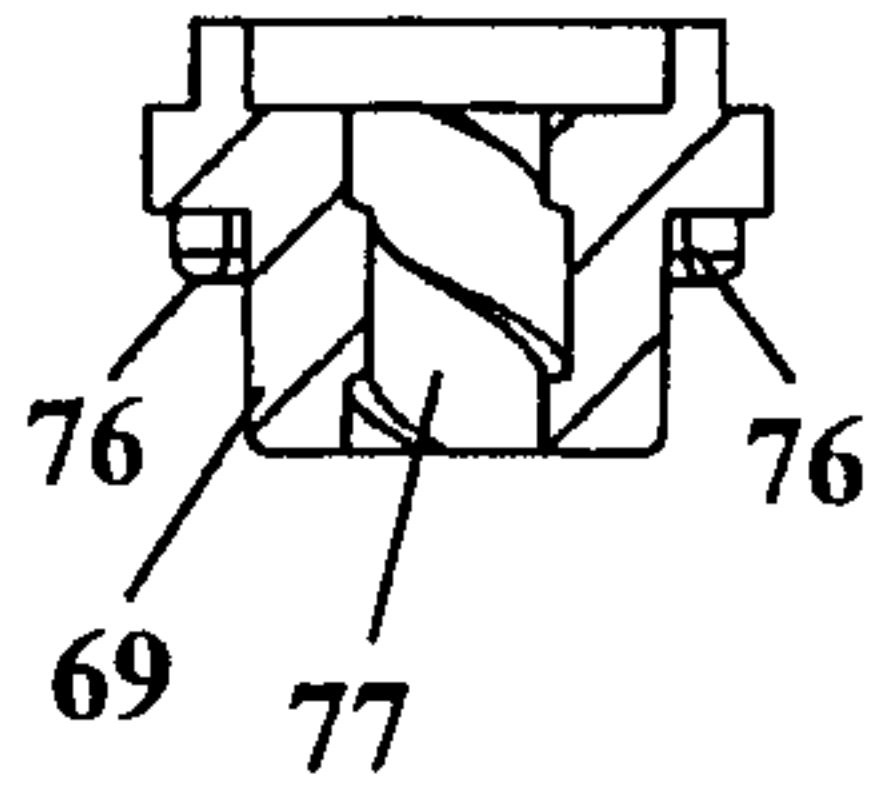

Fig. 32

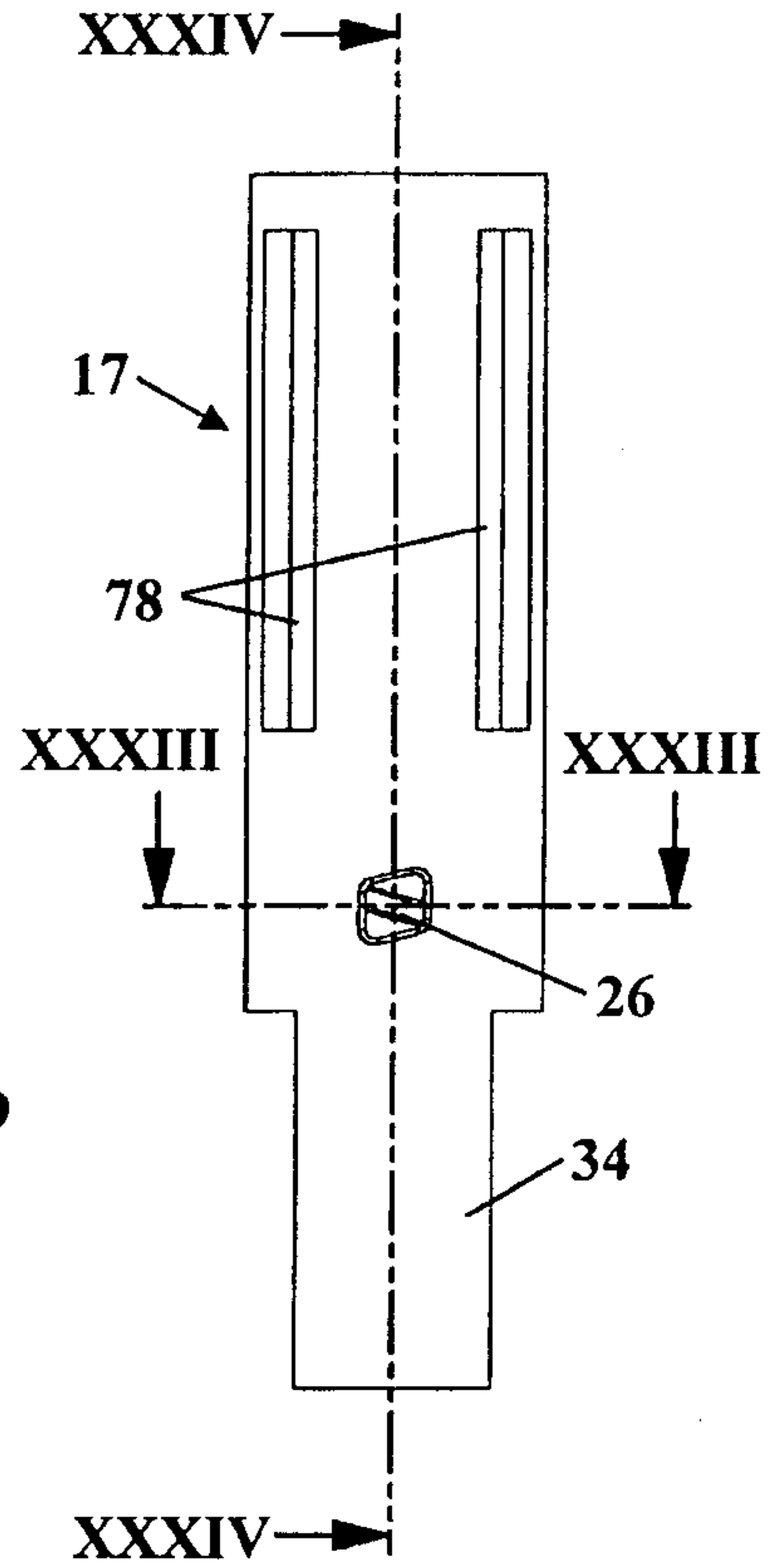

Fig. 33

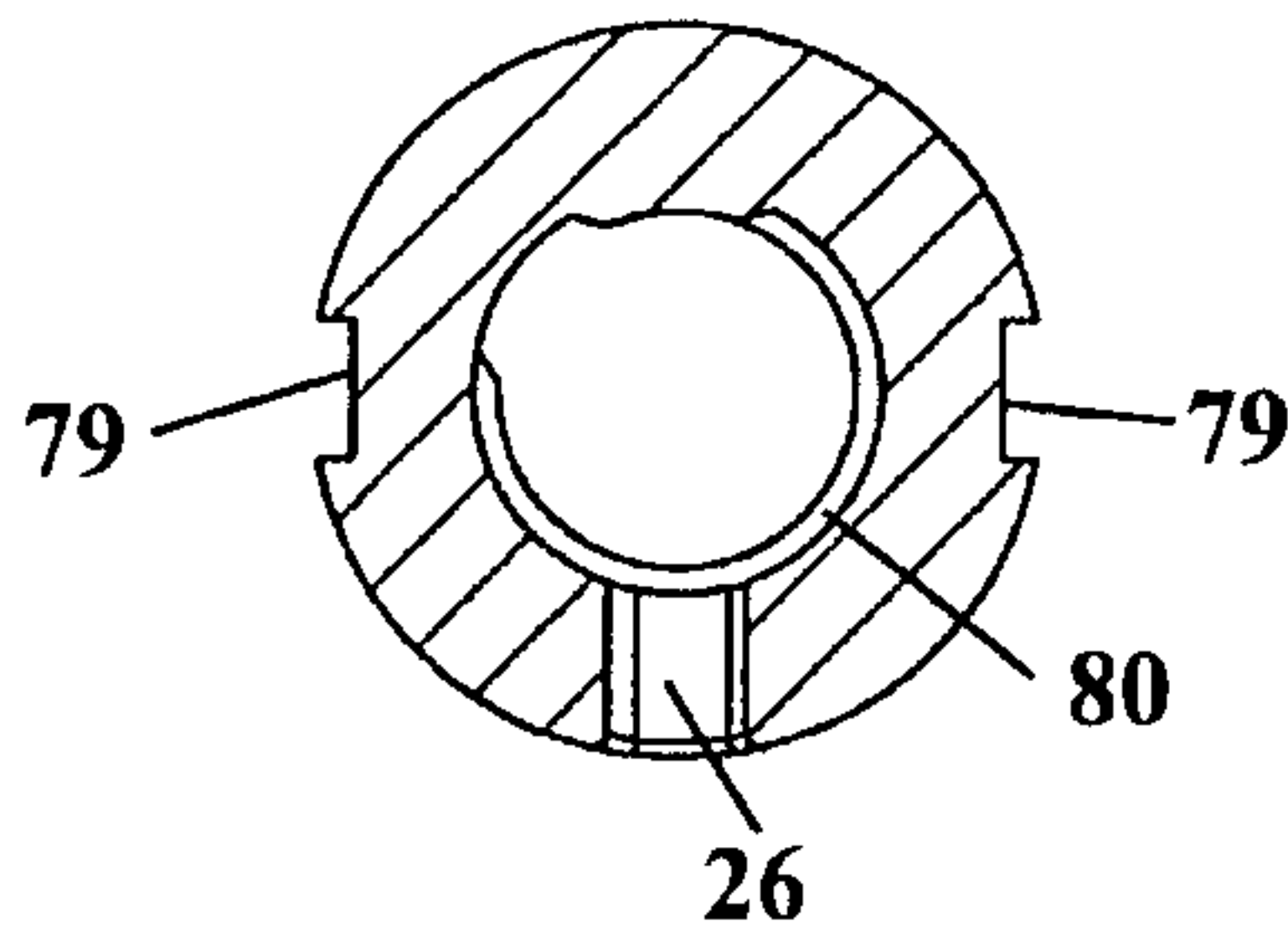

Fig. 34

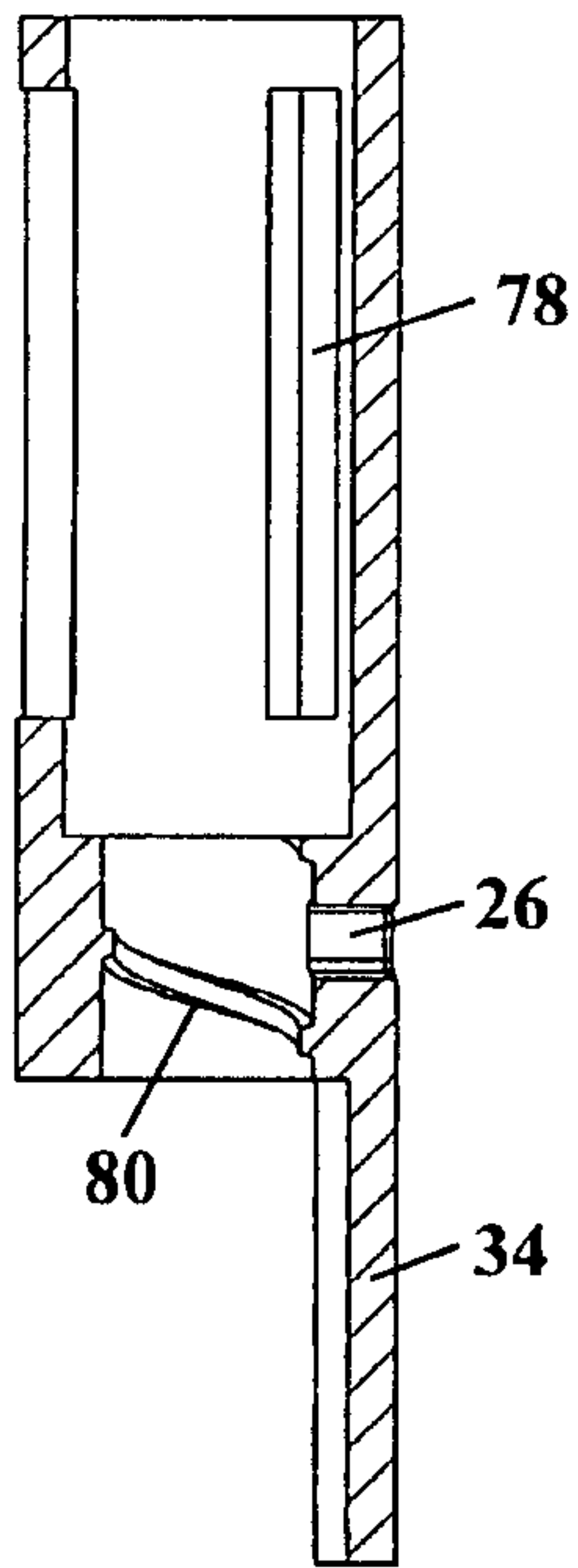

Fig. 35

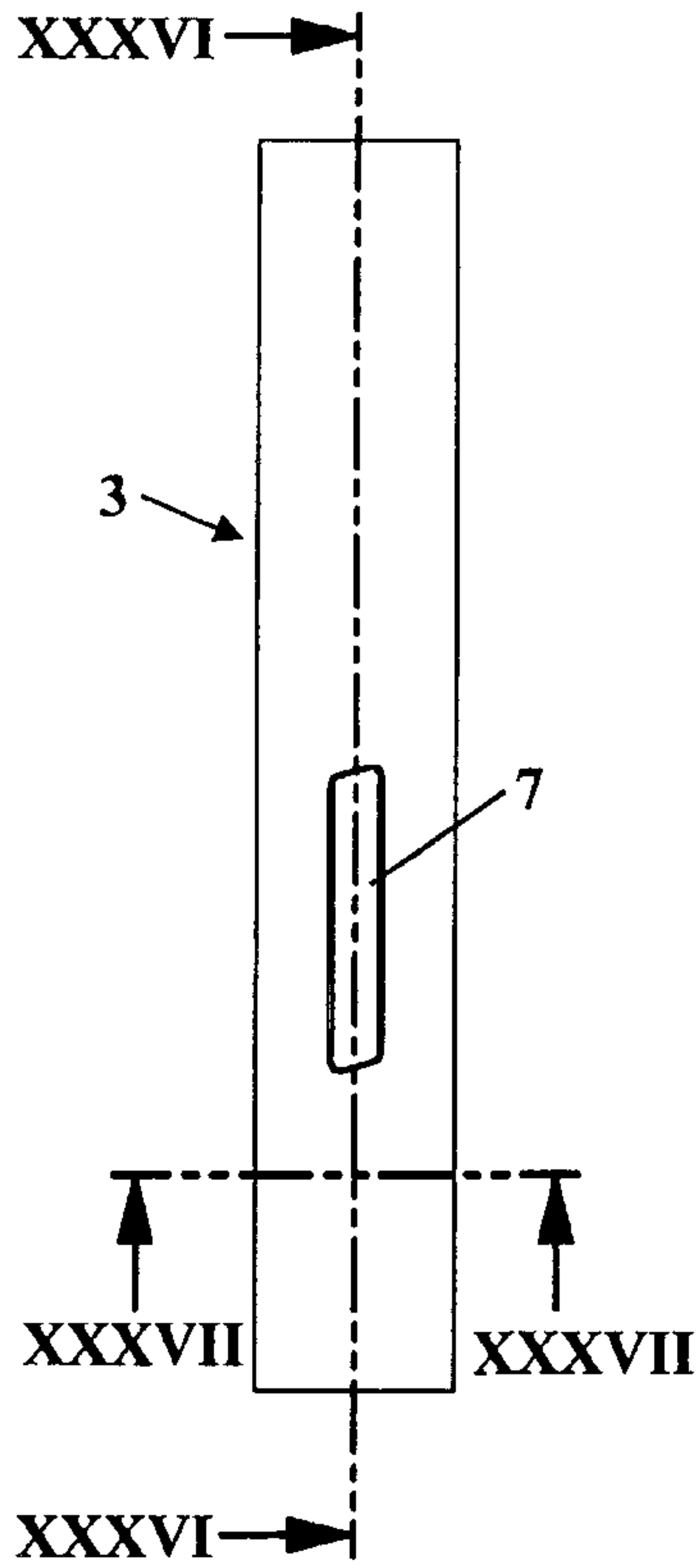

Fig. 36

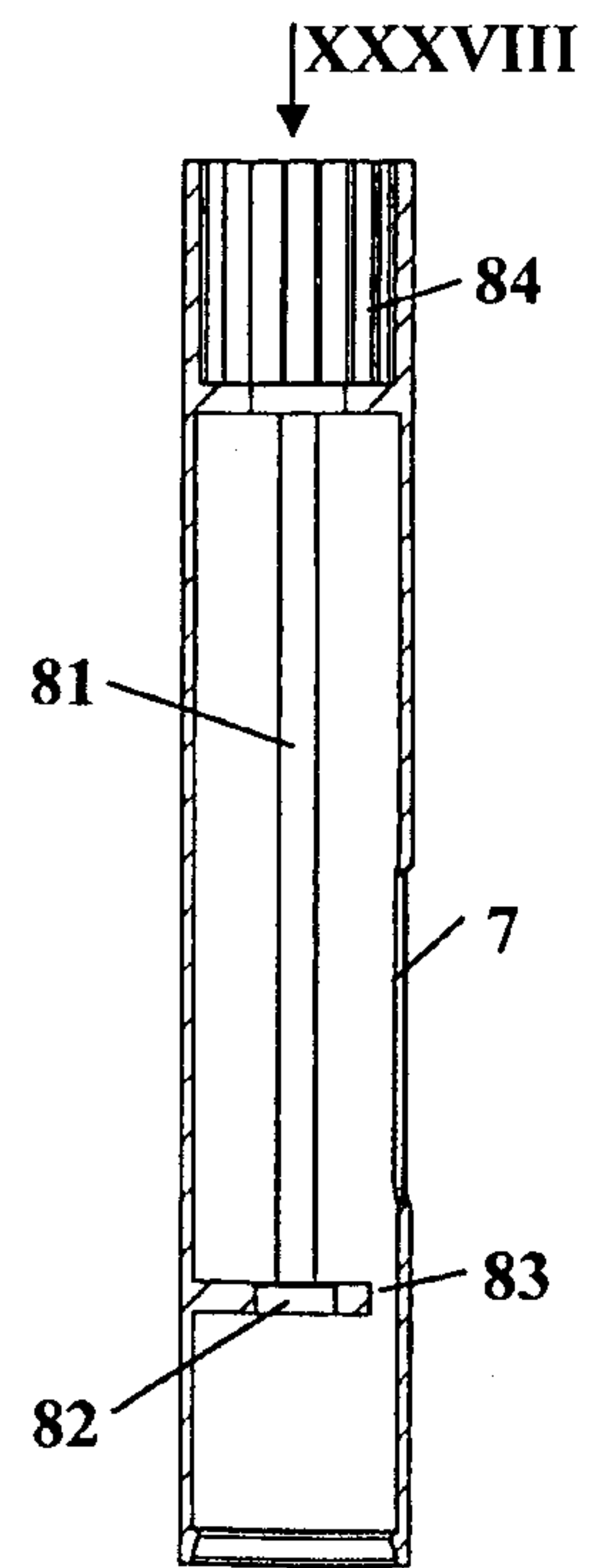

Fig. 37

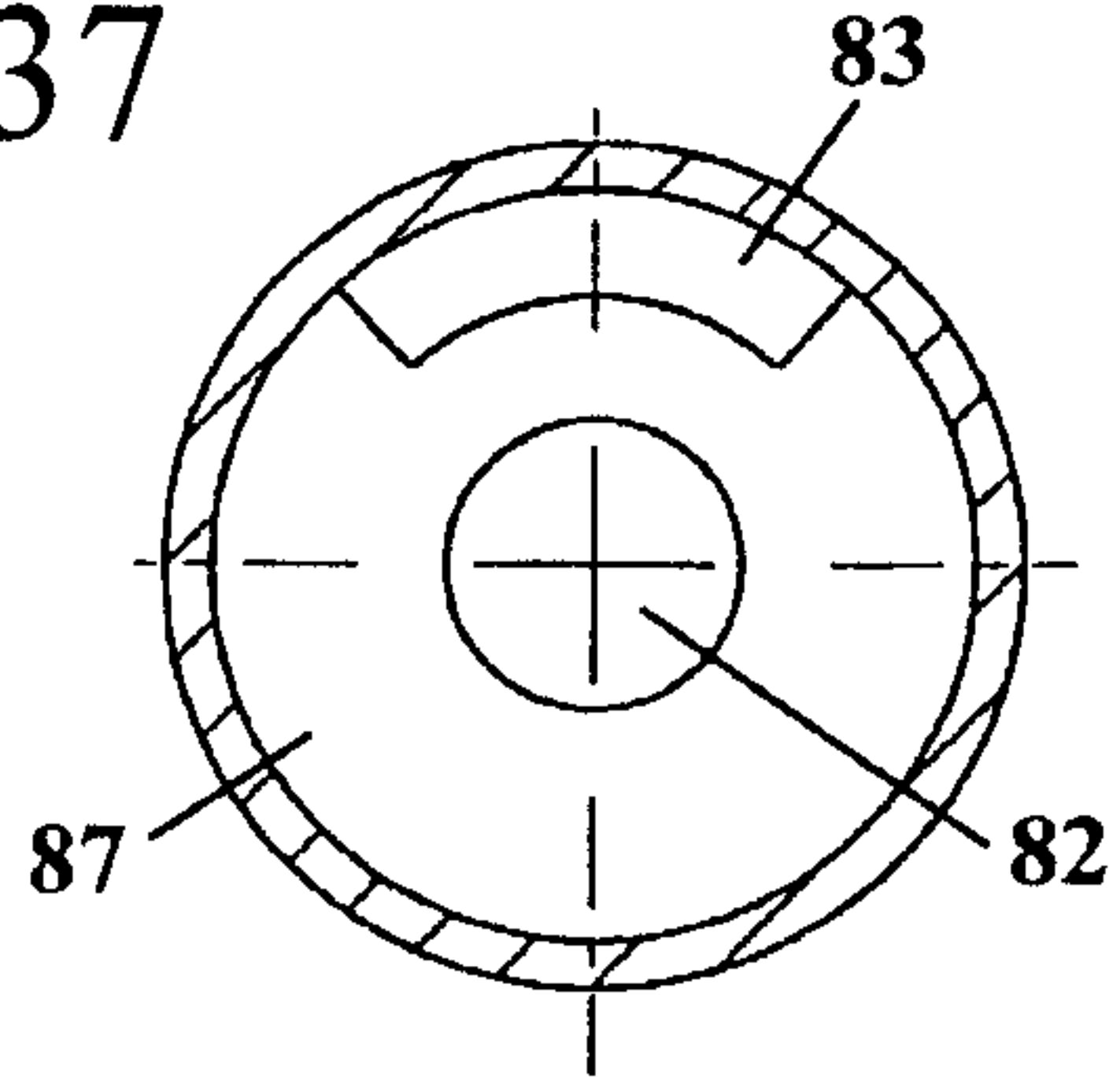

Fig. 38

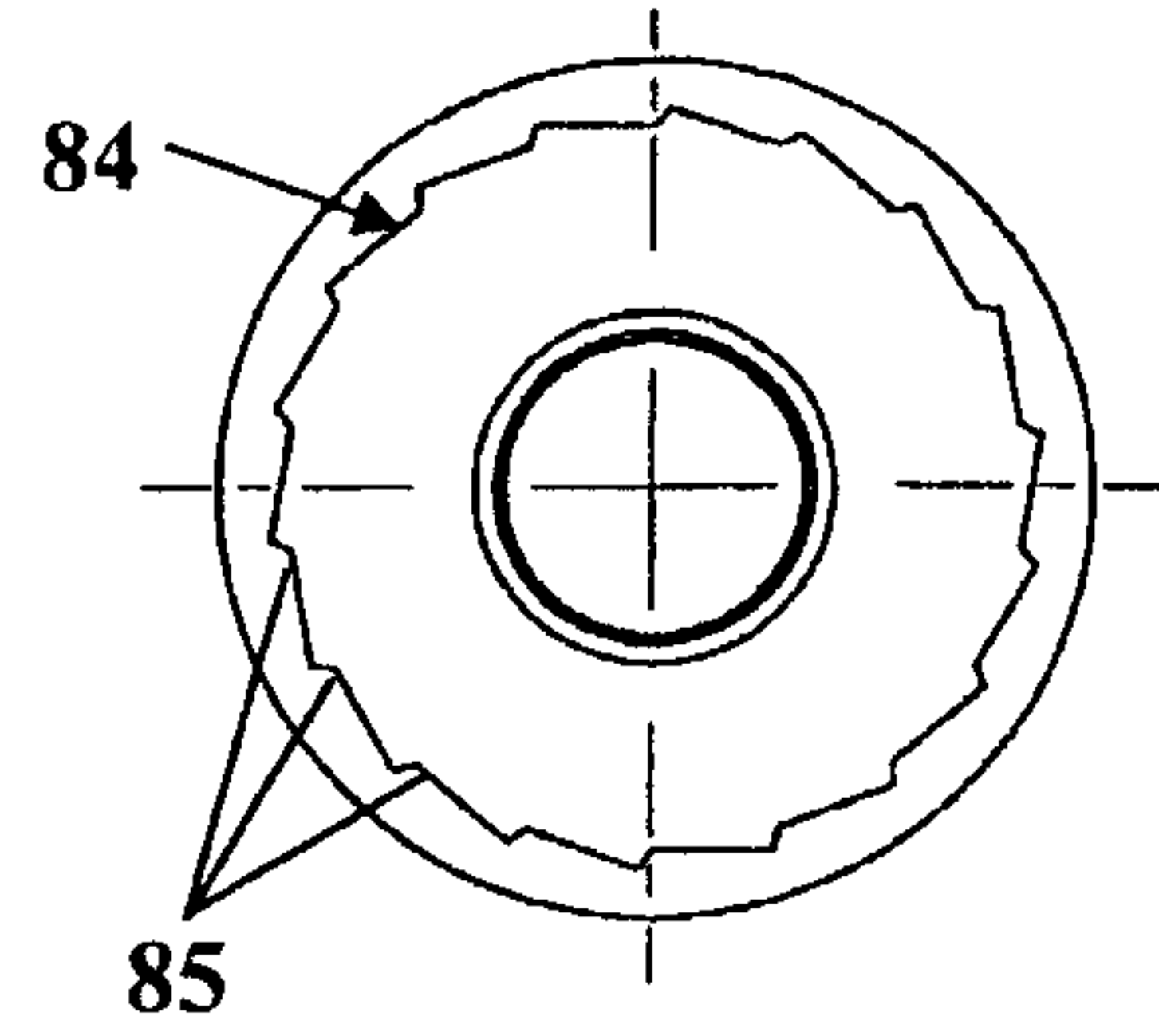

Fig. 39

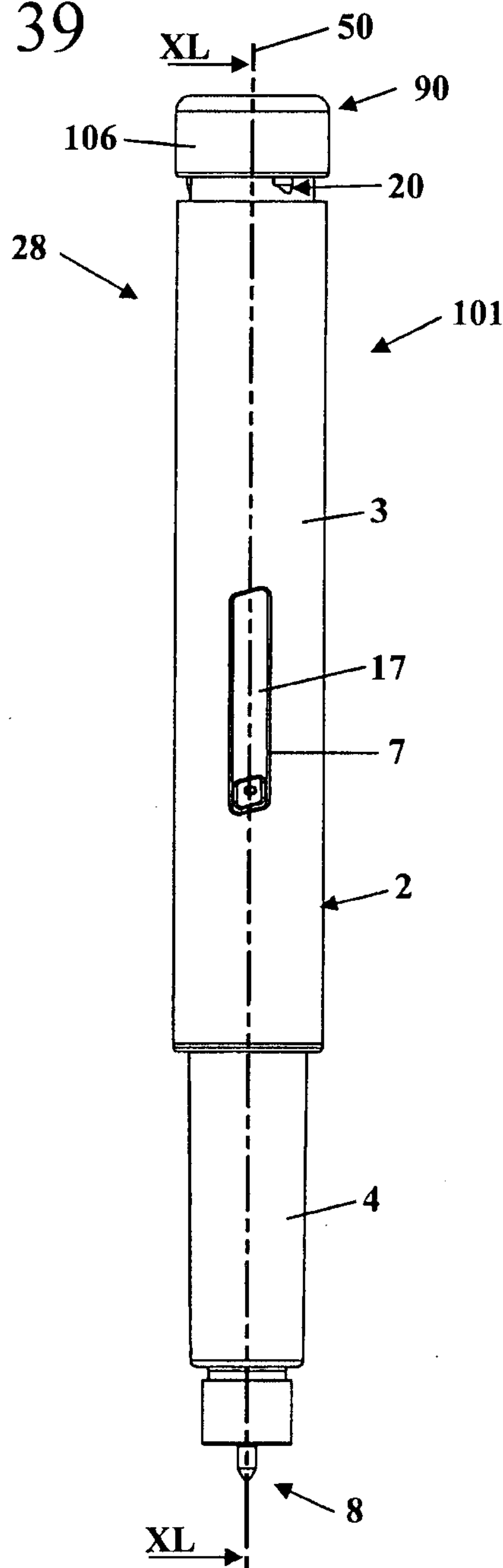

Fig. 40

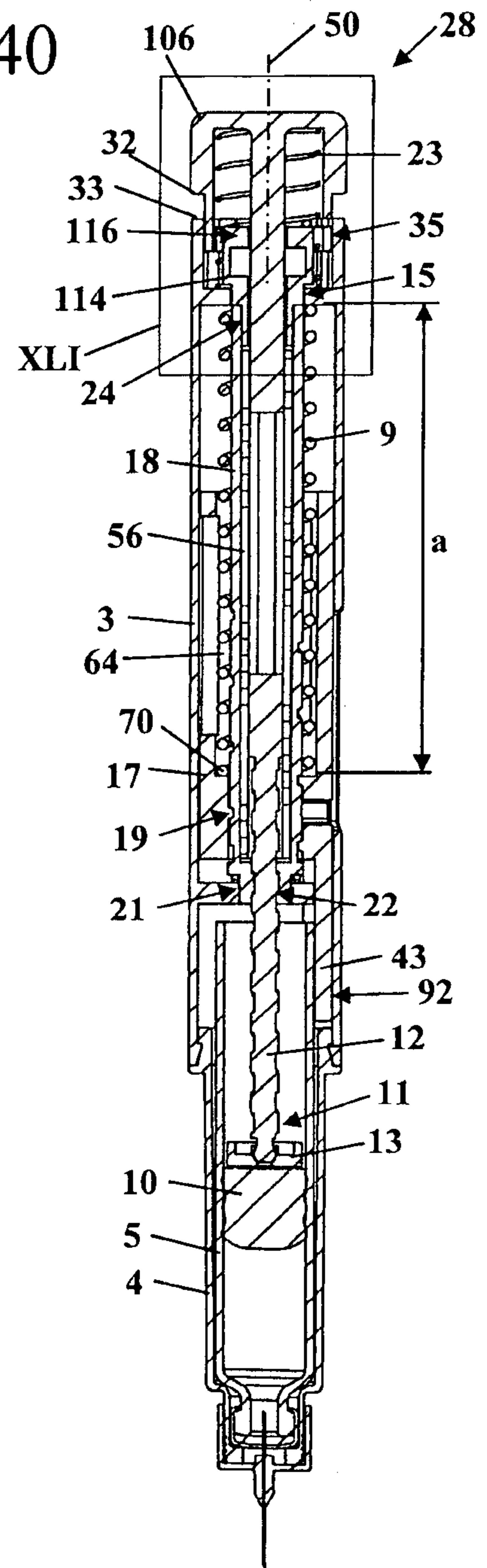

Fig. 41

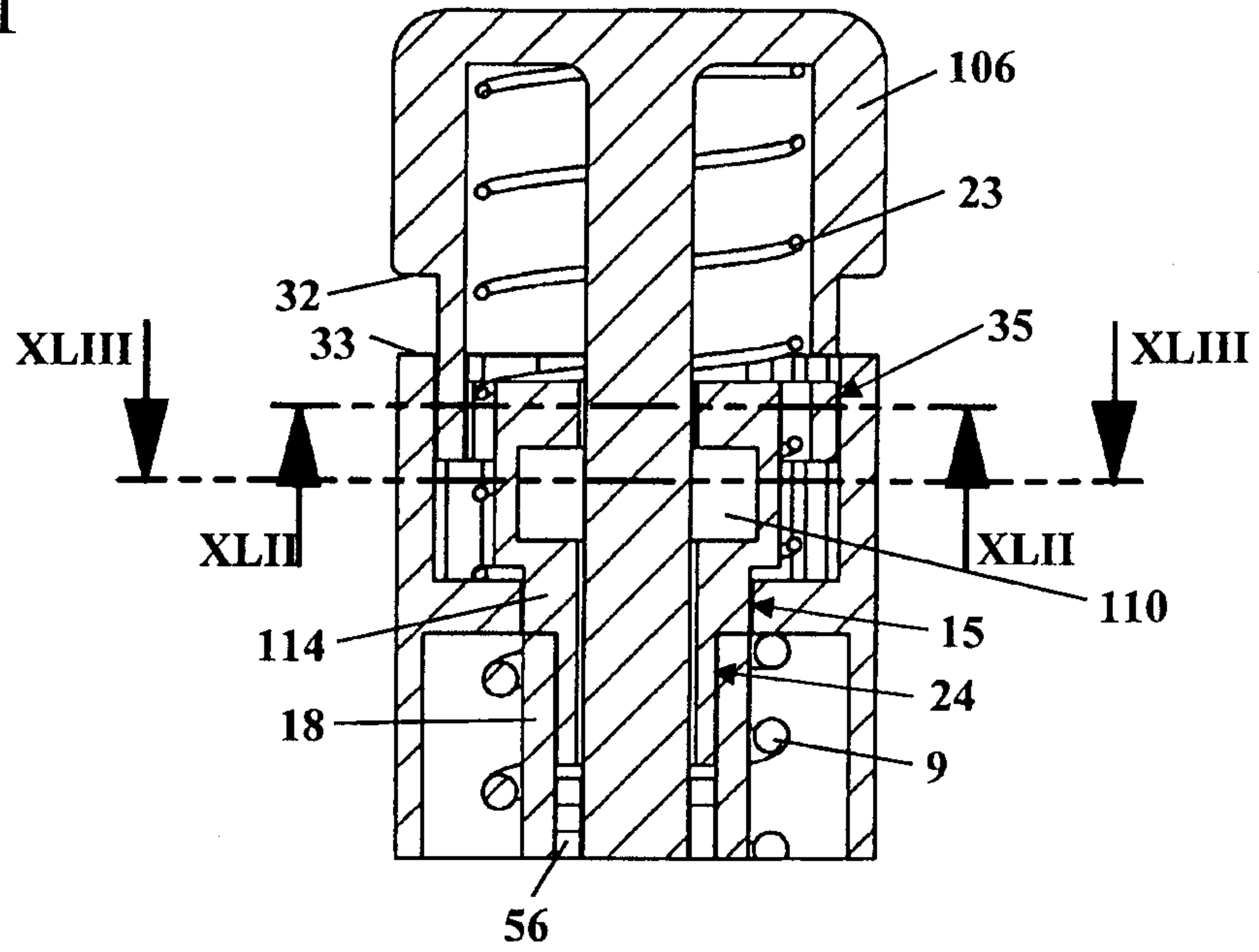

Fig. 42

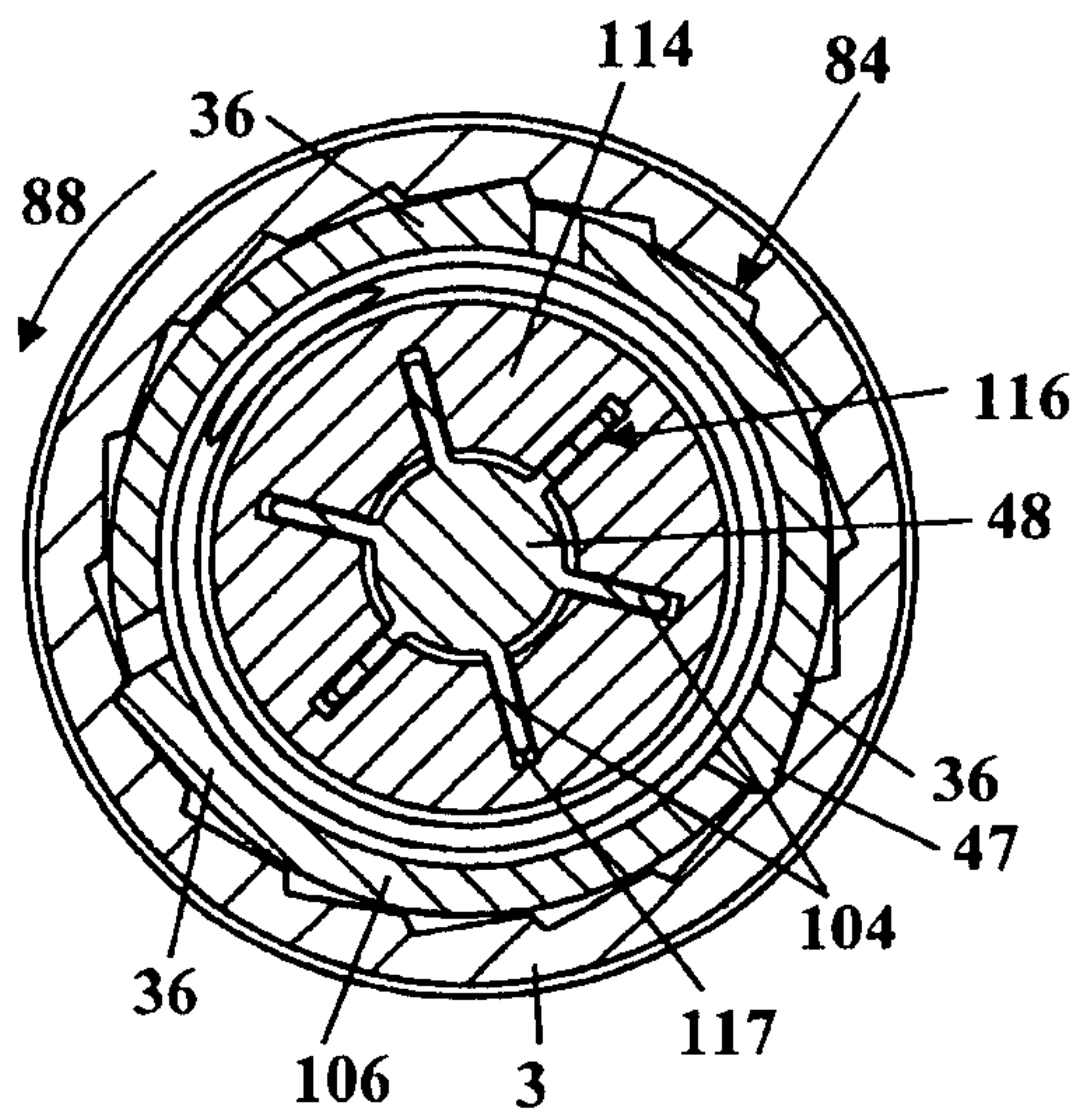

Fig. 43

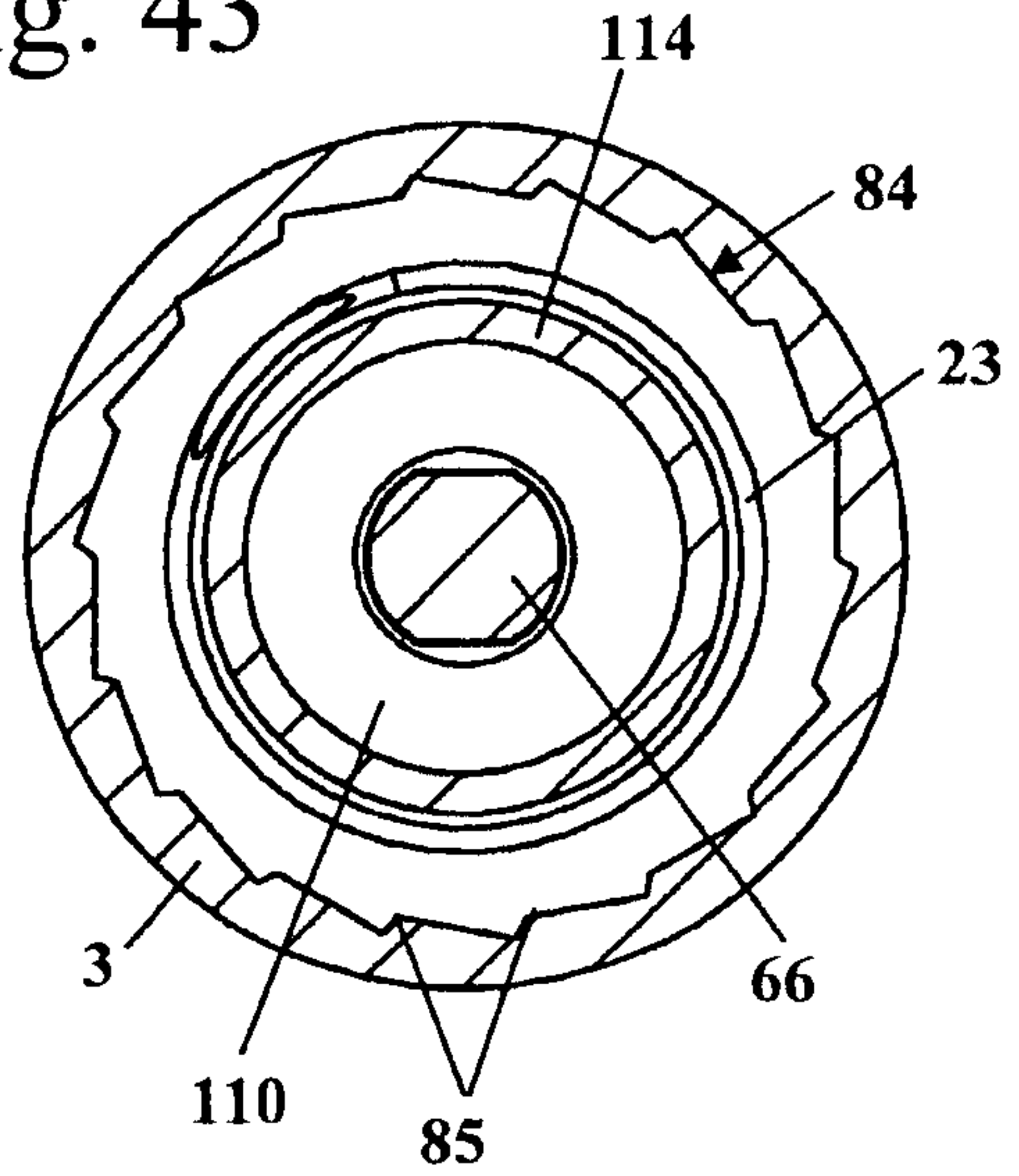

Fig. 44

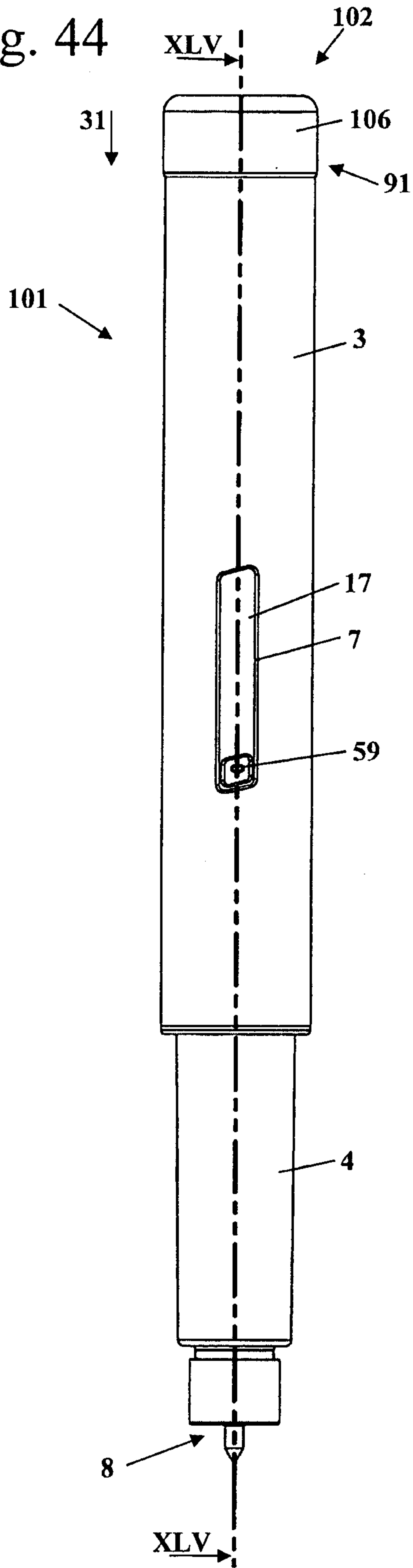

Fig. 45

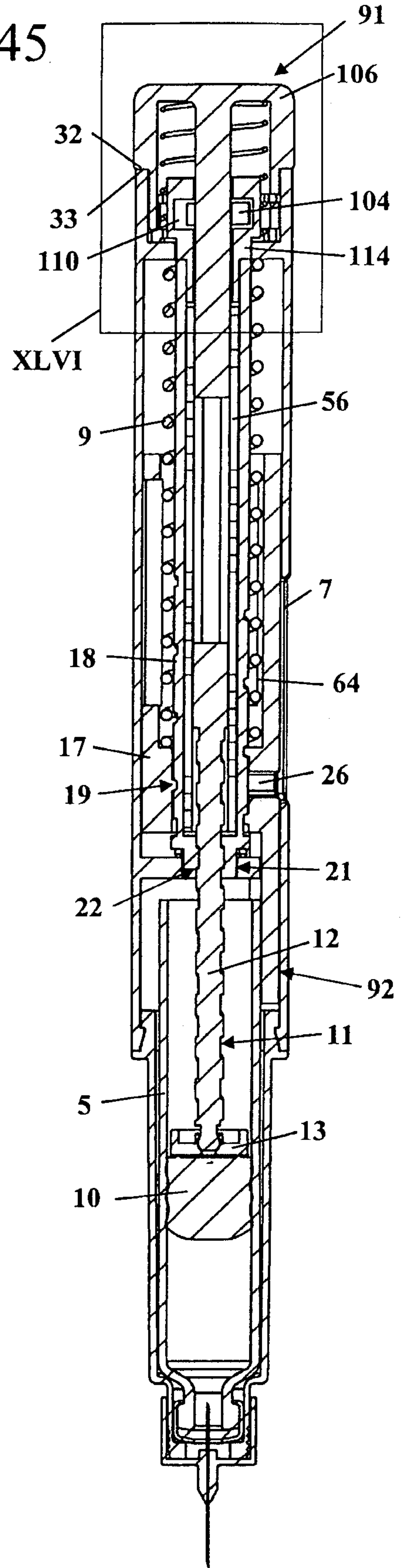

Fig. 49

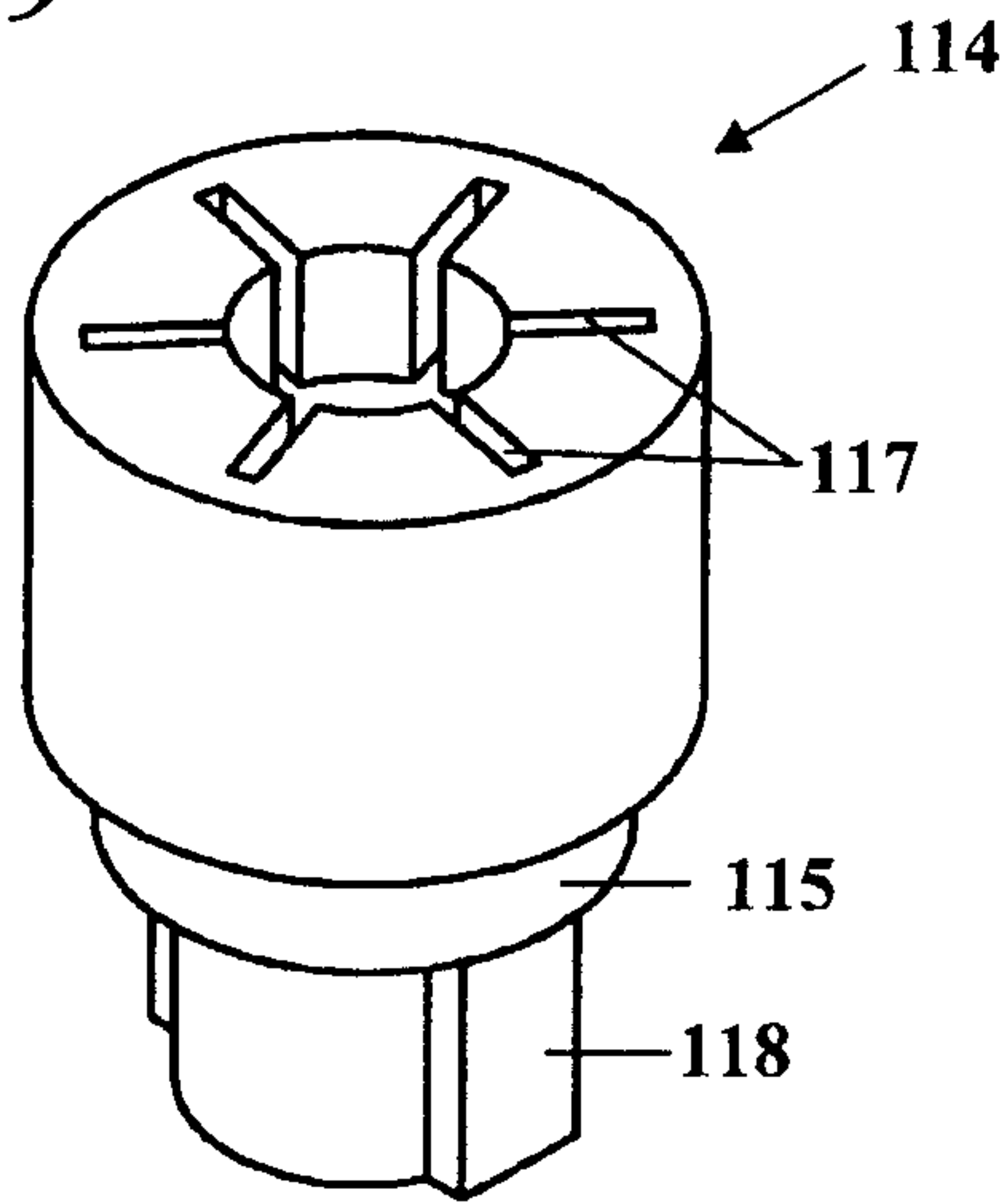

Fig. 50

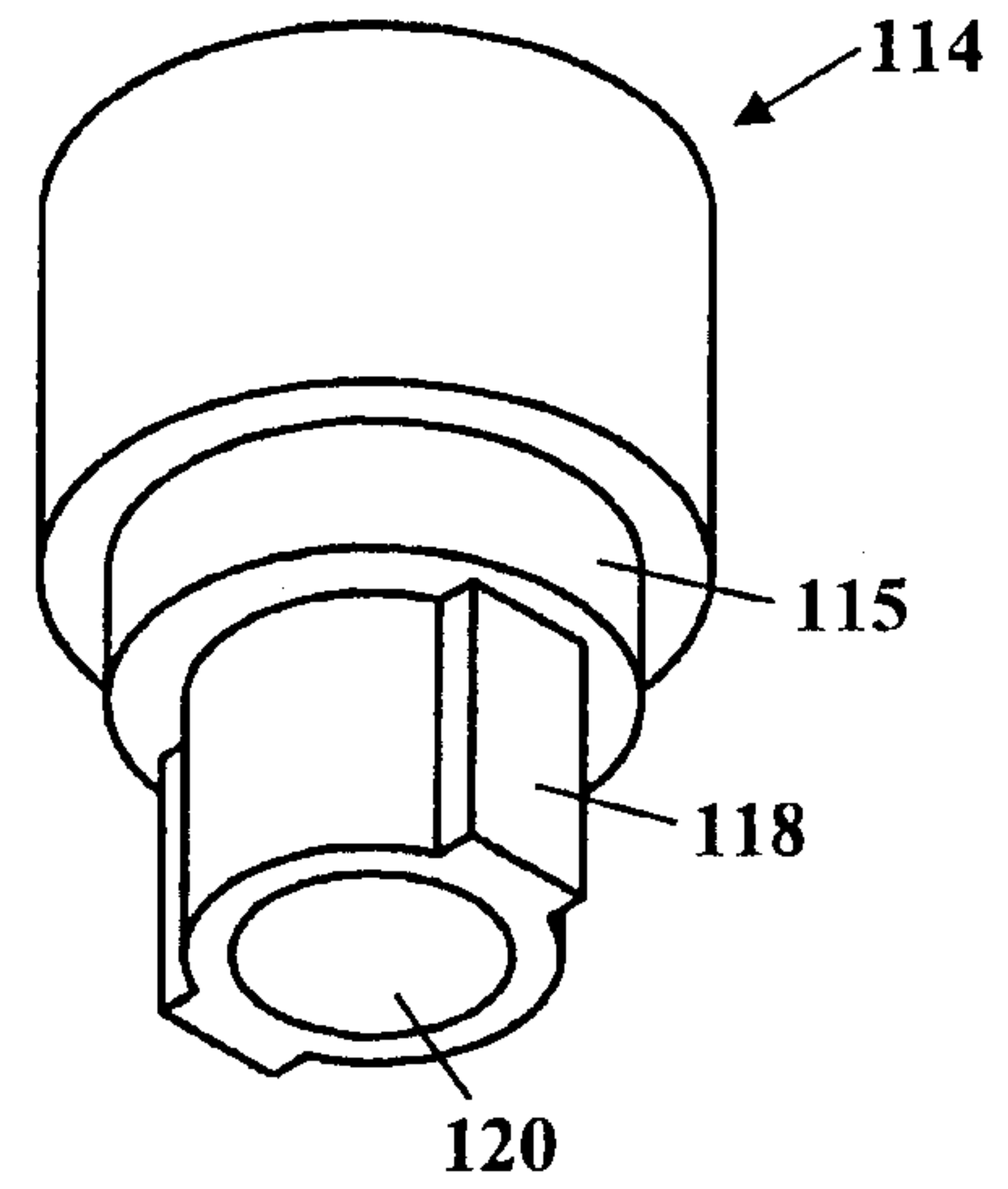

Fig. 51

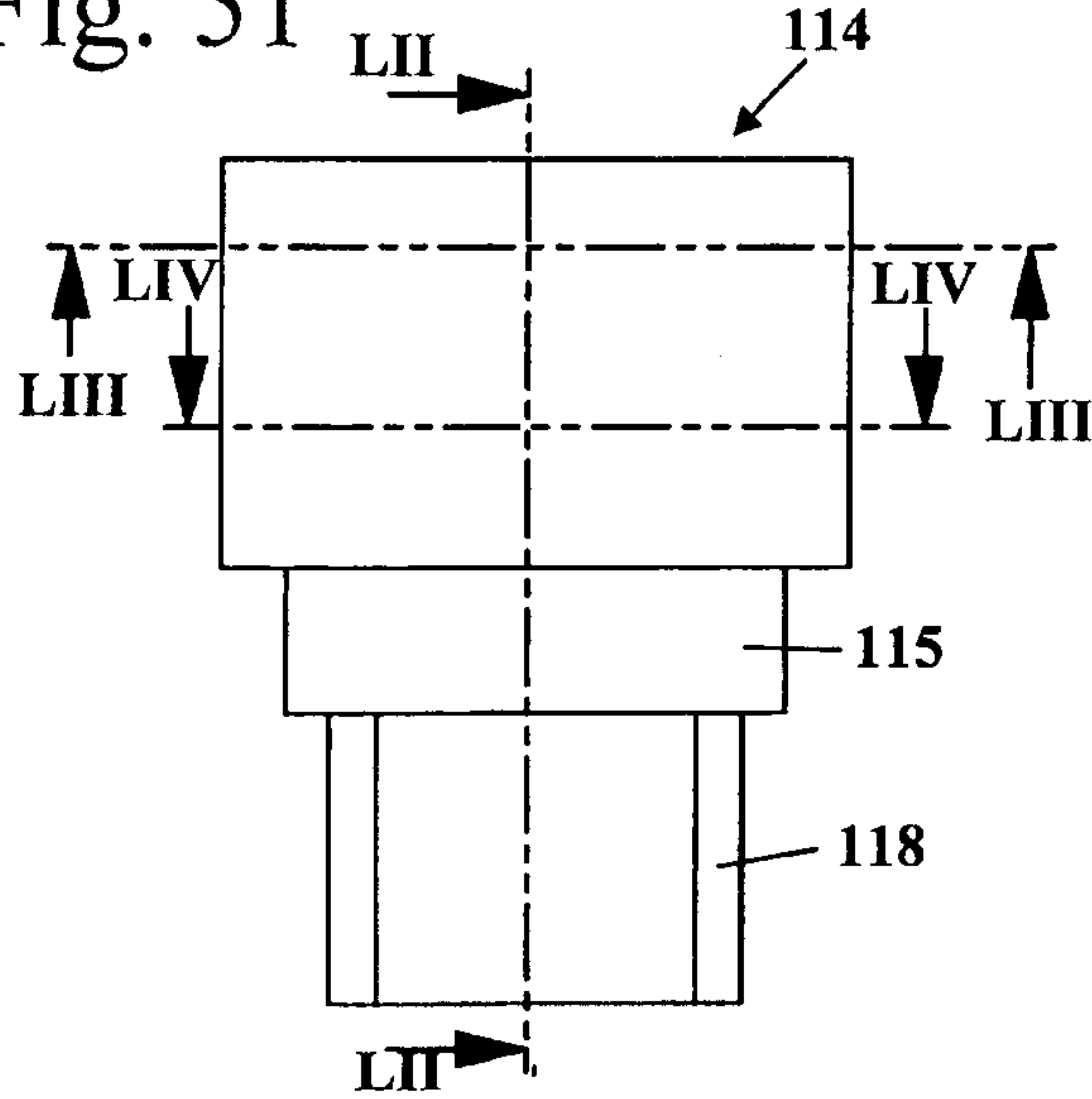

Fig. 52

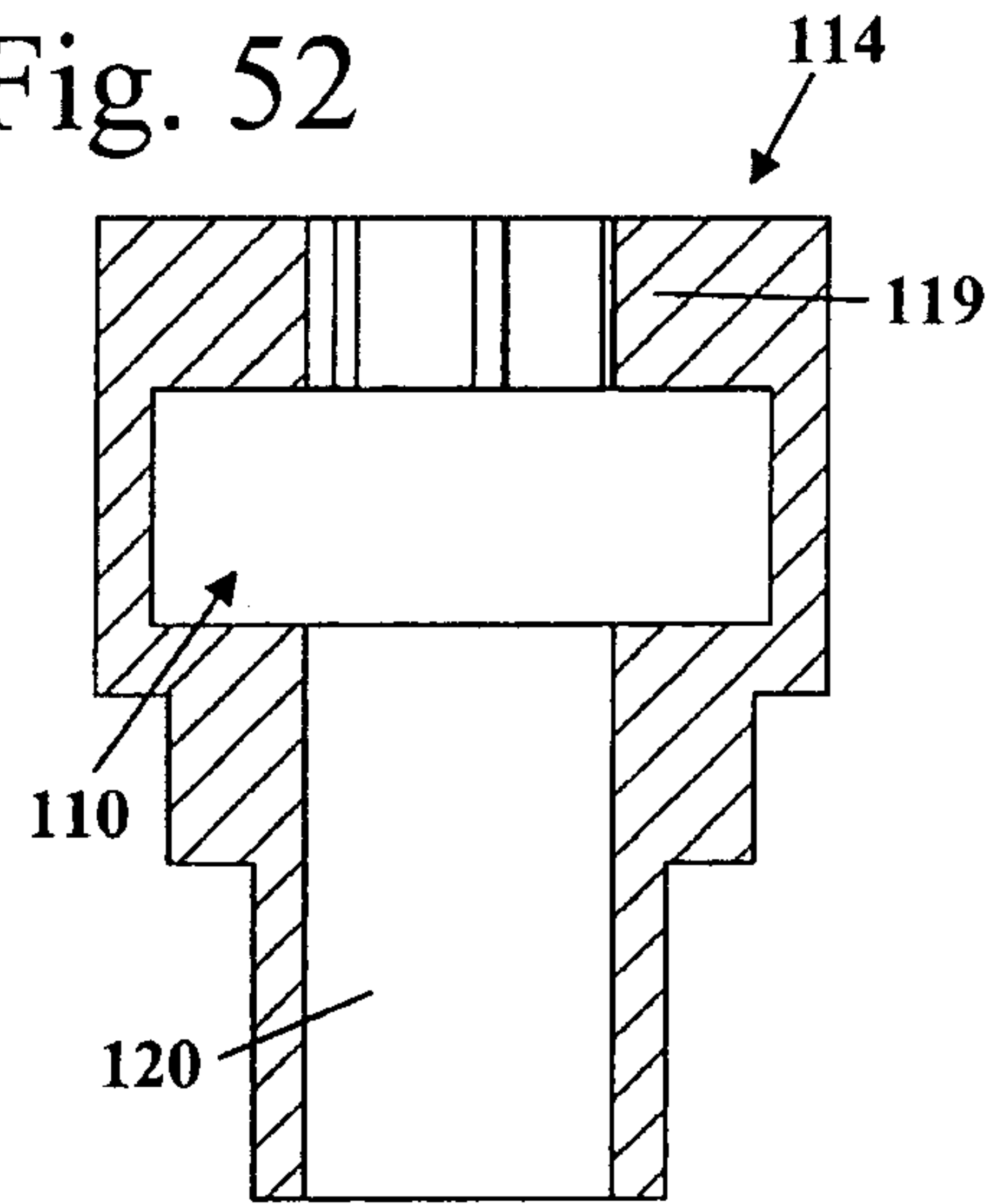

Fig. 53

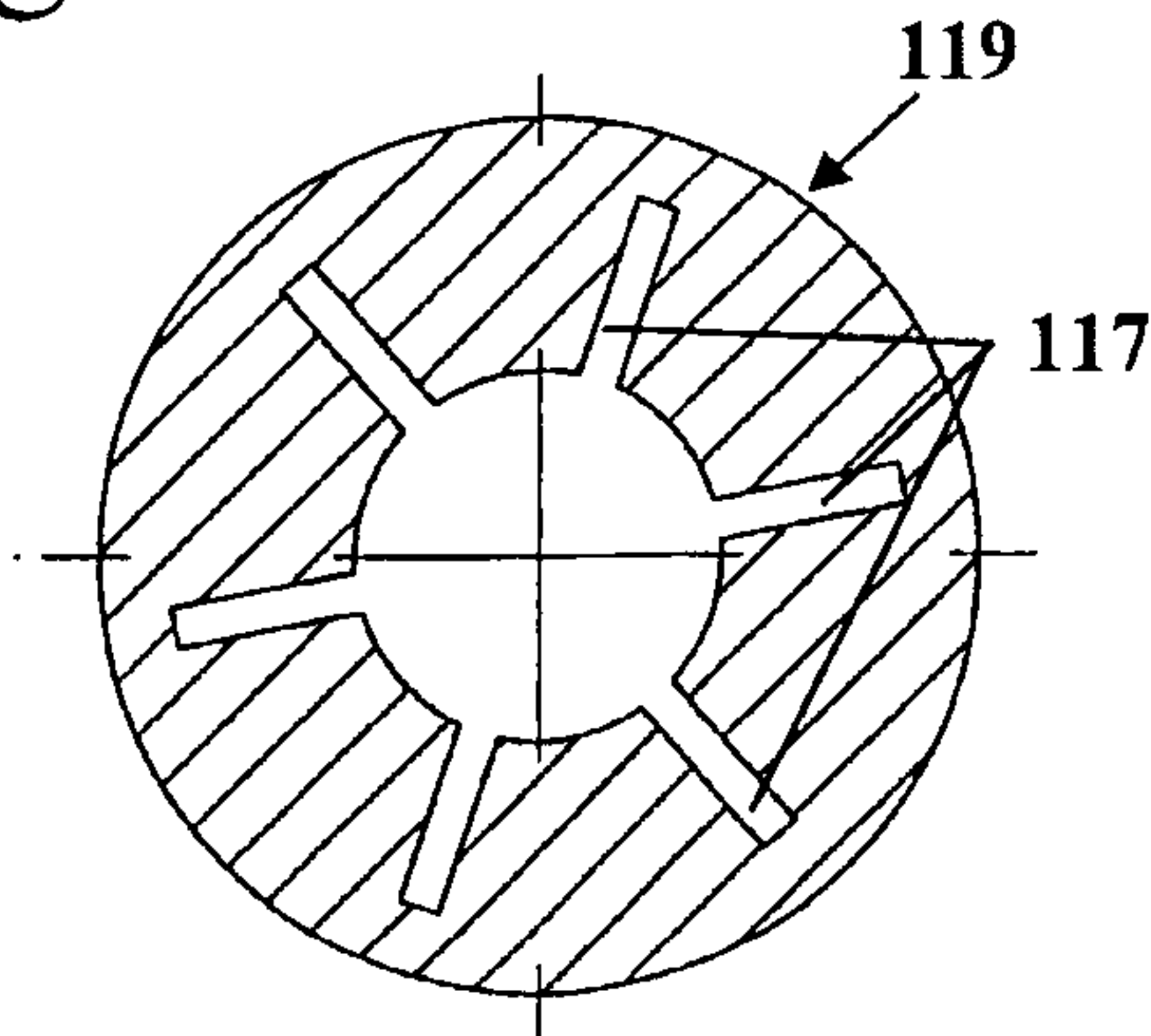

Fig. 54

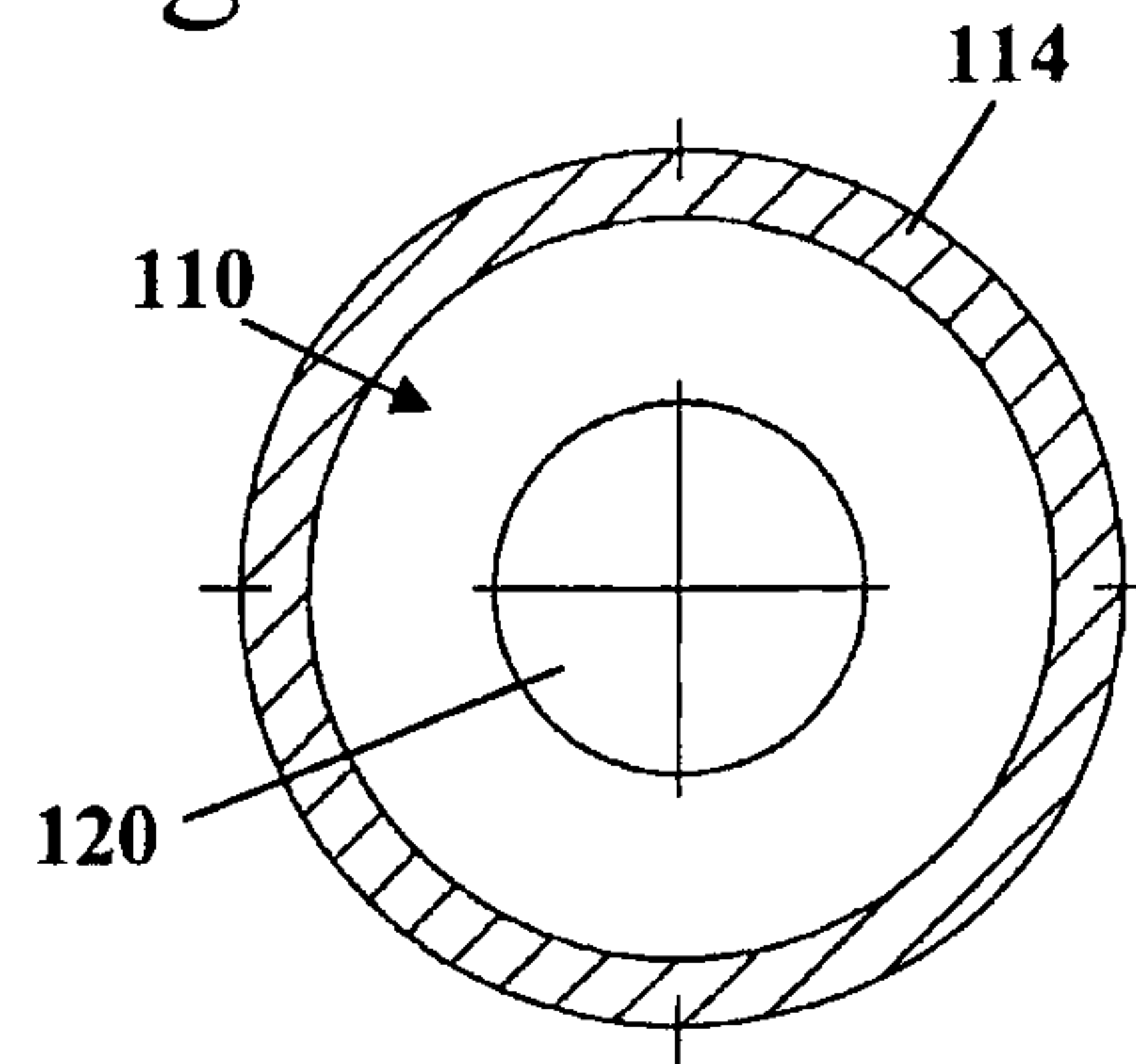

Fig. 2

