

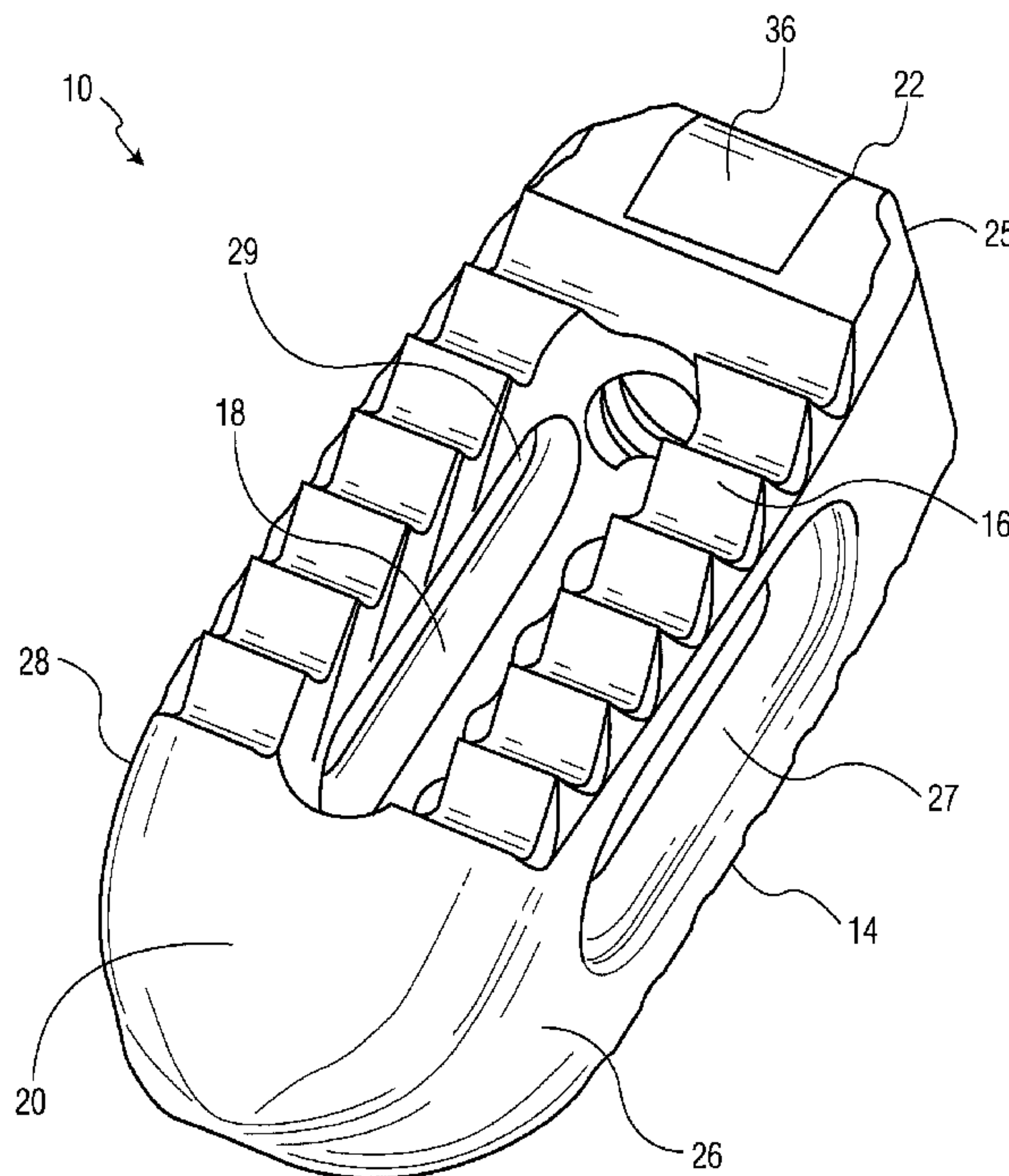

(22) Date de dépôt/Filing Date: 2016/01/13
(41) Mise à la disp. pub./Open to Public Insp.: 2016/07/14
(45) Date de délivrance/Issue Date: 2018/11/20
(30) Priorité/Priority: 2015/01/14 (US62/103,276)

(51) Cl.Int./Int.Cl. *A61F 2/44* (2006.01),
A61B 17/70 (2006.01), *A61L 27/06* (2006.01)
(72) Inventeurs/Inventors:
WILLIS, STEVEN, US;
ZIELINSKA, JUSTYNA, US
(73) Propriétaire/Owner:
STRYKER EUROPEAN HOLDINGS I, LLC, US
(74) Agent: GOWLING WLG (CANADA) LLP

(54) Titre : IMPLANT VERTEBRAL DOTE DE SURFACES POREUSES ET DE SURFACES SOLIDES
(54) Title: SPINAL IMPLANT WITH POROUS AND SOLID SURFACES



(57) **Abrégé/Abstract:**

A spinal implant including porous and solid portions is disclosed. The implant includes porous portions on upper and lower surfaces and in an interior thereof. Methods of manufacturing and implanting such implants are also disclosed.

ABSTRACT

A spinal implant including porous and solid portions is disclosed. The implant includes porous portions on upper and lower surfaces and in an interior thereof. Methods of manufacturing and implanting such implants are also disclosed.

SPINAL IMPLANT WITH POROUS AND SOLID SURFACES

BACKGROUND OF THE INVENTION

[0001] The present invention relates to spinal surgery, namely, implants utilized in fusing adjacent intervertebral bodies or the replacement of a vertebral body.

[0002] Back pain can be caused by many different maladies, not the least of which are problems that directly impact the intervertebral discs of the spine. Typical disc issues include, *inter alia*, degeneration, bulging, herniation, thinning and abnormal movement. One method of treatment of such disc problems that has been widely utilized in the field of spinal surgery is a spinal fusion procedure, whereby an affected disc is removed, and the adjacent vertebral bodies are fused together through the use of interbody spacers, implants or the like. In some instances, it may also be necessary to remove and replace an entire vertebral body. This is often accomplished through the use of a larger implant that acts to fuse together the vertebral bodies adjacent the removed vertebral body.

[0003] The aforementioned implants often rely upon mechanical features to ensure engagement between the devices and the bone of the existing vertebral bodies. This coupled with the normal compressive load of the spine acts to keep the implant in place until bone can grow from the existing vertebral bodies into and through the implant. To encourage the bone growth, the implants are often pre-loaded with bone growth promoting material and thereafter placed into the spine. Bone growth promoting material may include naturally occurring bone, artificial materials or the like.

[0004] To further ensure a strong implant-bone connection, some existing implants include an area formed of porous material that allows bone to grow into it. Although there is little doubt that the bone growth into the implant is beneficial in maintaining an implant in place, these implants are often very difficult (and thusly, expensive) to manufacture. Additionally, existing implants that implement porous material do so in a limited manner. Often times, because of manufacturing or strength concerns or the like, the porous material is limited to a

thin layer covering the upper and lower surfaces of the implant, which only allows for a small amount of bone to grow into the implant.

[0005] Therefore, there exists a need for an improved spinal implant that employs a significant amount of porous material, yet remains cost efficient and maintains the necessary strength required of a spinal implant.

BRIEF SUMMARY OF THE INVENTION

[0006] A first aspect of the present invention is a spinal implant including an upper surface including a first porous portion and first solid portion, a lower surface including a second porous portion and a second solid portion and a cavity formed through the upper and lower surfaces, the cavity including a third porous portion.

[0007] Other embodiments according to the first aspect may include a nose having a solid exterior, a hollow area and a porous region. At least one serration may be included on each of the upper and lower surfaces. The serration(s) may include a solid tip, a solid root and a porous section. The implant may further include first and second side walls extending between the upper and lower surfaces, the side walls including a solid exterior surface and a porous interior surface. The first and second side walls may each include lateral windows. The lateral windows may reduce the stiffness of the implant and may be tapered. The implant may also include a threaded opening at a rear end. Implants according to the present invention may be constructed of any material suitable for implantation in the body of a patient, for instance, a metal such as titanium. The implants can be configured for insertion from various aspects, *e.g.*, a posterior approach, a lateral approach or an anterior approach. The implant may include a nose that facilitates the insertion of the implant in a first orientation and rotation to a second orientation. The implant may be constructed from an additive manufacturing process, and may be machined to create smooth surfaces.

BRIEF DESCRIPTION OF THE DRAWINGS

[0008] A more complete appreciation of the subject matter of the present invention and of the various advantages thereof can be realized by reference to the following detailed description in which reference is made to the accompanying drawings in which:

[0009] Figure 1 is a front perspective view of an implant according to one embodiment of the present invention.

[0010] Figures 2A and 2B are rear perspective views of the implant of figure 1.

[0011] Figure 3 is a side view of the implant of figure 1.

[0012] Figures 4A and 4B are top views of the implant of figure 1.

[0013] Figure 5 is a rear view of the implant of figure 1.

[0014] Figure 6 is a cross-sectional view of the implant of figure 1 take along line 6-6 of figure 5.

[0015] Figure 7 is an enlarged cross-sectional view of serrations of the implant of figure 1.

[0016] Figures 8A-8B are cross-sectional views of the implant of figure 1 take along lines 8A-8A and 8B-8B of figures 4A and 4B, respectively.

[0017] Figures 9A-9C are views illustrating a constructed version of the implant of figure 1.

[0018] Figure 10 is a fluoroscopic view of an implanted implant of figure 1.

[0019] Figures 11A-11C are views of implants according to other embodiments of the present invention.

[0020] Figures 12A-12C are views of implants according to other embodiments of the present invention.

[0021] Figures 13A-13B are views of implants according to other embodiments of the present invention.

[0022] Figures 14A-14B are views of implants according to other embodiments of the present invention.

[0023] Figures 15A-15C are views of implants according to other embodiments of the present invention.

[0024] Figure 16 depicts yet another implant according to another embodiment of the present invention.

DETAILED DESCRIPTION

[0025] An implant 10 according to a first embodiment of the present invention is depicted in Figures 1-10. Implant 10 is shown as an implant suitable for implantation from a posterior approach. However, as will be readily apparent from the below discussion pertaining to other embodiments, the present invention is not limited to any particular type of implant design. Rather, it is contemplated that certain features of the present invention can be implemented in different types of implants. For instance, implants according to the present invention can be adapted for implantation from anterior or lateral aspects of the patient, as will be discussed below. Moreover, although disclosed as being constructed of metallic materials, it is contemplated that implants according to the present invention may be constructed of polymeric materials such as PEEK or the like. Additionally, each of the embodiments shown

in the drawings are designed for placement between adjacent vertebral bodies. However, it is contemplated that implants in accordance with the present invention may be designed for use as vertebral body replacements.

[0026] Implant 10 is shown including upper and lower surfaces 12 and 14, respectively. Each surface includes a plurality of serrations 16 at least covering a portion of the surface. While a specific serration design is depicted in the drawings and described in more detail below, many different serration designs can be employed. Implant 10 also includes a cavity 18 formed through a central portion of the implant and each of surfaces 12 and 14. Cavity 18 can be sized and shaped differently from what is shown and can be located in other locations of implant 10. Cavity 18 is preferably designed so that bone growth promoting materials can be contained therein to promote bone growth through the implant.

[0027] Implant 10 also includes a wedge nose 20, a rear end 22 with a threaded opening 24 and a chamfer interface 25, and sidewalls 26 and 28 through which lateral windows 27 and 29, respectively are formed. Wedge nose 20 is sized and shaped so as to distract vertebral bodies during insertion of the implant into the intervertebral space. Threaded opening 24 and chamfer interface 25 are configured to cooperate with an insertion tool (not shown in detail). Lateral windows 27 and 29 act to both reduce the stiffness of implant 10 and allow for visualization through the lateral aspect of the implant under fluoroscopy imaging. Of course, the specific sizes and shapes of these elements may vary in other embodiment implants in accordance with the present invention, including certain embodiments discussed below. For instance, certain of the surfaces of implant 10 are shown as smooth and rounded to reduce the potential for soft tissue damage during an implantation procedure, but can be configured differently.

[0028] Implant 10 is formed of both solid and porous portions. The porous portions are located on upper and lower surfaces 12, 14, as well as on certain of the internal surfaces of the implant, which allows for bone to grow into a significant portion of the implant. This can best be seen in Figures 2B, 4B, 8B, and 9A-9C, where the porous surfaces of implant 10 are shown with different shading. In one embodiment, the porous surfaces have an average pore diameter between 100-1000 microns with a 30-80% porosity, while a preferred embodiment would have a porosity between 55-65%. The porous surfaces may also have any thickness, for instance between 500-4500 microns, and preferably between 500-1500 microns. This results in a surface that is both strong enough for use in a spinal implant and maximizes bone

growth potential. The porous portions of implant 10, as well as the solid portions, can be created through the use of a 3D printing process such as is disclosed in U.S. Patent Nos. 7,537,664 and 8,147,861; U.S. Patent Application Publications Nos. 2006/0147332, 2007/0142914, 2008/0004709; and U.S. Patent Application Serial Nos. 13/441,154 and 13/618,218. It is also contemplated to form any porous portion via another known or hereafter developed procedure, such as laser etching.

[0029] With specific reference to Figures 2B, 4B and 6-8B, the location of the porous and solid portions of implant 10 will be discussed. In the solid model views of Figures 2B and 4B, the porous portions of the implant are shown as darker sections, while the solid portions are depicted in lighter material. The cross-sectional views of Figures 6-8B on the other hand depict these portions with different cross hatching. For instance, nose 20 includes a solid, smooth exterior construction. The use of solid metal in this section allows for it to withstand impaction loads during an insertion process, as well as for visualization of its location under fluoroscopy or other imaging. It is shown in Figure 6 that nose 20 in actuality includes a solid portion 30, a hollow area 32 and a porous region 34. Solid portion 30 is designed to provide the necessary support discussed above, while hollow area 32 is provided in order to decrease the radioopacity of the nose and improve visualization under fluoroscopy imaging. Porous region 34, as will be discussed more fully below, extends into the area within cavity 18. It is contemplated that in other embodiments, porous region 34 may extend partially or completely into hollow area 32. This still acts to decrease the radioopacity of the nose, which improves visualization, but also improve the cleanability, sterilization and powder removal from the implant during processing.

[0030] Like nose 20, a significant portion of rear end 22 is formed of solid material, so as to facilitate a strong connection with an insertion tool (not shown in detail). In particular, it is noted that while certain portions of the upper and lower surfaces 12, 14 at the rear end are porous, sections 36 are formed solid as they overlie threaded opening 24. This construction adds the necessary stability to the opening that is required for a solid connection with the insertion tool. Moreover, side walls 26, 28 are, as is best shown in Figures 8A and 8B, formed solid on an exterior of implant 10 and porous in an interior thereof. Specifically, with reference to Figure 8B, the side walls include solid portions 38 and porous portions 40. Again, the inclusion of solid portions 38 provides stability to implant 10. However, as is mentioned above, lateral windows 27, 29 reduce the stiffness of the implant. Solid portions 38 may be any thickness, for instance, within the range of 0.25mm to 0.5mm. The solid portions also serve to

mentioned above, lateral windows 27, 29 reduce the stiffness of the implant. Solid portions 38 may be any thickness, for instance, within the range of 0.25mm to 0.5mm. The solid portions also serve to provide a smooth exterior surface to the implant, which reduces tissue damage during implantation. It is noted that in certain embodiments, material may be machined off of any of the surfaces to create a smooth surface finish, which may further prevent tissue damage during implantation. This is especially true in connection with implanted formed by 3D printing processes, as such often result in even solid portions having a rougher surface finish.

[0031] Aside from the above discussed portions that are formed solid, the majority of the remainder of implant 10 is formed porous. Most notably, upper and lower surfaces 12, 14 are largely porous, especially in the portions having serrations 16. However, the serrations themselves include some solid portions. With reference to figures 6 and 7, serrations 16 include solid tips 40 and solid roots 42, with the remainder of their construction including porous sections 44. Solid tips 40 not only provide a strong leading surface for engagement with bone, but also prevent fracture of a porous surface from occurring upon such engagement. Specifically, since the individual components (*e.g.*, struts) of the porous surfaces of implant 10 may not necessarily converge to a point, they may fracture upon application of a force like what would be transmitted to serrations 16 during implantation. Solid core 42 also acts to strengthen serrations 16, by essentially providing a strong foundation for porous sections 44.

[0032] The particular shape of serrations 16 is also designed to create a strong initial implant-bone connection, while also allowing for easy insertion of implant 10 into the space between vertebrae. In order to resist back-out of implant 10, serrations 16 are oriented at an angle 46 (*see* figure 7). This angle may be any value, although a value within the range of 60 to 80 degrees is preferable. The angle 48 (*see* figure 7) of solid tips 40 is preferably in the range of 30 to 50 degrees. The height 50 of serrations 16 may be within the range of 0.5mm to 1.5mm, while the height 52 of solid tips 40 is dependent upon height 50, but preferably is within the range of 0.25mm to 0.5mm. Solid core 42 has a thickness 54, preferably 0.1mm to 0.3mm thick. The overall pitch 56 of serrations 16 is preferably between 1.25mm and 2mm.

[0033] The interior of cavity 18 is largely constructed of porous material, which allows for bone growth in this section as well, and hence fusion through implant 10. This construction has the added benefit of also reducing stiffness of the implant, like lateral windows 27, 29. A

fully constructed implant 10 is depicted in Figures 9A-9C. As shown, the various solid and porous portions of the implant appear differently to the naked eye. The particular prototype shown in those figures was created via a 3D printing process referred to as additive manufacturing, utilizing a titanium material. Figure 10 is a fluoroscopic image of implant 10 while in position between two adjacent vertebral bodies. In the particular image shown there, implant 10 is engaged with an insertion tool 60, although the specifics of that tool cannot be seen.

[0034] Figures 11A-11C depict different embodiment implants 110, 210 and 310, respectively that are each suitable for implantation from a posterior approach, like implant 10. Figures 12A-12C depict different embodiment implants 410, 510 and 610, respectively that are each suitable for implantation from a lateral approach. Figures 13A-13B depict an implant 710 suitable for implantation from a posterior lateral approach. Figures 14A-14B depict an implant 810 suitable for implantation from an anterior approach. Among other ways, those implants differ from implant 10 and each other in the manner in which their solid and porous portions are dispersed throughout the design. Again, solid portions are shown in lighter shading and porous portions are shown in darker shading. These various implant embodiments demonstrate that implants in accordance with the present invention may vary both in their size and shape, as well as in the configuration of their porous and solid portions.

[0035] Figures 15A-15C depict an implant 910 similar to that of implant 10, albeit with certain specific differences. For instance, nose 920 includes sidewalls (best shown in Fig. 15A) that exhibit an increased angle from that of nose 20. This particular design allows for the implant to be inserted in an orientation that is rotated ninety degrees from the traditional insertion orientation of such an implant. Thereafter, implant 910 is rotated, which may result in an additional distraction from that of the initial insertion. Implant 910 may also be provided with a feature, such as a dimple or the like (not shown), that helps to identify the correct final orientation of the implant. For instance, a dimple may be provided at rear end 922 so that the surgeon may easily identify the final orientation of the implant. Of course, any visual identifier could also be employed.

[0036] Implant 910 also includes differently shaped/oriented lateral windows 927, 929 (only window 929 is shown in Fig. 15B) from that of above-discussed windows 27, 29. As shown, windows 927, 929 extend along less of implant 910 than do windows 27, 29 along implant 10. Moreover, the height of windows 927, 929 taper in the same direction as does the height

of implant 910. For implants that are not lordotic, the windows may be a constant height. Finally, implant 910 exhibits chamfered edges 923 (best shown in Fig. 15C) that are on the four sides of the implant to eliminate sharp edges and make the implant more suitable for implantation without tissue damage.

[0037] Figure 16 depicts yet another embodiment according to the present invention, cervical implant 1010. This implant is particularly suited for implantation in a cervical area of the spine and includes many elements similar to those of the other embodiment implants. For instance, implant 1010 includes upper and lower surfaces 1012, 1014 which include serrations 1016 similar to those discussed above. Further, the cervical implant includes a tapered nose or leading end 1020 and a trailing end 1022 with an aperture 1024 for engaging an insertion tool. Although other embodiments may vary, implant 1010 is shown as having porous portions at the upper and lower surfaces 1012, 1014 that are similar to those discussed above.

[0038] In use, the various implants in accordance with the present invention may be implanted in a manner similar to existing spinal implants. For instance, an insertion tool (*e.g.*, tool 60) may be coupled with the implant to guide the implant into place between vertebral bodies. Initial engagement of the implant with the vertebral bodies is achieved via mechanical coupling elements included on the implant (*e.g.*, serrations 16). Thereafter, bone is permitted to grow into any porous sections on the implant. This bone growth may be promoted through the use of bone growth promoting substances, such as allograft materials placed within cavity 18. After some time, the porosity of the implant preferably allows for a stronger fusion than that of existing, nonporous implants.

[0039] In creating an implant such as implant 10, the aforementioned 3D printing process can be utilized (*see e.g.*, Figures 9A-9C). Because of the construction of the implant, it may be beneficial to orient the construction in one manner or the like. For instance, it has been found that orienting the build so that nose 20 faces down (*i.e.*, is built first) results in better serration 16 creation. Of course, the nose down orientation is only one of many that can be employed and the creation of implants according to the present invention is not to be so limited.

[0040] Although the invention herein has been described with reference to particular embodiments, it is to be understood that these embodiments are merely illustrative of the principles and applications of the present invention. It is therefore to be understood that numerous modifications may be made to the illustrative embodiments and that other

arrangements may be devised without departing from the spirit and scope of the present invention as defined by the appended claims.

CLAIMS

1. A spinal implant comprising:
an upper exterior surface including a first porous portion and first solid portion;
a lower exterior surface including a second porous portion and a second solid portion; and
a cavity formed through the upper exterior and lower exterior surfaces, the cavity being substantially defined by a third porous portion.
2. The spinal implant of claim 1, further including a nose having a solid exterior, an inner porous region and a hollow area disposed therebetween.
3. The spinal implant of claim 1, further including at least one serration on each of the upper and lower surfaces, the at least one serration including a solid tip, a solid root and a porous section.
4. The spinal implant of claim 1, further including first and second side walls extending between the upper exterior and lower exterior surfaces, the side walls including a solid exterior surface and a porous interior surface.
5. The spinal implant of claim 4, wherein the first and second side walls each include lateral windows.
6. The spinal implant of claim 5, wherein the lateral windows reduce the stiffness of the implant.
7. The spinal implant of claim 6, wherein the lateral windows taper.
8. The spinal implant of claim 1, further comprising a threaded opening at a rear end.
9. The spinal implant of claim 1, wherein the implant is constructed of a metal.
10. The spinal implant of claim 9, wherein the metal is titanium.

11. The spinal implant of claim 1, wherein the implant is configured for insertion from a posterior approach, a lateral approach or an anterior approach.

12. The spinal implant of claim 1, further including a nose that facilitates the insertion of the implant in a first orientation and rotation to a second orientation.

13. The spinal implant of claim 12, wherein the nose has a solid exterior.

14. The spinal implant of claim 1, wherein the implant is constructed from an additive manufacturing process.

15. The spinal implant of claim 14, wherein the implant is machined to create smooth surfaces.

16. A spinal implant comprising:
an upper exterior surface including a first porous portion and first solid portion;
a lower exterior surface including a second porous portion and a second solid portion;
a cavity formed through the upper and lower surfaces, the cavity including a third porous portion; and
first and second side walls extending between the upper exterior and lower exterior surfaces, the side walls including a solid exterior surface and a porous interior surface, the first and second side walls each include tapering lateral windows to reduce the stiffness of the implant.

#1769726

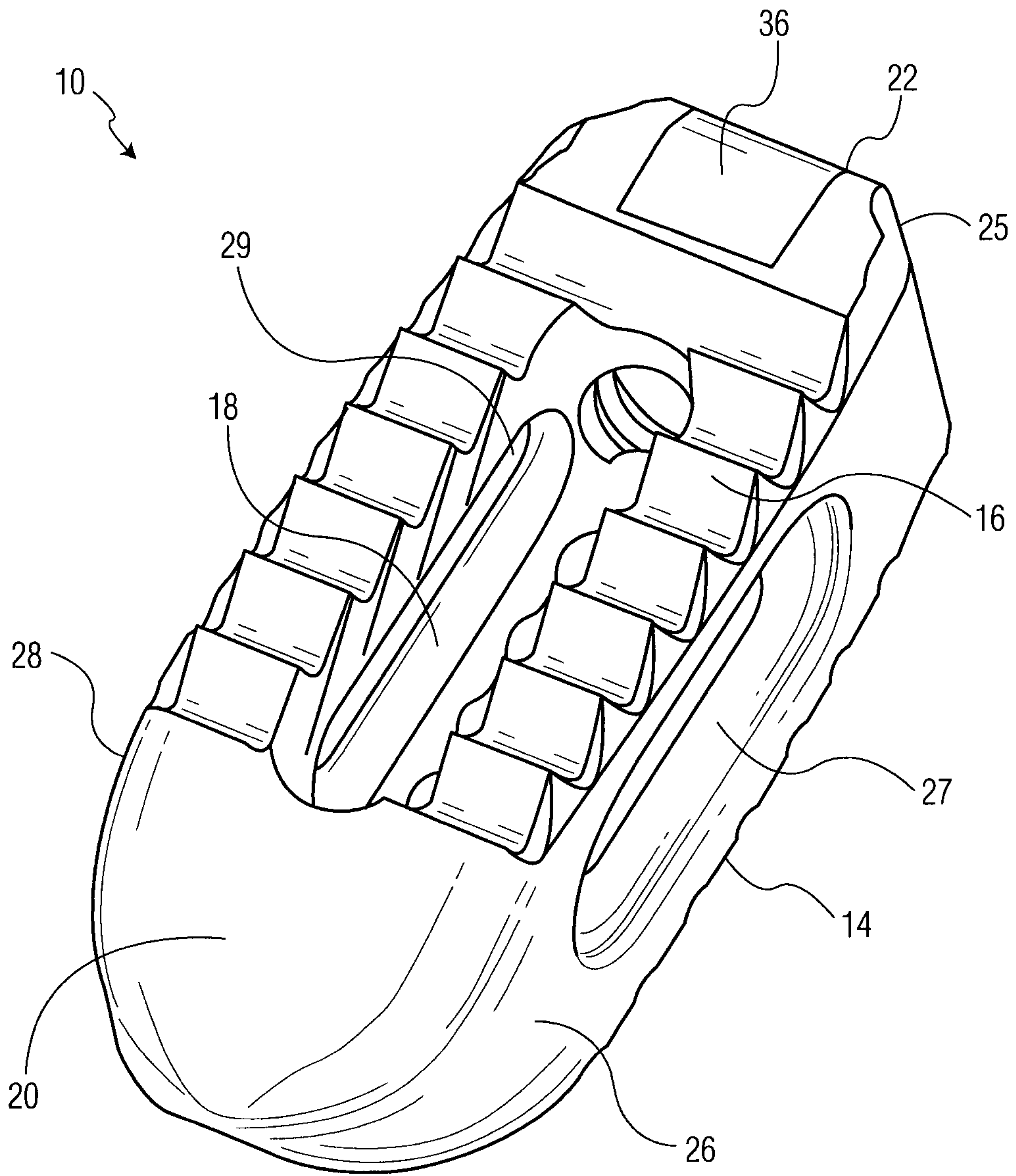

FIG. 1

2/15

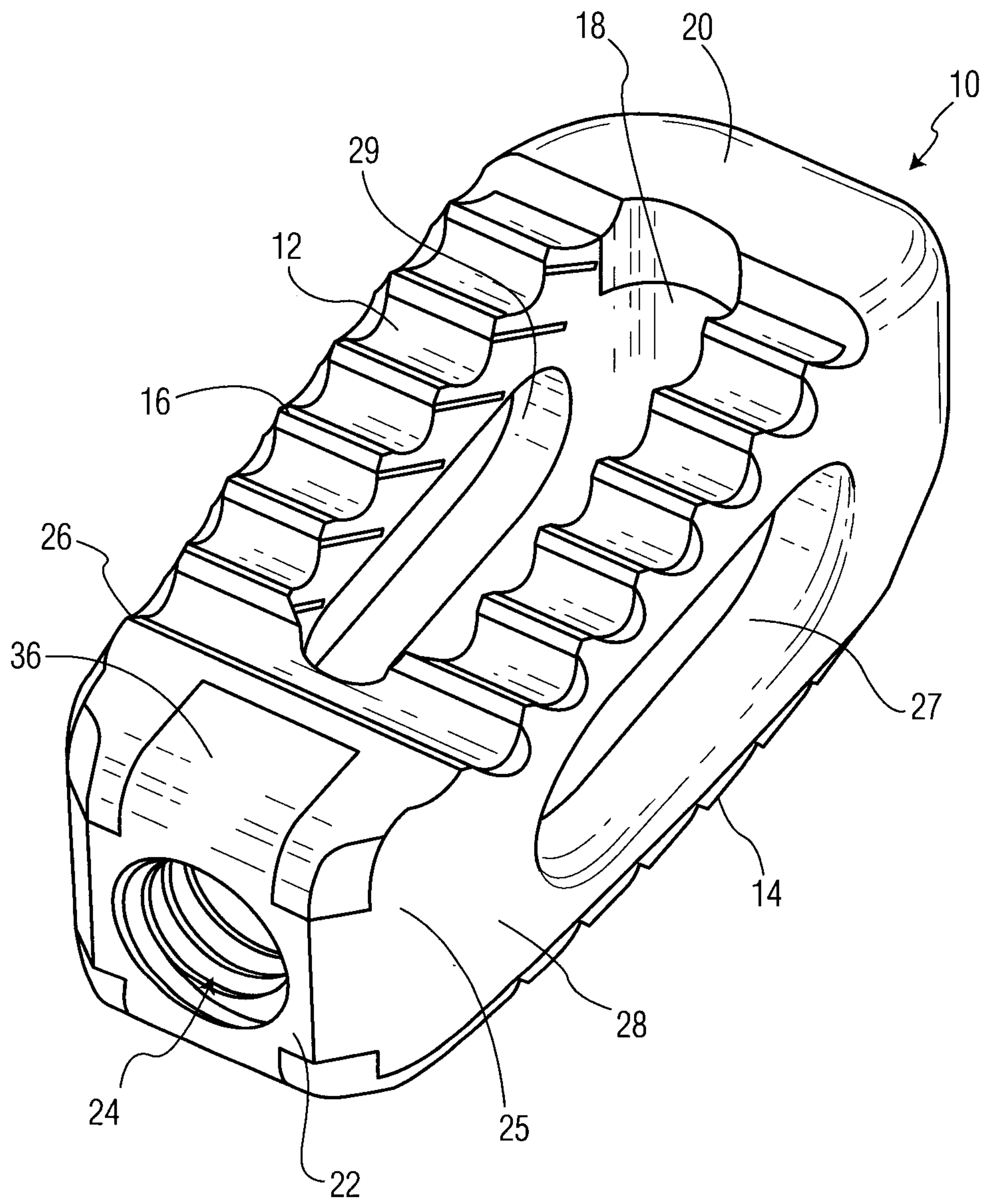

FIG. 2A

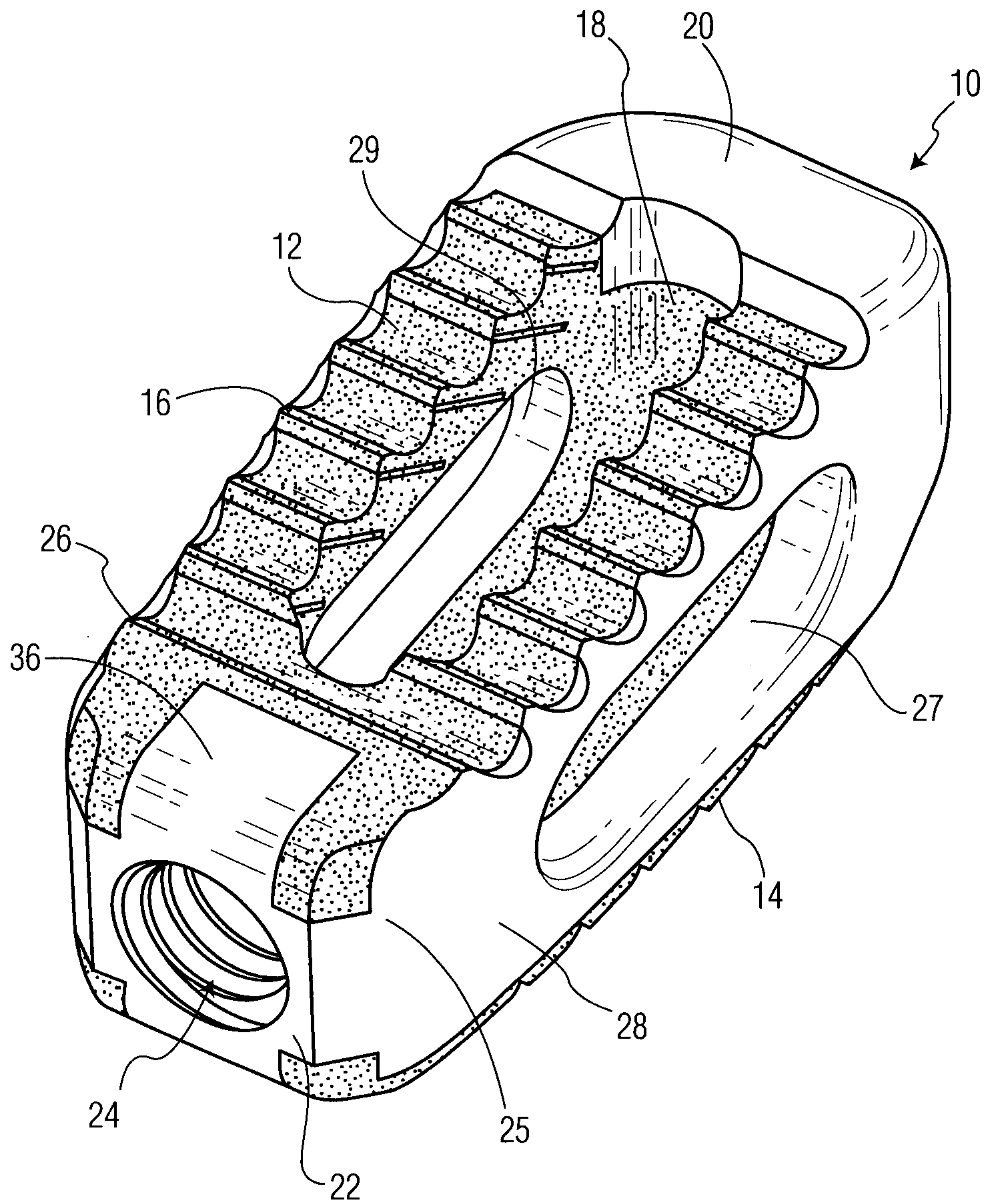
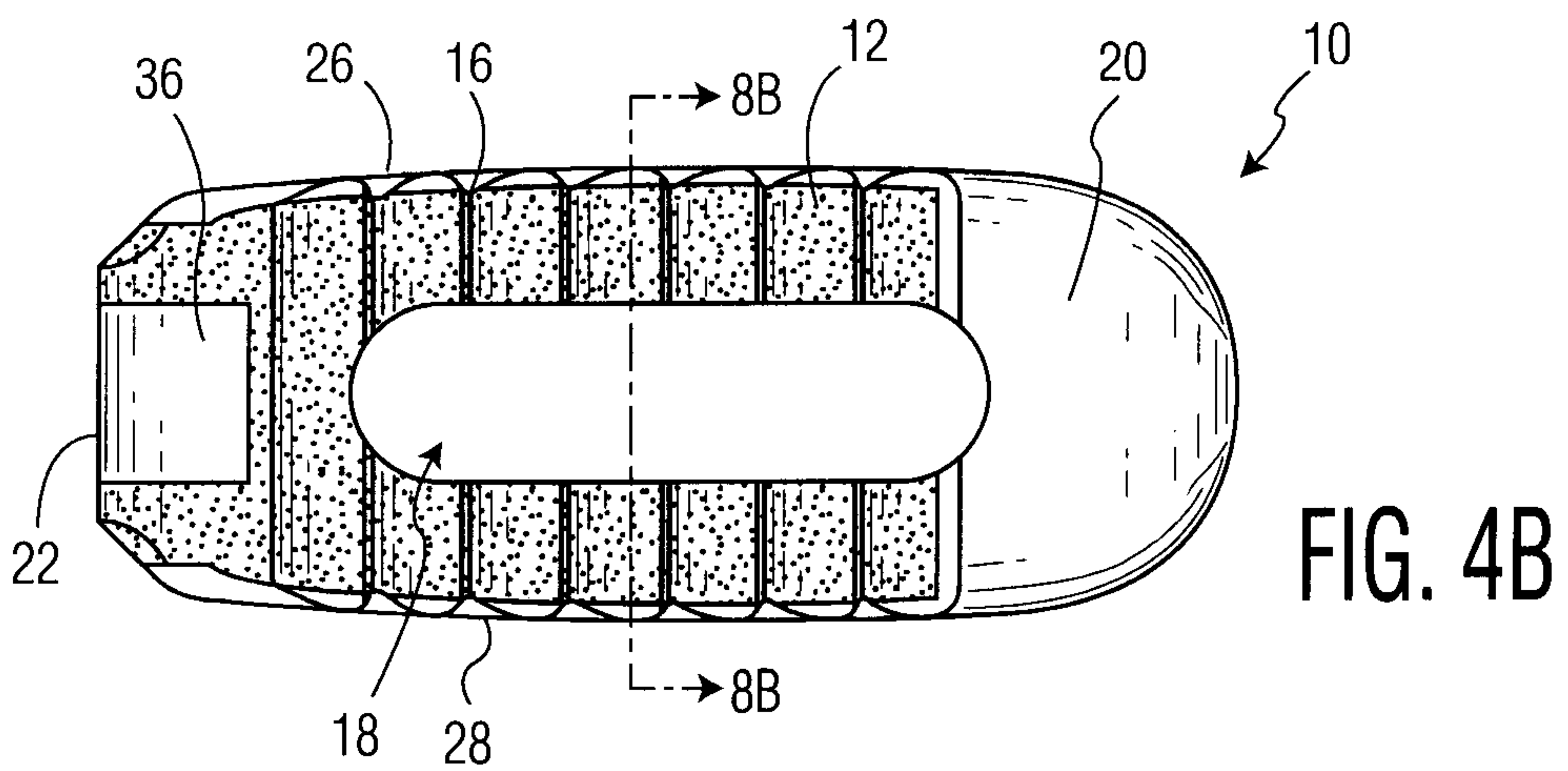
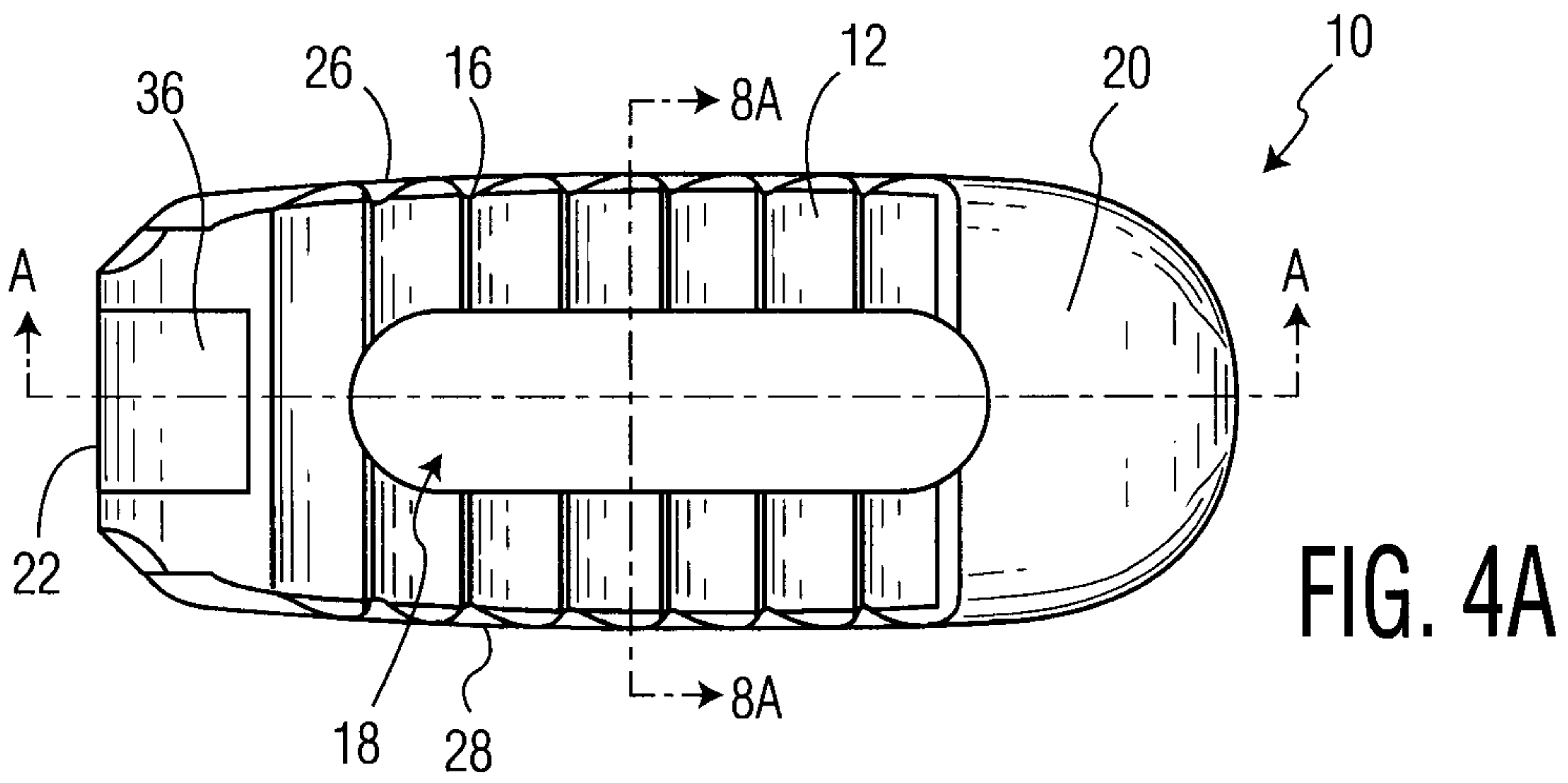
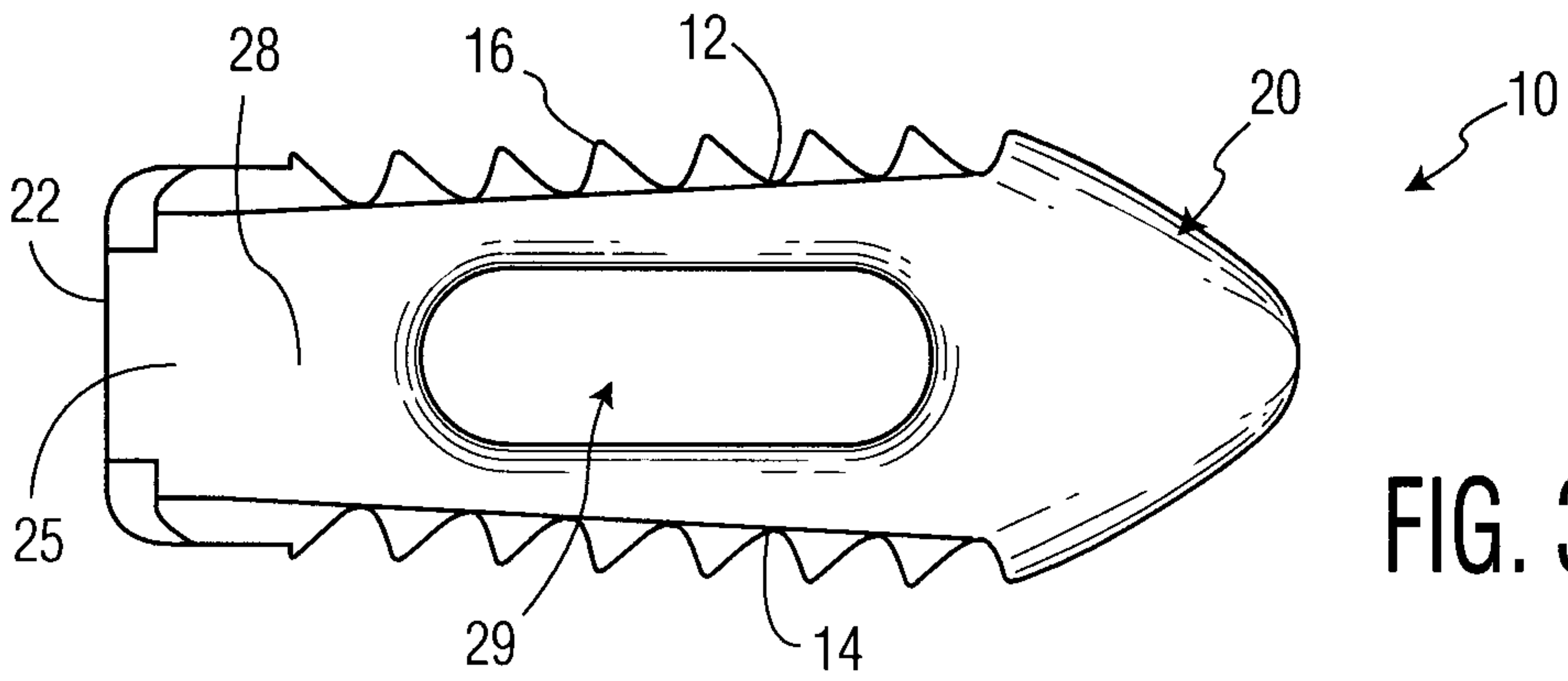

FIG. 2B

4/15



5/15

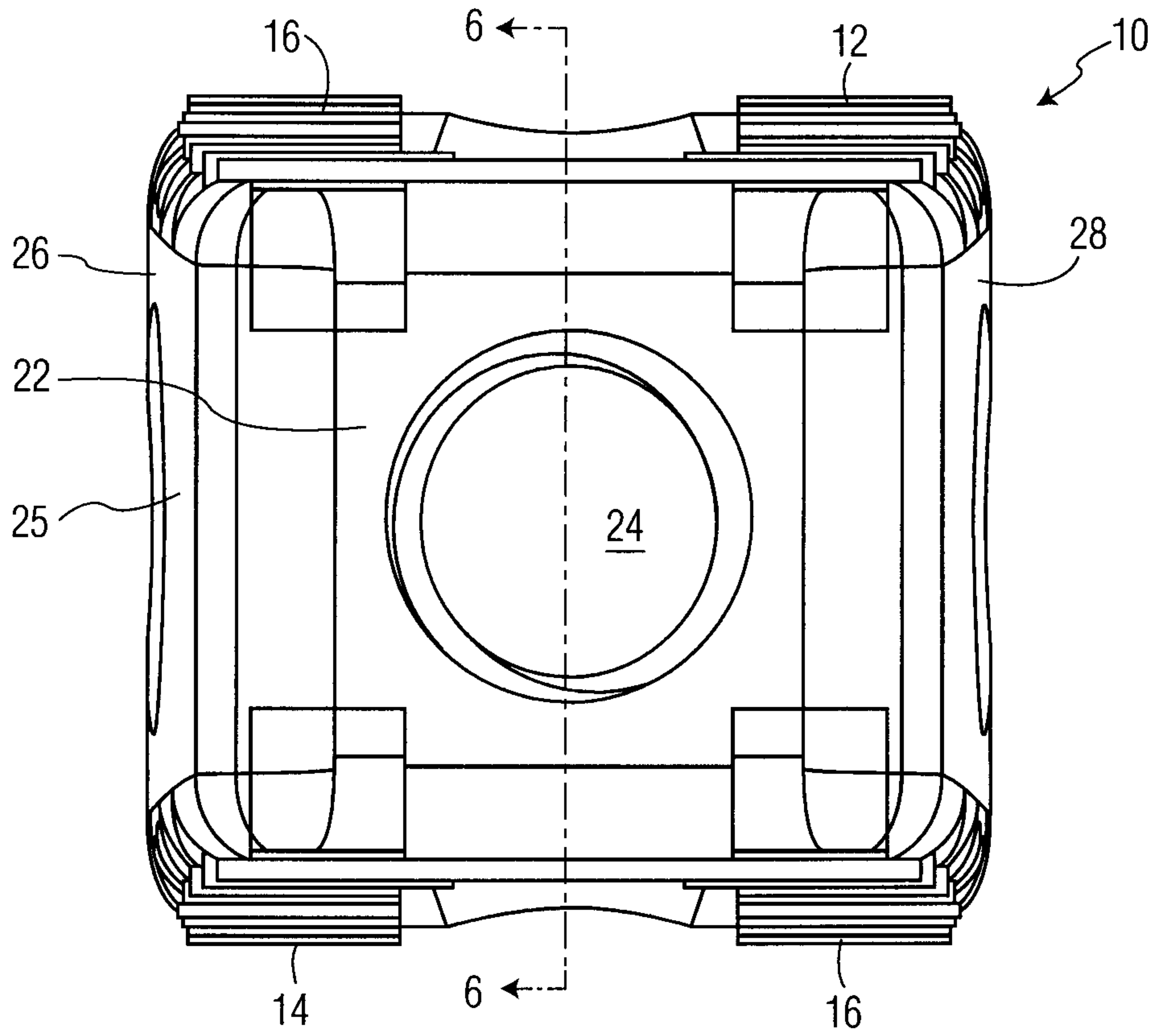

FIG. 5

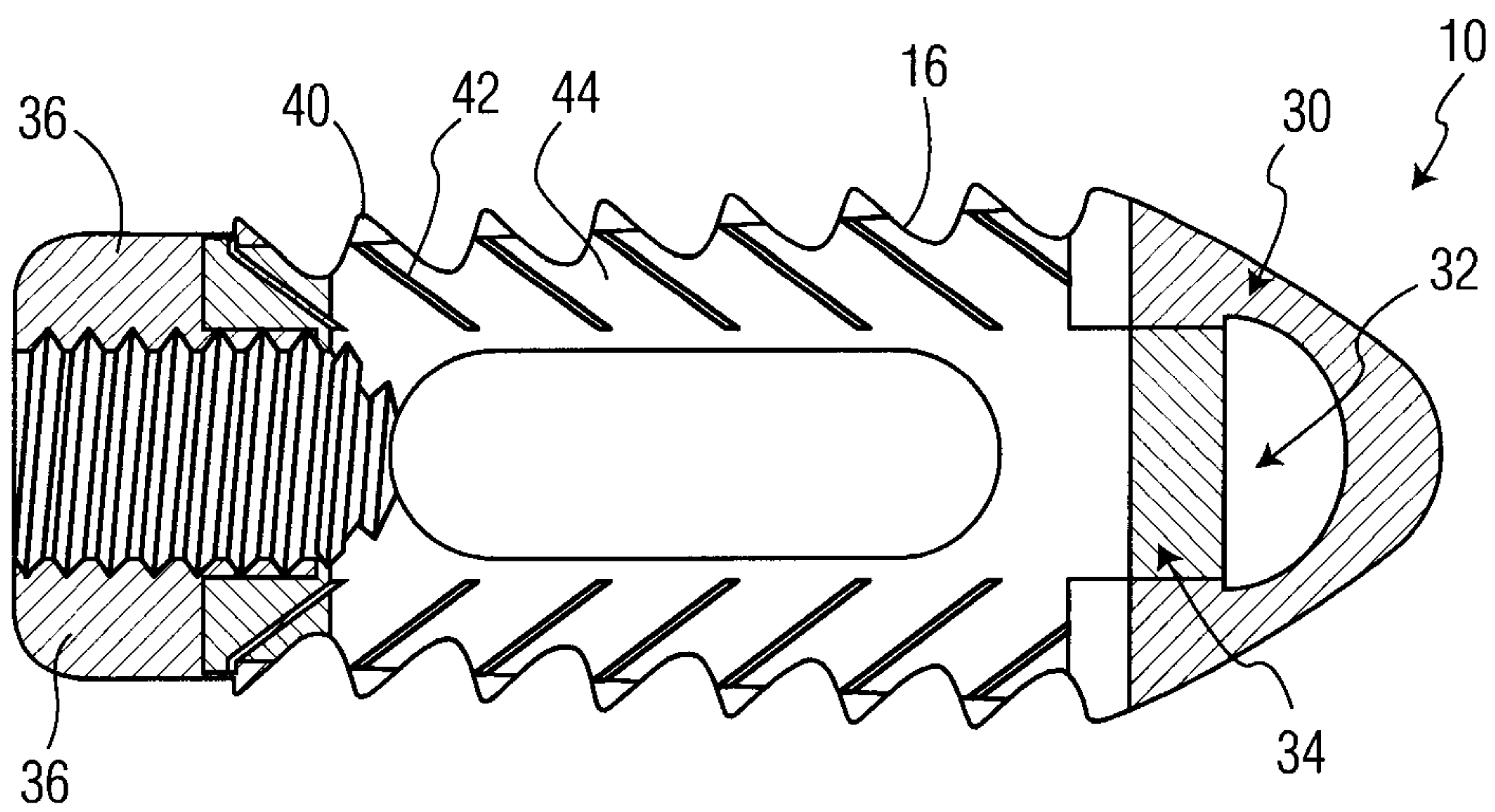

FIG. 6

6/15

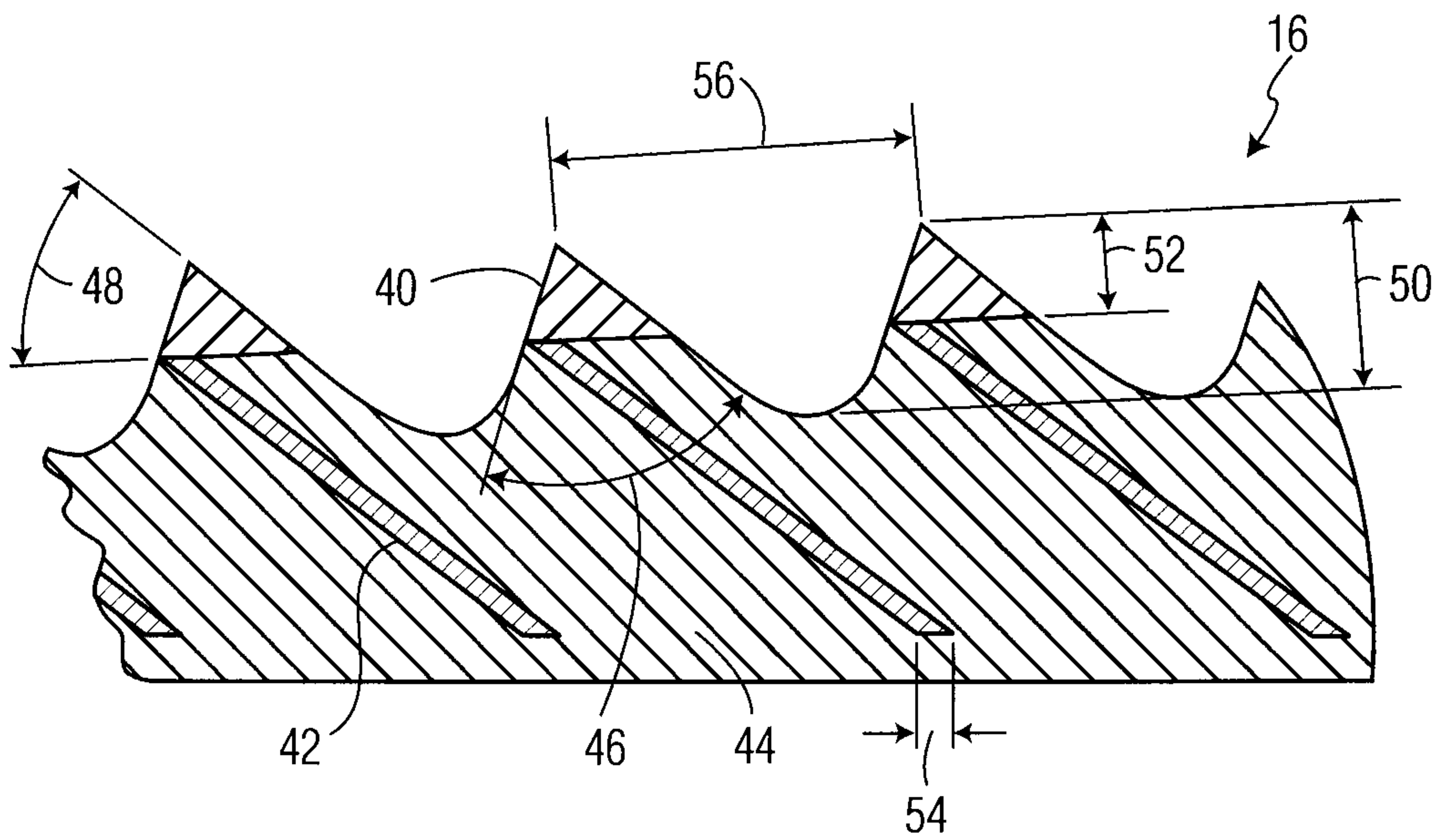

FIG. 7

7/15

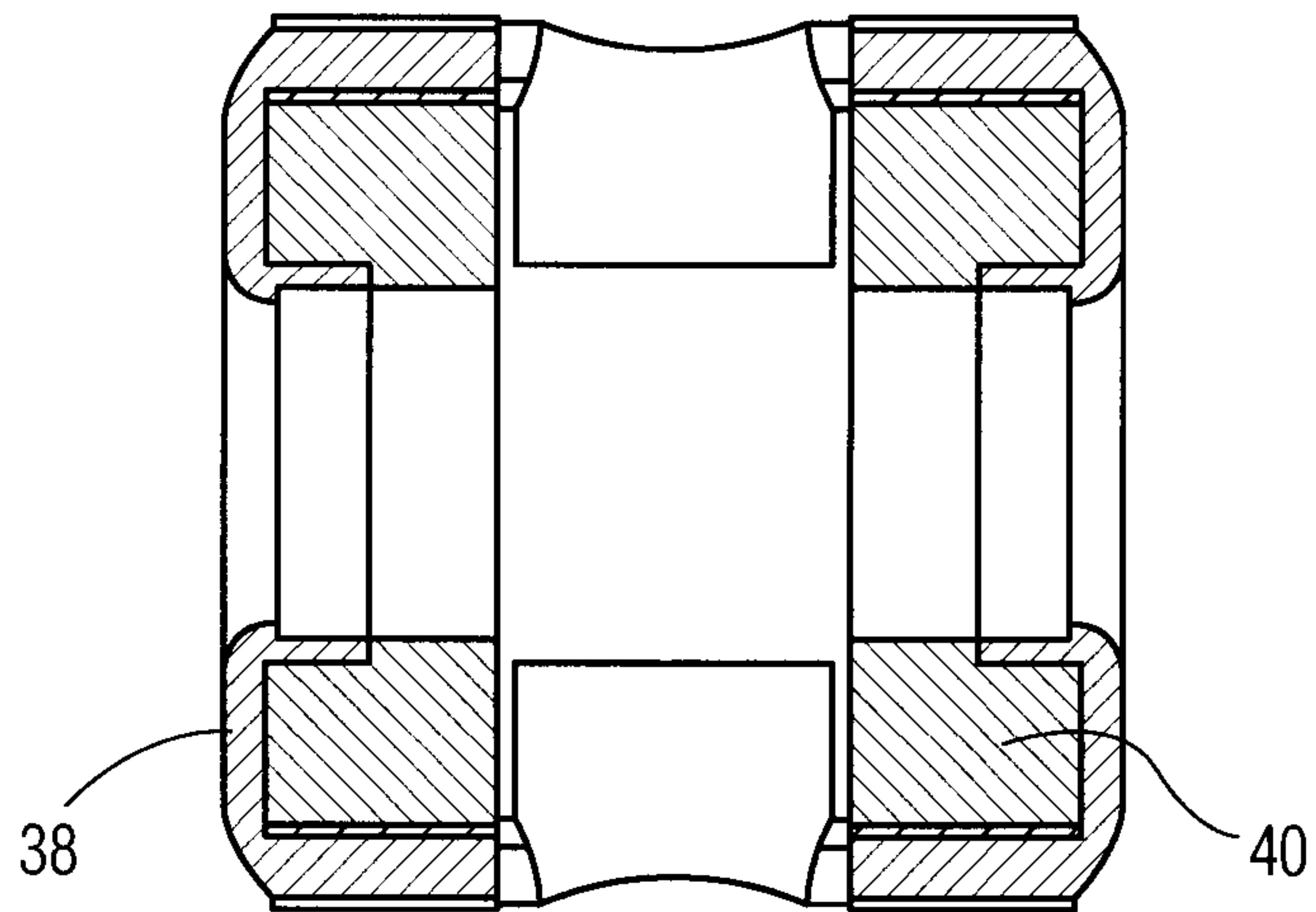

FIG. 8A

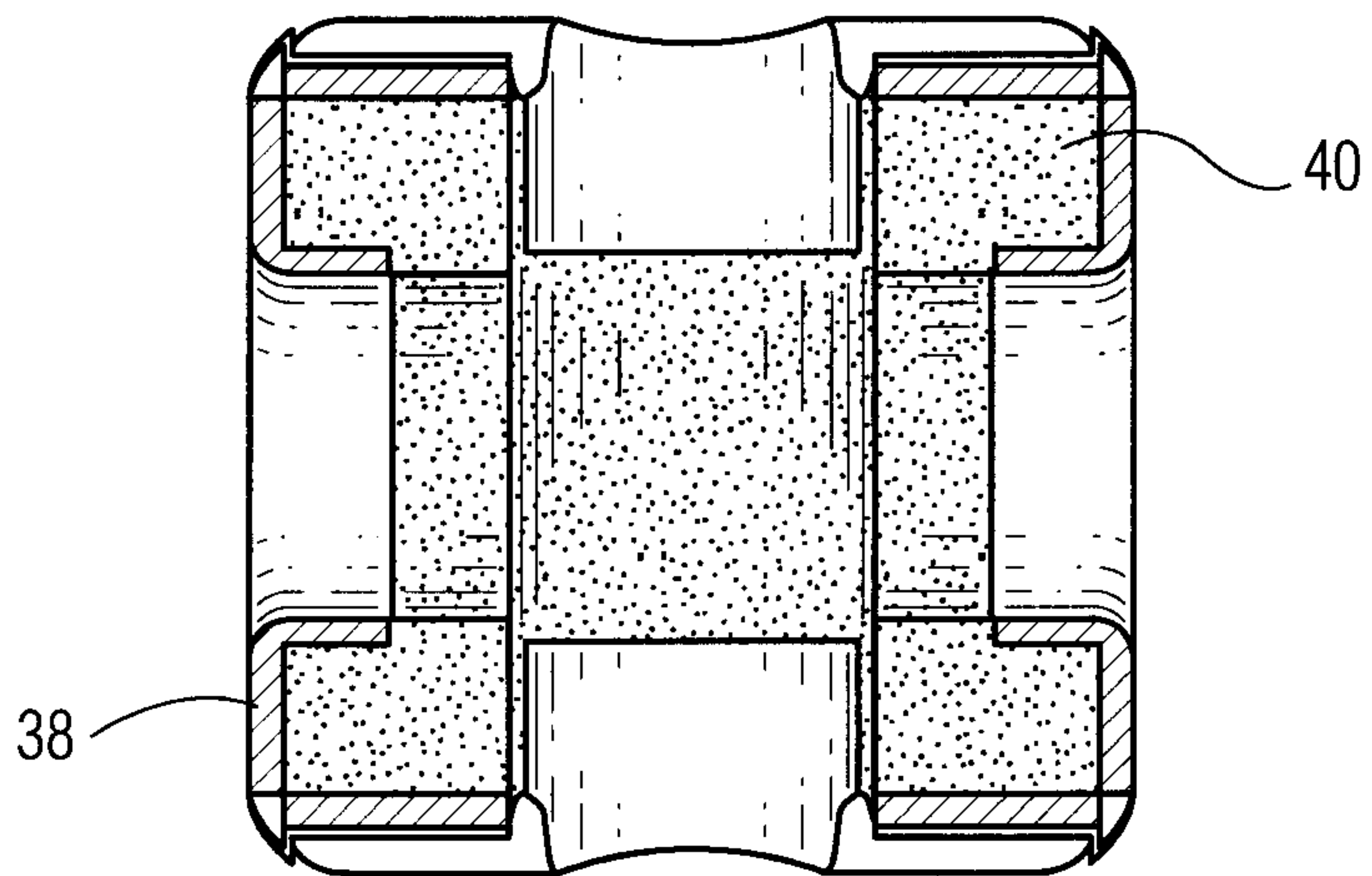

FIG. 8B

8/15

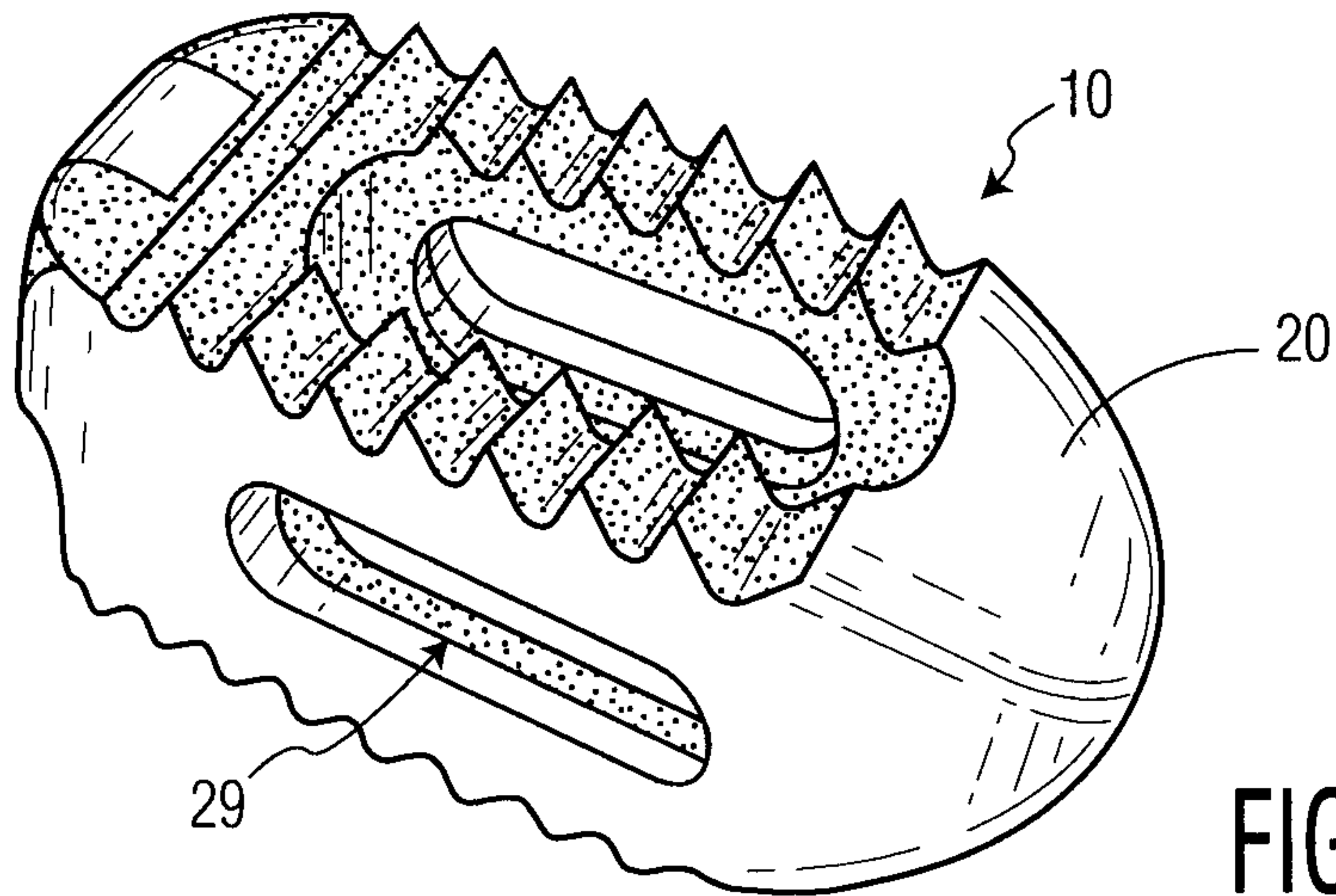

FIG. 9A

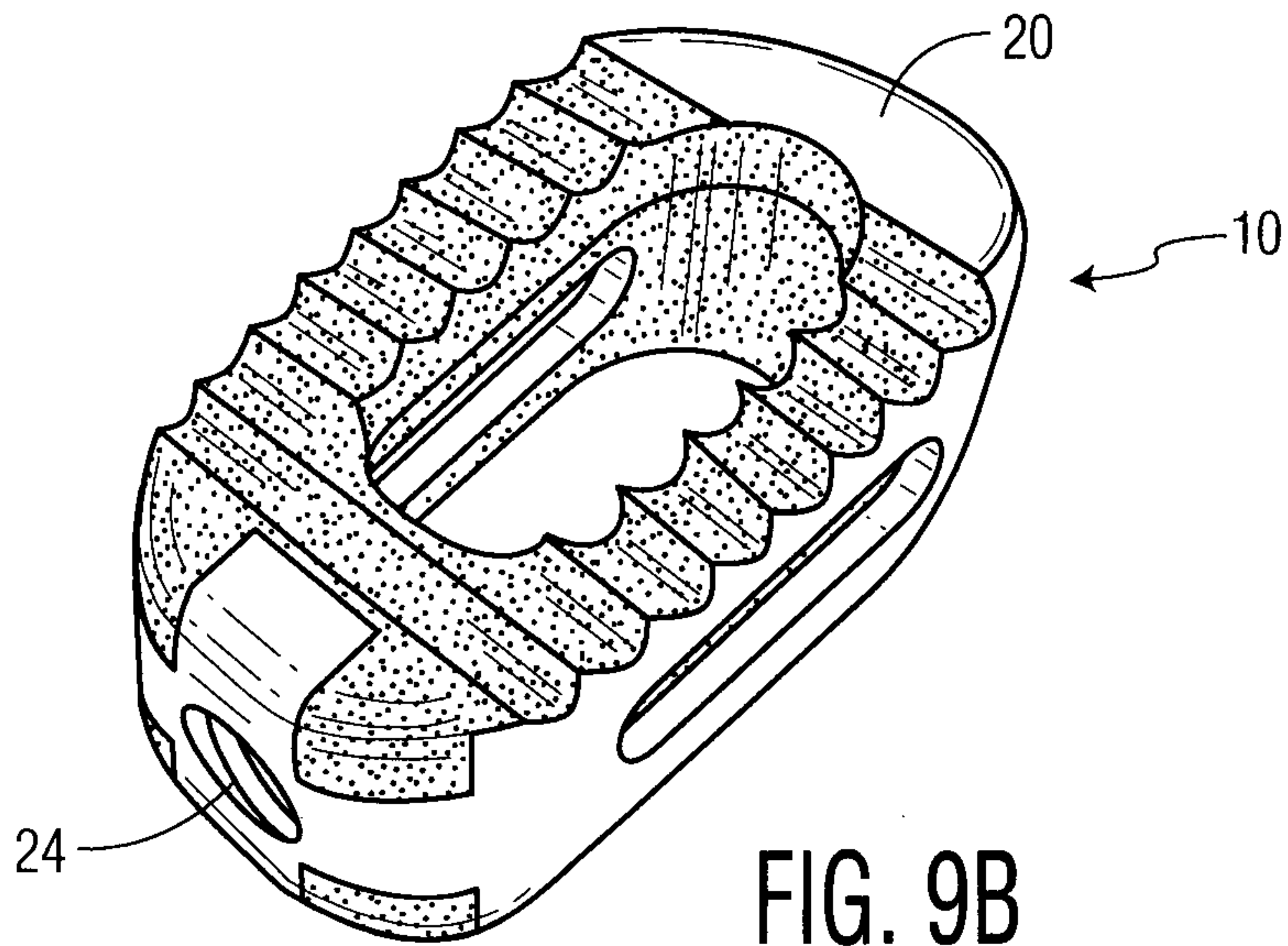

FIG. 9B

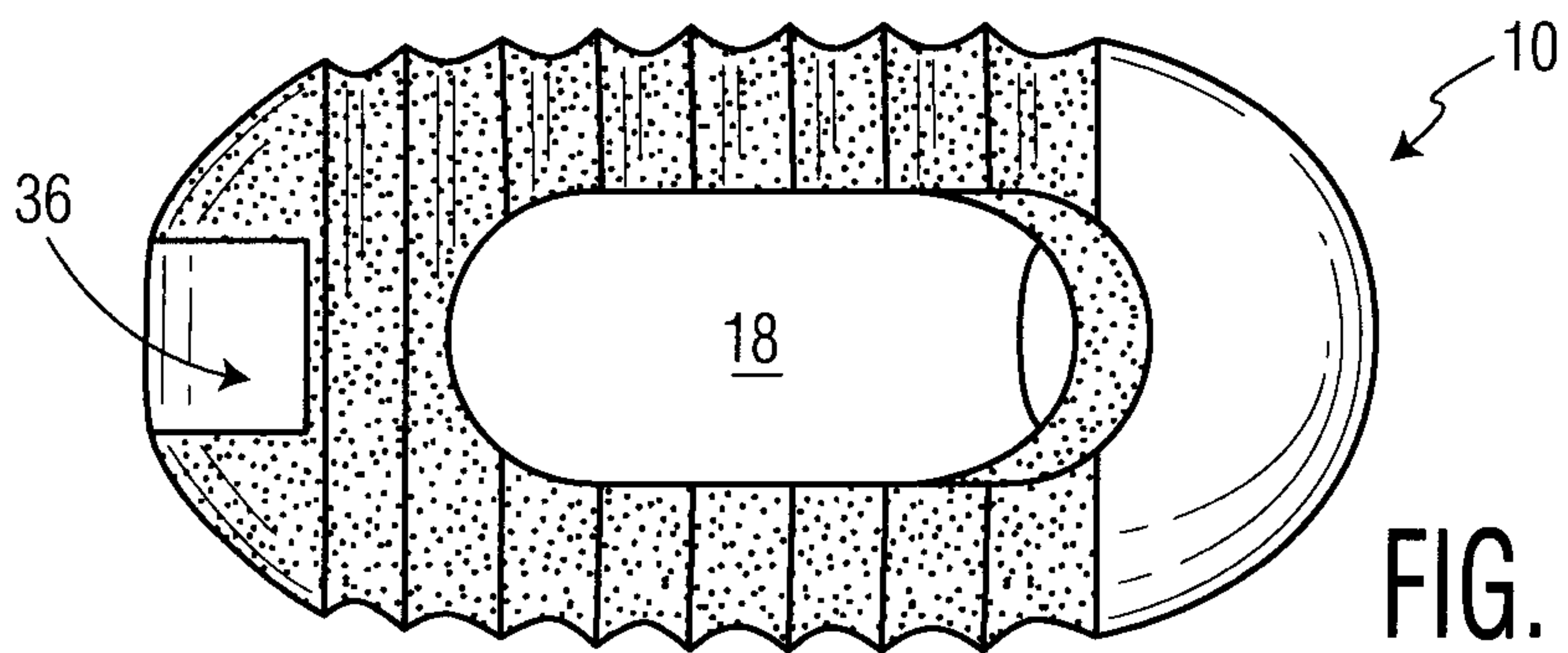

FIG. 9C

9/15

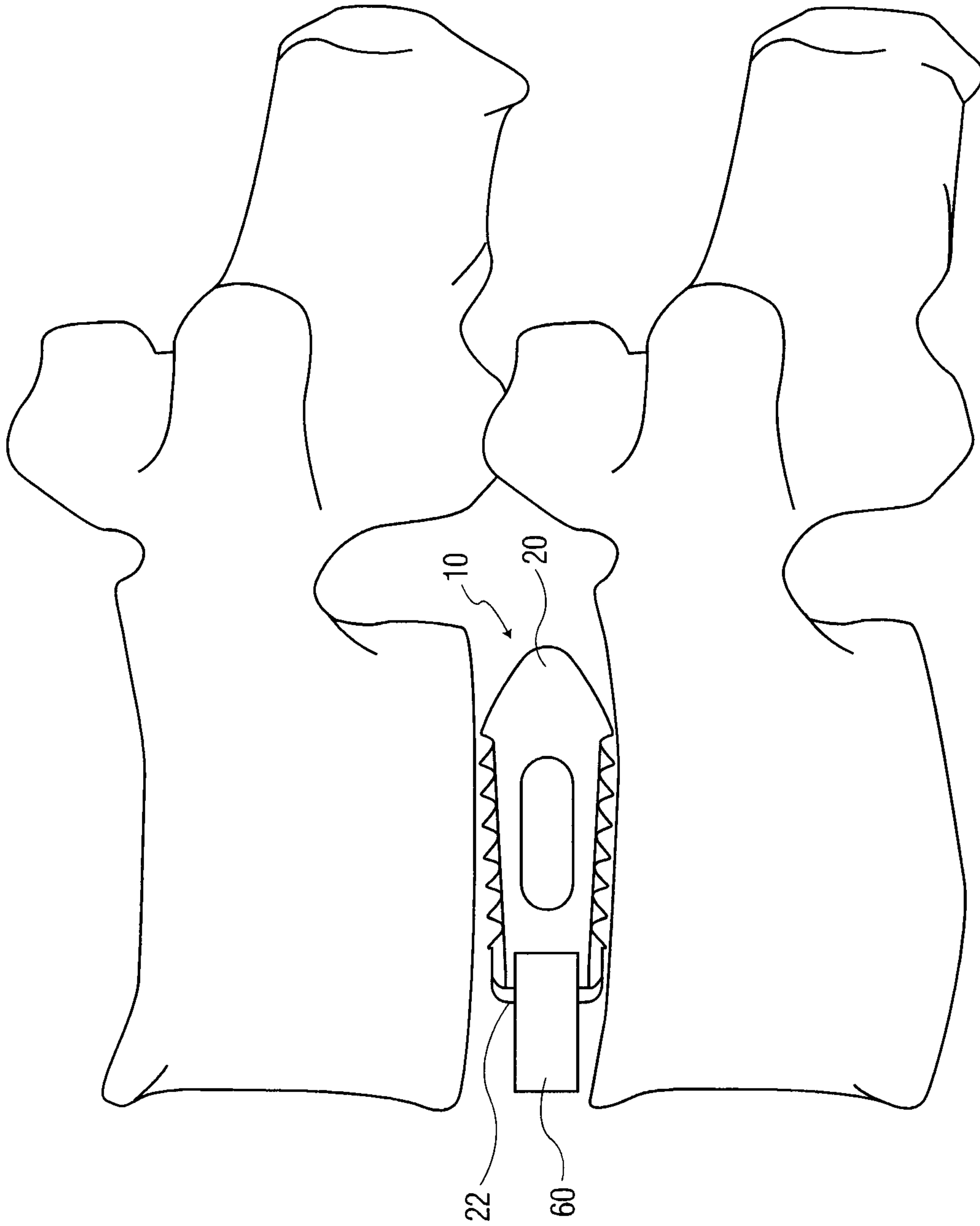
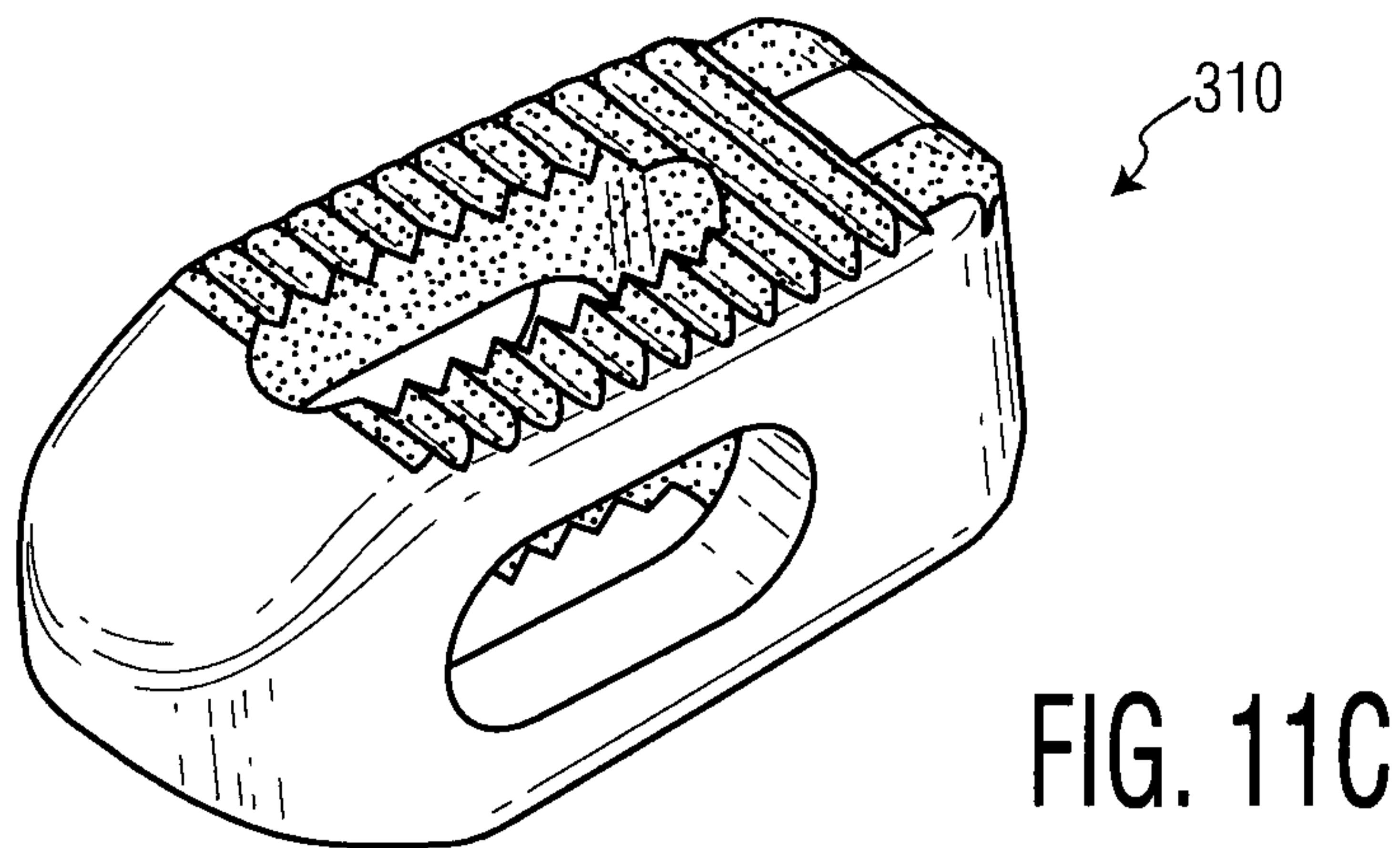
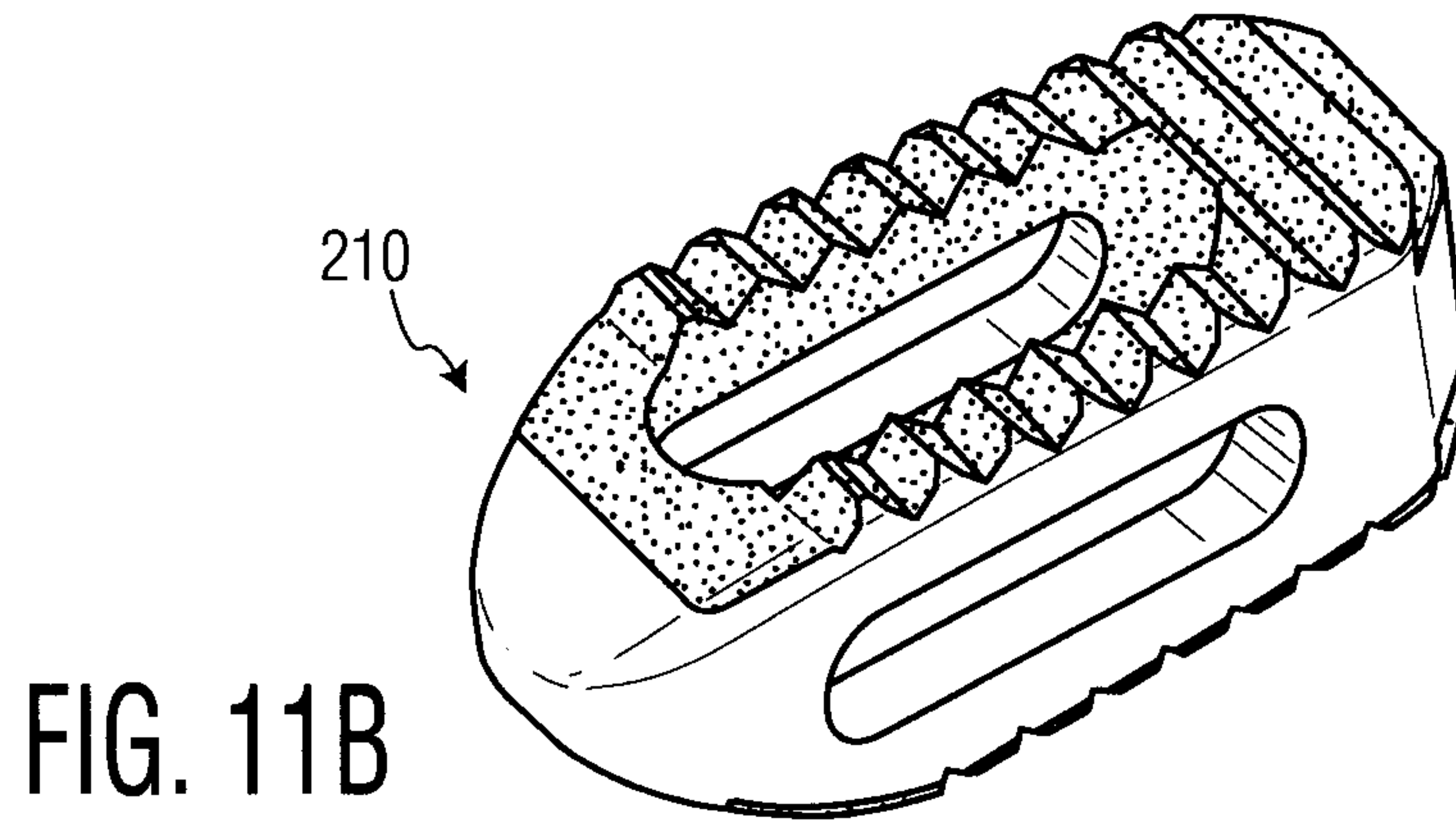
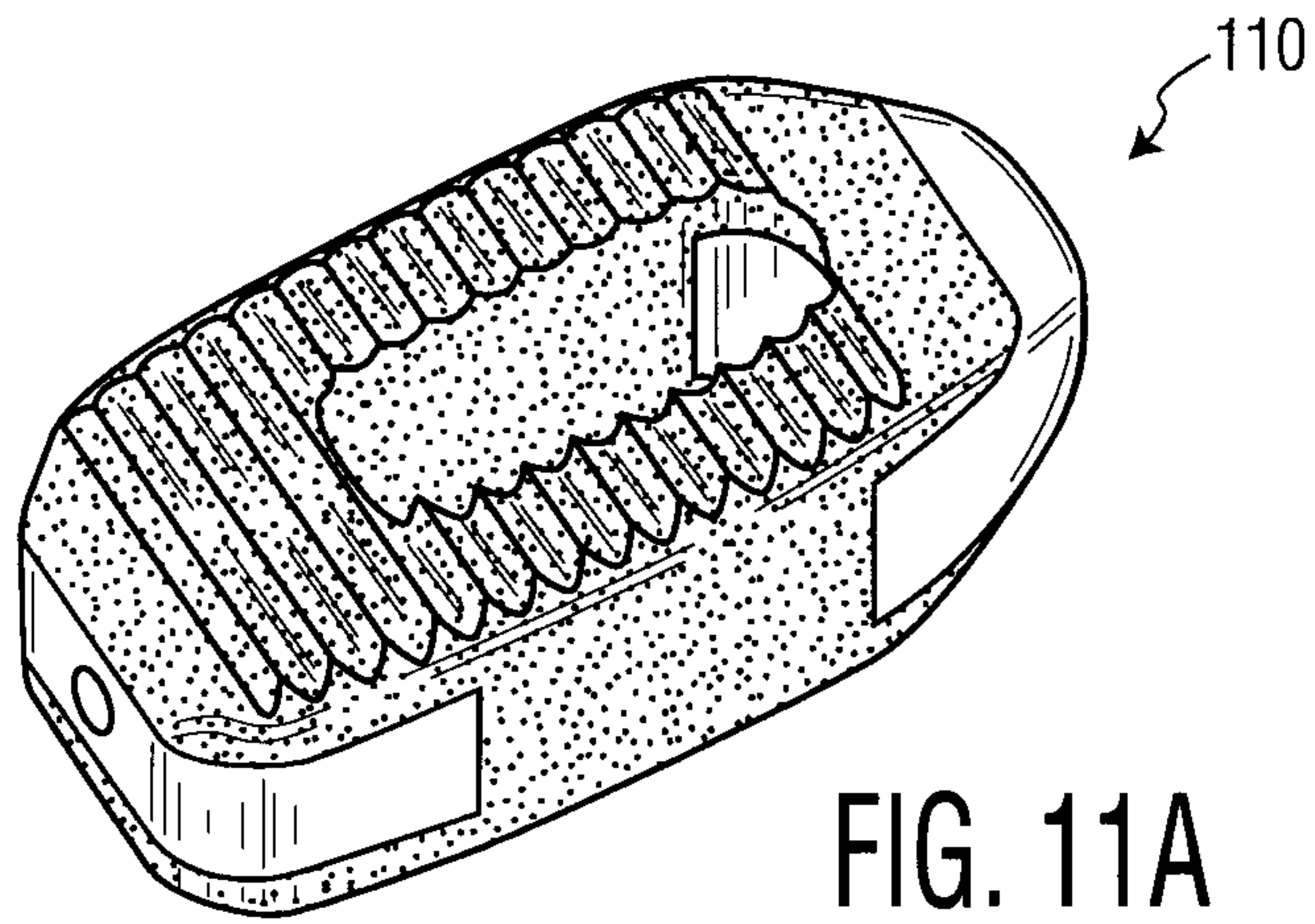
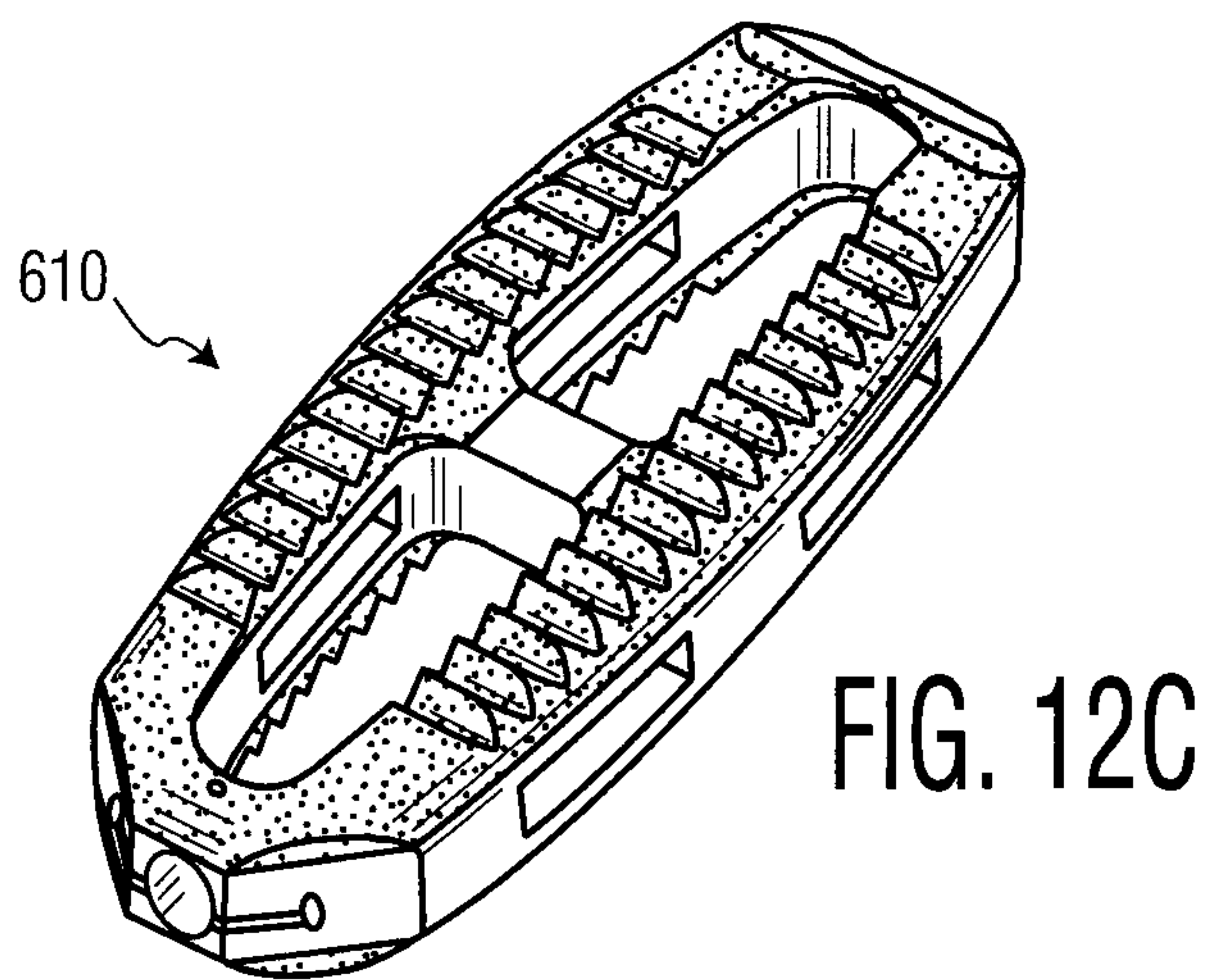
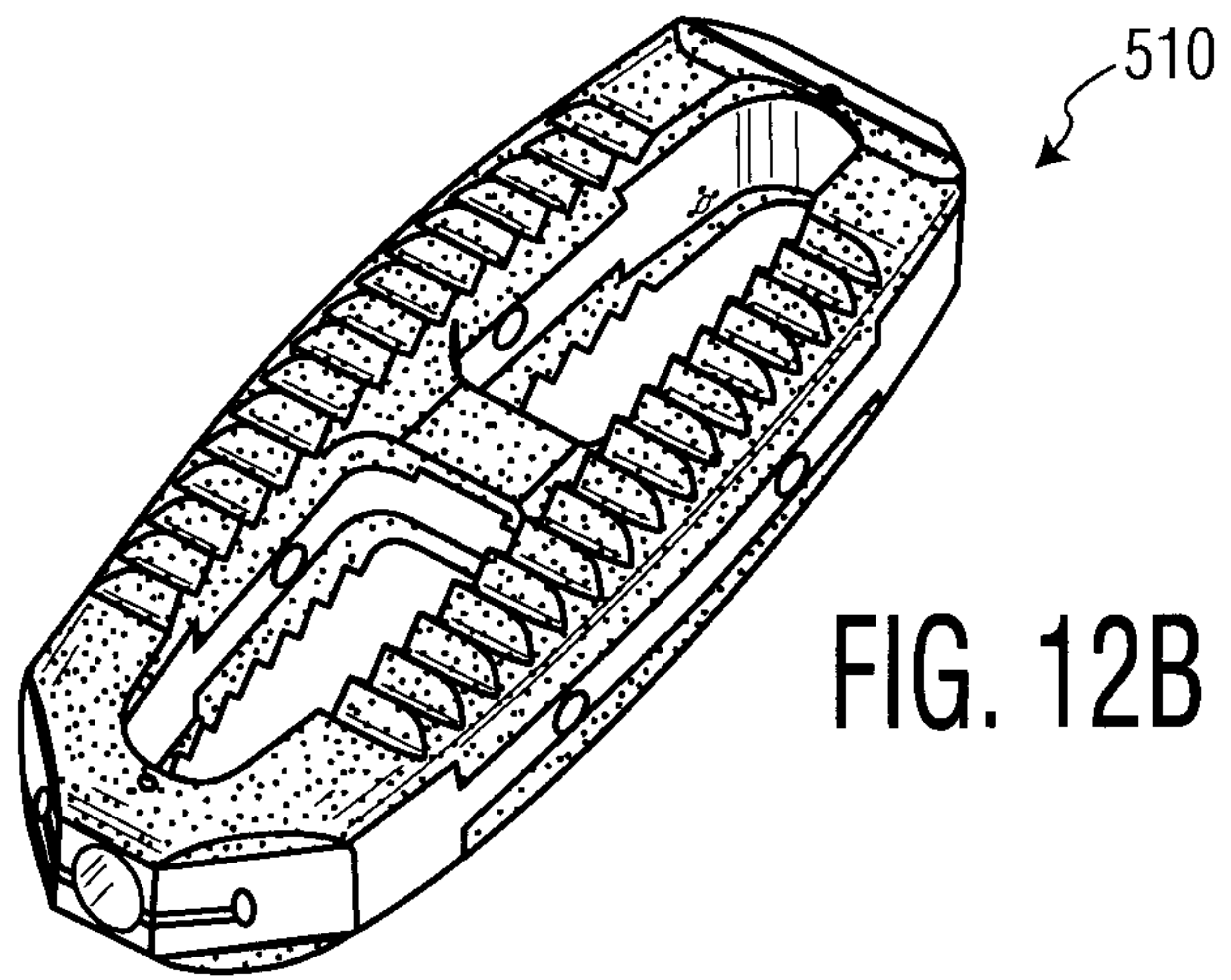
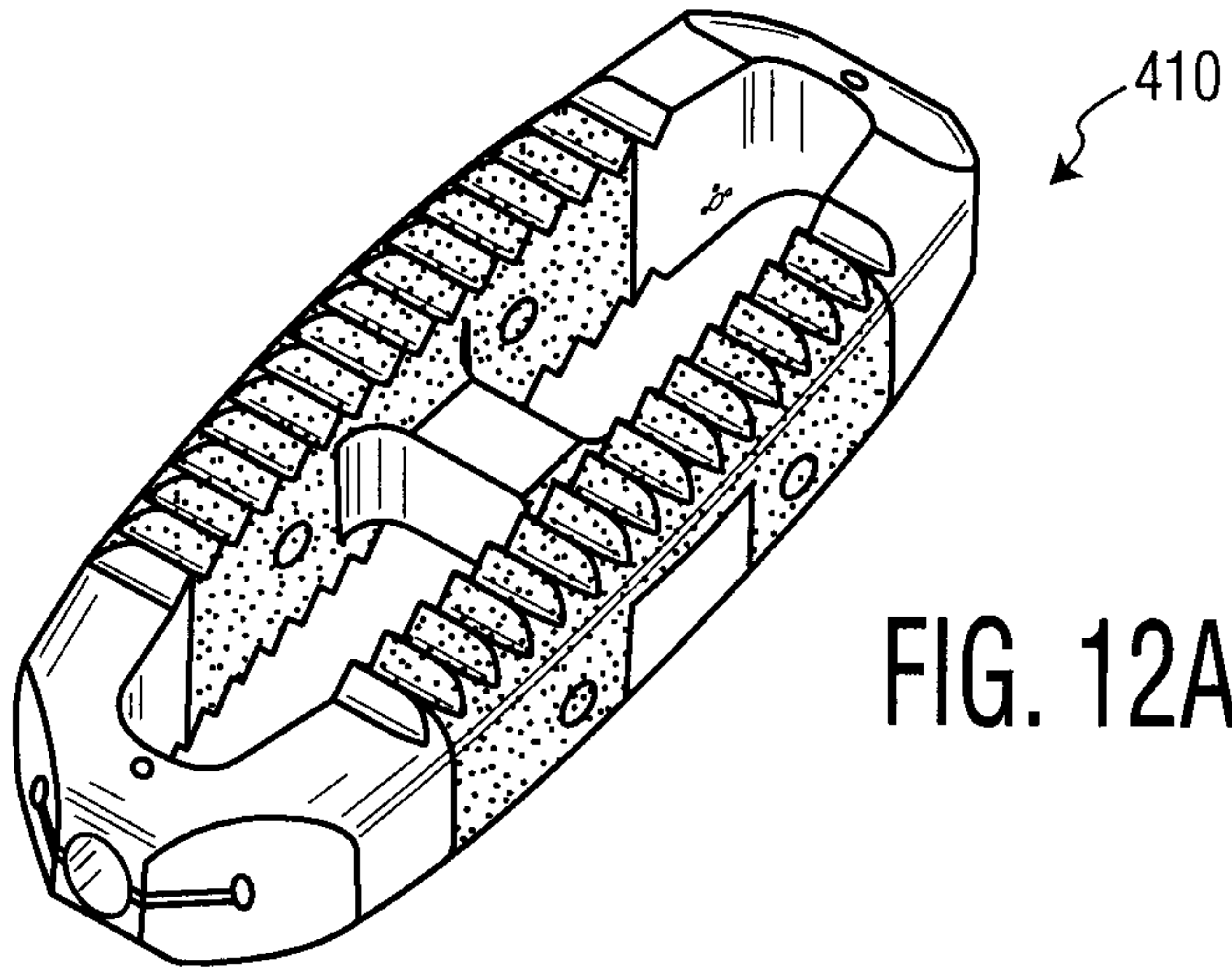

FIG. 10

10/15



11/15



12/15

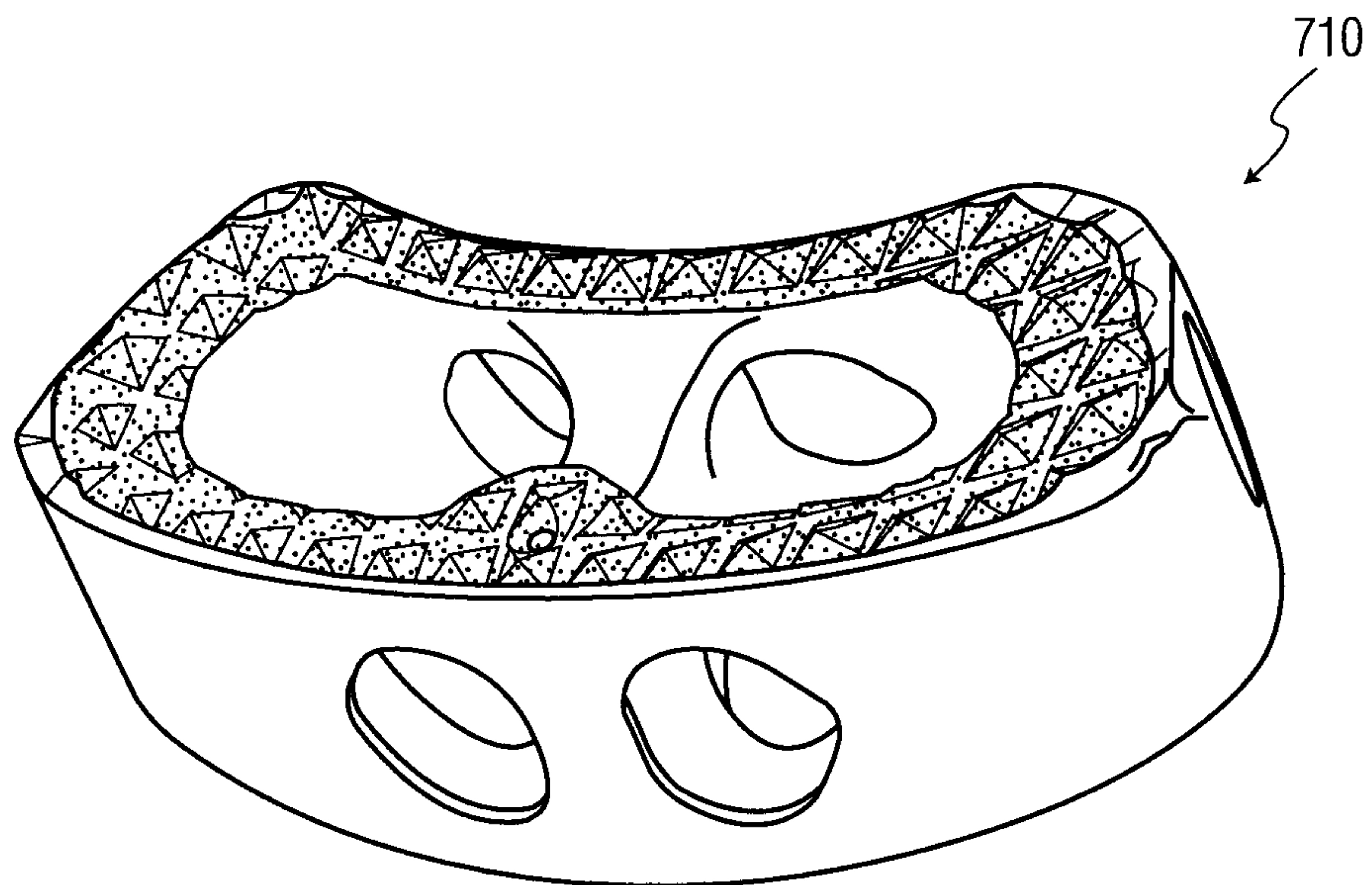

FIG. 13A

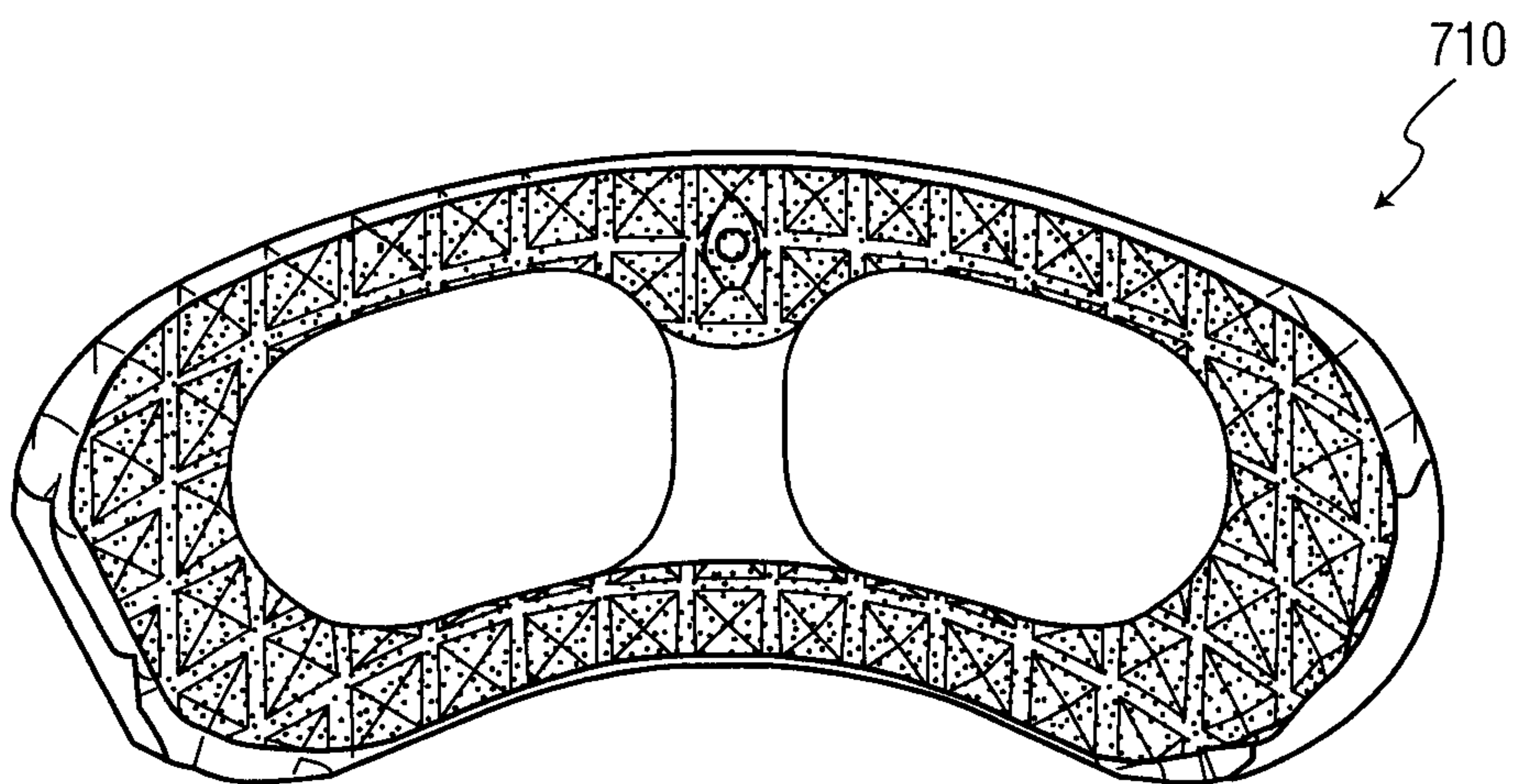

FIG. 13B

13/15

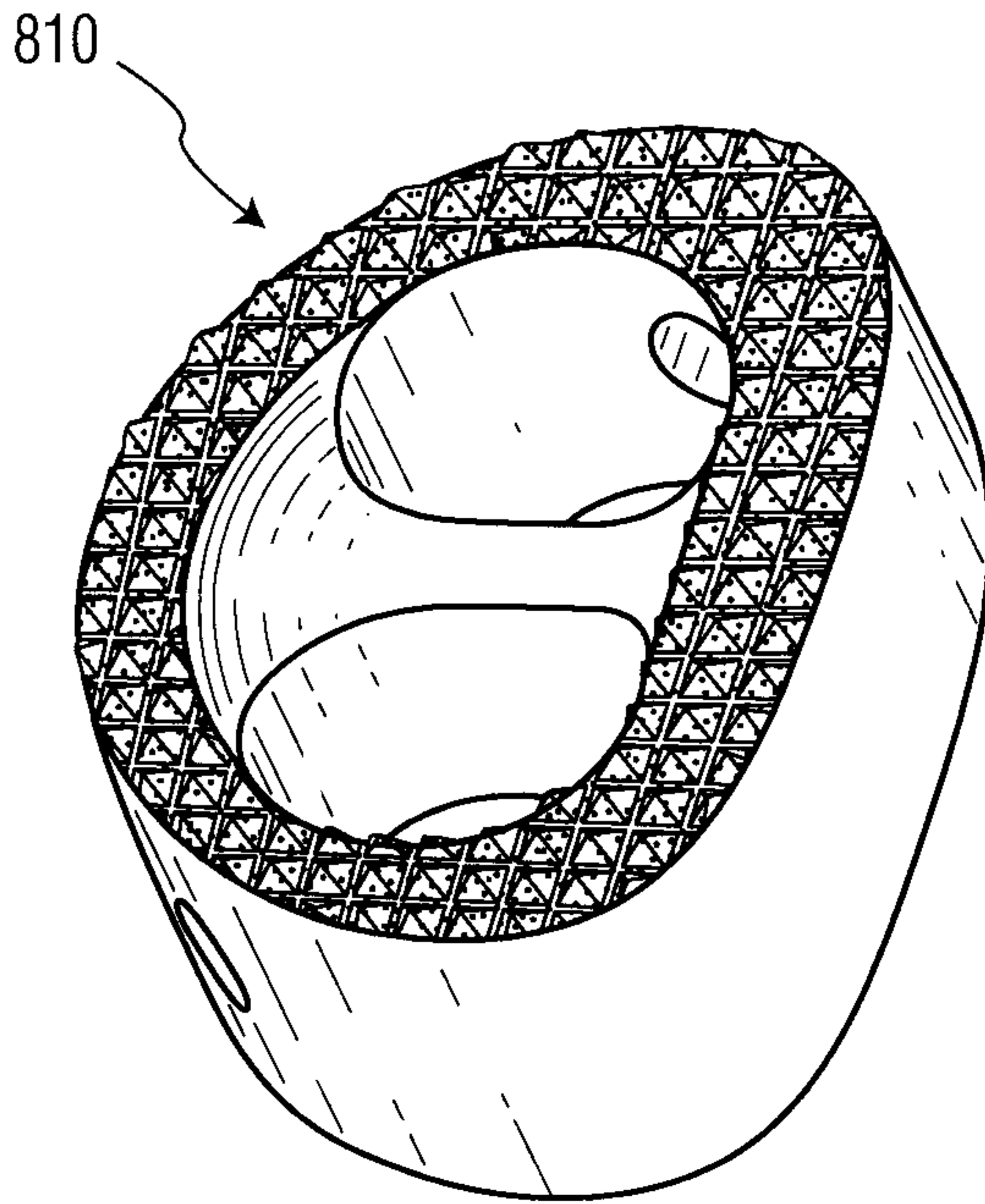

FIG. 14A

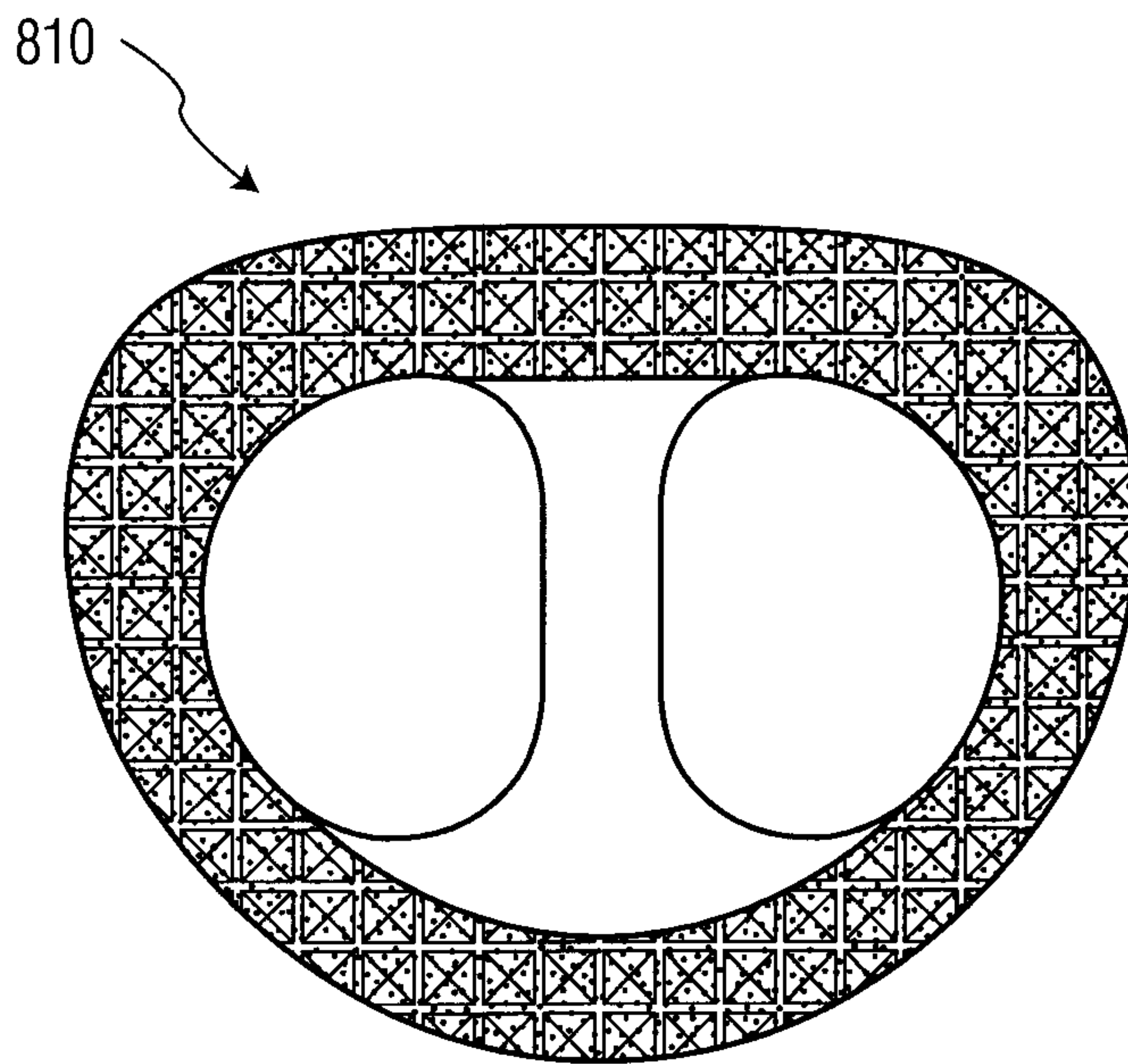

FIG. 14B

14/15

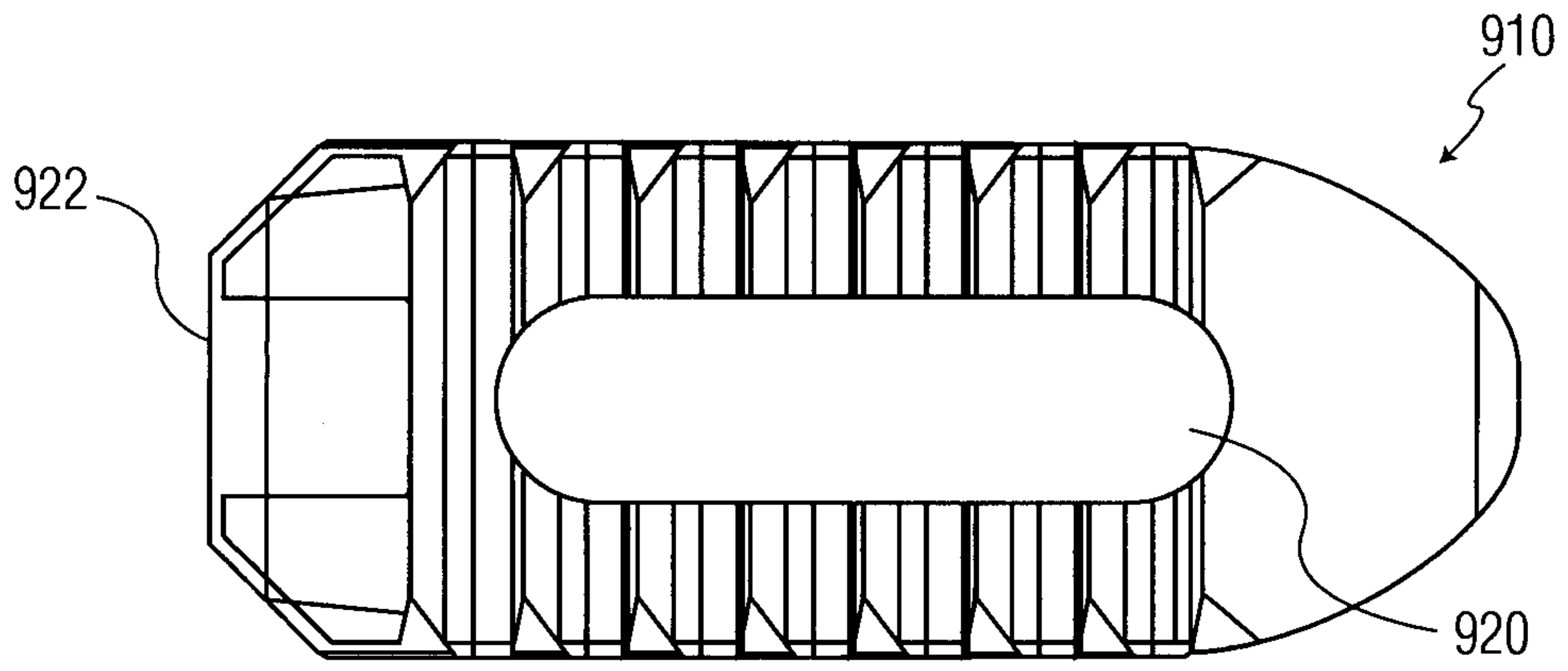

FIG. 15A

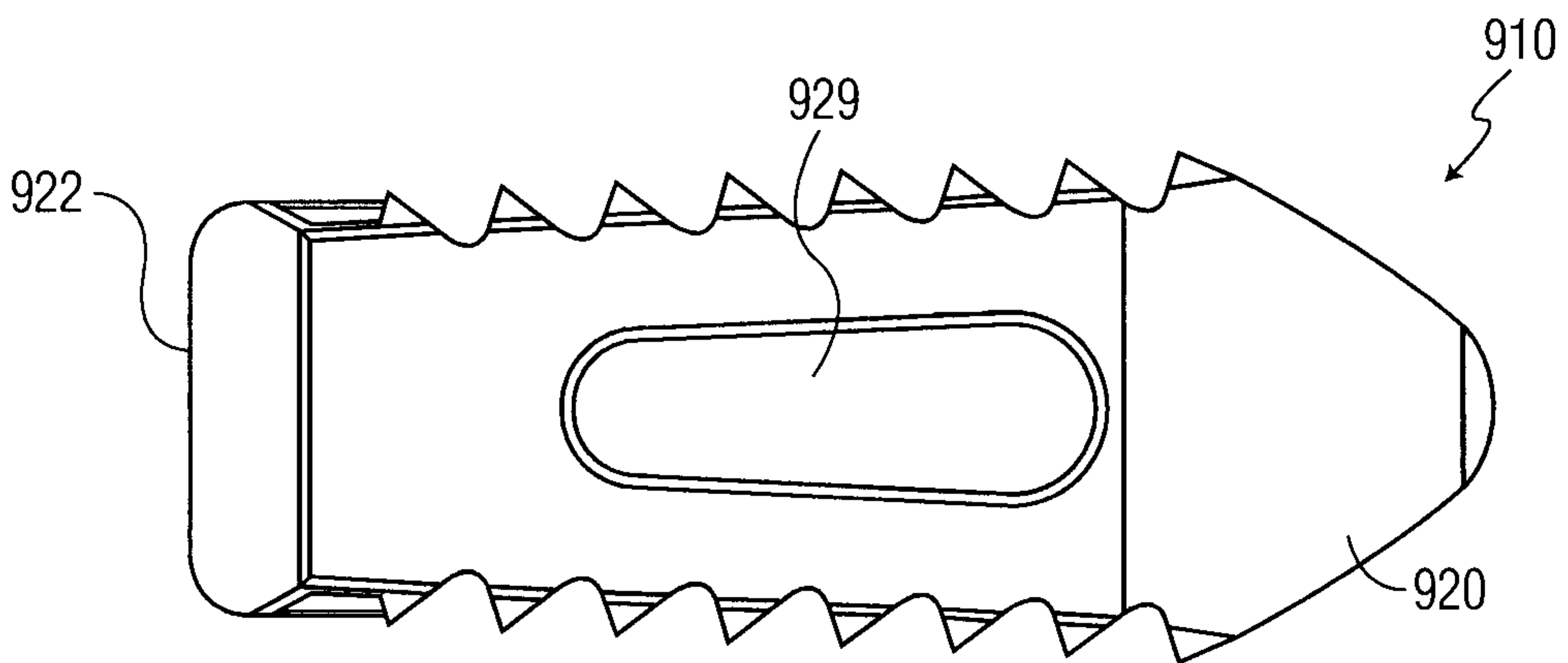

FIG. 15B

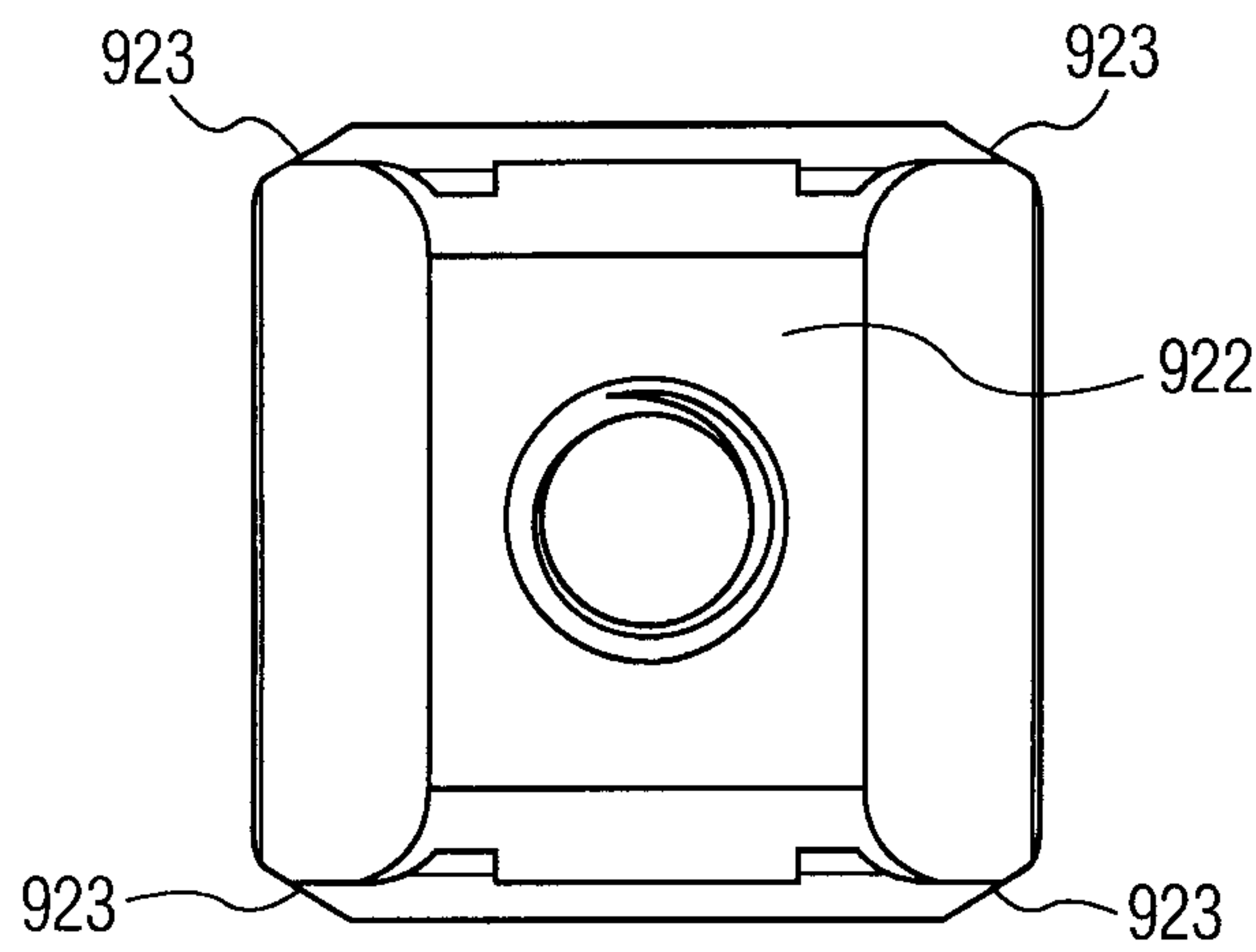

FIG. 15C

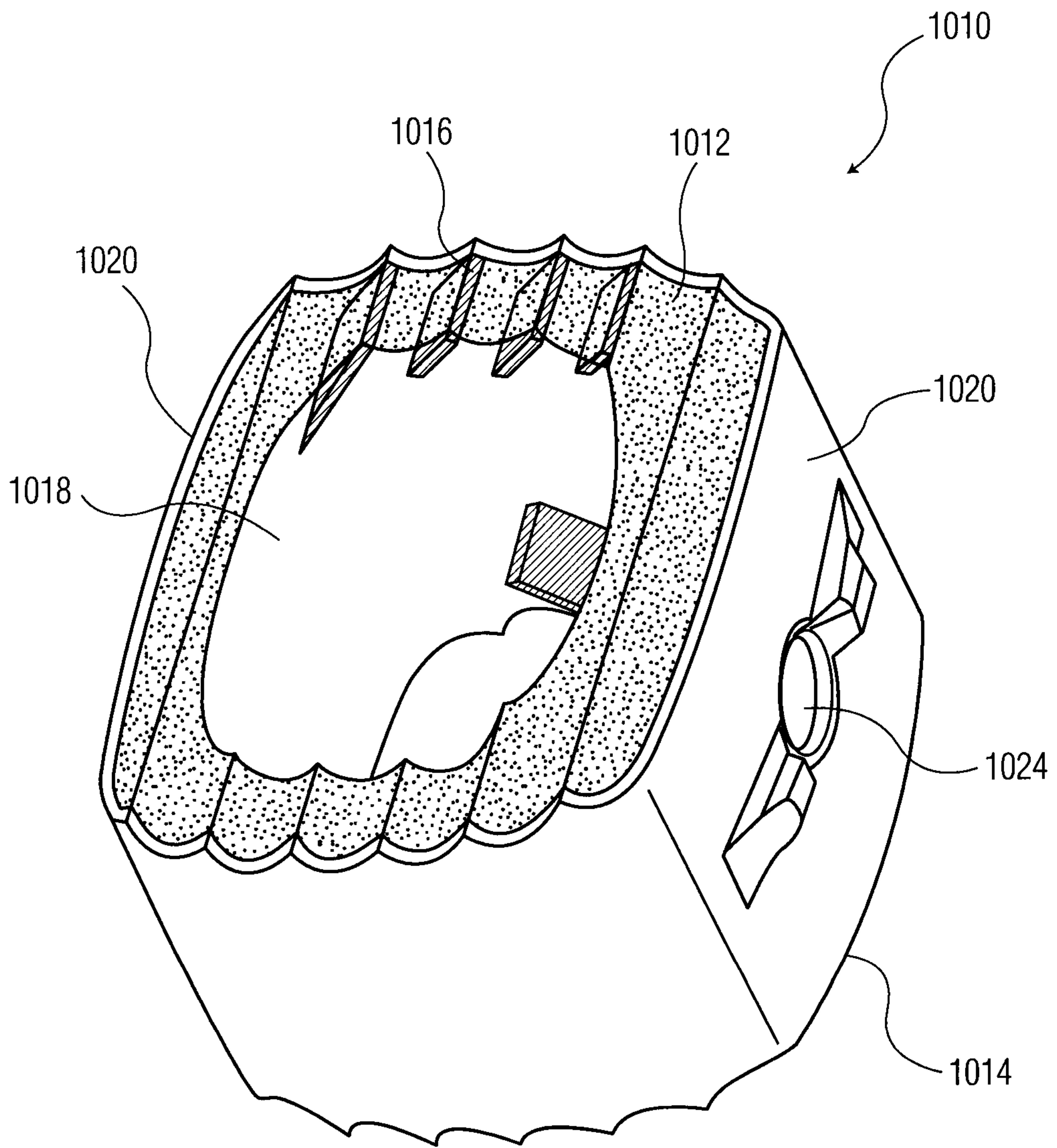

FIG. 16

