

(19)



(11)

**EP 1 623 948 B1**

(12)

**EUROPEAN PATENT SPECIFICATION**

(45) Date of publication and mention  
of the grant of the patent:  
**24.12.2008 Bulletin 2008/52**

(51) Int Cl.:  
**B66B 11/00<sup>(2006.01)</sup>**

(21) Application number: **05021783.5**

(22) Date of filing: **02.06.2000**

(54) **Positioning of a hoisting machine**

Stellung eines Hebezeuges

Placement d'une machinerie de levage

(84) Designated Contracting States:  
**DE FR GB NL**

(30) Priority: **03.06.1999 JP 15593199**  
**30.07.1999 JP 21675799**

(43) Date of publication of application:  
**08.02.2006 Bulletin 2006/06**

(62) Document number(s) of the earlier application(s) in  
accordance with Art. 76 EPC:  
**03026172.1 / 1 400 478**  
**00111059.2 / 1 057 771**

(73) Proprietor: **mitsubishi denki kabushiki**  
**KAISHA**  
**Chiyoda-ku**  
**Tokyo 100-8310 (JP)**

(72) Inventor: **Hashiguchi, Naoki**  
**Chiyoda-ku,**  
**Tokyo 100-8310 (JP)**

(74) Representative: **HOFFMANN EITLE**  
**Patent- und Rechtsanwälte**  
**Arabellastrasse 4**  
**81925 München (DE)**

(56) References cited:  
**EP-A- 0 710 618**                      **EP-A- 0 841 283**  
**WO-A-99/16694**                      **ES-A1- 2 161 183**

**EP 1 623 948 B1**

Note: Within nine months of the publication of the mention of the grant of the European patent in the European Patent Bulletin, any person may give notice to the European Patent Office of opposition to that patent, in accordance with the Implementing Regulations. Notice of opposition shall not be deemed to have been filed until the opposition fee has been paid. (Art. 99(1) European Patent Convention).

## Description

[Field of the Invention]

**[0001]** The present invention relates to an elevator system wherein a hoisting machine that drives a main rope to which a car and a counterweight are connected is installed in a hoistway.

[Description of Prior Art]

**[0002]** Fig. 35 and Fig. 36 show a conventional elevator system disclosed in Japanese Unexamined Patent Publication No. 10-139321 and also shown in EP-A-0841283. Fig. 35 is a perspective view conceptually illustrating the elevator system, and Fig. 36 is a cross top plan view of an essential section of the elevator system of Fig. 35. In the drawings, reference numeral 1 denotes a hoistway, reference numeral 2 denotes a car that ascends and descends along a predetermined path of the hoistway 1, reference numeral 3 denotes a counterweight disposed on one side in a horizontal surface in the hoistway 1, and reference numeral 4 denotes a hoisting machine that is disposed on a bottom surface of a ceiling by a support member 5 provided at an upper portion of the hoistway 1 and on which a driving sheave 6 pivotally held via a vertical axis is provided.

**[0003]** Reference numeral 7 denotes a first car pulley provided on one side of a bottom portion of the car 2, reference numeral 8 denotes a second car pulley provided on the other side of the bottom portion of the car 2, reference numeral 9 denotes a counterweight pulley provided above the counterweight 3, reference numeral 10 denotes a car inverting pulley that is pivotally attached at an upper portion of the hoistway 1 via a horizontal axis and disposed at a position corresponding to the second car pulley 8, and reference numeral 11 denotes a counterweight inverting pulley that is pivotally attached to an upper portion of the hoistway 1 via the horizontal axis and disposed at a position corresponding to the counterweight pulley 9. The car inverting pulley 10 and the counterweight inverting pulley 11 both partly overlap the car 2 in a vertical projection.

**[0004]** Reference numeral 12 denotes a main rope which has one end thereof connected to the upper portion of the hoistway 1 by a first rope retaining fixture 13 disposed on the ceiling of the hoistway 1, corresponding to the first car pulley 7, and extends downward, and is wound on the first car pulley 7 and the second car pulley 8, then extends upward to be wound on the car inverting pulley 10 to be tightly stretched in a horizontal direction. The main rope 12 is then wound on the driving sheave 6 and also on the counterweight inverting pulley 11, and extends downward to be wound on the counterweight pulley 9, then extends upward so that the other end thereof is connected to the upper portion of the hoistway 1 by a second rope retaining fixture 14 disposed on the ceiling of the hoistway 1, corresponding to the counterweight

pulley 9.

**[0005]** The conventional elevator system is constructed as set forth above. The hoisting machine 4 is urged, and the driving sheave 6 rotates, causing the car 2 and the counterweight 3 to vertically move in opposite directions from each other via the main rope 12. The hoisting machine 4 is disposed at the upper portion in the hoistway 1 to obviate the need for a machine room independently provided, thereby saving a space for installing the elevator system in a building.

[Problem to be solved by the Invention]

**[0006]** In the conventional elevator system described above, the car inverting pulley 10 and the counterweight inverting pulley 11 are disposed at the upper portion of the hoistway 1 such that they overlap the car 2 in a top plan view as shown in Fig. 36. This has been posing a problem in that a space for accommodating the inverting pulleys 10 and 11 is required to be provided between the car 2 and the ceiling of the hoistway when the car 2 reaches a highest level.

**[0007]** Furthermore, a positional relationship between the car inverting pulley 10 and the counterweight inverting pulley 11 decides a winding angle  $\theta$  of the main rope 12 wound on the driving sheave 6. The winding angle  $\theta$  influences a traction capability of the driving sheave 6 which is expressed as shown below.

$$\text{Traction capability} = e^{k\theta}$$

**[0008]** Hence, in order to increase the winding angle  $\theta$  to secure the traction capability, it is necessary to dispose the car inverting pulley 10 and the counterweight inverting pulley 11 as closely as possible. This leads to a lower degree of freedom in disposing units in the hoistway. If priority is given to the degree of freedom of the units in the hoistway, then it is not always possible to position the car inverting pulley 10 and the counterweight inverting pulley 11 closely, possibly leading to a failure to secure an adequate traction capability.

**[0009]** The present invention has been made with a view toward solving such problems, and it is an object thereof to provide an elevator system that includes a hoisting machine in a hoistway, and the hoistway can be installed at a height suited to a height of a highest level in a building.

**[0010]** It is another object of the present invention to provide an elevator system wherein a winding angle  $\theta$  is larger to secure a traction capability.

**[0011]** It is yet another object of the present invention to provide an elevator capable of reducing a fleet angle, prolonging a service life of a main rope, etc. The fleet angle is a value indicating a misalignment between a sheave groove of a driving sheave and a sheave groove of a counterweight inverting pulley through which the main rope passes. The fleet angle will be discussed in more detail hereinafter.

[Means to Solve the Problem]

**[0012]** According to one aspect of the present invention, there is provided an elevator system according to the subject-matter of claim 1.

[Brief Description of the Drawings]

**[0013]**

[Fig. 1]

Fig. 1 is a conceptual front view showing a first embodiment (not part of the invention).

[Fig. 2]

Fig. 2 is a side view of the embodiment shown in Fig. 1.

[Fig. 3]

Fig. 3 is a cross top plan view of an essential section of the embodiment shown in Fig. 1.

[Fig. 4]

Fig. 4 is a perspective view corresponding to Fig. 3.

[Fig. 5]

Fig. 5 is a conceptual front view showing a second embodiment (not part of the invention).

[Fig. 6]

Fig. 6 is a side view of the embodiment shown in Fig. 5.

[Fig. 7]

Fig. 7 is a cross top plan view of an essential section of the embodiment shown in Fig. 5.

[Fig. 8]

Fig. 8 is a perspective view corresponding to Fig. 5.

[Fig. 9]

Fig. 9 is a conceptual front view showing a third embodiment (not part of the invention).

[Fig. 10]

Fig. 10 is a cross top plan view of an essential section of the embodiment shown in Fig. 9.

[Fig. 11]

Fig. 11 is a perspective view corresponding to Fig. 10.

[Fig. 12]

Fig. 12 is a conceptual front view showing a fourth embodiment (not part of the invention).

[Fig. 13]

Fig. 13 is a cross top plan view of an essential section of the embodiment shown in Fig. 12.

[Fig. 14]

Fig. 14 is a perspective view corresponding to Fig. 13.

[Fig. 15]

Fig. 15 is a conceptual front view showing a fifth embodiment (not part of the invention).

[Fig. 16]

Fig. 16 is a cross top plan view of an essential section of the embodiment shown in Fig. 15.

[Fig. 17]

Fig. 17 is a perspective view corresponding to Fig.

16.

[Fig. 18]

Fig. 18 is a conceptual front view showing a sixth embodiment of the present invention.

[Fig. 19]

Fig. 19 is a cross top plan view of an essential section of the embodiment shown in Fig. 18.

[Fig. 20]

Fig. 20 is a diagram illustrating a relationship between tensions of a main rope and axial forces.

[Fig. 21]

Fig. 21 is a conceptual front view showing a seventh embodiment (not part of the invention).

[Fig. 22]

Fig. 22 is a cross top plan view of an essential section of the embodiment shown in Fig. 21.

[Fig. 23]

Fig. 23 is a front view showing an eighth embodiment (not part of the invention).

[Fig. 24]

Fig. 24 is a cross top plan view of an essential section of the embodiment shown in Fig. 23.

[Fig. 25]

Fig. 25 is a diagram showing a positional relationship between a driving sheave 6 and a counterweight inverting pulley 11 in a conventional elevator system.

[Fig. 26]

Fig. 26 is a diagram illustrating forces acting on a main rope 12 and a side surface of a sheave groove.

[Fig. 27]

Fig. 27 is a diagram showing a positional relationship between a driving sheave 6 and a counterweight inverting pulley 11 in the present embodiment.

[Fig. 28]

Fig. 28 is a diagram showing a relationship between a tilt angle  $\alpha$  of a hoisting machine 18 and a moving distance  $a_2$  of the main rope 12.

[Fig. 29]

Fig. 29 is a front view showing a ninth embodiment (not part of the invention).

[Fig. 30]

Fig. 30 is a cross top plan view of an essential section of the embodiment shown in Fig. 29.

[Fig. 31]

Fig. 31 is a cross top plan view of an essential section of a tenth embodiment in accordance with the present invention.

[Fig. 32]

Fig. 32 is a diagram showing forces in a horizontal direction observed when a hoisting machine 18 and inverting pulleys 10 and 11 are mounted on an integral-type mounting base 25.

[Fig. 33]

Fig. 33 is a diagram showing forces in a vertical direction observed when the hoisting machine 18 and the inverting pulleys 10 and 11 are mounted on the integral-type mounting base 25.

[Fig. 34]

Fig. 34 is a diagram showing a space in a direction of height for installing the mounting base 25, the hoisting machine 18, and the inverting pulleys 10 and 11 when the driving sheave 6 is provided on a lower side of the hoisting machine 18.

[Fig. 35]

Fig. 35 is a conceptual perspective view showing a conventional elevator system.

[Fig. 36]

Fig. 36 is a cross top plan view showing an essential section of the elevator system shown in Fig. 35.

#### [Embodiments]

##### First Embodiment (not part of the invention)

**[0014]** Fig. 1 through Fig. 4 show an embodiment. Fig. 1 is a front view conceptually showing the embodiment, Fig. 2 is a side view of the embodiment shown in Fig. 1, Fig. 3 is a cross top plan view (a vertical projection) of an essential section of the embodiment shown in Fig. 1, and Fig. 4 is a perspective view corresponding to Fig. 3. In the drawings, reference numeral 1 denotes a hoistway, and reference numeral 2 denotes a car that ascends and descends along a predetermined path of the hoistway 1 and is provided with an entrance 15 and a crosshead 16. A top surface of a ceiling of the car extends down from a top surface of the crosshead 16 to form a withdrawal surface 17.

**[0015]** Reference numeral 3 denotes a counterweight disposed on one side in a horizontal surface in the hoistway 1. Reference numeral 18 denotes a hoisting machine that is disposed at an upper corresponding position of a side surface of the car 2 away from the entrance 15, i.e., at a position corresponding to the withdrawal surface 17 of the car 2, and attached to a bottom surface of the ceiling of the hoistway 1, the hoisting machine being provided with a driving sheave 6 pivotally held via a vertical axis. The driving sheave 6 of the hoisting machine 18 is positioned near the ceiling of the hoistway 1, and faces against the ceiling of the hoistway 1. The driving sheave 6 in this embodiment has a diameter that is smaller than an outside diameter of the hoisting machine 18. This arrangement permits effective use of a space formed by the ceiling and side walls of the hoistway 1.

**[0016]** The hoisting machine 18 is inclined with respect to a horizontal direction (or disposed aslant as observed sideways). More specifically, a part of the hoisting machine 18 overlaps the car 2 in a vertical projection, and the rest thereof is positioned between the car 2 and the wall of the hoistway 1, the hoisting machine 18 being inclined so that the part overlapping the car 2 is closer to the ceiling of the hoistway 1 than the rest is. Furthermore, the hoisting machine 18 is installed so that it is positioned closely to the side wall of the hoistway 1 as much as possible.

**[0017]** Reference numeral 7 denotes a first car pulley provided at one side of a bottom portion of the car 2, and

reference numeral 8 denotes a second car pulley provided at the other side of the bottom portion of the car 2.

**[0018]** Reference numeral 9 denotes a counterweight pulley provided above the counterweight 3. Reference numeral 10 denotes a car inverting pulley that is disposed in a gap between an inner wall of the hoistway 1 and the car 2 in a vertical projection, and pivotally attached to an upper portion of the hoistway 1 via a horizontal axis, being disposed at a position matching the second car pulley 8.

**[0019]** Reference numeral 11 denotes a counterweight inverting pulley that is disposed in a gap between the inner wall of the hoistway 1 and the car 2 in a vertical projection, and pivotally attached to the upper portion of the hoistway 1 via the horizontal axis, being disposed at a position matching the counterweight pulley 9. The car inverting pulley 10 and the counterweight inverting pulley 11 are disposed in the same gap between the inner wall of the hoistway 1 and the car 2 as that wherein the car inverting pulley 10 is disposed. This arrangement is effective for reducing a cross-sectional area of the hoistway 1.

**[0020]** In this embodiment, the hoisting machine 18 and inverting pulleys 10 and 11 are disposed at the upper portion of the gap wherein the counterweight 3 is disposed, in particular, in the gap between the car 2 and the side walls of the hoistway 1, thereby effectively using the gap required for installing the counterweight 3. Moreover, the hoisting machine 18 is disposed closer to a corner of the hoistway 1 as can be seen from Fig. 3 so as to minimize a possibility of its interference with the car 2.

**[0021]** Furthermore, a rotation surface of the car inverting pulley 10 and a rotation surface of the counterweight inverting pulley 11 are disposed aslant with respect to a side surface of the car 2 and a wall surface of the hoistway 1 so that they intersect with each other.

**[0022]** Reference numeral 19 denotes buffers that are provided on the bottom surface of the hoistway 1 and disposed for the car 2 and the counterweight 3, respectively.

**[0023]** Reference numeral 12 denotes a main rope which has one end thereof connected at the upper portion of the hoistway 1 by a first rope retaining fixture 13 disposed at an upper portion of the hoistway 1, corresponding to the first car pulley 7, and descends. The main rope has the one end thereof wound on the first car pulley 7 and the second car pulley 8 to ascend, and it is wound on the car inverting pulley 10 to be tightly stretched in a horizontal direction, wound on the driving sheave 6, and wound on the counterweight inverting pulley 11. When the main rope descends, it is wound on the counterweight pulley 9. When the main rope ascends, the other end is connected to the upper portion of the hoistway 1 by a second rope retaining fixture 14 disposed at the upper portion of the hoistway 1, corresponding to the counterweight pulley 9.

**[0024]** A part of the main rope 12 that extends from the car inverting pulley 10 to the driving sheave 6 and a part thereof that extends from the driving sheave 6 to the

counterweight inverting pulley 11 intersect with each other in a horizontal projection view. However, the hoisting machine 18 is disposed aslant, and a winding start position and a winding end position of the main rope 12 wound on the driving sheave 6 are vertically shifted; hence, the part extending from the car inverting pulley 10 to the driving sheave 6 and the part extending from the driving sheave 6 to the counterweight inverting pulley 11 do not interfere with each other. Moreover, the arrangement increases the winding angle  $\theta$  of the main rope 12 wound on the driving sheave 6, resulting in an enhanced traction capability.

**[0025]** The car inverting pulley 10 is installed at a position lower than the counterweight inverting pulley 11. This is because the winding start position and the winding end position of the main rope 12 on the driving sheave 6 are vertically shifted.

**[0026]** In the elevator system constructed as set forth above, the hoisting machine 18 is urged, and the driving sheave 6 rotates, causing the car 2 and the counterweight 3 to vertically move in opposite directions from each other via the main rope 12. The hoisting machine 18 is disposed at the upper portion in the hoistway 1 to obviate the need for a machine room independently provided, thereby saving a space for installing the elevator system in a building.

**[0027]** The hoisting machine 18 is installed at an upper end portion of the hoistway 1, and a bottom end of the hoisting machine 18 is disposed above bottom ends of the inverting pulleys 10 and 11. The hoisting machine 18 is provided at an upper position of a side surface of the car 2, the side surface being away from an entrance 15, that is, at a position corresponding to a withdrawal surface 17 of the car 2. The car inverting pulley 10 and the counterweight inverting pulley 11 are disposed in a gap between an edge of the car 2 and an inner wall of the hoistway 1.

**[0028]** Further, the driving sheave 6 is provided on the hoisting machine 18, and the main rope 12 is tightly stretched in a horizontal direction with respect to the driving sheave 6. Thus, the hoisting machine 18 can be installed in the hoistway 1 formed to a height corresponding to a level of a highest floor level (not shown) in a building, and the main rope 12 can be tightly stretched.

**[0029]** Hence, a bottom surface of the ceiling of the hoistway 1 can be brought closer to the car 2, so that the bottom surface of the ceiling of the hoistway 1 does not have to be set higher than the level of the highest floor level in the building, thus reducing a construction cost required for the space for installing the elevator system. In addition to this advantage, the height of the building can be reduced, solving a problem of impairing right to sunshine in a neighborhood.

**[0030]** Moreover, the part of the main rope 12 that extends from the car inverting pulley 10 to the driving sheave 6 and the part thereof that extends from the driving sheave 6 to the counterweight inverting pulley 11 do not interfere with each other and intersect with each other in the horizontal projection view; therefore, the winding

angle  $\theta$  of the main rope 12 wound on the driving sheave 6 increases. Hence, the traction capability can be enhanced.

**[0031]** The enhanced traction capability provides the following advantages.

**[0032]** In the elevator system, when the weight of the car is denoted as  $W_1$ , the weight capacity is denoted as  $W_2$ , and the weight of the counterweight is denoted as  $W_3$ , the counterweight  $W_3$  is set so that  $W_1 + W_2 \times 1/2 = W_3$ . The traction capability of the driving sheave 6 must be adjusted according to a value of  $W_3/W_1$ . In recent years, the weight of a car ( $W_1$ ) is being decreased to reduce cost. In this case, the value of  $W_3/W_1$  increases, so that the traction capability must be enhanced. Therefore, increasing the traction capability permits the weight of a car to be reduced, and cost can be reduced accordingly.

**[0033]** The traction capability is expressed by  $e^{k\theta}$  ( $k$ : constant determined by a groove configuration of a driving sheave; and  $\theta$ : winding angle). To obtain the same traction capability, if the winding angle  $\theta$  can be increased to  $N$  times, then the groove coefficient  $k$  may be only  $1/N$  times.

**[0034]** When a hardness of the driving sheave 6 is denoted as  $H$ , a wear depth of the driving sheave is proportional to  $m/H$ , wherein  $m$  denotes a constant determined by the groove configuration of the driving sheave and it increases or decreases as the groove coefficient  $k$  increases or decreases. To obtain the same traction capability, if the winding angle  $\theta$  can be set to a larger value, then the groove coefficient  $k$  will be smaller and  $m$  will be also smaller. Therefore, an increase in the wear depth can be controlled even if the driving sheave uses a material having a lower hardness  $H$ , thus securing service life of the driving sheave. This makes it possible to select a cheaper material with a lower hardness.

**[0035]** Moreover, as in the case of this embodiment, tension of the main rope 12 can be cancelled by crossing the main rope 12. Fig. 20 shows axial forces required when the start and the end of winding on the driving sheave 6 cross and when they do not cross, respectively. As shown in Fig. 20, when the tension of the main rope 12 is denoted as  $P$ , an axial force of  $2P$  is required when they do not cross, while the axial force is  $2P_1$ , which is smaller than  $2P$ , when they cross, allowing a load applied to the shaft of the driving sheave 6 to be reduced. Hence, the shaft of the driving sheave 6 may be designed to be thinner or to have a lower strength.

50 Second Embodiment (not part of the invention)

**[0036]** Fig. 5 through Fig. 8 show another embodiment. Fig. 5 is a front view conceptually showing a construction of an elevator system in the embodiment, Fig. 6 is a side view of the embodiment shown in Fig. 5, Fig. 7 is a cross top plan view (a vertical projection) of an essential section of the embodiment shown in Fig. 5, and Fig. 8 is a perspective view corresponding to Fig. 7. In the drawings,

like reference numerals as those shown in Fig. 1 through Fig. 4 mentioned previously denote like components.

**[0037]** Reference numeral 20 denotes a hoisting machine that is disposed at an upper corresponding position of a side surface of a car 2 away from an entrance 15, i.e., at a position corresponding to a withdrawal surface 17 of the car 2, and attached to a bottom surface of a ceiling of a hoistway 1. Furthermore, the hoisting machine 20 is provided with a driving sheave 6 pivotally held via a vertical axis, and a driving motor 21 jutting out downward from a bottom surface thereof. The driving sheave 6 of the hoisting machine 20 is positioned near the ceiling of the hoistway 1, while the driving motor 21 is positioned on the opposite side from the ceiling of the hoistway 1 of the hoisting machine 20. The driving sheave 6 has a diameter that is smaller than an outside diameter of the hoisting machine 20. The driving motor 21 is disposed in a gap between an edge of the car 2 and an inner wall of the hoistway 1.

**[0038]** According to this embodiment, the hoisting machine 20 and inverting pulleys 10 and 11 are disposed in an upper portion of a space formed by the car 2 and a side wall of the hoistway 1, in which the counterweight 3 is disposed, so as to effectively use a space required for installing the counterweight 3. The hoisting machine 20 is disposed closely to a corner of the hoistway 1, as can be seen from Fig. 7, which is the cross top view thereof.

**[0039]** The hoisting machine 20 is disposed aslant (disposed aslant as observed sideways) with respect to a horizontal direction so that a portion thereof where the driving motor 21 is mounted is lower, while a portion thereof where the driving motor 21 is not mounted is higher. Furthermore, rotation surfaces of the car inverting pulley 10 and the counterweight inverting pulley 11 are disposed aslant in the cross top view of Fig. 7 so that they cross each other.

**[0040]** The car inverting pulley 10 is installed at a position lower than the counterweight inverting pulley 11. A winding start position and a winding end position of the main rope 12 wound on the driving sheave 6 are vertically shifted. With this arrangement, a part of the main rope 12 extending from the car inverting pulley 10 to the driving sheave 6 and a part extending from the driving sheave 6 to the counterweight inverting pulley 11 do not interfere with each other, and their vertical projections cross. Thus, the winding angle  $\theta$  of the main rope 12 wound on the driving sheave 6, resulting in an enhanced traction capability.

**[0041]** Also in the elevator system constructed as described above, the hoisting machine 20 is installed at an upper end portion of the hoistway 1, and the bottom end of the hoisting machine 20 is placed above the bottom ends of the inverting pulleys 10 and 11. Although the driving motor 21 is provided so that it juts out downward from the bottom surface, the hoisting machine is disposed in a gap between the edge of the car 2 and the inner wall of the hoistway 1. In addition, the hoisting machine 20 is provided at an upper corresponding position

of a side surface of the car 2 away from an entrance 15, i.e., at a position corresponding to a withdrawal surface 17 of the car 2.

**[0042]** Furthermore, the car inverting pulley 10 and the counterweight inverting pulley 11 are disposed in the gap between the edge of the car 2 and the inner wall of the hoistway 1. Hence, the embodiment illustrated in Fig. 5 through Fig. 8 provides the same advantages as those provided by the embodiment illustrated in Fig. 1 through Fig. 4, although detailed explanation will be omitted.

Third Embodiment (not part of the invention)

**[0043]** Fig. 9 through Fig. 11 show still another embodiment. Fig. 9 is a front view conceptually showing the embodiment, Fig. 10 is a cross top plan view (a vertical projection view) of an essential section of the embodiment shown in Fig. 9, and Fig. 11 is a perspective view corresponding to Fig. 10.

**[0044]** In the drawings, like reference numerals as those of Fig. 1 through Fig. 4 mentioned above indicate like components. Reference numeral 22 denotes a main rope that has one end thereof connected to a lower portion of a car 2 at an opposite side from an entrance 15, extends upward to be wound on a car inverting pulley 10 and tightly stretched in a horizontal direction before being wound on a driving sheave 6 and then wound on a counterweight inverting pulley 11, and extends downward to be connected to an upper portion of the counterweight 3.

**[0045]** Furthermore, the car inverting pulley 10 and the counterweight inverting pulley 11 are placed in a gap between an edge of the car 2 and an inner wall of a hoistway 1.

**[0046]** Also in the elevator system constructed as described above, a hoisting machine 18 is installed at an upper end portion of the hoistway 1, and the bottom end of the hoisting machine 18 is placed above bottom ends of the inverting pulleys 10 and 11. In addition, the hoisting machine 18 is provided at an upper corresponding position of a side surface of the car 2 away from the entrance 15, i.e., at a position corresponding to a withdrawal surface 17 of the car 2. The driving sheave 6 in the hoisting machine 18 is positioned on a ceiling side of the hoistway 1. The driving sheave 6 in this embodiment has a diameter that is smaller than an outside diameter of the hoisting machine 18. This arrangement permits effective use of the space formed by the ceiling and the side walls of the hoistway 1.

**[0047]** Furthermore, the hoisting machine 18 is disposed aslant with respect to a horizontal direction (disposed aslant as observed sideways) and positioned near a side wall of the hoistway 1 as much as possible. According to this embodiment, the hoisting machine 18 and inverting pulleys 10 and 11 are disposed in an upper portion of a space wherein the counterweight 3 is disposed, the space being formed by the car 2 and a side wall of the hoistway 1 so as to effectively use a space required for installing the counterweight 3. The hoisting machine

18 is disposed closely to a corner of the hoistway 1 as can be seen from Fig. 10 to thereby minimize a possibility of its interference with the car 2.

[0048] Hence, the embodiment illustrated in Fig. 9 through Fig. 11 provides the same advantages as those provided by the embodiment illustrated in Fig. 1 through Fig. 4, although detailed explanation will be omitted.

Fourth Embodiment. (not part of the invention)

[0049] Fig. 12 through Fig. 14 show yet another embodiment. Fig. 12 is a front view conceptually showing the embodiment, Fig. 13 is a cross top plan view (a vertical projection view) of an essential section of the embodiment shown in Fig. 12, and Fig. 14 is a perspective view corresponding to Fig. 13. In the drawings, like reference numerals as those shown in Fig. 1 through Fig. 4 above denote like components, and descriptions thereof will be omitted.

[0050] Reference numeral 23 denotes a deflector sheave that is provided below a ceiling of the hoistway 1 by a vertical axis, and tightly stretches a main rope 12 between a driving sheave 6 and a car inverting pulley 10 in a direction along an inner wall surface of the hoistway 1. In other words, the deflector sheave 23 changes a direction of the main rope 12 extending from the car inverting pulley 10 to a hoisting machine 18. This structure is effective because it enhances freedom of disposing an inverting pulley in a hoistway.

[0051] In this embodiment, the deflector sheave 23 is disposed so that its rotation surface is horizontal. Further, the deflector sheave 23 is placed at a position where it does not overlap a car 2 in the cross top plan view of Fig. 13, and is disposed at an upper portion of a space wherein a counterweight 3 is disposed, the space being the one between a side surface of the car 2 and an inner wall surface of the hoistway 1.

[0052] Also in the elevator system constructed as set forth above, the hoisting machine 18 is installed at an upper end portion of the hoistway 1, and a bottom end thereof is disposed above bottom ends of inverting pulleys 10 and 11. In addition, the hoisting machine 18 is provided at an upper corresponding position of a side surface of the car 2 away from an entrance 15, i.e., at a position corresponding to a withdrawal surface 17 of the car 2. In addition, the car inverting pulley 10 and the counterweight inverting pulley 11 are disposed in a gap between an edge of the car 2 and an inner wall of the hoistway 1.

[0053] Thus, the embodiment illustrated in Fig. 12 through Fig. 14 provides the same advantages as those provided by the embodiment illustrated in Fig. 1 through Fig. 4, although detailed explanation will be omitted.

[0054] In the embodiment shown in Fig. 12 through Fig. 14, the deflector sheave 23 causes the main rope 12 between the driving sheave 6 and the car inverting pulley 10 to be tightly stretched in a direction along the inner wall surface of the hoistway 1. Hence, a side surface

of the car inverting pulley 10 can be disposed in parallel to the inner wall surface of the hoistway 1. This makes it possible to reduce a width of the gap between the edge of the car 2 and the inner wall of the hoistway 1, permitting a further reduction in a space for the elevator system in a building. There is another advantage in that a winding angle  $\theta$  of the main rope 12 wound on the driving sheave 6 can be increased.

[0055] Moreover, the deflector sheave 23 does not overlap the car 2 in a vertical projection, and is disposed in the gap between the car 2 and the hoistway 1. This permits prevention of interference between the car 2 and the deflector sheave 23 and therefore obviates the need for a space required for preventing the interference.

Fifth Embodiment (not part of the invention)

[0056] Fig. 15 through Fig. 17 show a further embodiment. Fig. 15 is a front view conceptually showing the embodiment, Fig. 16 is a cross top plan view (a vertical projection view) of an essential section of the embodiment shown in Fig. 15, and Fig. 17 is a perspective view corresponding to Fig. 16. In the drawings, like reference numerals as those shown in Fig. 12 through Fig. 14 above denote like components, and descriptions thereof will be omitted. Reference numeral 24 denotes a counterweight, which is provided in a gap between an outer edge of a car 2 that is connected to an entrance 15, and an inner wall surface of the hoistway 1. More specifically, the counterweight 24 is disposed in a space between a side surface of the car 2 that is adjacent to a surface wherein the entrance 15 is formed, and the inner wall surface of the hoistway 1.

[0057] Reference numeral 23 denotes a deflector sheave that is provided below a ceiling of the hoistway 1 by a vertical axis, and tightly stretches a main rope 12 between a driving sheave 6 and a car inverting pulley 10 in a direction along the inner wall surface of the hoistway 1. In other words, the deflector sheave 23 changes a direction of the main rope 12 extending from the car inverting pulley 10 to a hoisting machine 18. In this embodiment, the deflector sheave 23 is disposed so that its rotation surface is horizontal.

[0058] Also in the elevator system constructed as set forth above, the hoisting machine 18 is installed at an upper end portion of the hoistway 1, and a bottom end thereof is disposed above bottom ends of inverting pulleys 10 and 11. In addition, the hoisting machine 18 is provided at an upper corresponding position of a side surface of the car 2 away from an entrance 15, i.e., at a position corresponding to a withdrawal surface 17 of the car 2. In addition, the car inverting pulley 10 and the counterweight inverting pulley 11 are disposed in a gap between an edge of the car 2 and the inner wall of the hoistway 1.

[0059] The deflector sheave 23 causes the main rope 12 between the driving sheave 6 and the car inverting pulley 10 to be tightly stretched in a direction along the

inner wall surface of the hoistway 1. Hence, a side surface of the car inverting pulley 10 can be disposed in parallel to the inner wall surface of the hoistway 1.

**[0060]** Thus, the embodiment illustrated in Fig. 15 through Fig. 17 provides the same operations and advantages as those provided by the embodiment illustrated in Fig. 12 through Fig. 14, although detailed explanation will be omitted.

#### Sixth Embodiment

**[0061]** In this embodiment, descriptions will be given particularly of a structure of a mounting base for fixing a hoisting machine, inverting pulleys 10 and 11, and a deflector sheave 23 in a hoistway 1.

**[0062]** Fig. 18 is a side view showing a state wherein the mounting base for fixing the hoisting machine, the inverting pulleys 10 and 11, and the deflector sheave 23 has been installed, and Fig. 19 is a cross top plan view (a vertical projection) thereof.

**[0063]** Reference numeral 25 denotes a mounting base. The mounting base is integrally fixed to beams passed through two guide rails of the car 2 and two guide rails of a counterweight. On the mounting base 25, the hoisting machine is mounted aslant with respect to a horizontal direction, rotating shafts of the inverting pulleys 10 and 11 are mounted, and a rotating shaft of the deflector sheave 23 are also mounted. The hoisting machine, the inverting pulleys 10 and 11, and the deflector sheave 23 are fixed to the mounting base 25 that is integrally fixed; therefore, a positional relationship of these components is established when the mounting base 25 is assembled, thus allowing easy adjustment at the time of installing an elevator. Moreover, since all load applied to the hoisting machine, the inverting pulleys 10 and 11, and the deflector sheave 23 is supported by the four guide rails via the mounting base 25, a strength of the hoistway 1 does not have to be considered.

**[0064]** In this embodiment, the mounting base 25 is secured to the two guide rails of the car 2 and the two guide rails of the counterweight. Alternatively, however, the mounting base 25 may be installed to an inner wall of the hoistway 1 if the wall of the hoistway 1 is sufficiently strong.

**[0065]** Of the embodiments described above, the ones that are not provided with the deflector sheave 23 may use the mounting base 25.

#### Seventh Embodiment (not part of the invention)

**[0066]** Fig. 21 and Fig. 22 show this embodiment, wherein Fig. 21 is a side view and Fig. 22 is a cross top plan view (a vertical projection) of an essential section.

**[0067]** This embodiment is similar to a previous embodiment in that the hoisting machine is disposed aslant with respect to a horizontal direction below a ceiling of a hoistway 1, but it is different therefrom in that a vertical projection of a part of a main rope 12 that extends from

a car inverting pulley 10 to a driving sheave 6 does not intersect with a vertical projection of a part thereof that extends from the driving sheave 6 to a counterweight inverting pulley 11.

**[0068]** In the drawings, like reference numerals as those of Fig. 15 through Fig. 17 will denote like components, and descriptions thereof will be omitted. A hoisting machine 18 in this embodiment is also provided with the driving sheave 6 that is located on a ceiling side and has a diameter smaller than that of the hoisting machine 18. This allows effective use of a corner space formed by the ceiling of the hoistway 1 and an inner wall of the hoistway 1.

**[0069]** In this embodiment, the part of the main rope 12 that extends from the car inverting pulley 10 to the driving sheave 6 and the part thereof that extends from the driving sheave 6 to the counterweight inverting pulley 11 do not intersect with each other as shown in Fig. 22. However, since the hoisting machine 18 is set aslant with respect to the horizontal direction, a rope deflection angle formed by the inverting pulley 11 and a deflector sheave 23 can be reduced as compared with a conventional example.

**[0070]** Moreover, a dimension B from a ceiling of the car 2 and a ceiling of the hoistway 1 when the car 2 has reached its highest position can be made smaller than a dimension A that would be required if the hoisting machine 18 were disposed horizontally.

#### Eighth Embodiment (not part of the invention)

**[0071]** Another embodiment wherein a hoisting machine is disposed aslant with respect to a horizontal direction below a ceiling of a hoistway 1 will now be described.

**[0072]** Fig. 23 and Fig. 24 show this embodiment, wherein Fig. 23 is a front view and Fig. 24 is a cross top plan view (a vertical projection) of an essential section.

**[0073]** In the drawings, like reference numerals as those of Fig. 15 through Fig. 17 mentioned above will denote like components, and descriptions thereof will be omitted.

**[0074]** A hoisting machine 18 is disposed at a top portion of a hoistway 1 in a state wherein it is inclined by an angle  $\alpha$  in relation to the horizontal direction. A part of the hoisting machine 18 overlaps a car 2 in a vertical projection, and the rest thereof is positioned above a gap between the car 2 and a wall of the hoistway, especially in a gap between the car 2 and the wall of the hoistway at a side where a counterweight 24 is disposed. Since the hoisting machine 18 is inclined, the part of the hoisting machine 18 that overlaps the car 2 is closer to the ceiling of the hoistway than the part above the gap. A driving sheave 6 is installed on a ceiling side of the hoisting machine 18, and the driving sheave 6 is also inclined by the angle  $\alpha$  as in the case of the hoisting machine 18. The driving sheave 6 has a diameter that is smaller than that of a motor portion of the hoisting machine.

**[0075]** This embodiment is not provided with a deflector sheave. Hence, a main rope 12 extends from a car inverting pulley 10 to the driving sheave 6 without an intermediary of the deflector sheave, and further from the driving sheave 6 to the counterweight inverting pulley 11.

**[0076]** The counterweight inverting pulley 11 is positioned above a gap between the car 2 and the wall of the hoistway at a side where the counterweight 24 is disposed, and it is positioned under the car inverting pulley 10 (in a direction away from the ceiling of the hoistway). The car inverting pulley 10 and the counterweight inverting pulley 11 are provided so that their rotation surfaces are substantially vertical.

**[0077]** Disposing the hoisting machine aslant with respect to the horizontal direction below the ceiling of the hoistway 1 as in this embodiment is an effective means for securing a service lives of the groove of the driving sheave 6 and the main rope 12. This aspect will now be described in more detail.

**[0078]** Fig. 25 provides views illustrating a positional relationship between the driving sheave 6 and the counterweight inverting pulley 11 in a conventional elevator system shown in Fig. 34. The views of Fig. 25 illustrate a state wherein sheave grooves of the driving sheave 6 are horizontal, sheave grooves of the counterweight inverting pulley 11 are disposed vertically, and the main rope 12 is wound between two sheave grooves. Fig. 25 (b) is a view obtained by observing the state shown in Fig. 25 (a) from a direction of an arrow. Fig. 25 (b) shows a case wherein the main rope 12 is composed of three ropes. A rope 12a is set at a position shifted by a distance a1 when moving from the sheave grooves of the driving sheave 6 to the sheave grooves of the counterweight inverting pulley 11.

**[0079]** In Fig. 25,  $\theta_1$  denotes a fleet angle. In the case shown in Fig. 25, the fleet angle  $\theta_1$  can be calculated as follows:

$$\theta_1 = \text{Arctan} (a_1/L)$$

**[0080]** The fleet angle  $\theta_1$  is a value indicative of a misalignment amount between a sheave groove of the driving sheave 6 and a sheave groove of the counterweight inverting pulley 11 in which the main rope 12 passes. As the value increases, the main rope 12 strikes side surfaces of the sheave grooves more hardly, adding to wearing force on the main rope 12 and the sheave grooves. More specifically, as shown in Fig. 26, if a tension of the main rope 12 is represented by T, and a coefficient of friction between the sheave grooves and the main rope 12 is represented by  $\mu$  when the fleet angle is  $\theta_1$ , then a force of  $T \sin \theta$  is applied to the side surfaces of the sheave grooves, generating a frictional force of  $\mu T \sin \theta$ .

**[0081]** There is a problem in that the frictional force leads to a shortened service lives of the main rope 12 and the sheave grooves. Generally, in the case of an

elevator, it is known to be necessary to set the fleet angle  $\theta_1$  to 1.5 degrees or less in order to secure the service lives.

**[0082]** If the hoisting machine 18 is inclined by the angle  $\alpha$  with respect to the horizontal direction as in this embodiment, then a positional relationship shown in Fig. 27 is established. Fig. 27 (b) is a view obtained by enlarging a circle portion shown in Fig. 27 (a). In the case of Fig. 27, the rope 12a is set at a position shifted by a distance a2 when moving from the sheave grooves of the driving sheave 6 to the sheave grooves of the counterweight inverting pulleys 11. Since the hoisting machine 18 is inclined, the distance a2 is expression by a relationship  $a_2 < a_1$ .

**[0083]** And the fleet angle  $\theta_2$  is expressed as  $\theta_2 = \text{Arctan}(a_2/L)$ .

**[0084]** The relationship between the fleet angles  $\theta_1$  and  $\theta_2$  is expressed as fleet angle  $\theta_2 <$  fleet angle  $\theta_1$ ; therefore, the service lives of the main rope 12 and the sheave grooves can be prolonged by installing the hoisting machine 18 aslant.

**[0085]** Next, a relationship between the tilt angle  $\alpha$  and a decreasing amount of a2 is as shown in Fig. 28. As can be seen in the graph, the distance a2 suddenly decreases at a smaller value of the angle  $\alpha$ , and it gently changes as the angle  $\alpha$  approaches 90 degrees. Based on the graph, it can be understood that slightly inclining the hoisting machine 18 reduces the fleet angle  $\theta_2$ , providing a great advantage.

**[0086]** As explained above, by inclining the hoisting machine 18 in relation to the horizontal direction, the effective advantage in securing the service lives of the sheave grooves of the driving sheave 6 and the main rope 12 can be obtained.

**[0087]** In designing, however, the tilt angle  $\alpha$  to be set is decided according to other factors, such as a relationship with a space for the hoistway. For example, as the angle  $\alpha$  is increased, a top of the hoistway must be set higher. This results in higher building cost. For this reason, it is required in designing to set the tilt angle  $\alpha$  of the hoisting machine within a range of a compromise between reasonable service lives of the sheave grooves of the driving sheave 6 and the main rope 12, and the building cost.

**[0088]** The advantage of prolonged service lives of the sheave grooves of the driving sheave 6 and the main rope 12 is the same advantage obtained in the previous embodiment wherein the hoisting machine is disposed aslant with respect to the horizontal direction.

**[0089]** The hoisting machine 18 in this embodiment is also provided with a driving sheave 6 having a diameter that is smaller than an outside diameter of the hoisting machine 18 and provided on the ceiling side. This arrangement permits effective use of a corner space formed by the ceiling of the hoistway 1 and the inner wall of the hoistway 1.

## Ninth Embodiment (not part of the invention)

**[0090]** Fig. 29 and Fig. 30 show this embodiment, wherein Fig. 29 is a front view and Fig. 30 is a cross top plan view (a vertical projection) of an essential section.

**[0091]** In the drawings, like reference numerals as those of Fig. 15 through Fig. 17 mentioned above will denote like components, and descriptions thereof will be omitted.

**[0092]** A hoisting machine 18 is horizontally disposed in a top portion of a hoistway, while a car inverting pulley 10 and a counterweight inverting pulley 11 are disposed so that rotation surfaces thereof are inclined by an angle  $\alpha$  with respect to a vertical direction. Hence, although the hoisting machine 18 is horizontally disposed, a movement amount  $a_2$  and a fleet angle  $\theta_2$  when a main rope 12 moves from sheave grooves of a driving sheave 6 to sheave grooves of the counterweight inverting pulley 11 will be the same values as those in the eighth embodiment. This means that the service lives of the main rope 12 and the sheave grooves can be made longer than before.

**[0093]** A part of the hoisting machine 18 overlaps a car 2 in a vertical projection, and the rest thereof is positioned above a gap between the car 2 and a wall of the hoistway.

**[0094]** This embodiment is not provided with a deflector sheave. Hence, the main rope 12 extends from the car inverting pulley 10 to the driving sheave 6 without an intermediary of the deflector sheave, and further from the driving sheave 6 to the counterweight inverting pulley 11.

**[0095]** The counterweight inverting pulley 11 is positioned above a gap between the car 2 and the wall of the hoistway at a side where a counterweight 24 is disposed. And the car inverting pulley 10 and the counterweight inverting pulley 11 are installed substantially at the same height.

**[0096]** The eighth and ninth embodiments are both intended for reductions in the fleet angle from the hoisting machine 18 to the inverting pulleys 10 and 11. It is possible to combine these embodiments. More specifically, the hoisting machine 18 may be inclined in relation to the horizontal direction, and the rotation surfaces of the inverting pulleys 10 and 11 may also be disposed aslant in relation to the vertical direction.

## Tenth Embodiment

**[0097]** In this embodiment, a mounting base for fixing a hoisting machine 18 and inverting pulleys 10 and 11 in a hoistway 1 will be described.

**[0098]** Fig. 31 is a cross top plan view (a vertical projection) showing the mounting base for fixing the hoisting machine 18 and the inverting pulleys 10 and 11 has been installed.

**[0099]** Reference numeral 25 denotes a mounting base secured to tops of guide rails. The mounting base is integrally fixed to beams passed through two guide rails of the car 2 and two guide rails of a counterweight,

and these beams are joined to constitute an integral-type mounting base. On the mounting base 25, the hoisting machine 18 is horizontally disposed, and the car inverting pulley 10 and the counterweight inverting pulley 11 are also fixed to the common mounting base 25. The inverting pulleys 10 and 11 may alternatively be disposed on the mounting base of this embodiment such that the rotation surfaces thereof are disposed aslant with respect to the vertical direction as in the case of the ninth embodiment, providing similar advantages as described below.

**[0100]** A positional relationship between the hoisting machine 18, and the inverting pulleys 10 and 11 are established by installing the mounting base 25; therefore, thus allowing easy adjustment at the time of installing an elevator. Moreover, since all load applied to the hoisting machine, the inverting pulleys 10 and 11, and a deflector sheave 23 is supported by the four guide rails via the mounting base 25, a strength of the hoistway 1 does not have to be considered.

**[0101]** Installing the hoisting machine 18 and the inverting pulleys 10 and 11 on the integral-type mounting base 25 is advantageous also in the following aspects.

**[0102]** Fig. 32 is a view illustrating horizontal forces observed when the hoisting machine 18 and the inverting pulleys 10 and 11 are installed to the integral-type mounting base 25. Fig. 33 is a view illustrating vertical forces observed when the hoisting machine 18 and the inverting pulleys 10 and 11 are installed to the integral-type mounting base 25.

**[0103]** A main rope 12 is wound between the driving sheave 6 of the hoisting machine 18 and the car inverting pulley 10, and between the driving sheave 6 and the counterweight inverting pulley 11. When a tension applied to the main rope 12 is denoted as T, forces T are applied to the driving sheave 6 in an axial direction of the main rope 12 as shown in Fig. 32. Furthermore, tensions T are also applied to the car inverting pulley 10 and the counterweight inverting pulley 11. These forces are also applied to the mounting base 25 via a support portion of the driving sheave 6, and shaft portions of the inverting pulleys 10 and 11; however, vector directions of the tensions T are the same, so that they turn into compressive forces that cancel each other.

**[0104]** If a structural strength of the mounting base 25 is secured in advance, then the forces are balanced in the mounting base 25. Therefore, the car guide rails and the counterweight guide rails that support the mounting base 25 are not subjected to the forces.

**[0105]** If a weight of the hoisting machine 18, the car inverting pulley 10, the counterweight inverting pulley 11, and the mounting base 25 is denoted as W, then the vertical forces will be  $2T+W$  as shown in Fig. 33. The forces will be received by the car guide rails and the counterweight guide rails. The forces are all axial forces of the guide rails, and ideally applied because the rails are the strongest in the axial direction.

**[0106]** This advantage is the same as that provided by the mounting base 25 described in the sixth embodiment

set forth above.

**[0107]** In this embodiment, the driving sheave 6 is provided at an upper side (ceiling side) of the hoisting machine 18, and the main rope 12 is positioned on the ceiling side of the mounting base 25. The shafts of both inverting pulleys 10 and 11 are secured to a lower surface of the mounting base 25, and in a fixation longitudinal section, the main rope 12 wound on the inverting pulleys 10 and 11 juts out to the ceiling side of the mounting base 25, and bottom ends of the inverting pulleys 10 and 11 jut out from a lower side of the mounting base 25. In other words, the driving sheave 6 is positioned on an upper or lower surface of the mounting base 25 that is the opposite surface from the one where the car 2 or the counterweight 24 is positioned, and the winding of the main rope 12 on the inverting pulleys 10 and 11 is also positioned on the opposite surface. With this arrangement, the mounting base 25 is positioned between the top ends and the bottom ends of the inverting pulleys 10 and 11 in the longitudinal section.

**[0108]** Such a structure is effective for reducing a space in a direction of height for installing the mounting base 25, the hoisting machine 18, and the inverting pulleys 10 and 11. When the driving sheave 6 is provided on the lower side of the hoisting machine 18 as shown in Fig. 34, the space in the direction of height for installing the mounting base 25, the hoisting machine 18, and the inverting pulleys 10 and 11 will have a distance of S1. In the case of this embodiment, however, the driving sheave 6 is provided on the upper side (the ceiling side) of the hoisting machine 18, and the main rope 12 is positioned on the ceiling side of the mounting base 25. Hence, the space in the direction of height for installing the mounting base 25, the hoisting machine 18, and the inverting pulleys 10 and 11 will be able to have a distance S2, which is smaller than S1. In this embodiment, both rotating shafts of the inverting pulleys 10 and 11 are fixed to the lower surface of the mounting base 25, and the winding of the main rope 12 juts out to the ceiling side of the mounting base 25. The same advantage can be obtained even when either one of the rotating shafts is disposed as described above.

**[0109]** Furthermore, both terminals of the main rope 12 are fixed to the mounting base 25. This obviates the need for separately providing a bracket for fixing the main rope. If both terminals of the main rope are attached to a building or guide rails as in a prior art, tensions of the main rope are intensively applied to the attached portions, thus requiring the building and the guide rails be strong. It is alternatively possible to attach both terminals of the main rope to the mounting base 25, and to support the mounting base 25 by a plurality of guide rails to thereby spread a supporting force.

**[0110]** The structure set forth above can be applied also to the mounting base 25 of the sixth embodiment.

**[0111]** In the present embodiment, the mounting base 25 is fixed to the upper portions of the two guide rails of the car 2 and the two guide rails of the counterweight. If,

however, a wall of a hoistway 1 has a sufficiently high strength, then the mounting base 25 may be installed to the inner wall of the hoistway 1. Alternatively, the mounting base 25 may be fixed only to the guide rails of the car 2 or only to the guide rails of the counterweight. Further alternatively, a few of the foregoing four guide rails may be selected and fixed.

[Advantage of the Invention]

**[0112]** The elevator system in accordance with the present invention has a car that moves in a hoistway, a counterweight that moves in the hoistway, a main rope that suspends the car and the counterweight, and a hoisting machine on which the main rope is wound and which moves the car and the counterweight up and down via the main rope, wherein the hoisting machine is disposed aslant with respect to a horizontal direction in the hoistway. With this arrangement, a space for the elevator system in a building can be decreased.

**[0113]** The counterweight is disposed in a gap between a wall of the hoistway and the car, and the hoisting machine is disposed above the gap wherein the counterweight is disposed. This arrangement makes it possible to effectively use a gap required for installing the counterweight.

**[0114]** A part of the hoisting machine overlaps the car in a vertical projection and the rest thereof is positioned between the car and the wall of the hoistway, the part being closer to a ceiling of the hoistway than the rest is. Hence, a ceiling bottom surface of the hoistway 1 can be brought closer to the car 2, contributing to space saving.

**[0115]** The hoisting machine has a driving sheave on which the main rope is wound, and the driving sheave is disposed so that it opposes to the ceiling of the hoistway. This arrangement makes it possible to effectively use the space formed by the ceiling and a side wall of the hoistway 1.

**[0116]** The elevator system further includes a first inverting pulley on which a first part of the main rope that extends from the car to the hoisting machine is wound, and a second inverting pulley on which a second part of the main rope that extends from the hoisting machine to the counterweight is wound, wherein a vertical projection of the first part of the main rope and a vertical projection of the second part of the main rope with each other. This arrangement makes it possible to increase a winding angle of the main rope wound on the hoisting machine and to increase a traction capability.

**[0117]** The first inverting pulley and the second inverting pulley are disposed between the car and the wall of the hoistway in a vertical projection. With this arrangement, the car can be positioned at a higher level than the inverting pulleys.

**[0118]** The elevator system further includes a first inverting pulley on which a part of the main rope that extends from the car to the hoisting machine is wound, a second inverting pulley on which a part of the main rope

that extends from the hoisting machine to the counterweight is wound, and a deflector sheave which is provided in the hoistway and which changes a direction of the main rope extending from the first inverting pulley to the hoisting machine or the direction of the main rope extending from the second inverting pulley to the hoisting machine. Hence, the freedom of disposing the inverting pulleys in the hoistway can be increased.

**[0119]** A rotation surface of the first inverting pulley or the second inverting pulley is parallel to the wall of the hoistway. This arrangement makes it possible to reduce the gap, wherein the inverting pulleys are disposed, between the car and the wall of the hoistway.

**[0120]** The deflector sheave is disposed at an upper portion of the hoistway such that a rotation surface thereof is horizontal, thus permitting effective use of the space of the upper portion of the hoistway.

**[0121]** The first inverting pulley, the second inverting pulley, and the hoisting machine are mounted on a common mounting base. Hence, the positional relationship between the first inverting pulley, the second inverting pulley, and the hoisting machine is established when the mounting base is assembled, thus permitting easier positional adjustment of these components.

**[0122]** The mounting base is disposed at an upper portion of the hoistway. This arrangement permits prevention of a failure of the hoisting machine caused by flood.

**[0123]** The elevator system in accordance with the present invention has a car that moves in a hoistway, a counterweight that moves in the hoistway, a main rope that suspends the car and the counterweight, and a hoisting machine on which the main rope is wound and which moves the car and the counterweight up and down via the main rope, further including a first inverting pulley on which a part of the main rope that extends from the car to the hoisting machine is wound, and a second inverting pulley on which a part of the main rope that extends from the hoisting machine to the counterweight is wound, wherein a rotation surface of at least one of the first inverting pulley and the second inverting pulley is disposed substantially perpendicularly, and the hoisting machine is disposed aslant with respect to a horizontal direction in the hoistway. With this arrangement, the fleet angle can be decreased, and the service life of the main rope, etc. can be prolonged.

**[0124]** The elevator system in accordance with the present invention has a car that moves in a hoistway, a counterweight that moves in the hoistway, a main rope that suspends the car and the counterweight, and a hoisting machine on which the main rope is wound and which moves the car and the counterweight up and down via the main rope, further including a first inverting pulley on which a part of the main rope that extends from the car to the hoisting machine is wound, and a second inverting pulley on which a part of the main rope that extends from the hoisting machine to the counterweight is wound, wherein the hoisting machine is disposed substantially horizontally in the hoistway, and a rotation surface of at

least one of the first inverting pulley and the second inverting pulley is disposed aslant with respect to a vertical direction in the hoistway. With this arrangement, the fleet angle can be decreased, and the service life of the main rope, etc. can be prolonged.

**[0125]** The elevator system in accordance with the present invention has a car that moves in a hoistway, a counterweight that moves in the hoistway, a main rope that suspends the car and the counterweight, and a hoisting machine on which the main rope is wound and which moves the car and the counterweight up and down via the main rope, further including a first inverting pulley on which a part of the main rope that extends from the car to the hoisting machine is wound, and a second inverting pulley on which a part of the main rope that extends from the hoisting machine to the counterweight is wound, wherein the hoisting machine is disposed substantially horizontally or aslant with respect to a horizontal direction in the hoistway, and the hoisting machine, the first inverting pulley, and the second inverting pulley are disposed on a common mounting base provided in the hoistway. With this arrangement, horizontal forces generated by the tension of the main rope can be cancelled with each other.

**[0126]** The hoisting machine has a driving sheave on which the main rope is wound, the driving sheave is positioned on a top or bottom surface of the mounting base that is at an opposite side from a position where the car or the counterweight is located, and winding of the main rope on at least one of the first inverting pulley or the second inverting pulley is positioned at the opposite side. This arrangement makes it possible to reduce the space in the height direction for installing the hoisting machine, the mounting base, and the inverting pulleys.

**[0127]** Both ends of the main rope are secured to the mounting base. Therefore, the tension applied to the main rope can be spread in supporting it.

[Description of Reference Numerals]

**[0128]**

1	Hoistway
2	Car
3	Counterweight
6	Driving sheave
10	Car inverting pulley
11	Counterweight inverting pulley
12	Main rope
15	Entrance
17	Withdrawal surface
18	Hoisting machine
20	Hoisting machine
21	Driving motor
22	Main rope
23	Deflector sheave
24	Counterweight

## Claims

### 1. An elevator system comprising:

a car (2) that moves in a hoistway (1);  
 a counterweight (3) that moves in the hoistway;  
 a suspension rope that suspends the car and the counterweight;  
 and a hoisting machine (18) on which the suspension rope is wound and which moves the car and the counterweight up and down via the suspension rope, further comprising a first inverting pulley (10) on which a first part of the suspension rope that extends from the car to the hoisting machine is wound, and a second inverting pulley (11) on which a second part of the suspension rope that extends from the hoisting machine to the counterweight is wound,  
 wherein the hoisting machine, the first inverting pulley, and the second inverting pulley are disposed on a common mounting base (25) provided in the hoistway, **characterized in that**  
 a part of the hoisting machine (18) overlaps the car in a vertical projection and the rest thereof is positioned between the car and the wall of the hoistway (1), the hoisting machine (18) being inclined so that the part overlapping the car (2) is closer to the ceiling of the hoistway (1) than the rest is.

2. An elevator system according to claim 1, wherein the mounting base is disposed at an upper portion of the hoistway.
3. An elevator system according to claim 1, wherein the mounting base is secured to tops of guide rails.

## Patentansprüche

### 1. Liftsystem aufweisend:

eine Kabine (2), die sich in einem Aufzugschacht (1) bewegt;  
 ein Gegengewicht (3), das sich im Aufzugschacht bewegt; ein Aufhängeseil, das die Kabine (2) und das Gegengewicht aufhängt;  
 und eine Hubvorrichtung (18), an der das Aufhängeseil gewunden ist und welche die Kabine und das Gegengewicht durch das Aufhängeseil hinauf und hinunter bewegt, weiter aufweisend eine erste Umlenkrolle (10), an der ein erster Teil des sich von der Kabine zur Hubvorrichtung erstreckenden Aufhängeseils gewunden ist, und eine zweite Umlenkrolle (11), an der ein zweiter Teil des sich von der Hubvorrichtung zum Gegengewicht erstreckenden Aufhängeseils gewunden ist,

wobei die Hubvorrichtung, die erste Umlenkrolle und die zweite Umlenkrolle an einer gemeinsamen, im Aufzugschacht vorgesehenen Befestigungsbasis (25) angebracht sind, **dadurch gekennzeichnet, dass**  
 ein Teil der Hubvorrichtung (18) die Kabine in einer vertikalen Projektion überlappt, und der Rest hiervon zwischen der Kabine und der Wand des Aufzugschachtes (1) gelegen ist, wobei die Hubvorrichtung (18) derart geneigt ist, dass der die Kabine (2) überlappende Teil näher zur Decke des Aufzugschachtes (1) als der Rest ist.

2. Liftsystem gemäß Anspruch 1, bei dem die Befestigungsbasis an einem oberen Bereich des Aufzugschachtes angeordnet ist.
3. Liftsystem gemäß Anspruch 1, bei dem die Befestigungsbasis an Spitzen von Führungsschienen gesichert ist.

## Revendications

### 1. Système d'ascenseur comprenant :

une cabine (2) qui se déplace dans une gaine (1) ;  
 un contrepoids (3) qui se déplace dans la gaine ;  
 un câble de suspension (12) qui suspend la cabine et le contrepoids ;  
 et une machine de levage (18) sur laquelle le câble de suspension est enroulé et qui déplace la cabine et le contrepoids vers le haut et vers le bas via le câble de suspension, comprenant en outre une première poulie d'inversion (10) sur laquelle une première partie du câble de suspension qui s'étend de la cabine jusqu'à la machine de levage est enroulée, et une deuxième poulie d'inversion (11) sur laquelle une deuxième partie du câble de suspension qui s'étend de la machine de levage jusqu'au contrepoids est enroulée,  
 dans lequel la machine de levage, la première poulie d'inversion, et la deuxième poulie d'inversion sont disposées sur une base de montage (25) commune prévue dans la gaine, **caractérisé en ce que**  
 une partie de la machine de levage chevauche la cabine selon une projection verticale et le reste de la machine de levage est positionnée entre la cabine et la paroi de la gaine (1), la machine de levage (18) étant inclinée de sorte que la partie chevauchant la cabine (2) est plus proche du plafond de la gaine que le reste de la cabine ne l'est.

2. Système d'ascenseur selon la revendication 1, dans lequel la base de montage commune est disposée à une partie supérieure de la gaine.
3. Système d'ascenseur selon la revendication 1, dans lequel la base de montage commune est attachée sur le dessus de rails de guidage.

5

10

15

20

25

30

35

40

45

50

55

FIG. 1

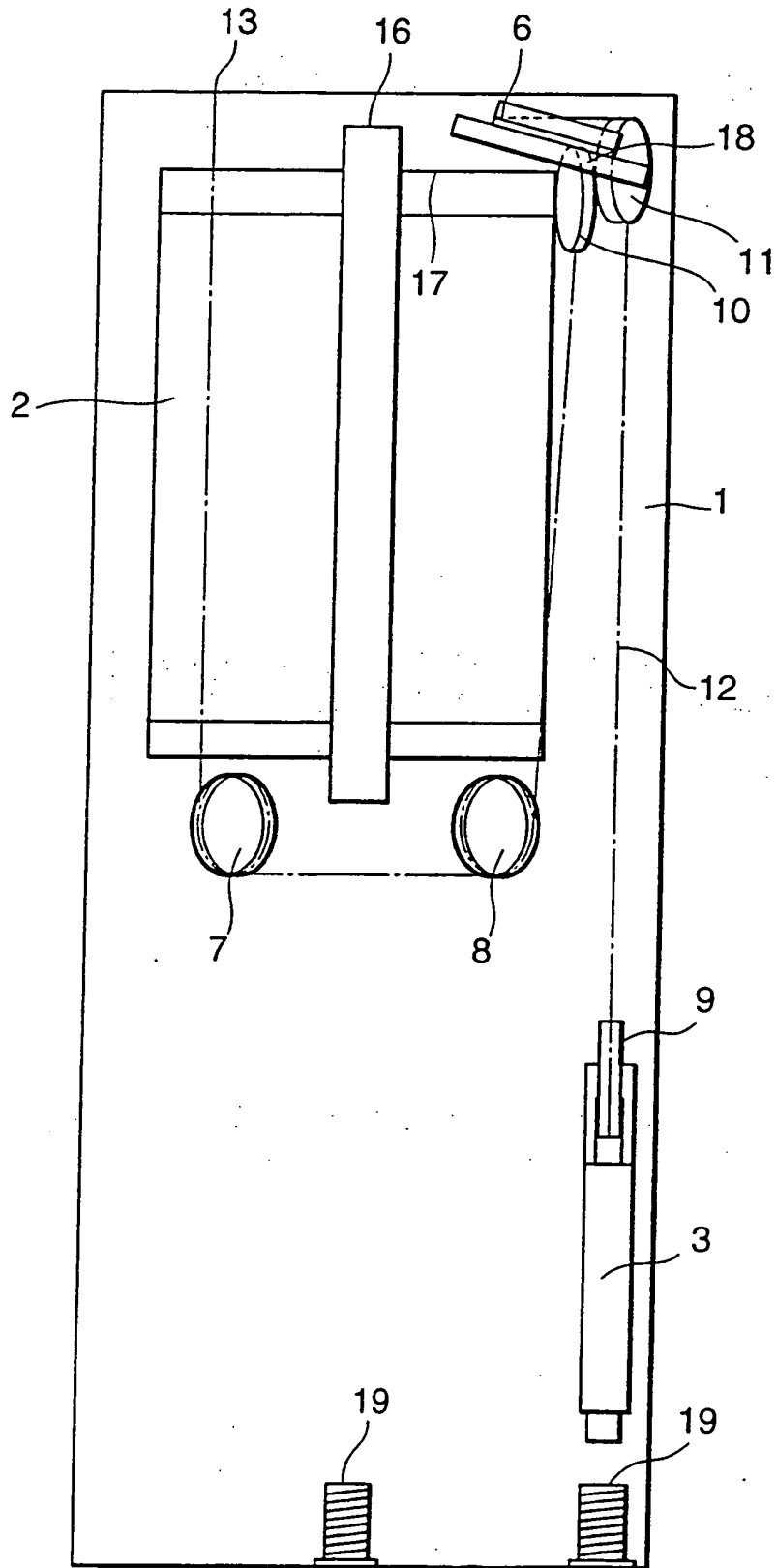

FIG. 2

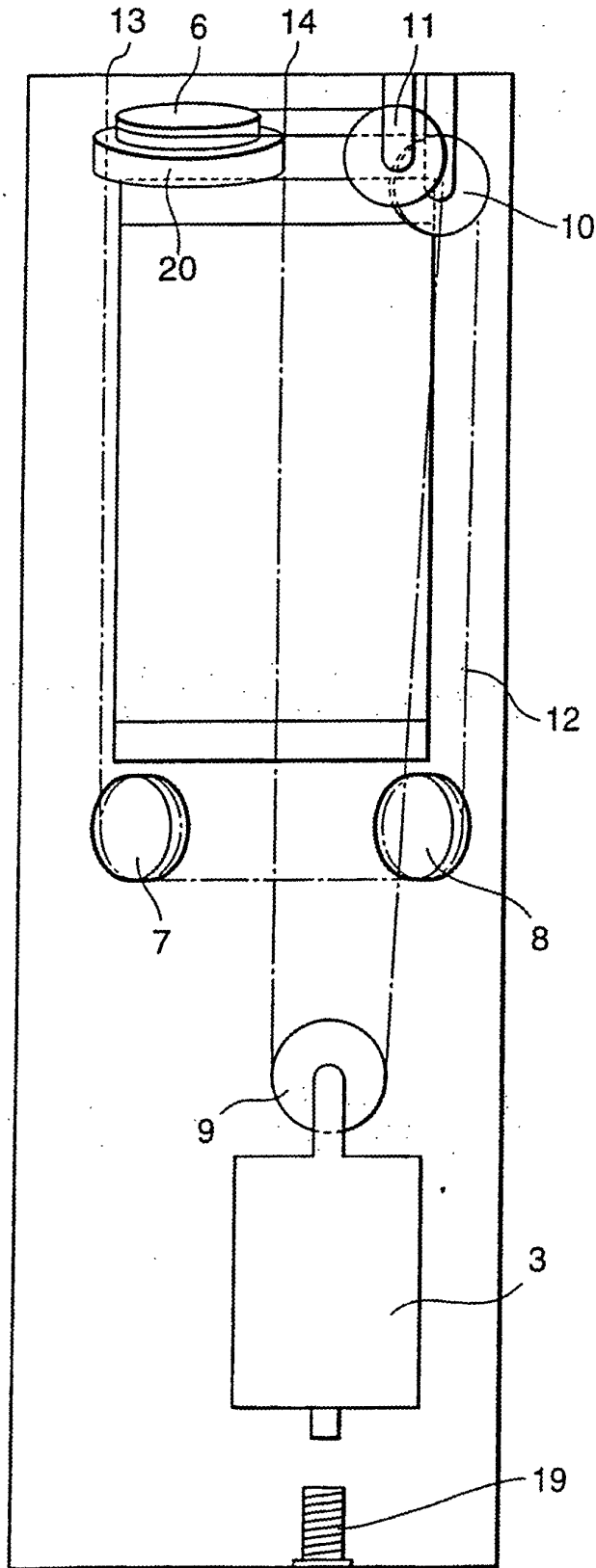

FIG. 3

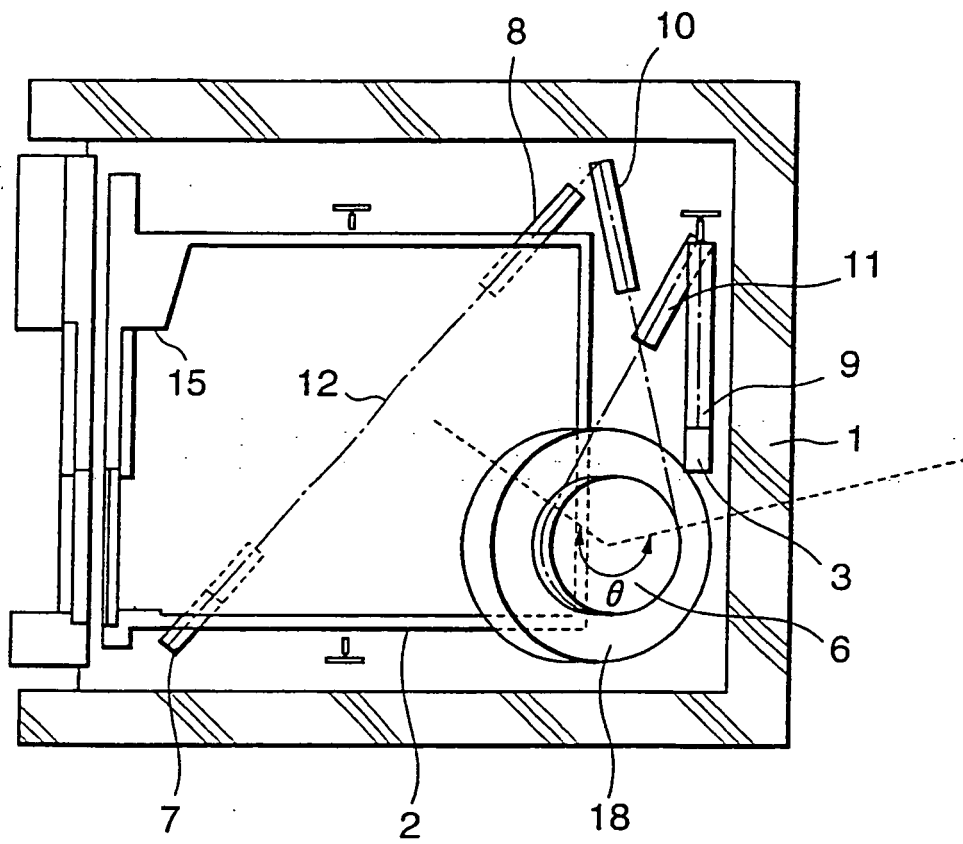



FIG. 5

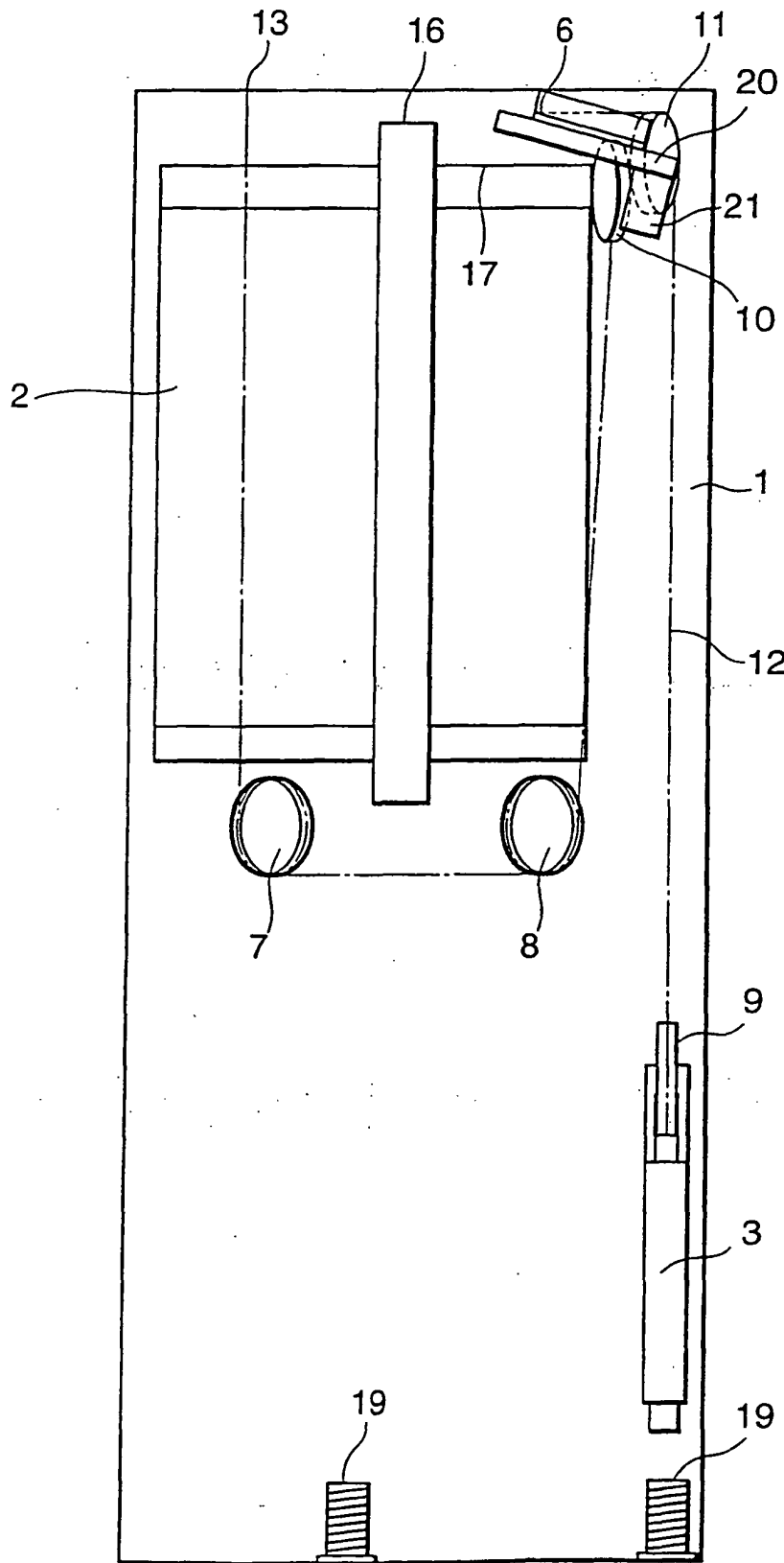

FIG. 6

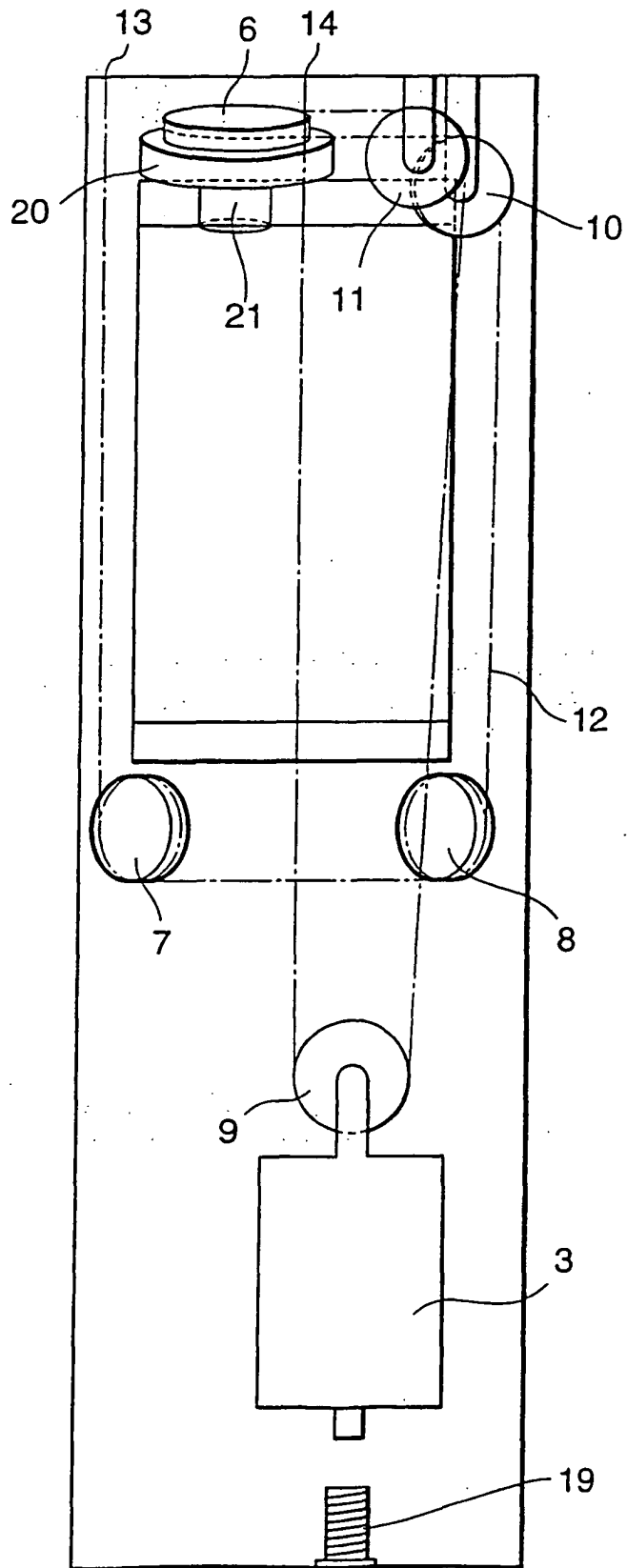

FIG. 7

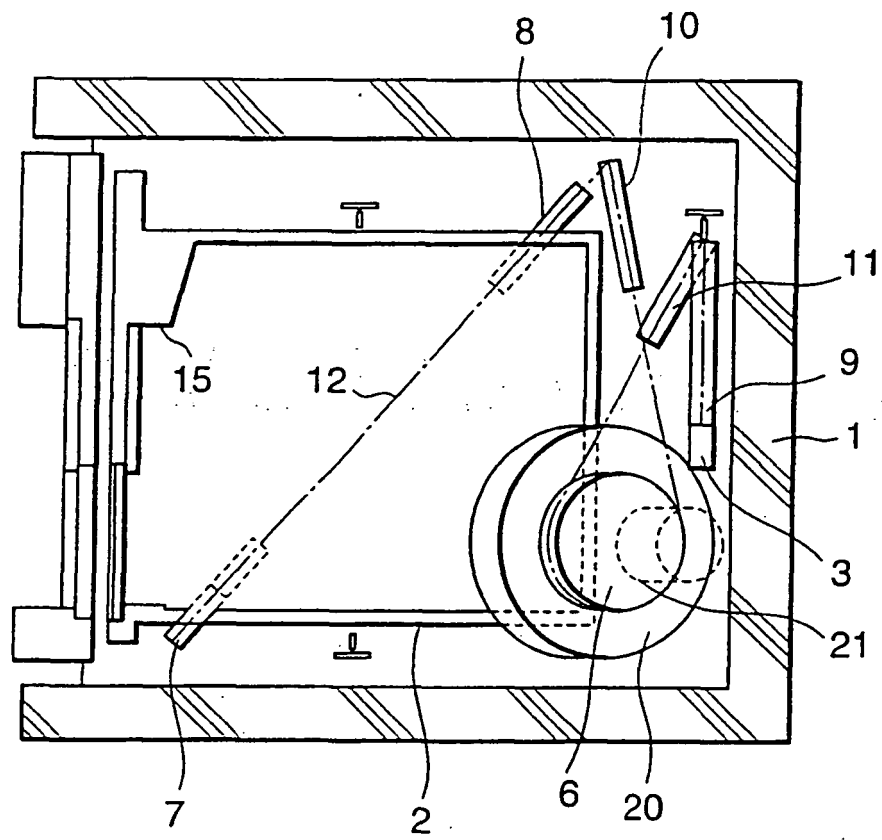



FIG. 9

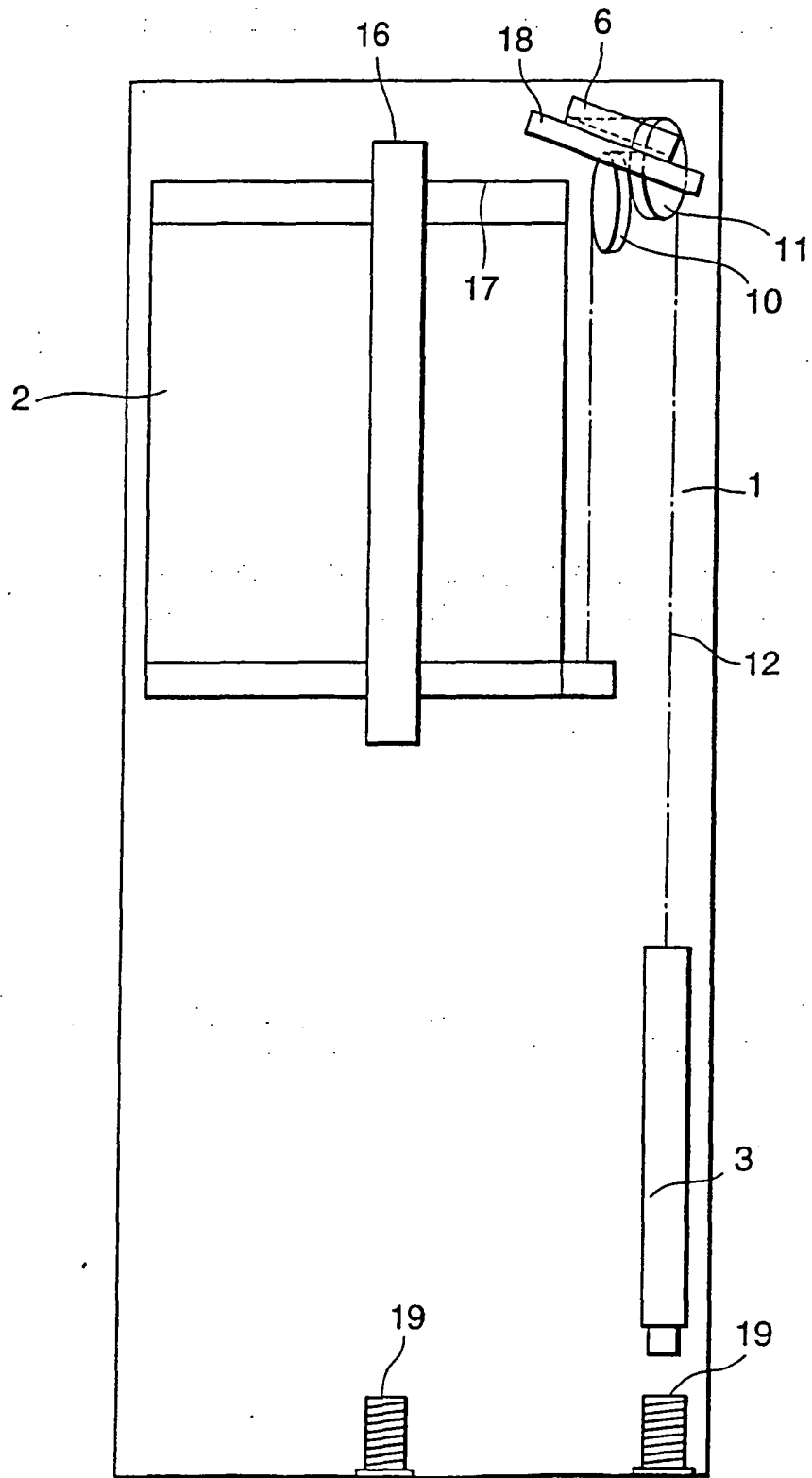

FIG. 10

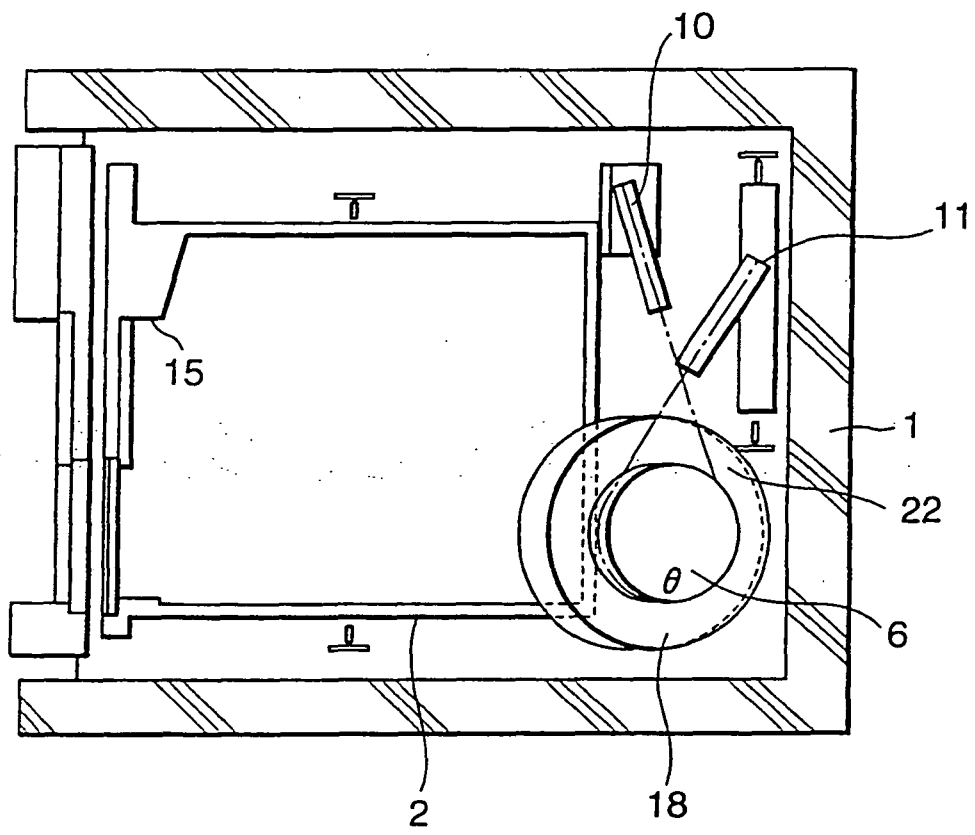

FIG. 11

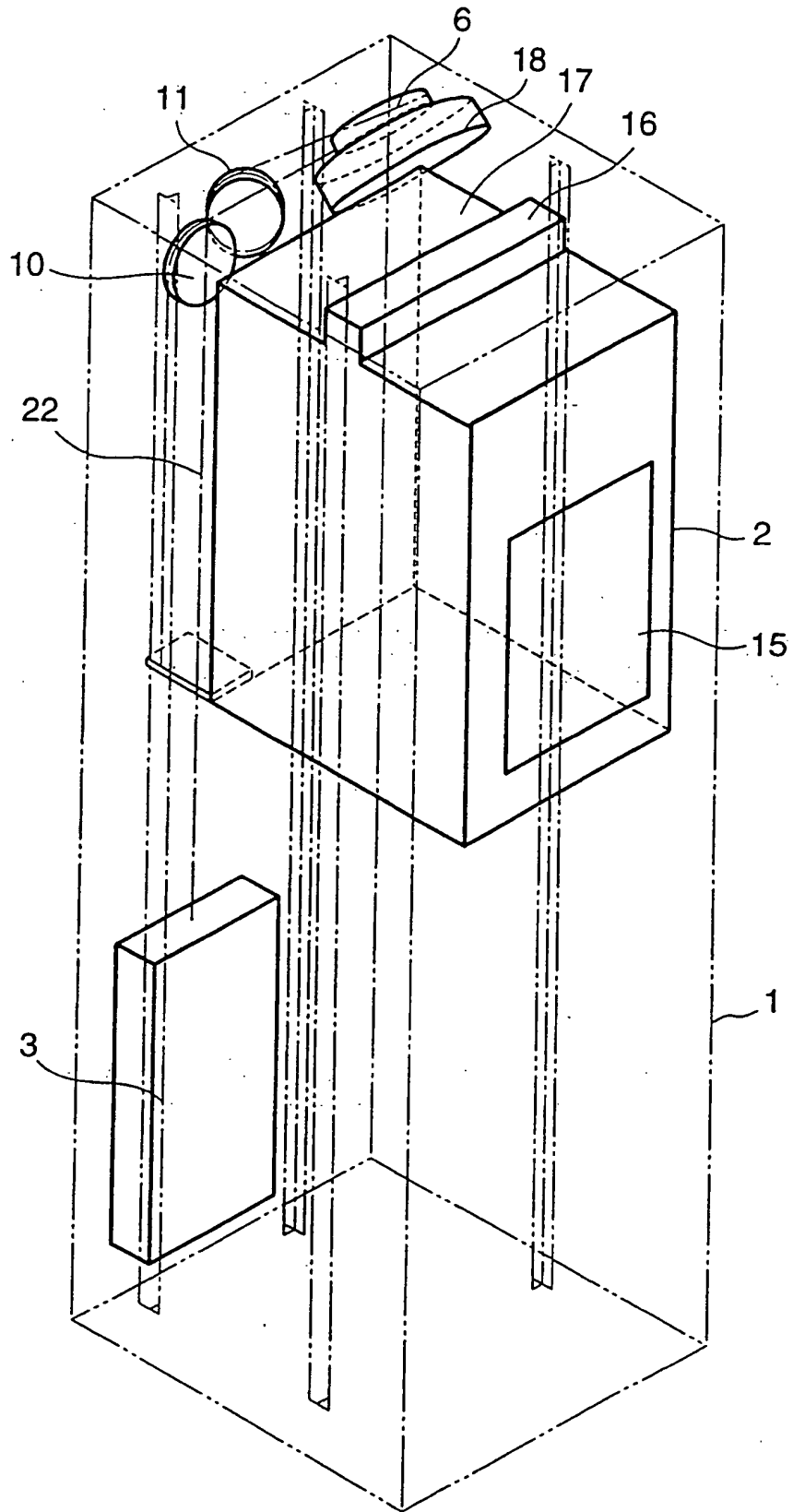

FIG. 12

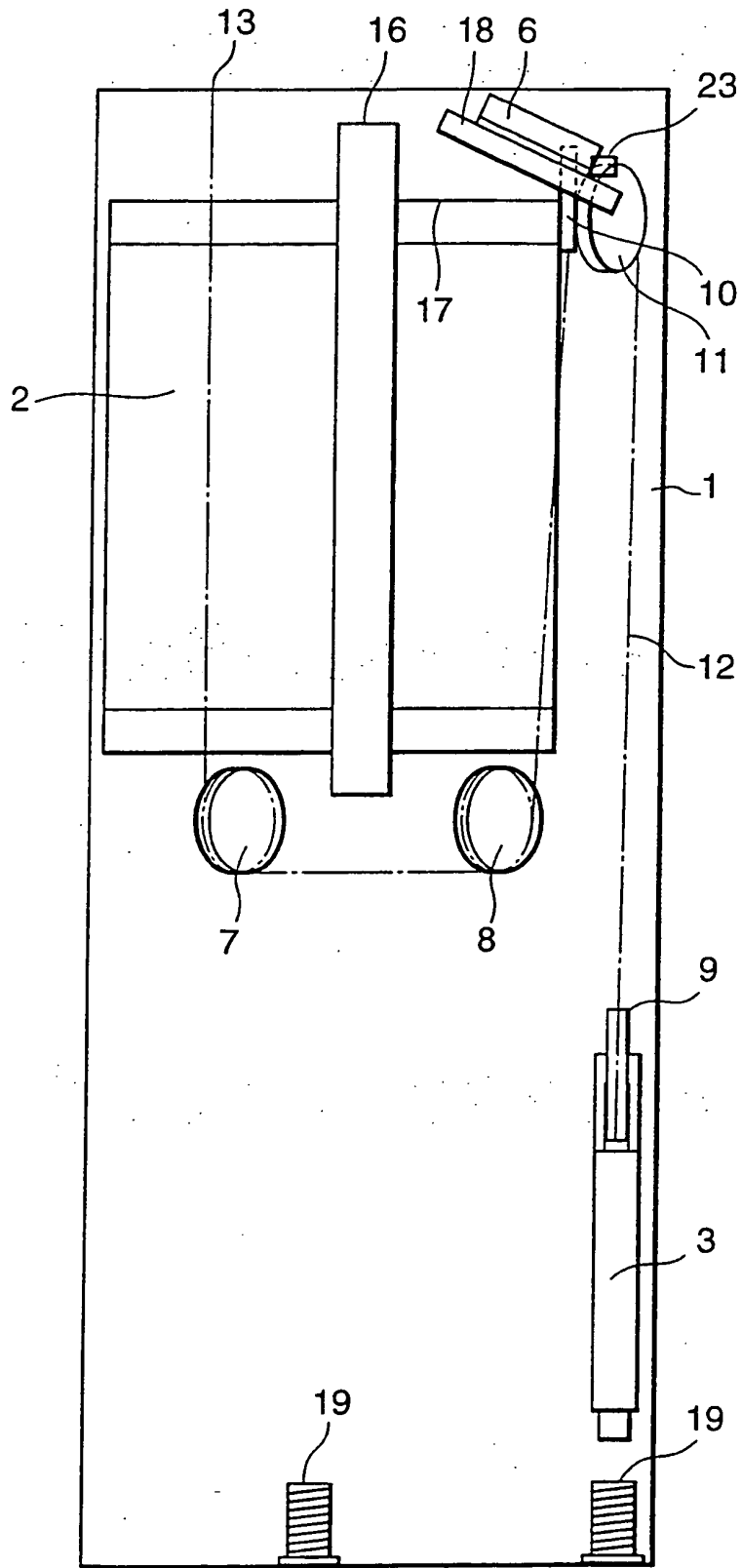



FIG. 14

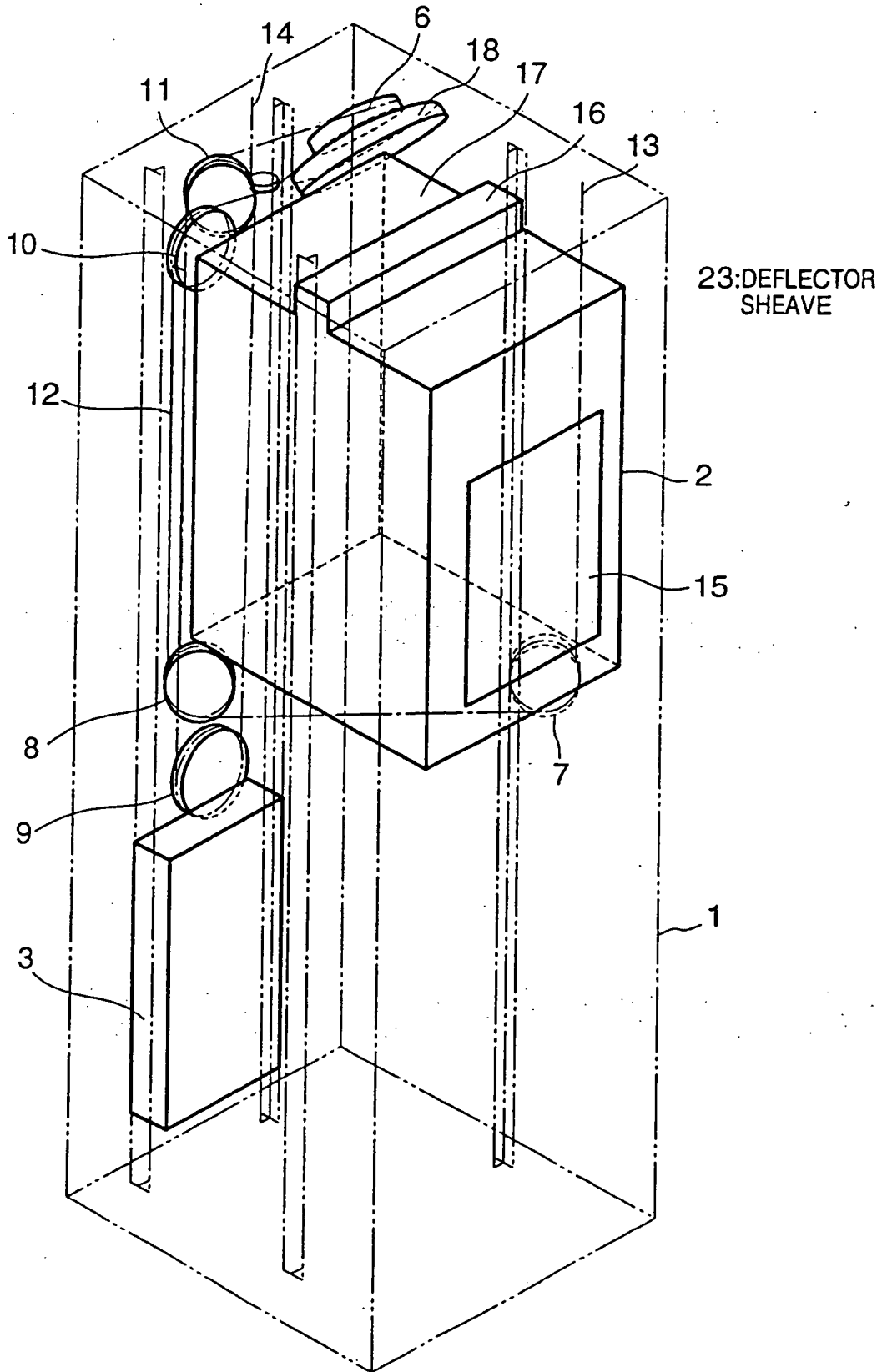

FIG. 15

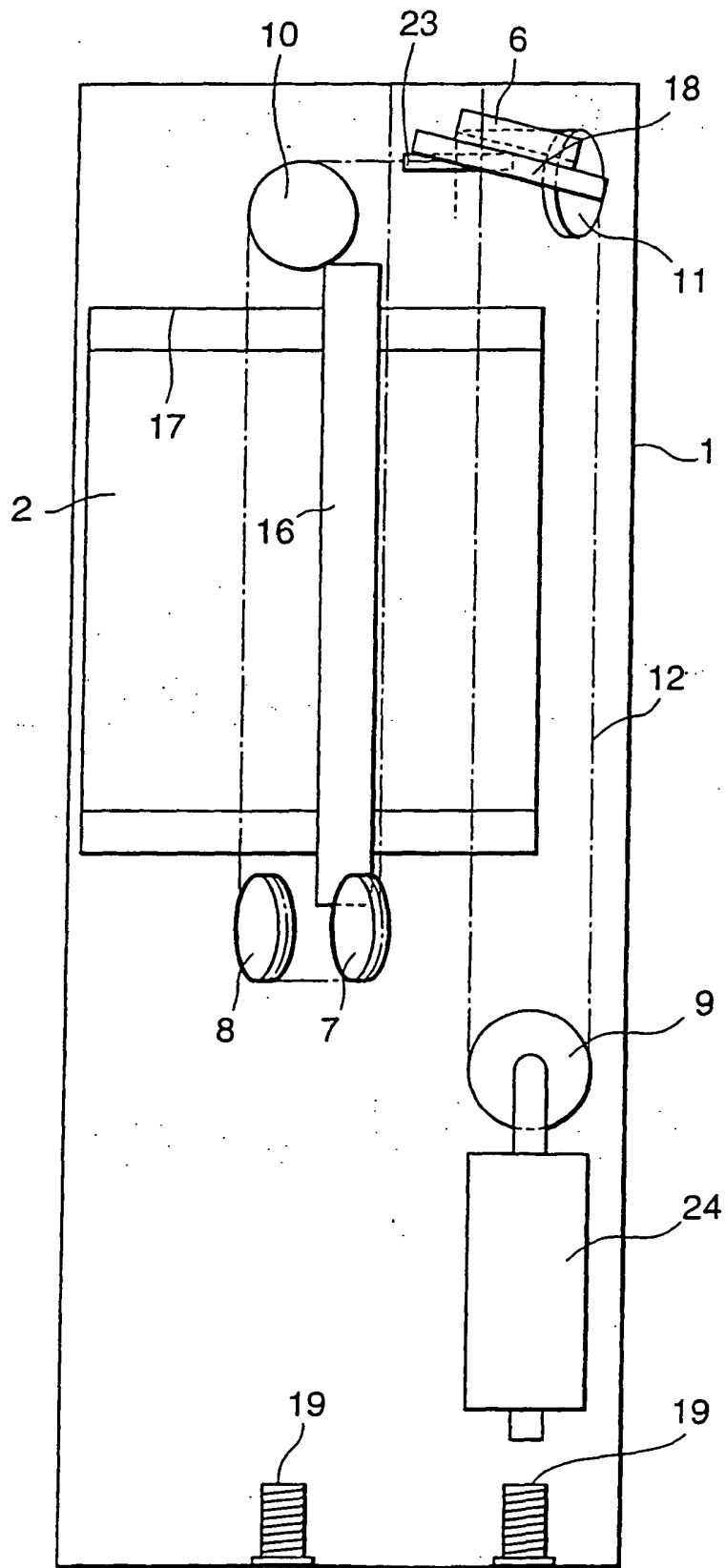

FIG. 16

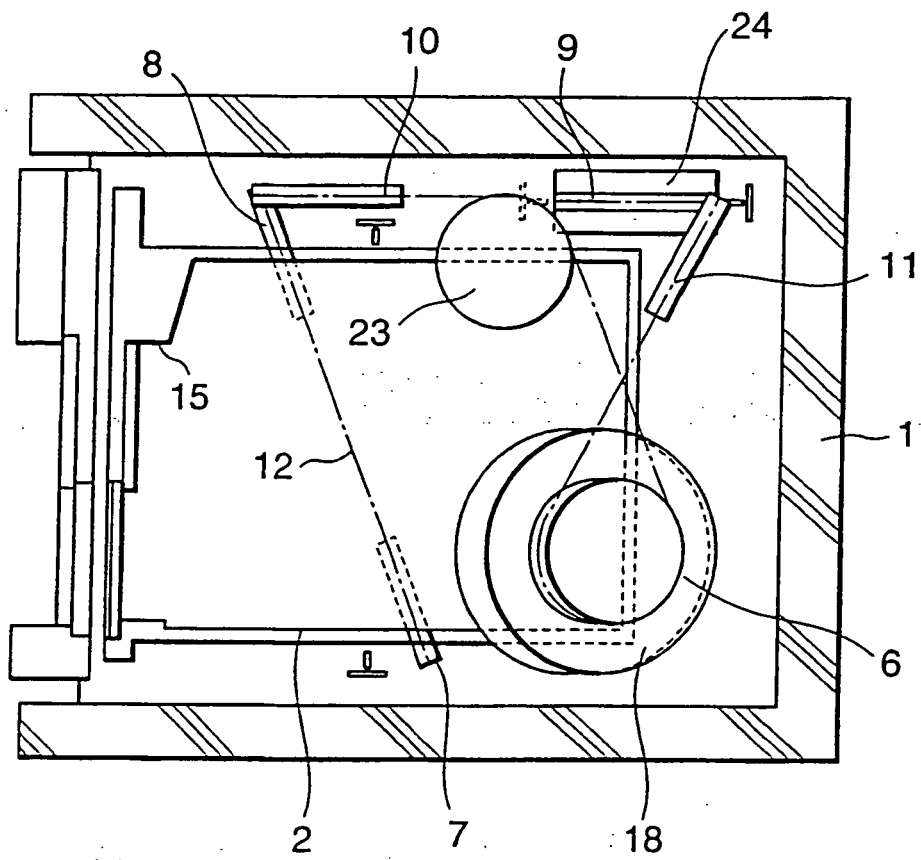

FIG. 17

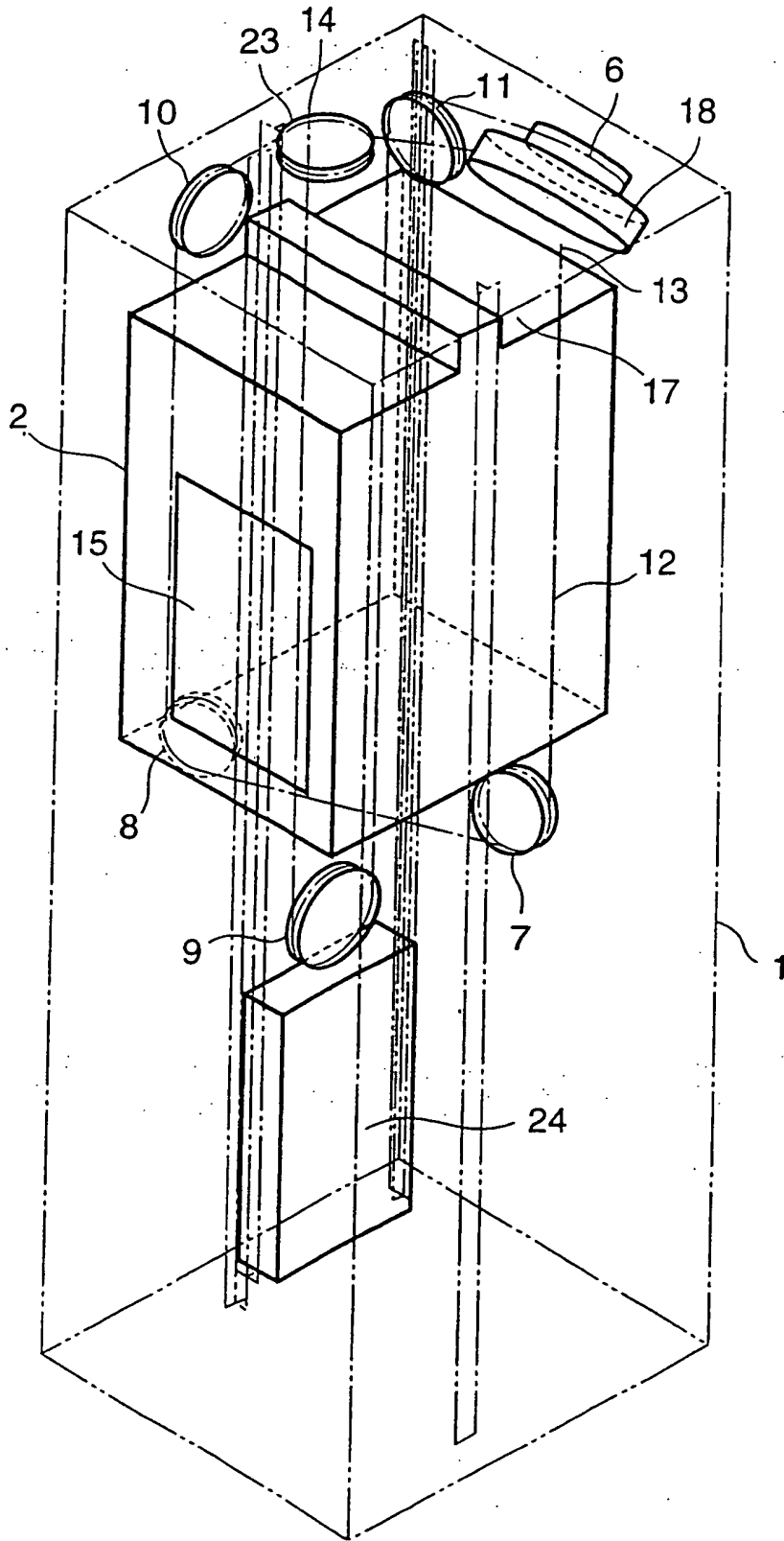

FIG. 18

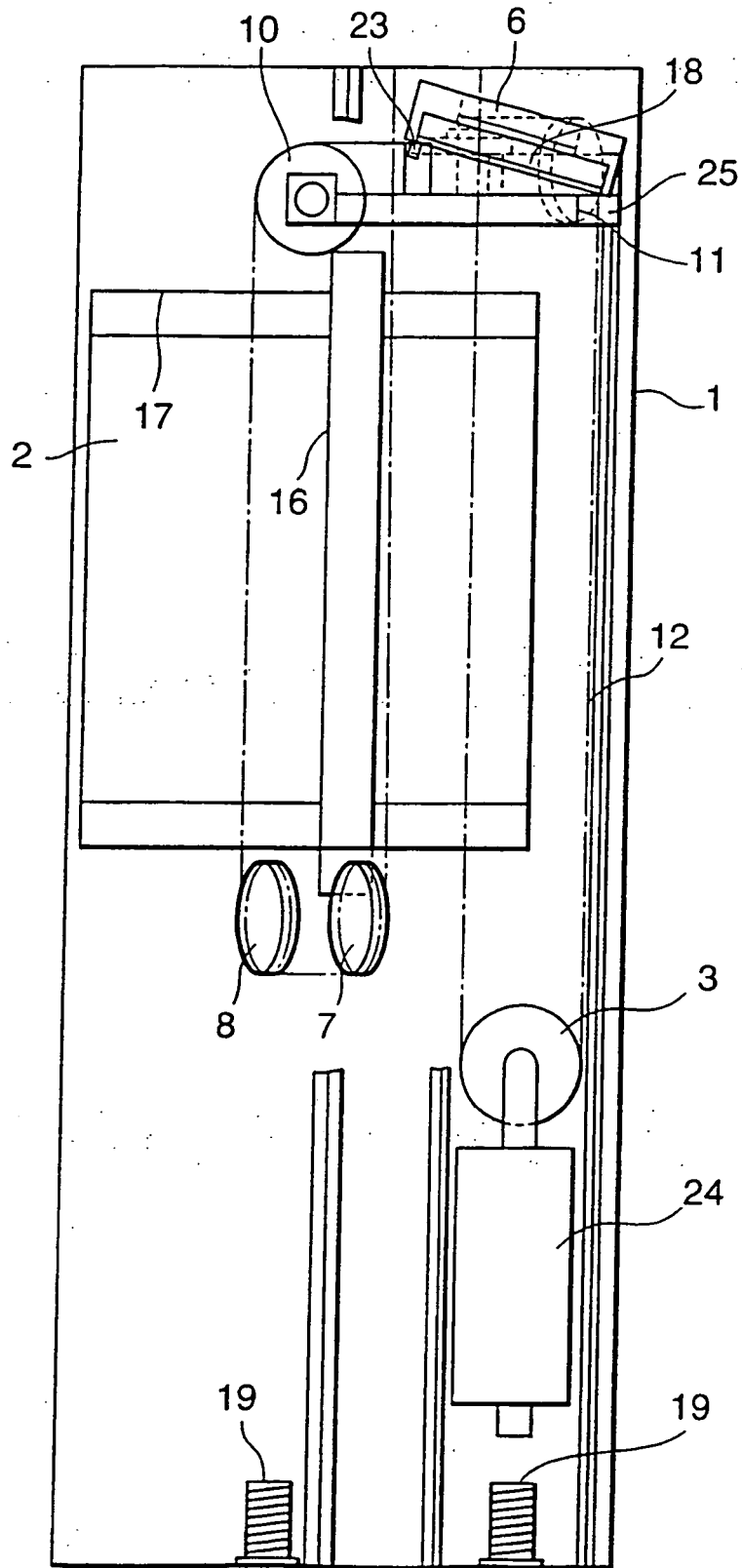

FIG. 19

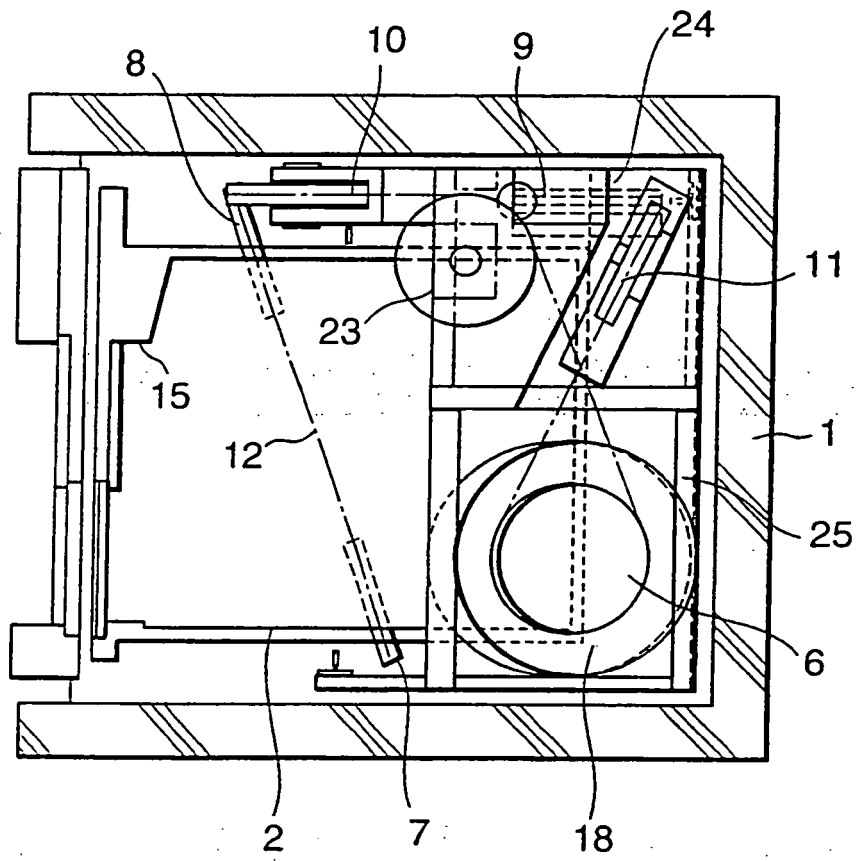
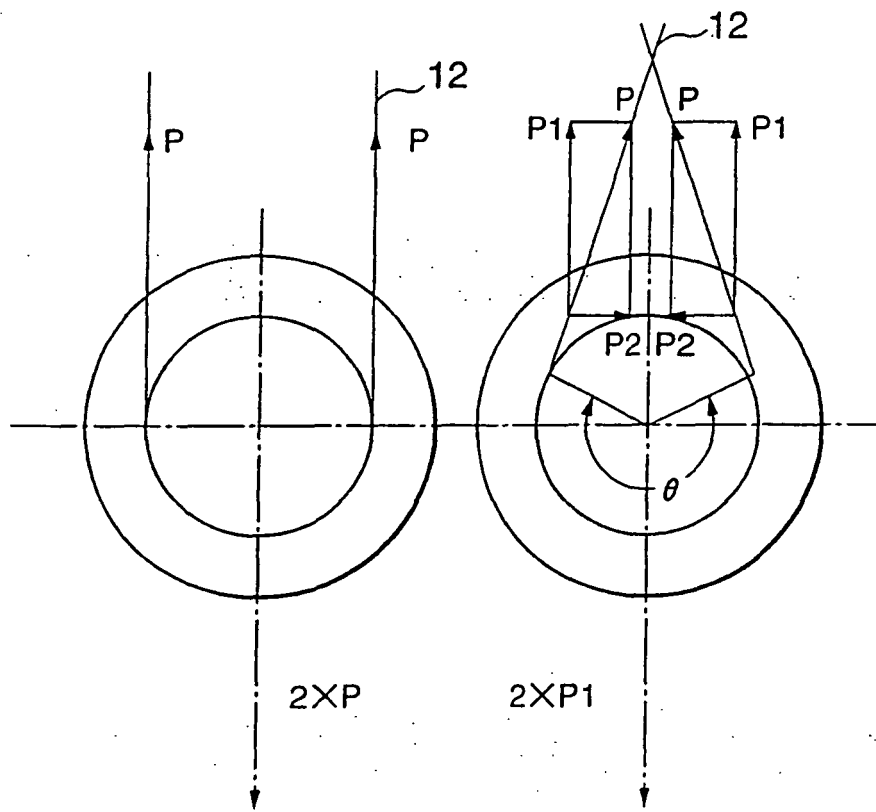

FIG. 20



AN AXIAL FORCE =  $2XP$  > AN AXIAL FORCE =  $2XP1$

FIG. 21

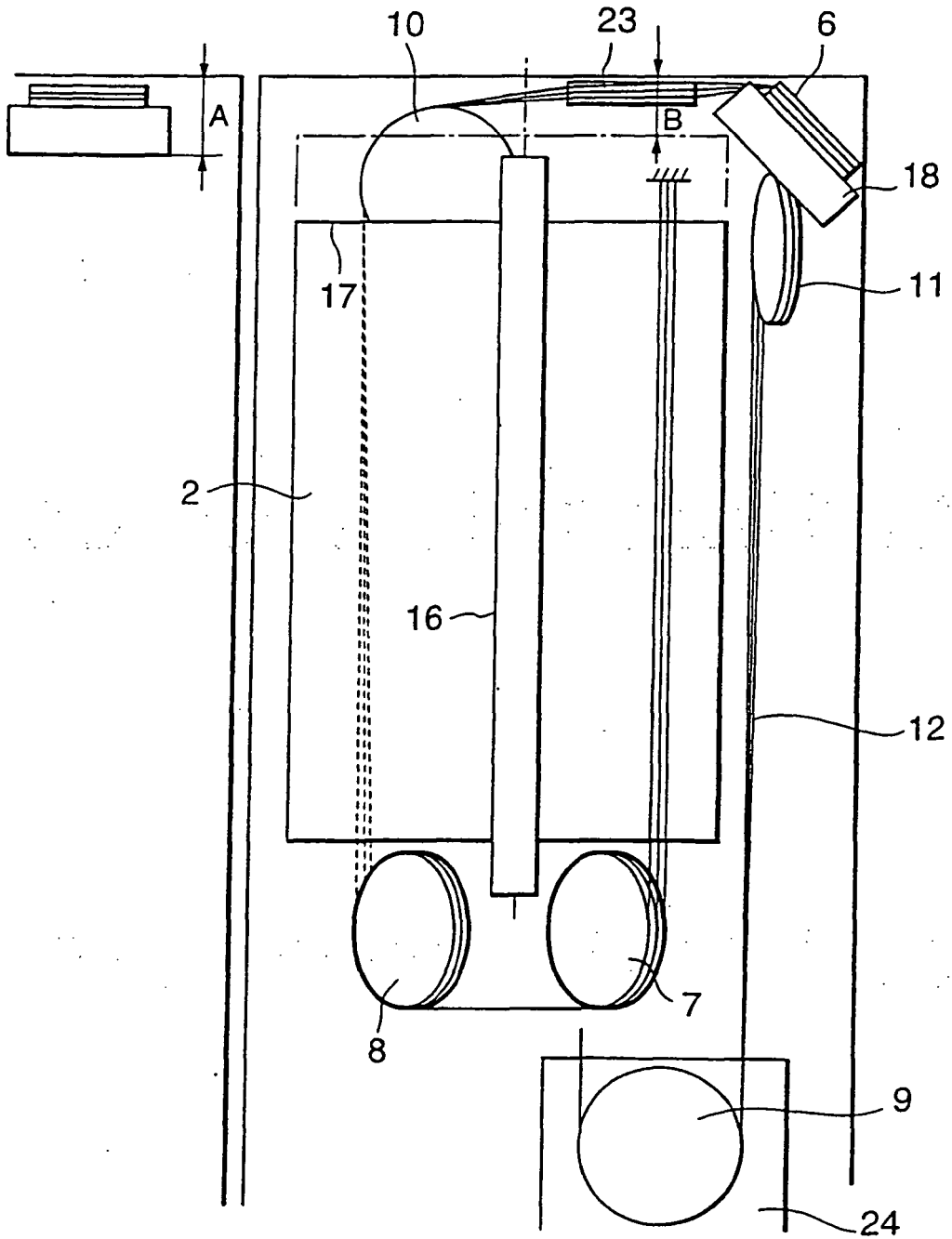

FIG. 22

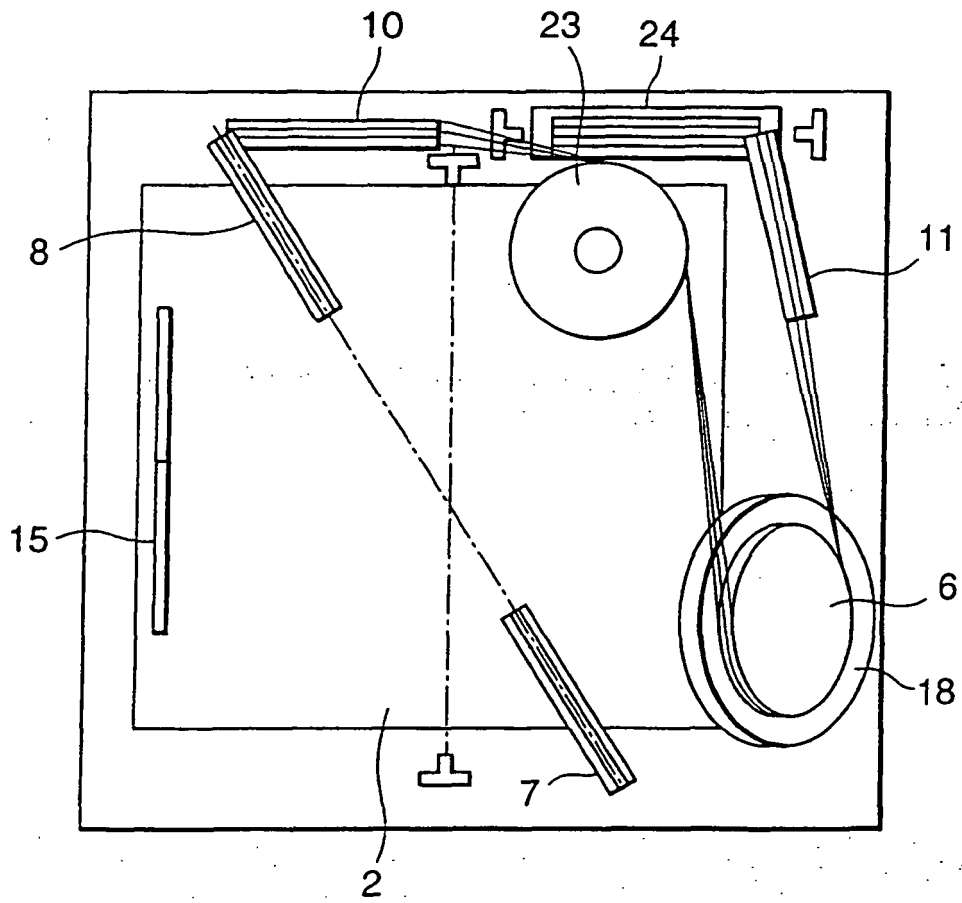

FIG. 23

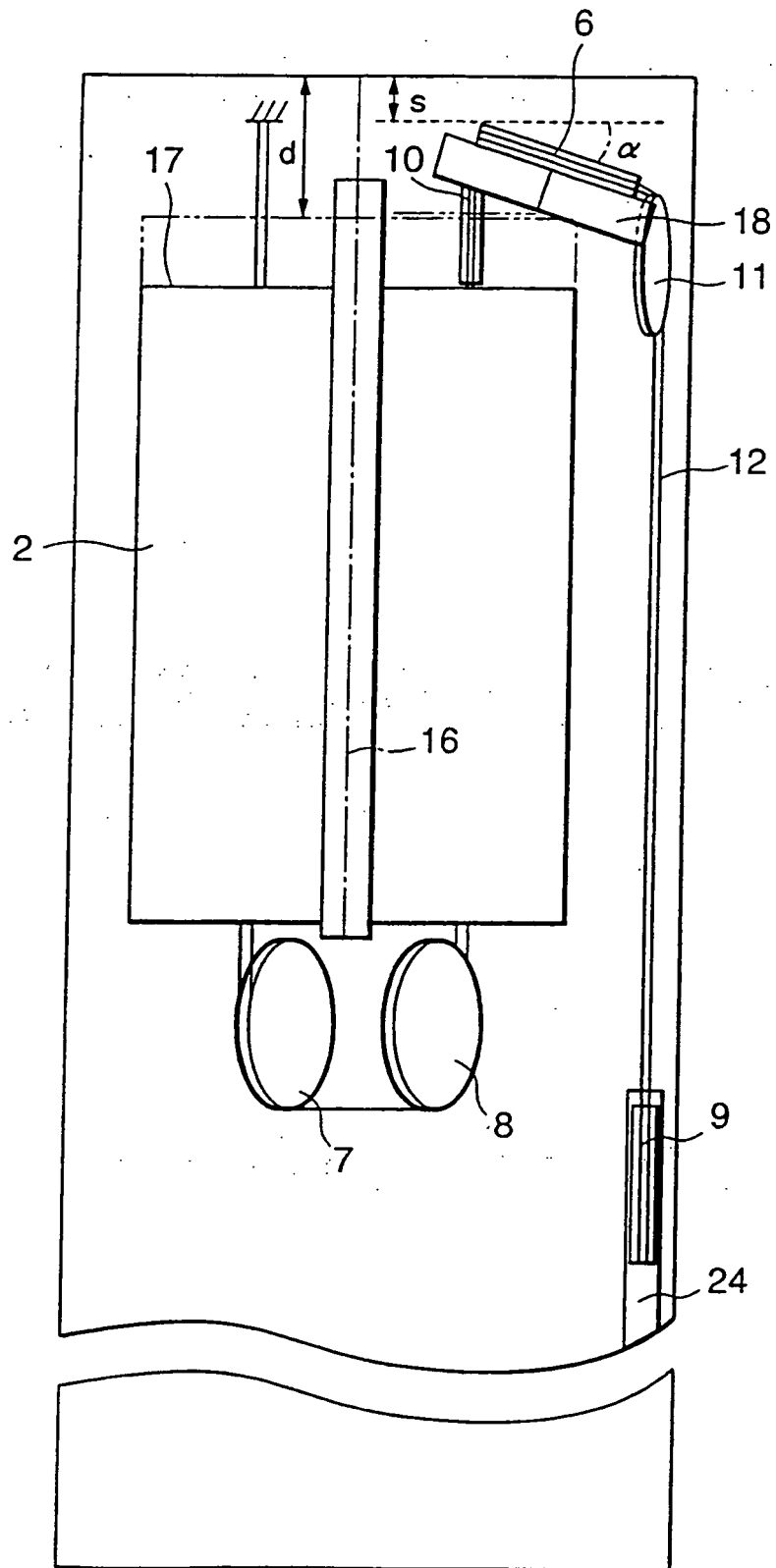

FIG. 24

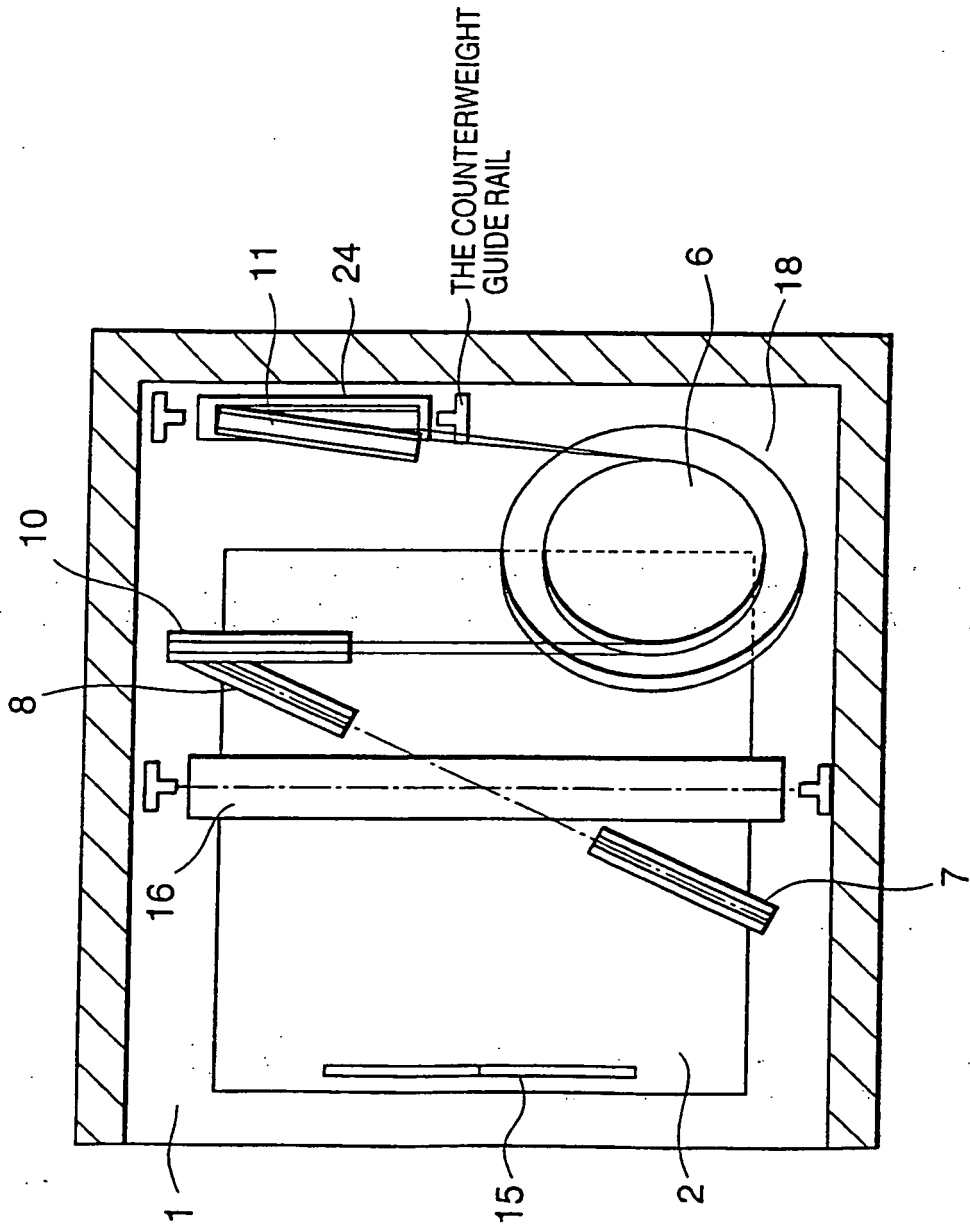

FIG. 25A

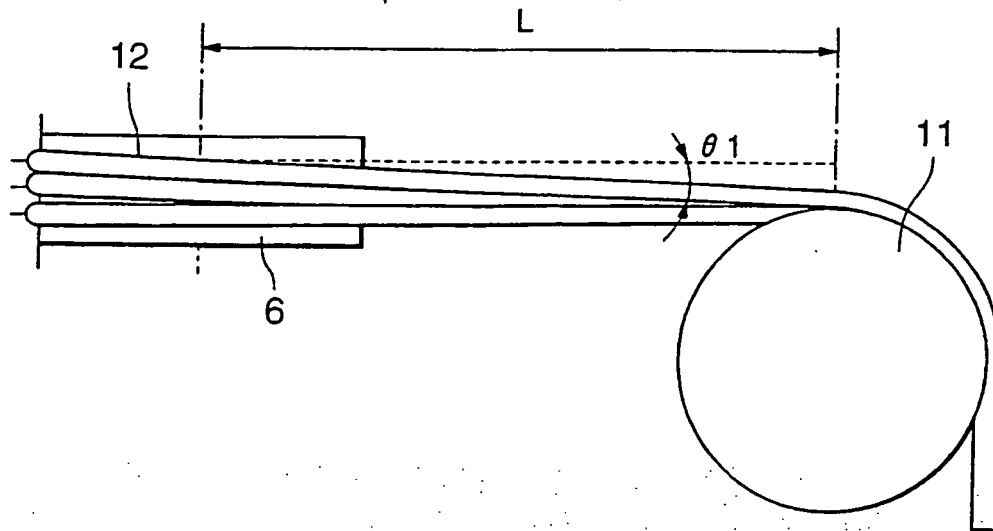

FIG. 25B

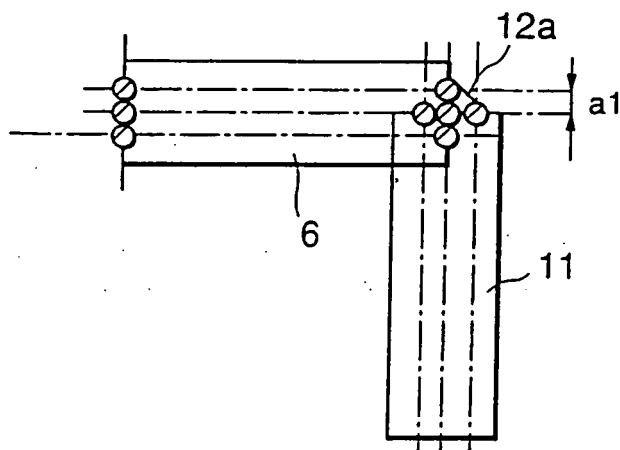

FIG. 26

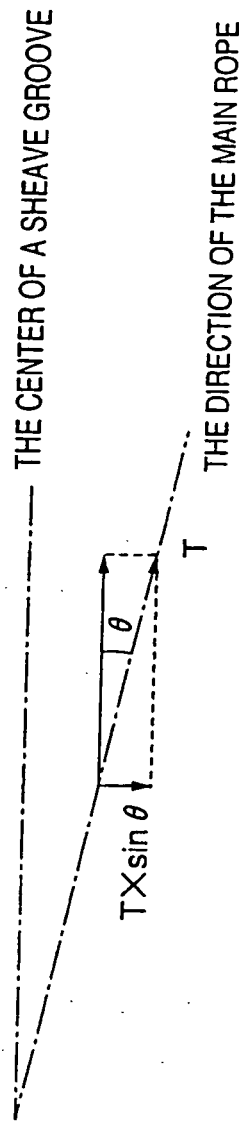

FIG. 27A

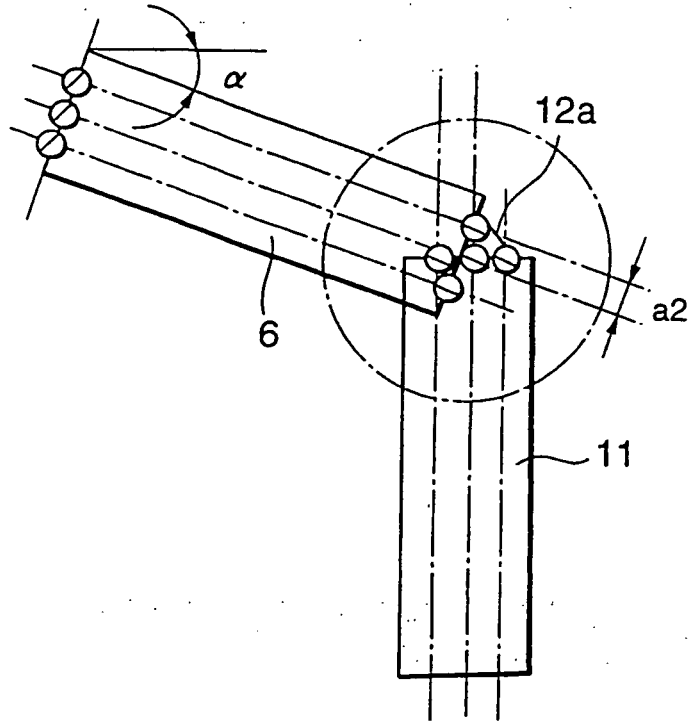

FIG. 27B

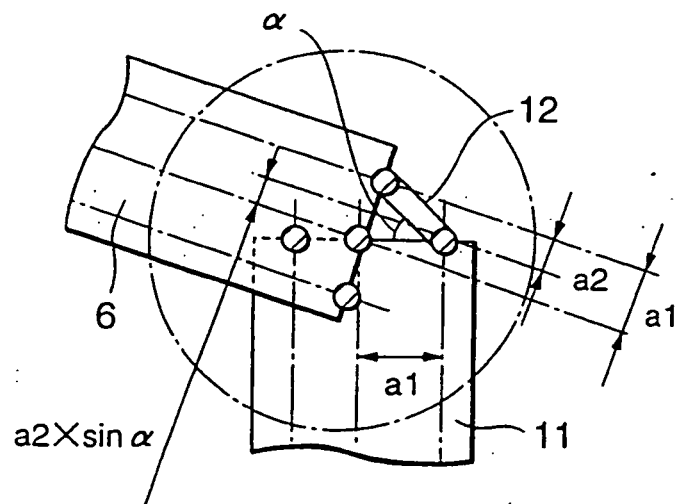

FIG. 28

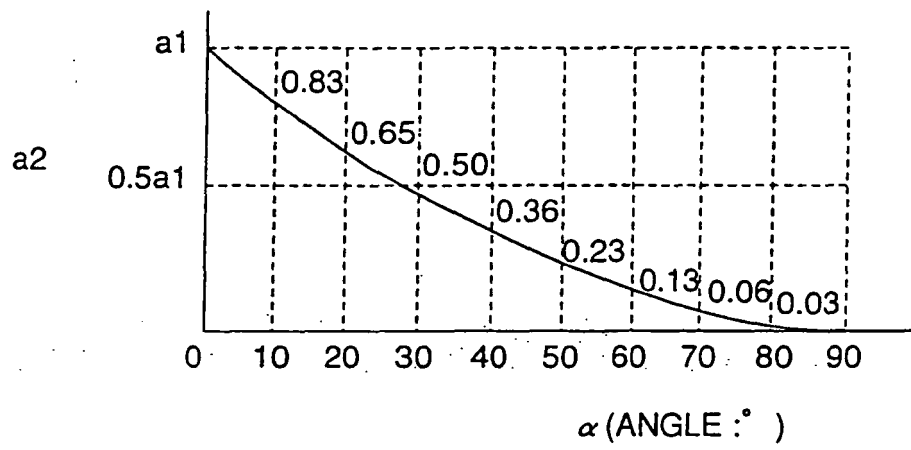

FIG. 29

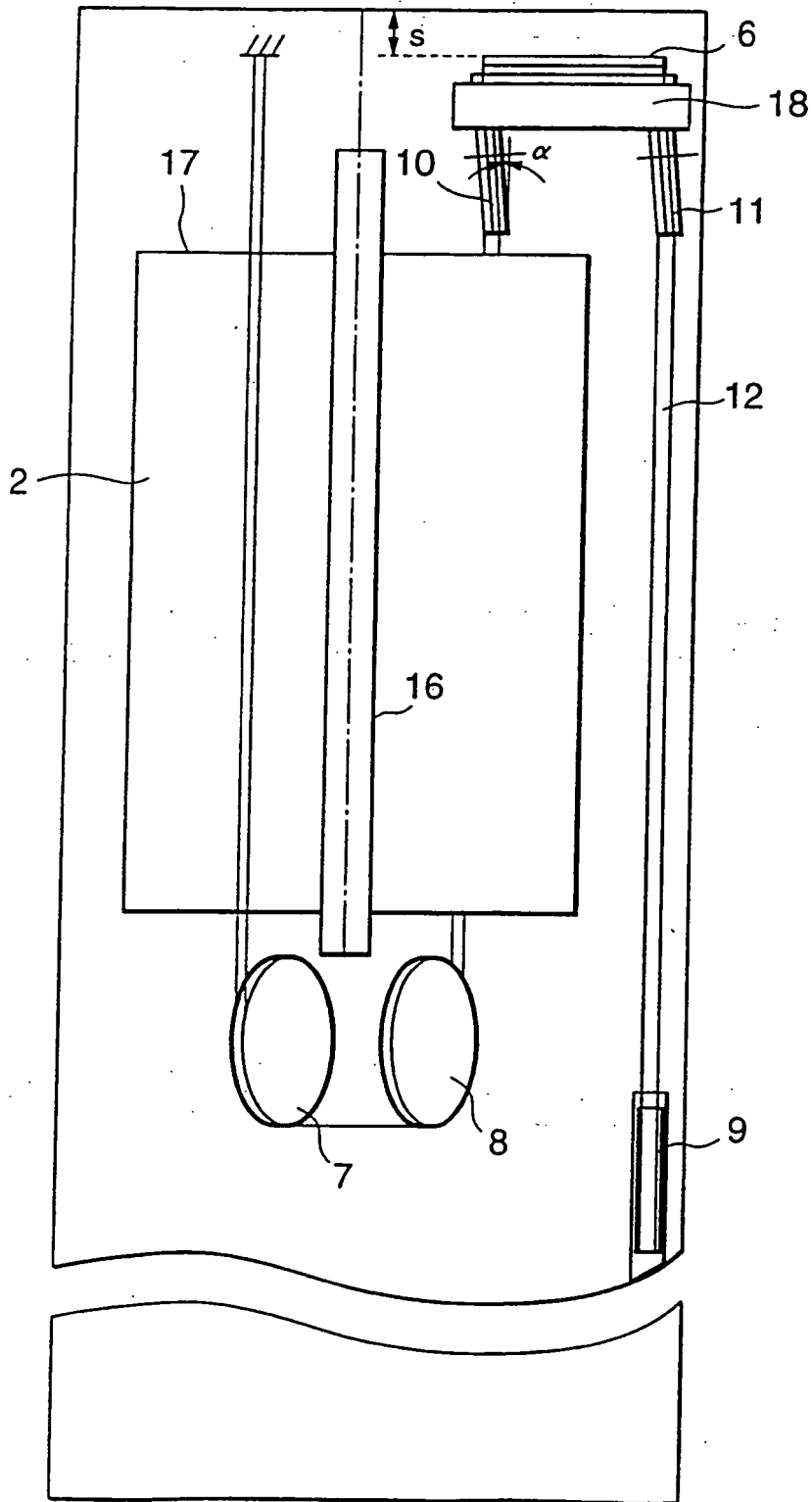

FIG. 30

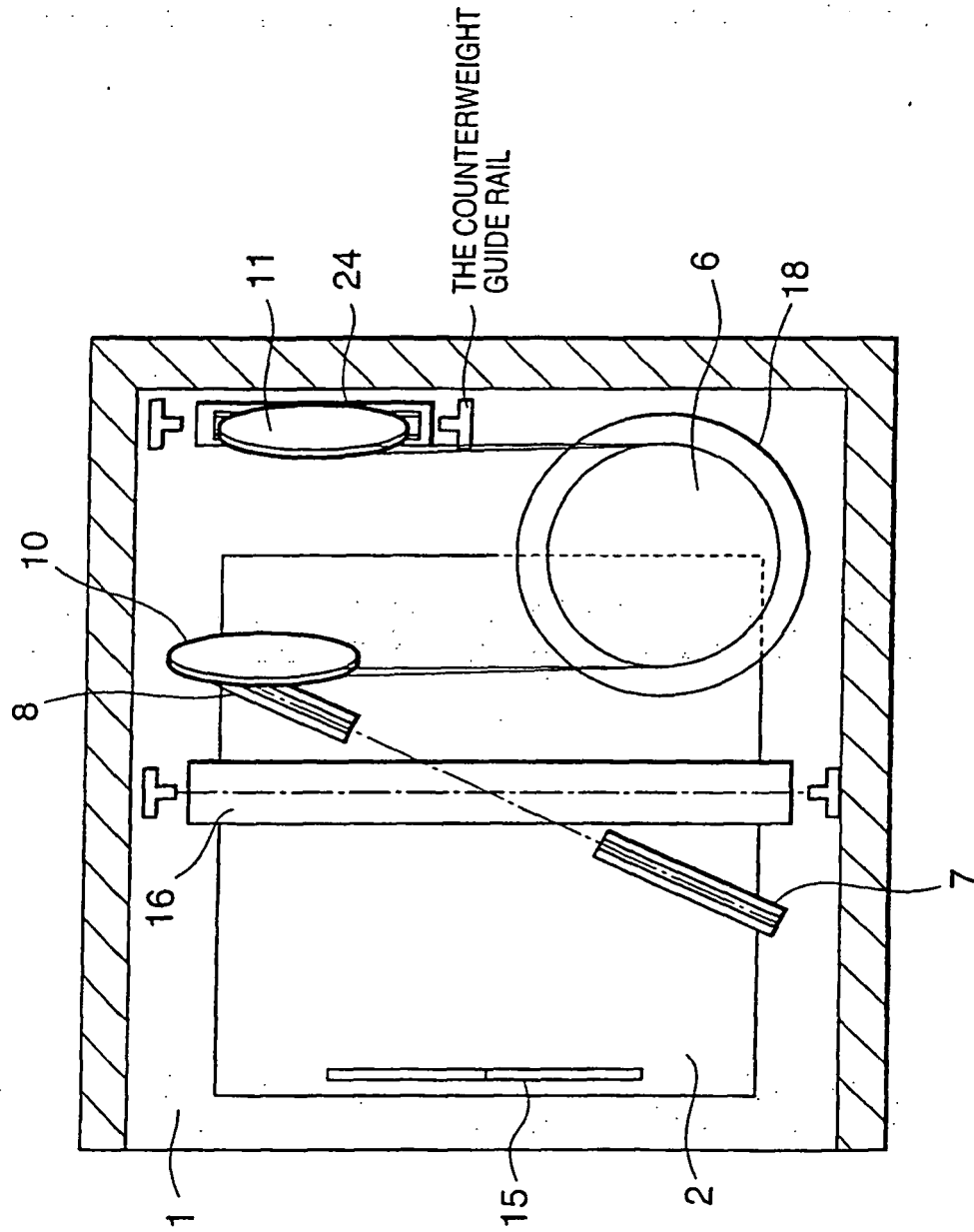

FIG. 31

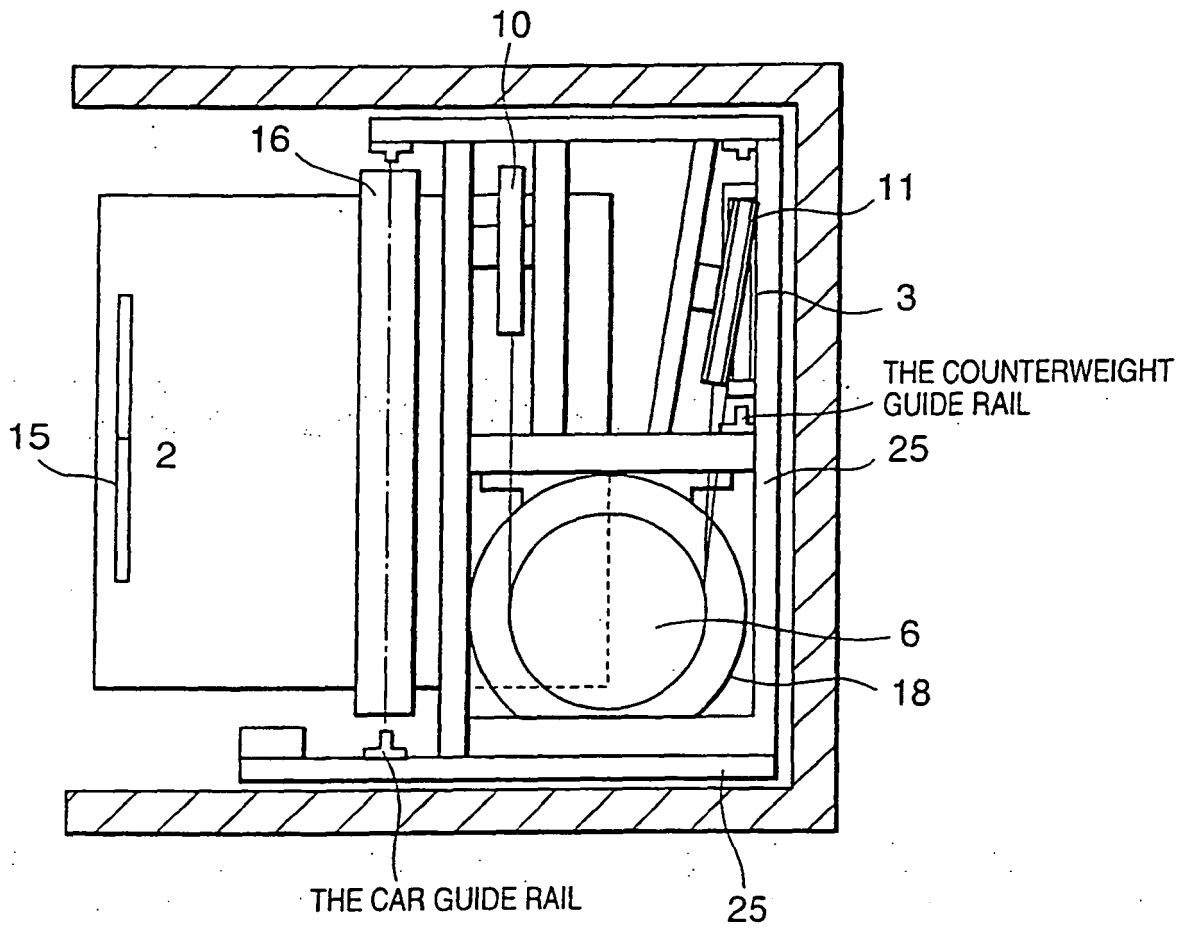

FIG. 32

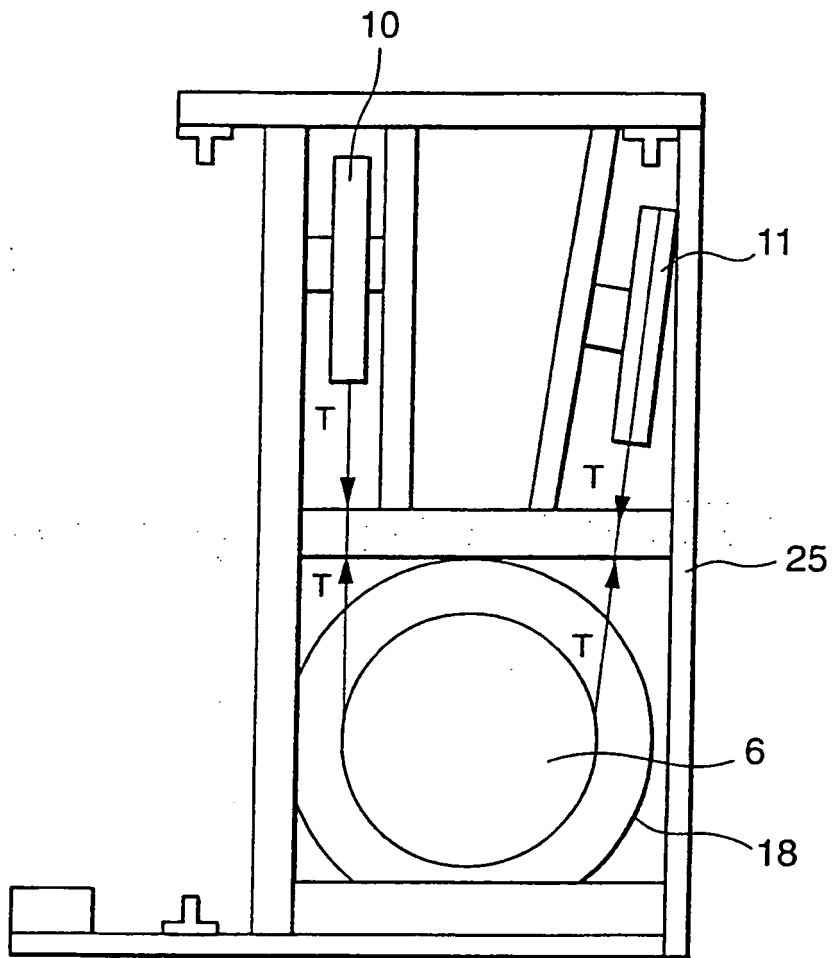

FIG. 33

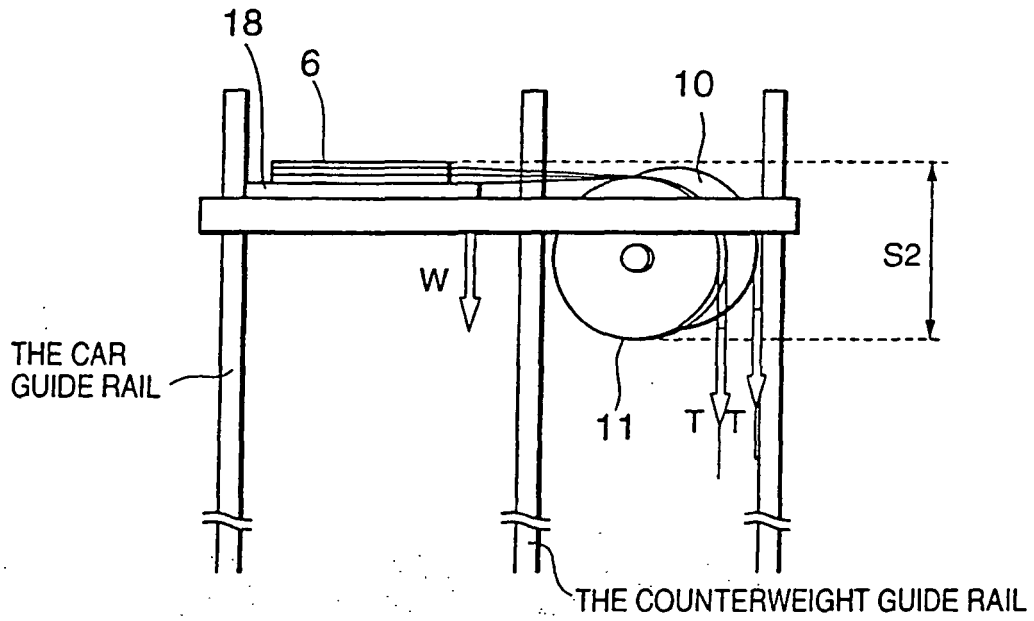

FIG. 34

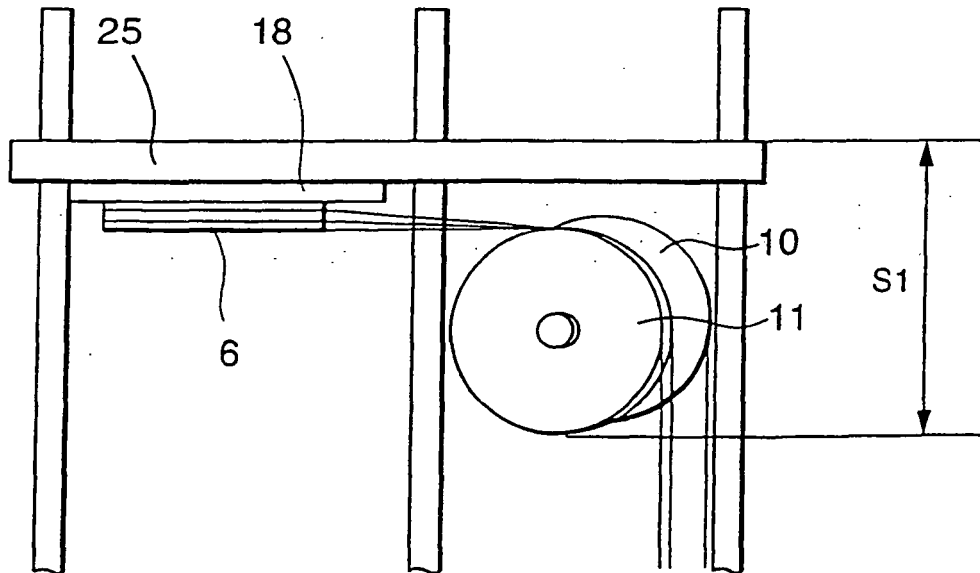

FIG. 35

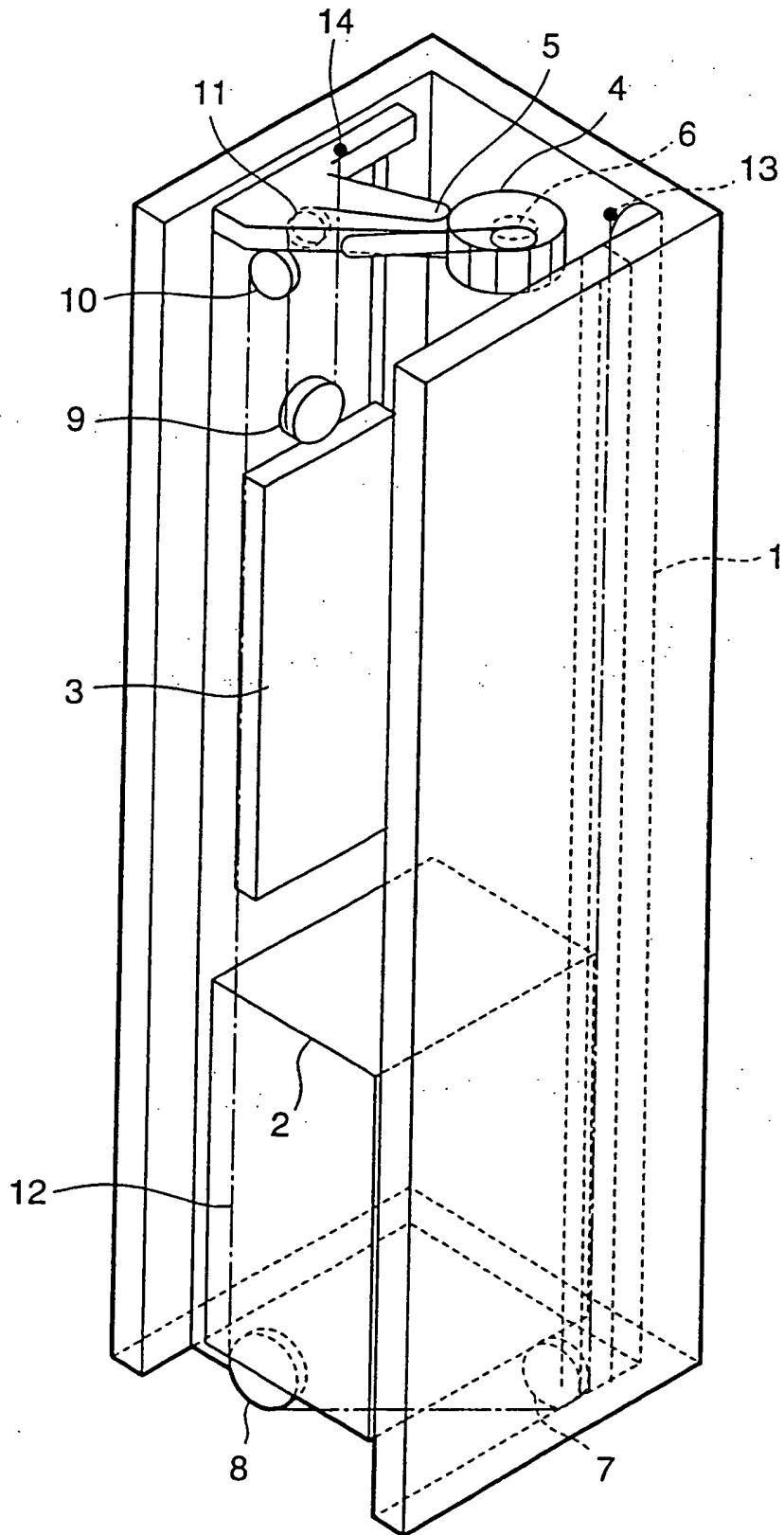
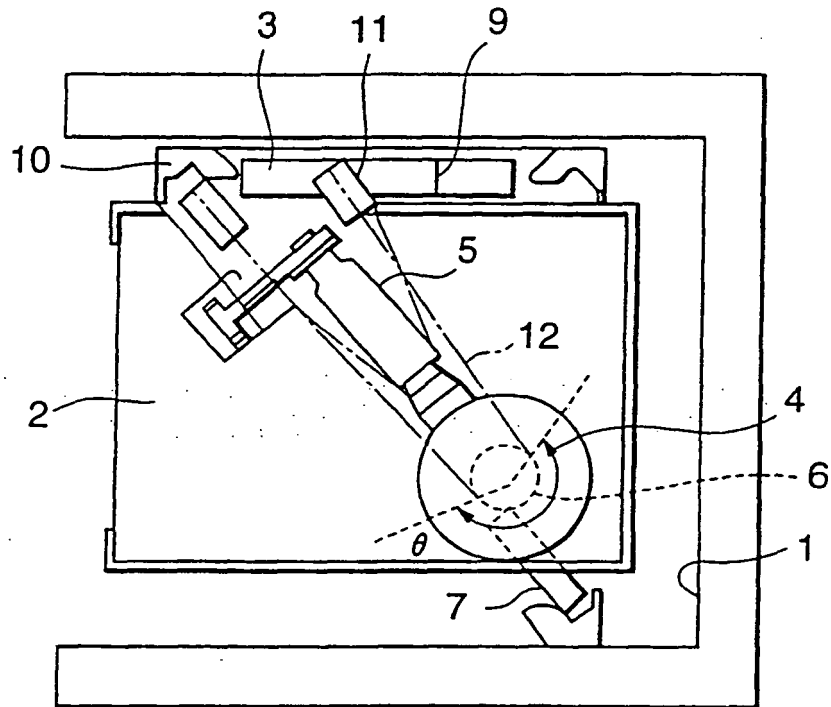

FIG. 36



**REFERENCES CITED IN THE DESCRIPTION**

*This list of references cited by the applicant is for the reader's convenience only. It does not form part of the European patent document. Even though great care has been taken in compiling the references, errors or omissions cannot be excluded and the EPO disclaims all liability in this regard.*

**Patent documents cited in the description**

- JP 10139321 A [0002]
- EP 0841283 A [0002]