

(12) PATENT
(19) AUSTRALIAN PATENT OFFICE

(11) Application No. AU 199535239 B2
(10) Patent No. 701594

(54) Title
Data transmission method in a TDMA mobile communication system

(51)⁶ International Patent Classification(s)
H04Q 007/22

(21) Application No: **199535239** (22) Application Date: **1995 .09 .26**

(87) WIPO No: **WO96/10320**

(30) Priority Data

(31) Number	(32) Date	(33) Country
944487	1994 .09 .27	FI

(43) Publication Date : **1996 .04 .19**

(43) Publication Journal Date : **1996 .06 .06**

(44) Accepted Journal Date : **1999 .02 .04**

(71) Applicant(s)
Nokia Telecommunications Oy

(72) Inventor(s)
Jari Hamalainen; Jari Vainikka; Zhi-Chun Honkasalo; Harri Jokinen; Harri Posti

(74) Agent/Attorney
SPRUSON FERGUSON

(56) Related Art
EP 332818
CA 2112762
US 4949395

OPI DATE 19/04/96 APPLN. ID 35239/95
 AOJP DATE 06/06/96 PCT NUMBER PCT/FI95/00526



AU9535239

IN

(51) International Patent Classification ⁶ : H04Q 7/22	A2	(11) International Publication Number: WO 96/10320
		(43) International Publication Date: 4 April 1996 (04.04.96)
(21) International Application Number: PCT/FI95/00526	(81) Designated States: AM, AT, AU, BB, BG, BR, BY, CA, CH, CN, CZ, DE, DK, EE, ES, FI, GB, GE, HU, IS, JP, KE, KG, KP, KR, KZ, LK, LR, LT, LU, LV, MD, MG, MK, MN, MW, MX, NO, NZ, PL, PT, RO, RU, SD, SE, SG, SI, SK, TJ, TM, TT, UA, UG, US, UZ, VN, European patent (AT, BE, CH, DE, DK, ES, FR, GB, GR, IE, IT, LU, MC, NL, PT, SE), OAPI patent (BF, BJ, CF, CG, CI, CM, GA, GN, ML, MR, NE, SN, TD, TG), ARIPO patent (KE, MW, SD, SZ, UG).	
(22) International Filing Date: 26 September 1995 (26.09.95)	Published Without international search report and to be republished upon receipt of that report.	
(30) Priority Data: 944487 27 September 1994 (27.09.94) FI		
(71) Applicant (for all designated States except US): NOKIA TELECOMMUNICATIONS OY [FI/FI]; Mattien puisto 1, FIN-02600 Espoo (FI); <i>Upseerinkatu 1 FIN-02600 Espoo Finland</i>		
(72) Inventors; and		
(75) Inventors/Applicants (for US only): HÄMÄLÄINEN, Jari [FI/FI]; Matti Tapionkatu 1 F 17, FIN-33720 Tampere (FI). VAINIKKA, Jari [FI/FI]; Neilikkuja 5 B, FIN-01300 Vantaa (FI). HONKASALO, Zhi-Chun [GB/FI]; Haravakujä 12, FIN-01660 Vantaa (FI). JOKINEN, Harri [FI/FI]; Vähähieidentie 450, FIN-25370 Hiisi (FI). POSTI, Harri [FI/FI]; Rantakatu 14 B 17, FIN-90120 Oulu (FI).		
(74) Agent: OY KOLSTER AB; Iso Roobertinkatu 23, P.O. Box 148, FIN-00121 Helsinki (FI).		

521
10/10
4



(54) Title: DATA TRANSMISSION METHOD IN A TDMA MOBILE COMMUNICATION SYSTEM

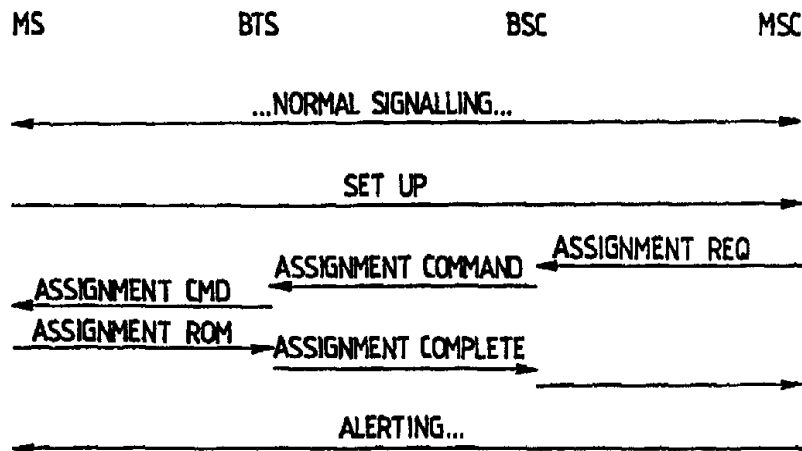

(57) Abstract

The invention relates to a data transmission method in a TDMA mobile communication system. In a mobile communication system employing a so-called multi-slot access technique, one or more time-slots may be allocated to a mobile station for data transmission at the data transfer rate required by an application using the mobile station. In the invention, upon establishing a data call, the mobile station (MS) indicates the mobile communication network (BTS, BSC, MSC) the minimum and the maximum requirements for the user data transfer rate (Set Up). The mobile communication network assigns the mobile station (MS) for a data call a channel configuration, depending on the network resources currently available in the mobile communication network and enabling a data transfer rate which is between the minimum requirement and the maximum requirement.

Data transmission method in a TDMA mobile communication system

Field of the Invention

5 The invention relates to a method for data transmission in a time division multiple access (TDMA) mobile communication system, comprising the step of assigning one or more time-slots to a mobile station for data transmission depending on the data transfer rate
10 required by an application using the mobile station.

Background of the Invention

 In mobile telecommunication systems of the time division multiple access (TDMA) type, communication takes place on the radio path in successive TDMA frames, each of which consists of several time-slots. In each
15 time-slot, a short information packet is sent in form of a radio frequency burst which has a finite duration and which consists of a set of modulated bits. The time-slots are mainly used for conveying control channels and
20 traffic channels. On the traffic channels, speech and data are transmitted. On the control channels, signalling between a base station and mobile subscriber stations is carried out. An example of a TDMA radio system is the Pan-European mobile communication system GSM
25 (Global System for Mobile Communications).

 For communication in conventional TDMA systems, each mobile station is assigned one channel time-slot for data or speech transmission. Thus, the GSM system, for instance, may have up to eight parallel connections
30 to different mobile stations on a same carrier frequency. The maximum data transfer rate on one traffic channel is restricted to a relatively low level depending on the available channel bandwidth as well as the channel coding and error correction used in the transmission.
35 In the GSM system, for instance, the user rate is

9.6 kbit/s or 12 kbit/s. In addition, in the GSM system a so-called half-rate (max. 4.8 kbit/s) traffic channel may be chosen for low speech coding rates. A half-rate channel is established when a mobile station communicates in a time-slot only in every second time-slot, i.e. at half-rate. A second mobile station communicates in every second time-slot of the same frame. The capacity of the system in terms of the number of subscribers may thus be doubled, in other words, up to 16 mobile stations may communicate simultaneously on the same carrier frequency.

In the last few years, the need for high-speed data services in mobile communication networks has remarkably increased. Data transfer rates of at least 64 kbit/s would be required for utilizing ISDN (Integrated Services Digital Network) circuit switched digital data services, for example. Data services of the public network PSTN, such as modems and telefax terminals of class G3, require higher transfer rates, such as 14.4 kbit/s. One of the growing areas of mobile data transfer that requires higher transfer rates than 9.6 kbit/s is the mobile video service. Services of this kind include e.g. security control by cameras, and video databases. The minimum data transfer rate in video transfer may be, for instance, 16 or 32 kbit/s.

The data transfer rates of the present mobile communication networks are not, however, adequate to satisfy these new needs.

One way to solve the problem is to use multiple TDMA time-slots for communication with a mobile station. In this way, one mobile station may transmit and receive data at higher data transfer rates by multiplexing the data to multiple time-slots (traffic channels). This is termed as multi-slot access technique.

When multiple time-slots are used for communication with one mobile station, problems arise if a sufficient number of traffic channels is not available. This may occur in the cell set-up phase or in a handover. Handover refers to switching the mobile station from one channel onto another channel of the same cell or an adjacent cell during an ongoing call. A problem arises if the mobile station is operating at a high data transfer rate, and the new cell can not provide after the handover a data transfer rate as high as that of the previous cell. One solution would be to interrupt the connection if the quality i.e. the data transfer rate of the data transfer service is not adequate in the call set-up or handover, or after the handover. However, this solution is not acceptable.

It is an object of the present invention to ameliorate one or more disadvantages of the prior art.

Summary of the Invention

Therefore, the invention discloses a data method for data transmission in a time division multiple access (TDMA) mobile communication system, in which one or more time-slots may be allocated to a mobile station for data transmission, the method comprising the steps of:

- indicating by the mobile station, upon setting up a data call, to a mobile communication network a desired level of service for a user data transfer,
- assigning by the mobile communication network to the mobile station for a data call a channel configuration consisting of one or more time-slots in connection with call set-up or handover, said channel configuration depending on the resources currently available in the mobile communication network, and
- enabling a data channel performance which is within the limits of said desired level of service.

The method further discloses a time division multiple access (TDMA) mobile communication system, in which one or more time-slots may be allocated to a mobile station for data transmission, wherein



the mobile station is arranged to indicate, upon setting up a data call, to the mobile communication network a desired level of service for a user data transfer,

the mobile communication network is arranged to assign the mobile station for a data call a channel configuration consisting of one or more time-slots in connection
5 with call set-up or handover, said channel configuration depending on the resources currently available in the mobile communication network and enabling a data channel performance which is within the limits of said desired level of service.

In the invention, the data transfer rate of a data call is reduced in a mobile communication system employing a so-called multi-slot access technique when a
10 channel configuration that meets the maximum requirements for the user data transfer rate is not available. This may take place during call set-up or handover. The mobile station may start a high-speed data connection by transmitting the serving mobile communication network the minimum and the maximum requirements for the user data transfer rate, in addition to the presently specified parameters used for establishing a
15 data call. These requirements may include the following parameters: the required level of service (data transfer rate) and the desired level of service (date transfer rate). The required level of service determines the data transfer rate the mobile station wishes to be able to use. Simultaneously, the desired transfer rate is the maximum data transfer rate to be allowed for the mobile station. With this parameter, the user of the mobile
20 station may, e.g. call-specifically, in each case choose the most appropriate data transfer service in terms of speed and costs. The

5
10
15
20



required level of service determines the minimum data transfer rate that must be provided for ensuring the continuity of data transfer. If the required data transfer rate cannot be provided, the call set-up is interrupted or the data call is interrupted. With this parameter, the user of the mobile station may, e.g. call-specifically, choose the lowest data transfer rate that in each case is sufficient for data transfer purposes. The parameters of the invention thus provide flexibility to the subscriber of the mobile station in the selection of the data transfer service. Alternatively, the parameters may be permanently set at the mobile station, or the mobile station may select the appropriate parameters. These parameters, i.e. the required and the desired level of service, allow the mobile communication network to vary the data transfer rates of individual mobile stations in accordance with the needs and the traffic load of the network, within the limits set by the parameters, without causing any disturbance to the users. In particular, these parameters allow the mobile communication network to reduce the data transfer rate if the new cell is not capable of providing the desired data transfer rate in connection with call set-up or handover. Thus, the number of calls interrupted or prevented due to the lack of resources decreases.

Instead of transferring the parameters, the mobile station may indicate said minimum and maximum requirements to the mobile communication network in a number of alternative ways, such as indicating the level of service. The minimum and the maximum requirements used are then selected in accordance with the indicated level of service in the mobile communication network.

It is also possible that the mobile station does not set any requirements for the minimum data

transfer rate, or it leaves the minimum performance to be freely chosen by the mobile communication network. As a result, the service of the data call may be continued in the new cell after the handover, totally
5 regardless of how the data call was served in the previous cell, or independently of the service provided by the new cell.

The invention also relates to a mobile communication system for implementing the method.

10 **Brief Description of the Drawings**

In the following, the invention will be described in closer detail by way of example with the aid of the preferred embodiments of the invention and with reference to the attached drawings, in which

15 Figure 1 illustrates a part of the mobile communication system in which the method of the invention may be applied, and

Figures 2, 3, 4 and 5 illustrate the TDMA frame structure,

20 Figures 6, 7, 8 and 9 are signalling diagrams, relating to call set-up, handover within one base station system BSS, handover between base station systems BSS, and handover between mobile services switching centres respectively, according to the
25 invention.

The Preferred Embodiments of the Invention

The present invention may be applied to high-speed data transfer in most digital TDMA based mobile communication systems, such as the Pan-European digital
30 mobile communication system GSM, DCS1800 (Digital Communication System), UMTS (Universal Mobile Telecommunication System), FPLMTS (Future Public Land Mobile Telecommunication System), etc.

35 Figure 1 describes a mobile communication system of the same type as GSM by way of example. GSM

(Global System for Mobile Communications) is a pan-European mobile communication system. Figure 1 shows very briefly the basic structure of the GSM system, not paying closer attention to its characteristics or other aspects of the system. The GSM system is described in greater detail in GSM recommendations and in "The GSM System for Mobile Communications", M. Mouly & M. Pautet, Palaiseau, France, 1992, ISBN:2-9507190-0-7, which are incorporated herein by reference.

A mobile services switching centre (MSC) is in charge of switching incoming and outgoing calls. It performs similar operations as the exchange of a public switched telephone network (PSTN). In addition, it also performs operations typical of mobile telecommunication only, such as subscriber location management, jointly with the subscriber registers of the network. The GSM system contains at least such subscriber registers as home location register (HLR) and visitor location register (VLR), which are not shown in Figure 1. Specific information on the location of the subscriber, such as the location area, are stored in a visitor location register VLR, the number of which is typically one per each mobile services switching centre (MSC). The location data in the HLR, in turn, indicates the VLR within the area of which a mobile station MS is located. Mobile stations MS are switched to the MSC by means of base station systems. A base station system BSS comprises a base station controller BSC and base stations BTS. One BSC is used for controlling several BTSs. The tasks of the BSC include e.g. handovers in such cases in which handover is performed within a base station or between two base stations both controlled by the same BSC. Figure 1 shows for clarity one base station system only, in which a base station controller BSC is connected with nine base stations BTS1-BTS9,

having coverages which, in turn, provide corresponding radio cells C1-C9.

The GSM system is a time division multiple access (TDMA) method in which time-division traffic takes place on the radio path in successive TDMA frames each of which consists of several time-slots. In each time-slot, a short information packet is sent in form of a radio frequency RF burst which has a finite duration and which consists of a set of modulated bits. The time-slots are mainly used for conveying control channels and traffic channels. On the traffic channels, speech and data are transmitted. On the control channels, signalling between a base station and mobile subscriber stations is carried out.

Channel structures used in the radio interface of the GSM system are defined in closer detail in the ETSI/GSM recommendation 05.02. The TDMA frame structure of the GSM system is illustrated by way of example in Figures 2-5. Figure 5 shows one TDMA basic frame which includes eight time-slots 0-7 used as traffic channels or control channels. Only one RF burst shorter than the duration of the time-slot is thus transmitted in each time-slot. Once one TDMA basic frame ends in time-slot 7, the time-slot 0 of the following basic frame immediately begins. Thus, 26 or 51 successive TDMA frames form one multiframe depending on whether a traffic channel or a control channel structure is in question, as illustrated in Figure 4. A superframe, in turn, consists of 51 or 26 successive multiframes depending on whether the multiframes have 26 or 51 frames, as illustrated in Figure 3. A hyperframe consists of 2048 superframes, as illustrated in Figure 2.

In normal operation, a mobile station MS is assigned at the beginning of a call one time-slot as a

traffic channel from one of the carrier frequencies (single-slot access). The mobile station is synchronized with the assigned time-slot for transmitting and receiving RF bursts.

5 In data transfer in accordance with the embodiment, when a mobile station MS requires a data transfer rate higher than can be provided by one traffic channel for transmission of user data, said MS is assigned a channel or a time-slot configuration that
10 comprises two or more time-slots from one or more time-slots in one or several frames by means of a so-called multi-slot access technique. It is not essential to the present embodiment which multi-slot access technique is used. An example of a multi-slot access technique for
15 which the present embodiment is well suited is disclosed in PCT/FI95/00248 and PCT/FI95/00249. In these applications, a high-speed signal is multiplexed to several low-speed channels (time-slots) transferred over the radio path and demultiplexed in a receiver back to one signal. These documents are incorporated herein by reference.



20 As it has been stated previously, however, problems arise in connection with the multi-slot access technique if there is not a sufficient number of channels available. This may occur in the call set-up phase and also in connection with handover.



25 In accordance with the present embodiment, the minimum and the maximum requirements for the data transfer rate of user data are indicated by the mobile station to the serving mobile communication network at the beginning of call set-up. Said requirements are two new parameters, in addition to the presently specified parameters used for establishing a data call. Indicating the requirements to the mobile communication network refers herein to all the manners in which the mobile
30
35



station can indicate the minimum and the maximum requirements, without limiting e.g. to direct transmission of the requirements as such. For example, the mobile station may indicate a desired level of service, in which case the MS is provided at least the performance of the data channel defined by the minimum requirement for this level of service, but not more than the performance of the data channel defined by the maximum requirement for this level of service.

In the following examples, these minimum and maximum requirements are defined with parameters "required level of service" and "desired level of service", but the requirements may be defined in other ways, as well. The desired level of service determines the data transfer rate, i.e. the channel configuration provided by one or more traffic channels or time-slots that the mobile station wishes to be able to use. Simultaneously, this desired data transfer rate is also the maximum data transfer rate to be allowed to the mobile station. The required level of service determines the minimum data transfer rate that must be provided for ensuring the continuity of data transfer. With the aid of these parameters, the mobile communication network may, depending on the resources of the network, assign a data call a data transfer rate which is within the limits of the desired data transfer rate and the required data transfer rate. Provided that not even the minimum data transfer rate can be provided, the data call or the call set-up is interrupted. It is also possible in some situations that the specific requirements set by the mobile station for the minimum level of service and the minimum data transfer rate are optional, i.e. the MS does not give any specific rate, but leaves the minimum performance to be freely chosen by the mobile communication network.

In the following, the embodiment will be described in closer detail by way of example, in connection with call set-up (Figure 6), handover within one base station system BSS (Figure 7), handover between
5 base station systems BSS (Figure 8), and handover between mobile services switching centres (Figure 9).

Figure 6 shows, in connection with call set-up, only the signalling that is essential to disclosing the embodiment. It must be noted, however, that in addition
10 to the described signalling messages, other messages are also transmitted in connection with the call set-up, which are not shown herein for clarity, however. As to the GSM system, for instance, this signalling is precisely defined in the GSM specifications concerning
15 call set-up.

In Figure 6, normal call set-up signalling takes place first, whereafter the MS sends a call set-up message SETUP, which is forwarded to the MSC. In accordance with the embodiment, the SETUP message
20 contains, in addition to the parameters normally required for setting up a data connection, two new parameters, the maximum desired data transfer rate DRMAX and the minimum required data transfer rate DRMIN. In the SETUP message of the GSM system, these parameters may be included in a Bearer Capability Information Element BCIE. The BCIE is disclosed in the GSM
25 recommendation 04.08, version 4.7.0, pages 435-443. The MSC sends a serving BSC an assignment request message (Assignment REQ), which is modified to contain parameters DRMAX and DRMIN. The BSC checks whether it has a sufficient capacity for serving the data call, and assigns the data call, depending on the current capacity, some time-slot configuration corresponding to the data transfer rate, which is within the limits of
30 parameters DRMAX and DRMIN. Thereafter, the BSC sends

35



the BTS serving the MS an assignment command message (Assignment Command), which contains the information on the time-slots assigned to the data call and on the assigned data transfer rate. The BTS sends the MS an assignment command message (Assignment Command), which contains the information on the time-slots assigned to the data call and on the assigned data transfer rate. The MS starts to prepare for data transfer in the assigned time-slots at the assigned data transfer rate, and sends the BTS an assignment acknowledgement (Assignment Complete). The BTS sends the BSC an acknowledgement (Assignment Complete). The BSC, in turn, sends the MSC an assignment acknowledgement (Assignment Complete), which contains the information on the data transfer rate assigned to the data call by the BSC. After this, normal call set-up signalling takes place for starting the transfer.

If the BSC is not capable of assigning the data call the time-slot configuration corresponding to the minimum required data transfer rate DRMIN due to lack of network resources, it will send a report to the MSC, in form of an Assignment Failure message. Then the MSC interrupts the call set-up. The network resources that determine the data transfer rate to be assigned to the data call include at least the traffic channels, i.e. the time-slots that are available at the BTS serving the MS at that particular moment.

Figures 7-9 show only the signalling that is essential to disclosing the embodiment. However, it must be noticed that in addition to the signalling messages described above, other messages are also sent in a handover situation, although these messages are not described herein for clarity. As to the GSM system, for instance, this signalling is precisely defined in the GSM specifications concerning call set-up.



In intra-BSS handover illustrated in Figure 7, the MS regularly reports the measurement results of the downlink signals of the adjacent cells to the BSC of the serving BSS (Meas Report). The BSC makes the handover decisions on the basis of the criteria of the radio path by utilizing these measurements, or for other reasons, such as for distributing the capacity. After making the handover decision, the BSC assigns the data call, depending on at least the time-slot resources of the target cell of the handover, a channel configuration that provides a data transfer rate which is at least the minimum required data transfer rate DRMIN and not higher than the maximum desired data transfer rate DRMAX. The data transfer rate (time-slot configuration) provided by the new cell is not necessarily the same as that provided by the previous cell. In other words, the data transfer rate may increase or reduce in the new cell in accordance with the available resources and within the limits of parameters DRMAX and DRMIN. The BSC or the BTS store parameters DRMAX and DRMIN for every MS that is located within their area and has an ongoing high-speed data call. Provided that the minimum required data transfer rate cannot be provided, the handover attempt will be interrupted, and an adjacent cell, second best in terms of other criteria and able to provide an adequate data transfer rate, will be selected as the new target cell for handover. The BSC sends the MS a handover command message (Handover Command), which contains the information on the assigned data transfer rate, and the description of the assigned time-slots. Now the MS is able to start communication with the channel configuration assigned in the new cell, and it sends an acknowledgement (Handover Completed) to the BSS. The BSS, in turn, sends the message Handover Performed to the MSC.

If the intra-BSS handover takes place within one cell without a change of the data transfer rate, the BSC may send the MS, instead of the Handover Command message, an Assignment Command, which contains the information on the assigned data transfer rate and the description of the assigned time-slots. Accordingly, the acknowledgement of the MS is Assignment Complete.

Figure 8 illustrates handover between two base station systems. An MS sends the serving BSS(old) the results of the adjacent cell measurements (Meas Report), which is the case in normal GSM signalling. BSS(old), or particularly its BSC, detects the need for handover to a cell of a new BSS(new), e.g. on the basis of the criteria of the radio path. BSS(old) sends the serving MSC a handover request Handover Required. This message contains, in addition to the standard GSM message, the maximum desired data transfer rate DRMAX and the minimum required data transfer rate DRMIN, given by the MS at the beginning of the data call. Either the BSC or the BTS stores parameters DRMIN and DRMAX for every MS that is located within their area and has an ongoing high-speed data call. The MSC sends the new BSS(new), or in particular its BSC, a Handover Request, in which the BSS(new) is requested to provide the requested service. This message also contains, in addition to the standard GSM message, parameters DRMAX and DRMIN. BSS(new) selects, depending on at least the time-slot resources of the handover target cell, a time-slot configuration that provides a data transfer rate which is not lower than the minimum required data transfer rate DRMIN and not higher than the maximum desired data transfer rate DRMAX. The data transfer rate (time-slot configuration) provided by the new cell is not necessarily the same as that in the previous cell. In other words, the data transfer rate may increase or reduce in the new cell in

accordance with the available network resources and within the limits of parameters DRMAX and DRMIN. Provided that the minimum required data transfer rate DRMIN can not be provided, the handover attempt will be interrupted. If there are network resources available, BSS(new) sends the MSC an acknowledgement message Request Acknowledge, which contains the information on the assigned data transfer rate, and the description of the assigned time-slots. BSS(old) sends the MS a Handover Command message, which contains the information on the assigned data transfer rate, and the description of the assigned time-slots. Now the MS is able to start communication in a new cell in base station system BSS(new) by using the assigned data transfer rate and the assigned time-slots. The MS sends BSS(new) an acknowledgement Handover Completed, and BSS(new) sends a similar acknowledgement Handover Completed to the MSC. Thereafter, the MSC releases the resources assigned for the data call in the old base station system BSS(old).

Figure 9 shows a handover between two MSCs. An MS sends the serving BSS(old) the results of the adjacent cell measurements (Meas Report), as in normal GSM signalling. BSS(old), or in particular its BSC, detects the need for handover to a cell of a new BSS(new) e.g. on the basis of the criteria of the radio path. BSS(old) sends the serving MSC-A a handover request Handover Required. This message contains, in addition to the standard GSM message, the maximum desired data transfer rate DRMAX and the minimum required data transfer rate DRMIN, given by the MS at the beginning of the data call. Either the BSC or the BTS stores parameters DRMAX and DRMIN for every MS that is located in their area and has an ongoing high-speed data call. MSC-A sends the new MSC-B a handover request Prep Handover Req, which contains, in addition to the

standard GSM message, the desired parameters DRMAX and DRMIN. MSC-B sends BSS(new), or in particular its BSC, a Handover Request, in which the BSS(new) is requested to provide the requested service. This message also
5 contains, in addition to the standard GSM message, parameters DRMAX and DRMIN. BSS(new) selects, depending on at least the time-slot resources of the handover target cell, a channel configuration that provides a data transfer rate which is not lower the minimum
10 required data transfer rate DRMIN and not higher than the maximum desired data transfer rate DRMAX. The data transfer rate (time-slot configuration) provided by the new cell is not necessarily the same as that in the previous cell. In other words, the data transfer rate
15 may increase or reduce in the new cell in accordance with the available resources and within the limits of parameters DRMAX and DRMIN. If the minimum required data transfer rate DRMIN can not be provided, the handover attempt will be interrupted. If there are resources
20 available, BSS(new) sends MSC-B an acknowledgement message Handover Request Acknowledge, which contains the information on the assigned data transfer rate, and the description of the allocated time-slots. Thereafter, MSC-B sends the serving MSC-A an acknowledgement message
25 Prep Handover Resp, which contains the information on the assigned data transfer rate, and the description of the assigned time-slots, in addition to the normal content specified in accordance with GSM. MSC-A sends the serving BSS(old) a handover command message Handover
30 Command, which contains the information on the assigned data transfer rate, and the description of the assigned time-slots. BSS(old) sends the MS a handover command message Handover Command, which contains the information on the assigned data transfer rate, and the description
35 of the assigned time-slots. Now the MS is able to start

The claims defining the invention are as follows:

1. A data method for data transmission in a time division multiple access (TDMA) mobile communication system, in which one or more time-slots may be allocated to a mobile station for data transmission, the method comprising the steps of:

5 indicating by the mobile station, upon setting up a data call, to a mobile communication network a desired level of service for a user data transfer,

10 assigning by the mobile communication network to the mobile station for a data call a channel configuration consisting of one or more time-slots in connection with call set-up or handover, said channel configuration depending on the resources currently available in the mobile communication network, and

enabling a data channel performance which is within the limits of said desired level of service.

15 2. A method as claimed in claim 1, comprising the further steps of:

indicating said desired level of service in terms of a maximum requirement for a user data transfer rate or a time slot configuration of the data call.

20 3. A method as claimed in claim 1, comprising the further steps of:

indicating said desired level of service in terms of a maximum requirement and a minimum requirement for a user data transfer rate or a time slot configuration of the data call.

25 4. A method as claimed in claim 3, comprising the further steps of:

interrupting a call set-up or a handover attempt of a data call by a mobile communication network if there are not sufficient resources available in the

15

20

25



mobile communication network for providing the minimum requirement set by said desired level of service.

5 5. A method as claimed in claim 1 or 2, whereby said resources of the mobile communication network include at least the time-slot resources of the serving cell and/or the time-slot resources of the target cell for handover.

10 6. A method as claimed in claim 5, whereby the call set-up comprises the steps of:

sending, by the mobile station, to a serving mobile services switching centre a call set-up message indicating said desired level of service for the requested data service,

15 sending from the serving mobile services switching centre to a base station controller of a serving base station system an assignment request message, which indicates said desired level of service,

20 selecting at the base station controller depending on at least the time-slot resources of a serving base station, a channel configuration that meets said desired level of service,

25 sending from the base station controller to the serving base station an assignment command message, which contains the information on the allocated channel configuration,

30 sending from the serving base station to the mobile station an assignment command message, which contains the information on the channel configuration allocated to the data call,

sending from the mobile station to the serving base station an assignment acknowledgement,

35 sending from the base station to the base station controller an assignment acknowledgement, and



sending from the base station controller to the mobile services switching centre an assignment acknowledgement.

5 7. A method as claimed in any of the preceding claims, comprising the further steps of:

recording in a serving base station system said desired level of service indicated by the mobile station, for controlling the channel configuration.

10 8. A method as claimed in any of the claims 1 - 5 or 7, whereby a handover within a base station system comprises the steps of:

measuring at the mobile station downlink signals of adjacent cells,

15 sending from the mobile station to a serving base station system results of said measurement,

determining at the serving base station system the need for handover within the base station system,

20 selecting at the serving base station system, depending on at least the time-slot resources of a target cell for handover, a channel configuration that meets said desired level of service,

25 sending from the serving base station system to the mobile station a handover command, which contains the information on the allocated channel configuration, and

changing the mobile station over to use the channel resources in accordance with the handover command in the target cell.

30 9. A method as claimed in any of the claims 1 - 5 or 7, whereby a handover between base station systems comprises the steps of:

measuring at the mobile station downlink signals of adjacent cells,

35 sending from the mobile station to a serving



base station system results of said measurement,

determining at the serving base station system
the need for handover to a new base station system,

5 sending from the serving base station system
to the serving mobile services switching centre a
handover request, which indicates said desired level
of service,

10 sending from the serving mobile services
switching centre to the new base station system a
handover request, which indicates said desired level
of service,

15 selecting at the new base station system,
depending on at least the time-slot resources of a
target cell for handover, a channel configuration
within limits of said desired level of service,

20 sending from the new base station system to
the serving mobile services switching centre an
acknowledgement message, which contains the
information on the allocated channel configuration,

25 sending from the serving mobile services
switching centre to the serving base station system a
handover command, which contains the information on
the allocated channel configuration, and

30 sending from the serving base station system
to the mobile station a handover command, which
contains the information on the allocated channel
configuration changing the mobile station over to use
the channel resources in accordance with the handover
command in the target cell.

35 10. A method as claimed in any of the claims
1 - 5 or 7, wherein a handover between mobile
services switching centers comprises the steps of:

measuring at the mobile station downlink
signals of adjacent cells,

35 sending from the mobile station to a serving

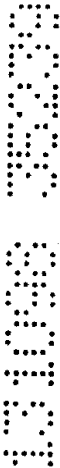

base station system results of said measurement,
determining at the serving base station
system the need for handover to a new base station
system located within the area of a new mobile
5 services switching centre,

10 sending from a serving base station system to
the serving mobile services switching centre a
handover request indicating said desired level of
service,

15 sending from the serving mobile services
switching centre to the new mobile services switching
centre a handover request indicating said desired
level of service,

20 sending from the new mobile services
switching centre to the new base station system a
handover request indicating said desired level of
service,

25 selecting at the new base station system,
depending on at least the time-slot resources of a
target cell for handover, a channel configuration
within limits of said desired level of service,

30 sending from the new base station system to
the new mobile services switching centre an
acknowledgement message, which contains the
information on the allocated channel configuration,

35 sending from the new mobile services
switching centre to the serving mobile services
switching centre a handover command, which contains
the information on the allocated channel
configuration,

40 sending from the serving mobile services
switching centre to the serving base station system a
handover command, which contains the information on
the allocated channel configuration,

45 sending from the serving base station system



to the mobile station a handover command message, which switching centre, contains the information on the allocated channel configuration, and

changing the mobile station over to use the
5 channel resources in accordance with the handover command in the target cell.

11. A method as claimed in claim 1, whereby the mobile station does not set any specific standards for the minimum performance of the user
10 data transfer, or

it leaves the minimum performance to be freely chosen by the mobile communication network.

12. A method as claimed in claim 1, comprising the further steps of:

15 indicating a maximum desired level of service by the mobile station, and

selecting a minimum level of service by the mobile communications network.

13. A time division multiple access (TDMA)
20 mobile communication system, in which one or more time-slots may be allocated to a mobile station for data transmission, wherein

the mobile station is arranged to indicate, upon setting up a data call, to the mobile
25 communication network a desired level of service for a user data transfer,

the mobile communication network is arranged to assign the mobile station for a data call a
30 channel configuration consisting of one or more time-slots in connection with call set-up or handover, said channel configuration depending on the resources currently available in the mobile communication network and enabling a data channel performance which is within the limits of said desired level of
35 service.

BR
S
D
D



14. A system as claimed in claim 13, wherein said indication of said desired level of service is in terms of a maximum requirement for a user data transfer rate or a time slot configuration of the data call.

15. A system as claimed in claim 13, wherein said desired level of service is presented in terms of a maximum requirement and a minimum requirement for a user data transfer rate or a time slot configuration of the data call.

16. A system as claimed in claim 13, wherein a minimum level of service is undefined by the mobile station.

17. A system as claimed in claim 13, wherein a minimum level of service is selectable by the mobile communications network.

18. A system as claimed in claim 15 or 17, wherein

the mobile communication network is arranged to interrupt a call set-up or a handover attempt of a data call if there are not sufficient resources available in the mobile communication network for providing the minimum requirement or the minimum service of level.

19. A system as claimed in any one of claims 13 - 18, wherein said resources of the mobile communication network include at least the time-slot resources of the serving cell and/or the time-slot resources of the target cell for handover.

SECRET



20. A method for data transmission in a time division multiple access (TDMA) mobile communicator system, in which one or more time-slots may be allocated to a mobile station for data transmission, said method being substantially as hereinbefore described with reference to Figs. 1 to 9 of the accompanying drawings.

5

21. A time division multiple access (TDMA) mobile communication system, in which one or more time slots may be allocated to a mobile station for data transmission, said system being substantially as hereinbefore described with reference to Figs. 1 to 9 of the accompanying drawings.

10

DATED this Twelfth Day of October 1998

Nokia Telecommunications OY

Patent Attorneys for the Applicant

SPRUSON & FERGUSON

15

SPRUSON & FERGUSON



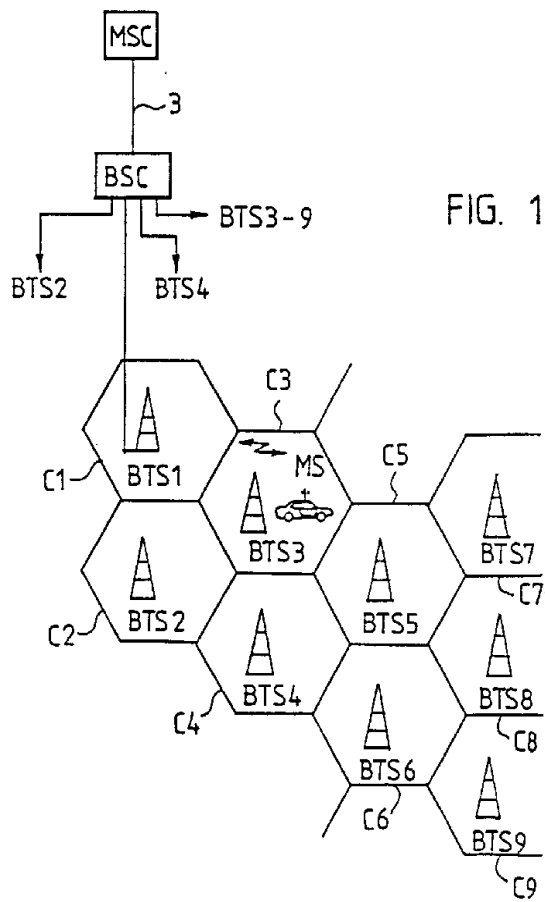

FIG. 1

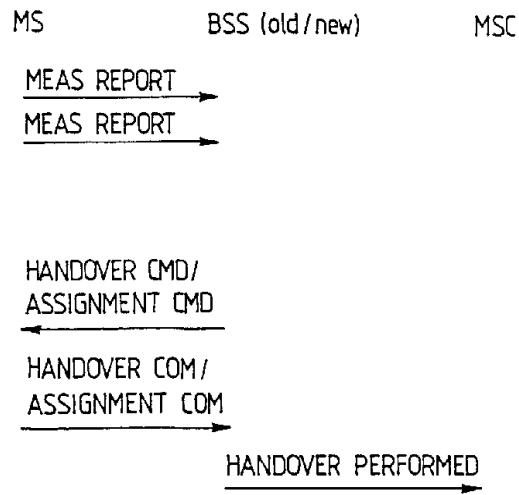
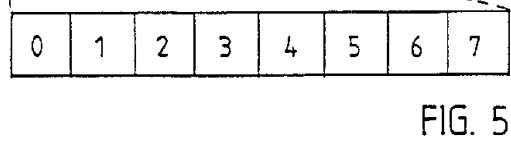
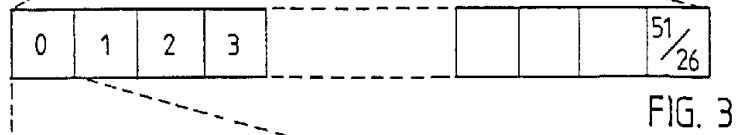
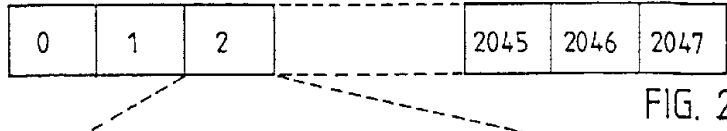

FIG. 7

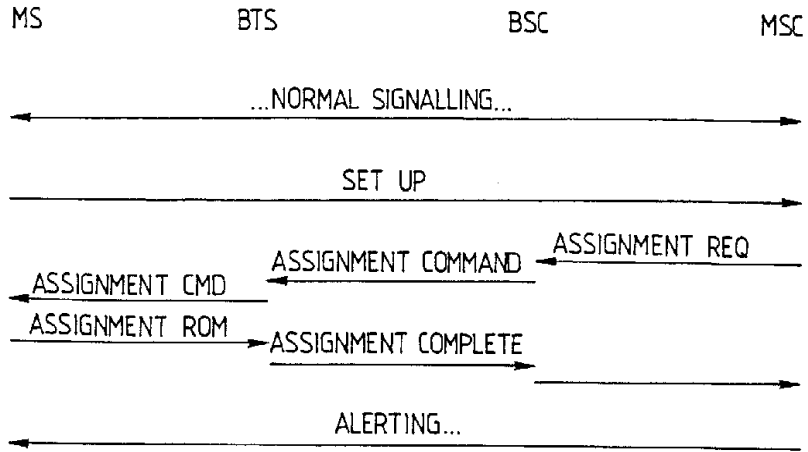

FIG. 6

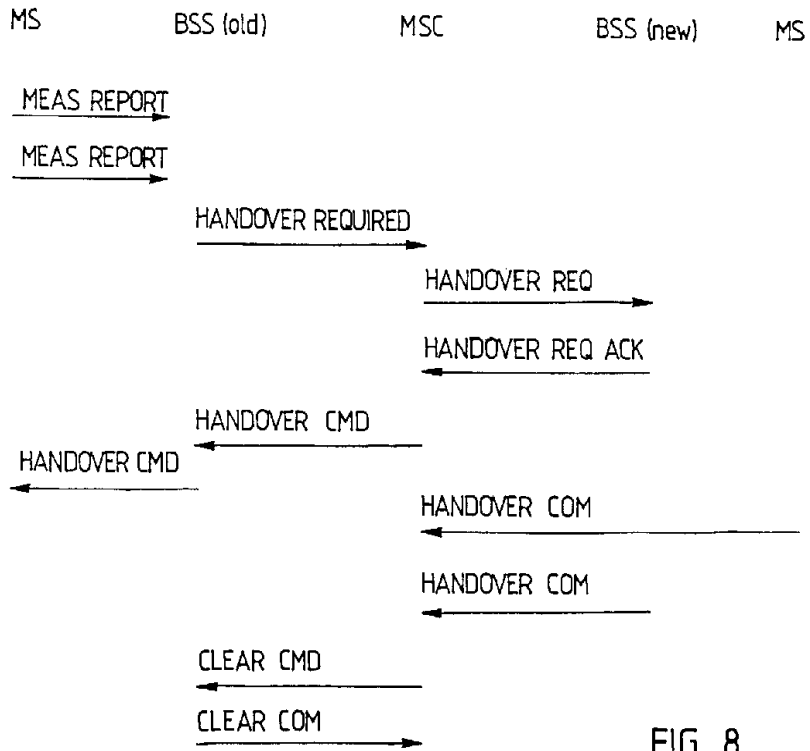

FIG. 8

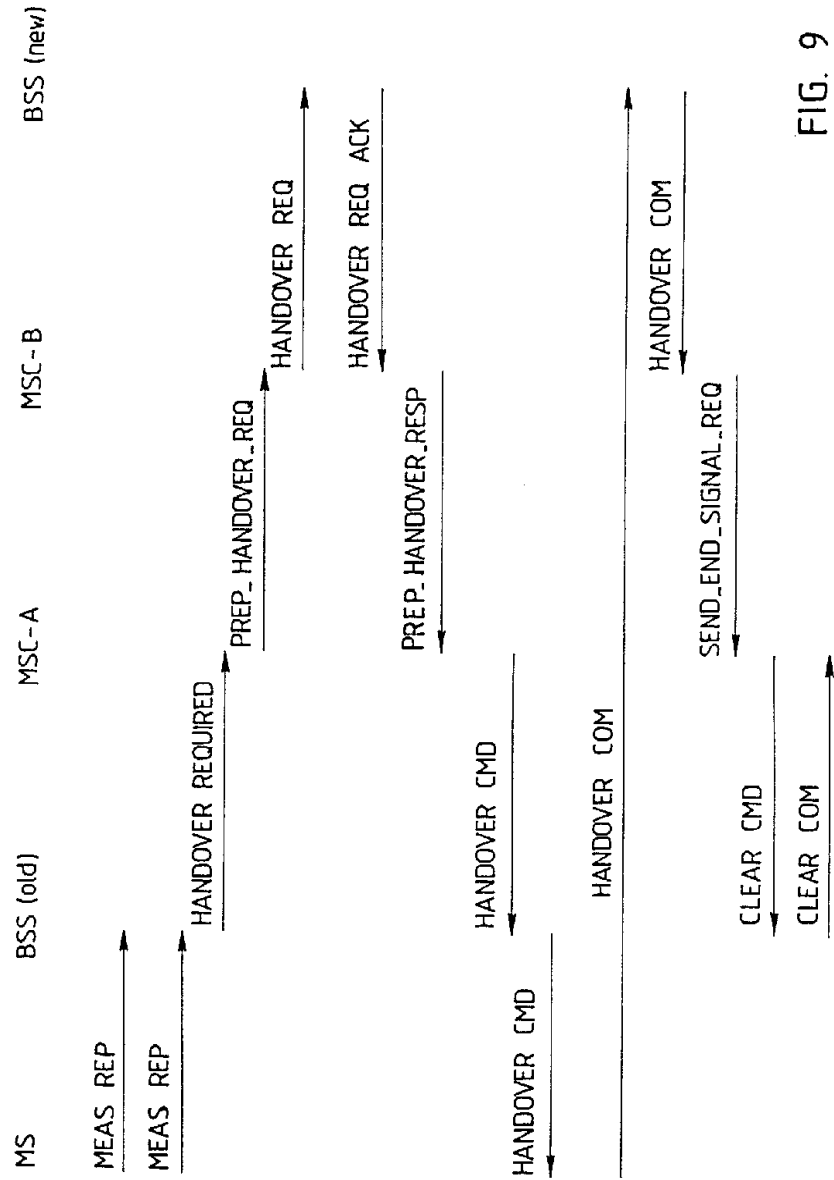

FIG. 9