

May 23, 1972

C. R. SYKES ET AL

3,664,627

ADJUSTABLE SUPPORTS

Filed Feb. 10, 1970

3 Sheets-Sheet 1

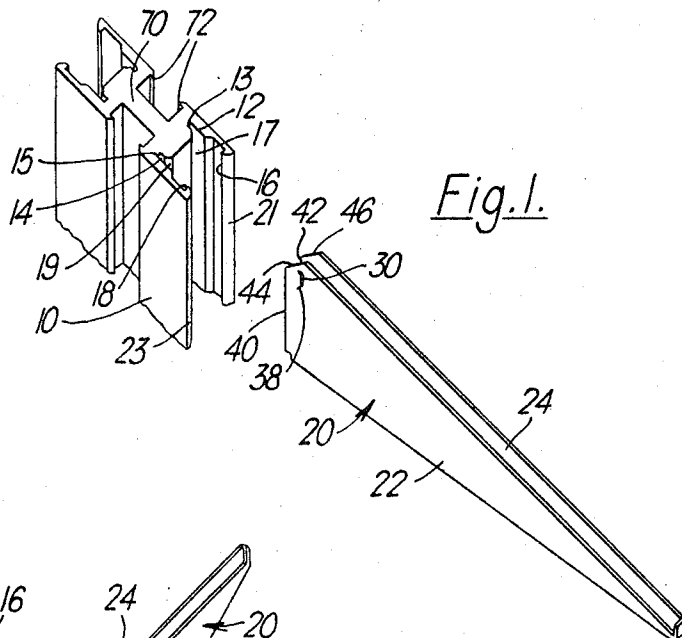

Fig. 1.

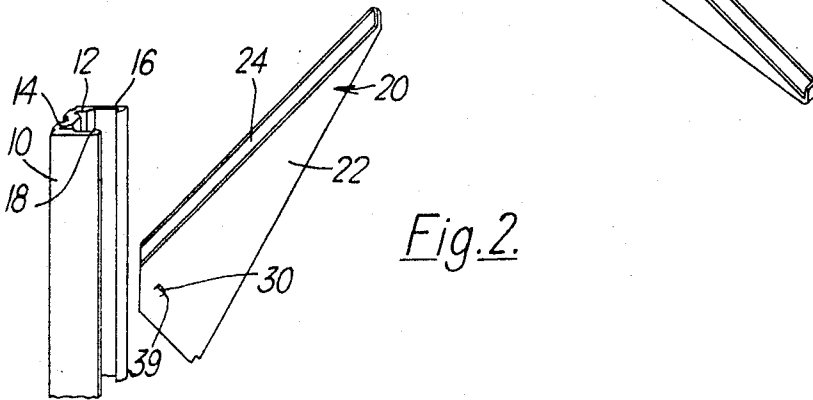

Fig. 2.

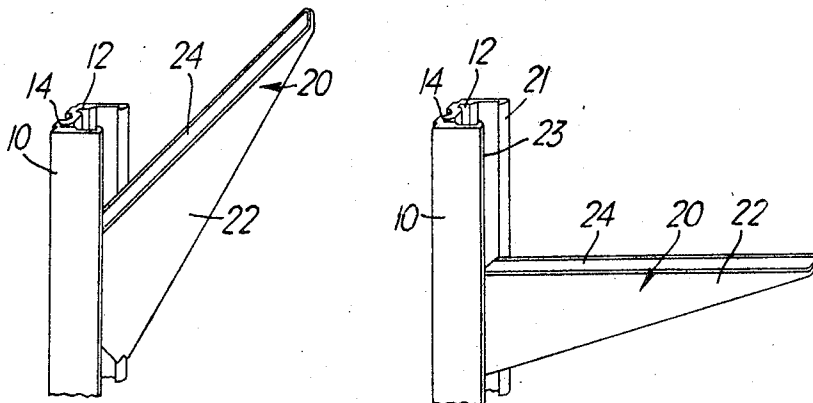

Fig. 3.

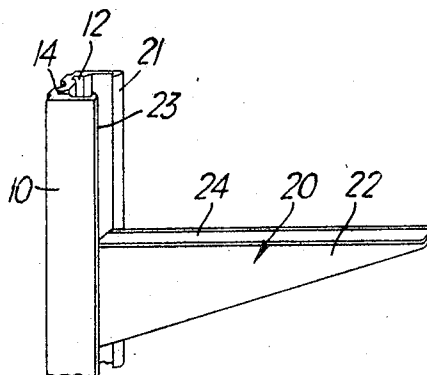

Fig. 4.

May 23, 1972

C. R. SYKES ET AL

3,664,627

ADJUSTABLE SUPPORTS

Filed Feb. 10, 1970

3 Sheets-Sheet 2

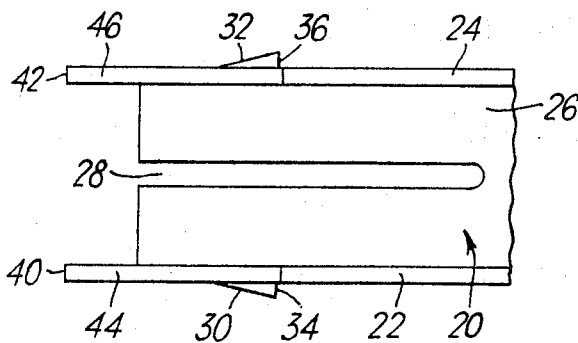
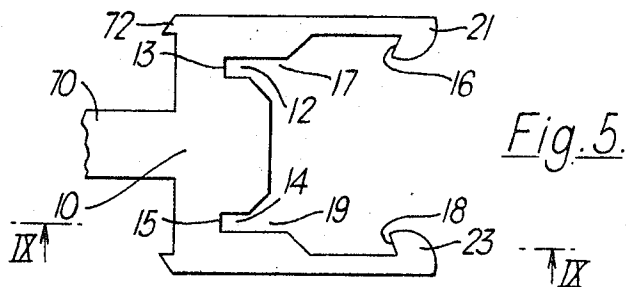

Fig. 6.

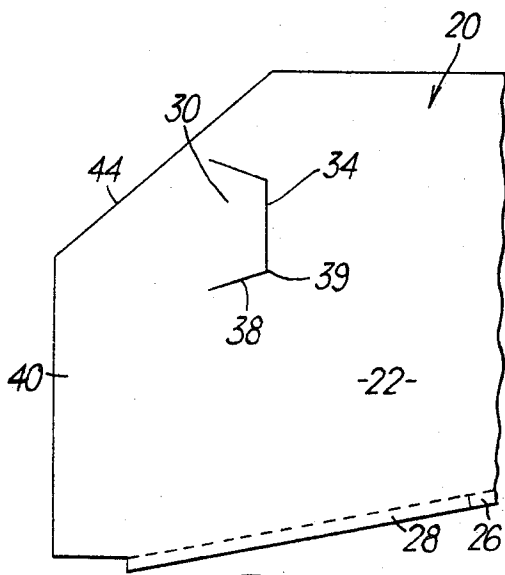

Fig. 7.

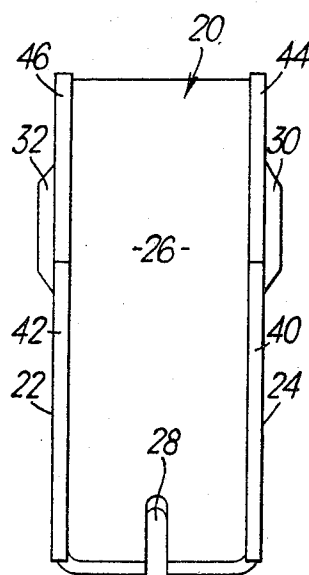

Fig. 8.

May 23, 1972

C. R. SYKES ET AL
ADJUSTABLE SUPPORTS

3,664,627

Filed Feb. 10, 1970

3 Sheets-Sheet 3

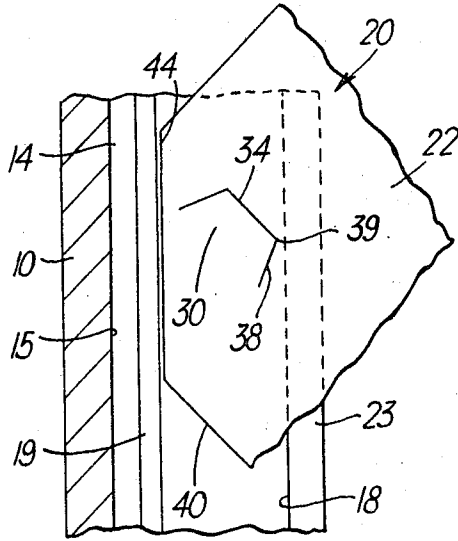

Fig. 9.

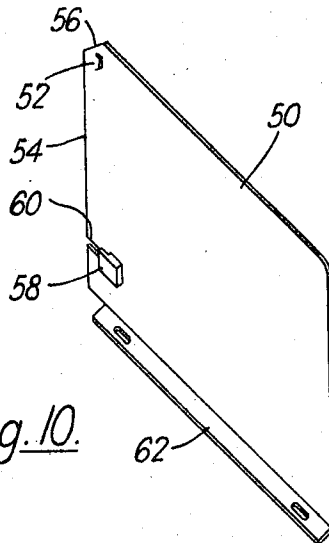

Fig. 10.

1

3,664,627

ADJUSTABLE SUPPORTS

Christopher Charles Sykes, London, and Charles Henry Pentland Denroche, Kingston-on-Thames, England, assignors to Nexus Limited, London, England

Filed Feb. 10, 1970, Ser. No. 10,193

Claims priority, application Great Britain, Feb. 21, 1969, 9,565/69

Int. Cl. A47g 29/02

U.S. Cl. 248—246

14 Claims

ABSTRACT OF THE DISCLOSURE

Shelving structure comprising uprights and brackets, each upright being a simple extrusion and having one or more forwardly opening grooves along its rear face, the upright being preferably U-sectioned to have a forwardly extending wall, out of which laterally projects a respective rearwardly facing abutment face; a bracket comprises one or two sidewalls out of which extends a respective projection. With the bracket tilted upwards, the projection can be hooked behind the abutment face; lowering of the bracket then forces the end edge of the sidewall into the groove. The bracket can thereby be releasably and rigidly held at any point along the length of the upright without further fastening. The uprights can be composite free-standing and interconnectable.

This invention concerns shelving structures having upright channel members, sometimes called standards, and brackets which can be releasably applied to the upright channel members to project therefrom. The brackets can be placed anywhere, or can be moved to lie anywhere, along the upright channel members.

Known constructions which have permitted this adjustability but which have not also used screw-threaded fasteners or complicated friction-grip arrangements, have not provided the strength required of them in service.

For brevity in this specification, the upright channel member is referred to merely as "the upright." Moreover, the specification and claims assume the upright to be vertical, and assume the bracket when assembled thereon to project horizontally forwards towards the viewer. It is to be understood, however, that the two parts are made and sold as separate loose components, and can be mounted having other dispositions. The components in a disconnected state, or lying when assembled in other than vertical and horizontal attitudes, lie within the scope of this invention.

According to this invention, a shelving structure comprises an upright having along its length a groove which opens forwards, and an abutment face which lies forwards or nearly forwards of the groove, but which faces substantially rearwards, and a bracket having a sidewall, a lateral projection which extends from the sidewall and which can be placed to abut the abutment face when the bracket is applied to the upright in an upwardly tilted attitude, the sidewall further having an edge portion which lies below and rearwards of the projection, and which becomes received in the groove by rotating the bracket downwards about the projection until the bracket projects horizontally forwards.

Preferably the projection lies spaced substantially from the upper horizontal edge of the bracket, the part of the bracket lying generally above and rearwards of the projection being cut away to define an edge which lies a small distance rearwards of the projection when the bracket lies tilted upwards.

Preferably the projection is an integral part of the bracket, which is formed by indenting the bracket wall to

2

form a protrusion which slopes acutely outwards towards the abutment face. Preferably the projection lies laterally spaced from the groove, which arrangement makes the stamping operation of the otherwise flat bracket to form the projection, particularly convenient. The complex sectional form which is required of the upright is readily obtained by extruding the upright. The "lateral" direction is that which is perpendicular to both the vertical and the forward directions, i.e. transverse.

Uprights and brackets constructed in accordance with this invention are described below with reference to the accompanying drawings in which:

FIG. 1 is a perspective "exploded" view of a double-upright (explained below) and a first type of bracket;

FIGS. 2, 3 and 4 are perspective views of a simpler type of upright, the bracket being shown in three different relationships thereto, FIG. 2 showing the initial tilt which the bracket has in order to introduce it into the upright, FIG. 3 the subsequent position when it lies within the upright but tilted, and FIG. 4 the in-service position to which the bracket has been rotated downwards from the FIG. 3 position;

FIG. 5 is a horizontal section through the type of upright seen in FIG. 1;

FIG. 6 is a plan of merely that end of the bracket which co-operates with the upright;

FIG. 7 is a side elevation of FIG. 6;

FIG. 8 is an end view of FIGS. 6 and 7, but showing the entire bracket;

FIG. 9 is a fragmentary sectioned elevation taken as indicated by the arrows IX—IX seen in FIG. 5 with the bracket lying in a tilted attitude; and

FIG. 10 is a perspective view of a second type of bracket.

An upright 10 is of uniform, generally U-shaped section, having in its rear face two grooves 12 and 14 which open forwards, which is to the right as viewed in FIGS. 3, 4 and 5. The rear surfaces of the grooves 12 and 14 are respectively enumerated as 13 and 15, and the open ends as 17 and 19. The upright further has abutment faces 16 and 18, lying forwards but slightly transversely of the grooves 12 and 14, but facing substantially rearwards. More specifically, the abutment faces 16 and 18 are disposed to face slightly laterally outwards, in a rearward sense. The abutment faces are formed on the rear faces of two respective inward protuberances 21 and 23 at the free ends of the sides of the upright.

The first type of bracket 20, seen in FIGS. 2 to 9 is channel-sectioned, having opposite side walls 22 and 24 joined by a base wall 26, which can only be totally seen in FIG. 8, keeping in mind that the surface 26 is sloping upwards into the paper. The bracket is completely symmetrical about a forwardly extending vertical plane through its centre. The bracket tapers, being deepest where it co-operates with the upright, the base surface 26 sloping uniformly upwards and outwards to the free end of the bracket. The portion of the base wall adjacent to the deep end of the bracket has a slot 28. The sidewalls 22 and 24 of the bracket 20 have respective projections 30 and 32, which as seen best in FIGS. 6 and 7, are acutely outwardly and forward tapering portions of the sidewalls; they terminate forwards in respective flat vertical surfaces 34 and 36. Sloping downwards and rearwards from the lower end of the faces 34 and 36, are respective surfaces 38; although only the surface 38 below the face 34 is visible in the drawings. At the junctions of the surfaces 34, 36 and the surfaces 38, are corners 39.

Rearwards of the projections 30 and 32, the sidewalls 22 and 24 terminate in respective vertical edge portions 40 and 42. The parts of the sidewalls lying rearwards of and above the projections are cut away to define sloping

edges 44 and 46 which extend in the same general direction as the surfaces 38. The perpendicular distance between the surface 34 or 36, and the edge 40 or 42 is substantially equal to the distance between the abutment face between the abutment face 16 or 18 and the rear face 13 or 15 of the groove. The maximum distance between the faces 38 and the edge 44 or 46 is less than this, being less than or equal to the perpendicular distance between the forward open end 17 or 19 of the grooves and the abutment face 16 or 18.

To apply the bracket 20 to the upright 10, the bracket is held in the position seen in FIG. 2, with its edges 44 and 46 vertical, and those edges are pressed rearwards into the upright. The sidewalls fit fairly tightly between the forward edges of the upright, and have to flex inwards for the projections 30 and 32 to pass into the upright. This can be assisted by manually squeezing the sidewalls laterally together, which is facilitated by the slot 28 in the base wall. Upon passing rearwards of the protuberances 21 and 23, the projections and hence the sidewalls can flex back laterally outwards so that the faces 38 abut or lie directly rearwards of the abutment faces 16 and 18. This is the position seen in FIGS. 3 and 9. The bracket is then turned downwards about a horizontal transverse axis. This causes the projections 30 and 32 to abut the abutment faces 18 and 16 and the axis of turning passes through the points of contact of the projections and the faces. The points of contact are, through most of the turning, the corners 39, and as the bracket is lowered, successively lower parts of the edge portions 40 and 42 pass into the grooves 14 and 12 until the bracket is horizontal, whereupon the entire lengths of the edges 40 and 42 abut the rear faces of the grooves, and the surfaces 34 and 36 abut the abutment faces 18 and 16. This position is seen in FIG. 4. The bracket can only be removed from the upright by flexing its sidewalls laterally together to free the projections from the abutment surfaces. Such movement is prevented by the lateral confinement presented by the sides of the grooves—which closely abut the opposite faces of the respective edge portions when the bracket lies horizontal. When a load is applied to the bracket, for example being a weight on a shelf supported by the bracket, the edges 40 and 42 and the faces 34 and 36 are pressed into tighter abutment with the respective surfaces of the upright, and when the load increases substantially, the corners 39 bite into the abutment faces of the upright.

The major part of the bottom wall 26 of the bracket, being integral with the two sidewalls, maintains them rigidly opposite one another; each wall prevents the other from bending laterally in such a way as might permit a projection to escape from engagement with its abutment surface.

The second type of bracket, seen in FIG. 10, has a single sidewall 50. It has a projection 52, an edge portion 54 and a sloping edge 56 exactly as each sidewall of the first bracket. Below the projection 52 is a clip 58, which is received in a slot 60 extending forwards from the edge portion 54. In plan view, the clip has substantially the shape of an H, the two lower parallel arms of which tightly grip that part of the sidewall 50 lying forwards of the slot. The other two parallel arms overlie opposite sides of the slot and sidewall. The one arm, not visible in FIG. 10, abuts the face of the sidewall and the other arm, visible, is spaced from the sidewall sufficiently to grip the protuberance 23 therebetween. An apertured flange 62 extends laterally and horizontally from the lower edge of the wall 50, extending from the same side of the wall as the projection 52.

The second bracket is applied to the groove 14 of an upright in exactly the same manner as is the sidewall 22 of a first bracket. When its edge portion 54 lies within the groove 14, it can act as, for example, a book-end to a shelf which is supported on its flange 62. Being a single wall, it is not protected from deflection to the right—as viewed in FIG. 10—which deflection would disengage its

projection 52 from the abutment face 18. That deflection can be prevented by fastening the shelf to the apertured bracket. Instead of being apertured, the flange could for example have its free edge upturned to present a rib for engaging a slot in an undersurface of the shelf.

A further bracket mounted in the groove 12 would have its flange and projection extending rightwards from its sidewall, to be a mirror image of the bracket described.

Both types of bracket described can be easily applied to an upright without using any tools. They can be adjusted to any position vertically on the upright by simply tilting them upwards slightly, and moving them as required.

The upright seen in FIGS. 2, 3 and 4 and which is U-shaped, can be fastened to a wall by screw passing through its rear wall, or two uprights can be fastened back-to-back, and can be used free-standing. To achieve the same result, the double upright seen in FIG. 1 can be used. The two uprights are connected by a wall 70, and sidewalls of the two uprights have extensions 72 which define T-shaped slots on opposite sides of the wall 70. The slots can receive horizontal beams, not shown, to rigidly connect two double uprights together. At each end of the beam is a locking screw to fasten it to an upright.

For an upright to be free-standing it is necessary to rigidly mount it on feet. These can be conveniently constructed in the form of a simple beam of rectangular cross-section, and having a slot in one edge; the slot can receive the rear wall of the upright or uprights when the unslotted edge rests on the ground. An upwardly-outwardly tapering wedge-piece which is also received in the slot and which is adjustably screw-fastened to the underlying part of the beam, can be used to rigidly fasten the upright to the beam. The feet extend forwards and rearwards of the upright.

The structures of uprights, double uprights, first and second type brackets, shelves, beams and feet can be mounted on adjustable jacking devices to level them or to press them against a ceiling, or can be mounted on casters or slides to make them mobile. The upper ends of the beams can have capping pieces for a neat finish.

A projection from the wall of a bracket does not have to lie slightly transversely of its associated edge portion; the two could lie directly forwards-rearwards of one another. The abutment face of the upright would then lie directly forwards of its respective groove.

The upright could be T-sectioned rather than U-sectioned; the abutment surfaces extending laterally at the foot of the stem of the T, and the grooves opening downwards from the head. An upright which will only have to receive the second type of bracket could simply have one groove and one abutment face.

If the projection were to be positioned adjacent to the upper edge of the bracket, the cut away portion of the sidewall 22, 24 or 50, which defines the sloping edge 44, 46 or 56 would not be necessary. The construction shown has the advantage, however, that the projection is stamped into the plane sidewall, as an acutely angled ramp, with preferably no severing of the material of the sidewall, and the load exerted on the projection by the abutment face is compressive, and is sustained by an area surrounding the projection.

In the bracket constructed in accordance with this invention, lateral deflection of the bracket is prevented by the groove which tightly receives the edge portion. The projection can therefore be narrow, and can be formed by indenting an acute angled ramp in the sidewall, which is therefore compressed and sheared by applied load. Metal is strong in supporting a compressive and shearing load.

The friction between the edge portion and the groove can be designed to be so strong that the bracket will fracture before sliding; as described above the friction is increased by the load.

5

Earlier constructions have had to use friction material, or teeth on the rear wall of the upright to achieve the necessary friction, and a simply extruded upright has not been adequate in itself. Its rear surface has had to be serrated, or has had to receive a rubber coating.

Although the described brackets have extended horizontally forwards in their "in service" positions, there are occasions when brackets are designed to incline upwards or downwards when in use, for example when displaying magazines. Brackets having these dispositions are within the scope of this invention, which is concerned in spirit, with the co-operation between a projection on, and an edge portion of, a sidewall of the bracket, and with a groove and an abutment face in the upright. These features are independent of the form of the body of the bracket.

The brackets, the uprights and all the components described can be metal, or can be moulded as extruded in plastics materials.

We claim:

1. Structure for building shelving, said structure comprising an upright which is shaped to define along its length a forwardly opening groove, and to define an abutment face which lies substantially forwards of said groove, and which faces substantially rearwards; and a bracket having a sidewall, a lateral projection which extends from said sidewall and which can be placed to abut said abutment face when said bracket is applied to said upright in an upwardly tilted attitude, said sidewall further having an edge portion which lies below and rearwards of the projection, and which becomes laterally confined by the sides of the groove by rotating the bracket downwards about said projection until the side bracket projects forwards.

2. Structure as claimed in claim 1 in which said abutment face of the upright lies spaced slightly laterally of said groove, and in which said projection on said bracket lies spaced slightly laterally of said edge portion.

3. Structure as claimed in claim 1 in which said projection lies substantially below the upper edge of the bracket, and the bracket has a cut-away portion lying generally rearwards of and above the projection.

4. Structure as claimed in claim 3 in which said cut-away portion defines an edge on the bracket, which edge lies vertical when the bracket lies tilted for application to the upright.

5. Structure as claimed in claim 1 in which the bracket has two interconnected sidewalls which have respective projections extending in opposite directions.

6

6. Structure as claimed in claim 5 in which the projections extend outwards from the sidewalls, and in which the upright is of U-shaped section, the rear wall of the upright having two grooves, and the interior surface of the sides of the upright terminating in two protuberances, the rear surfaces of which define the abutment faces.

7. Structure as claimed in claim 5 in which the sidewalls of the bracket are interconnected by a base wall, the part of the base wall adjacent to the upright being slotted so that the sidewalls can be flexed towards one another.

8. Structure as claimed in claim 1 in which the projection defines two edges the first lying vertical when the bracket is horizontal, the second being oblique and adjacent to the first and lying below the first.

9. Structure as claimed in claim 1 in which the projection is an actuately sloping ramp.

10. Structure as claimed in claim 1 in which the bracket is of sheet metal, and the projection is stamped into a sidewall thereof without severing of said sheet metal by the stamping operation.

11. Structure as claimed in claim 1 in which the lower edge of the sidewall slopes upwards in the forward direction.

12. Structure as claimed in claim 1 in which the lower edge of the sidewall is horizontal, and a flange extends transversely therefrom, extending in the same transverse direction from the sidewall as does the projection.

13. Structure as claimed in claim 1 in which the sidewall has a slot extending forwards from its edge portion, the slot accommodating a clip which grips the upright against relative lateral movement when the bracket is rotated downwards into the upright.

14. Structure as claimed in claim 1 in which there are two uprights which are rigidly mounted for their grooves to open in opposite directions.

References Cited

UNITED STATES PATENTS

3,039,727	6/1962	Engle et al.	248—245 X
3,203,375	8/1965	Schroeder	248—246 X
3,513,606	5/1970	Jones	248—245 X

WILLIAM H. SCHULTZ, Primary Examiner