

Oct. 15, 1935.

J. A. WRAY

2,017,193

PRINTING PRESS

Filed Nov. 7, 1932

3 Sheets-Sheet 1

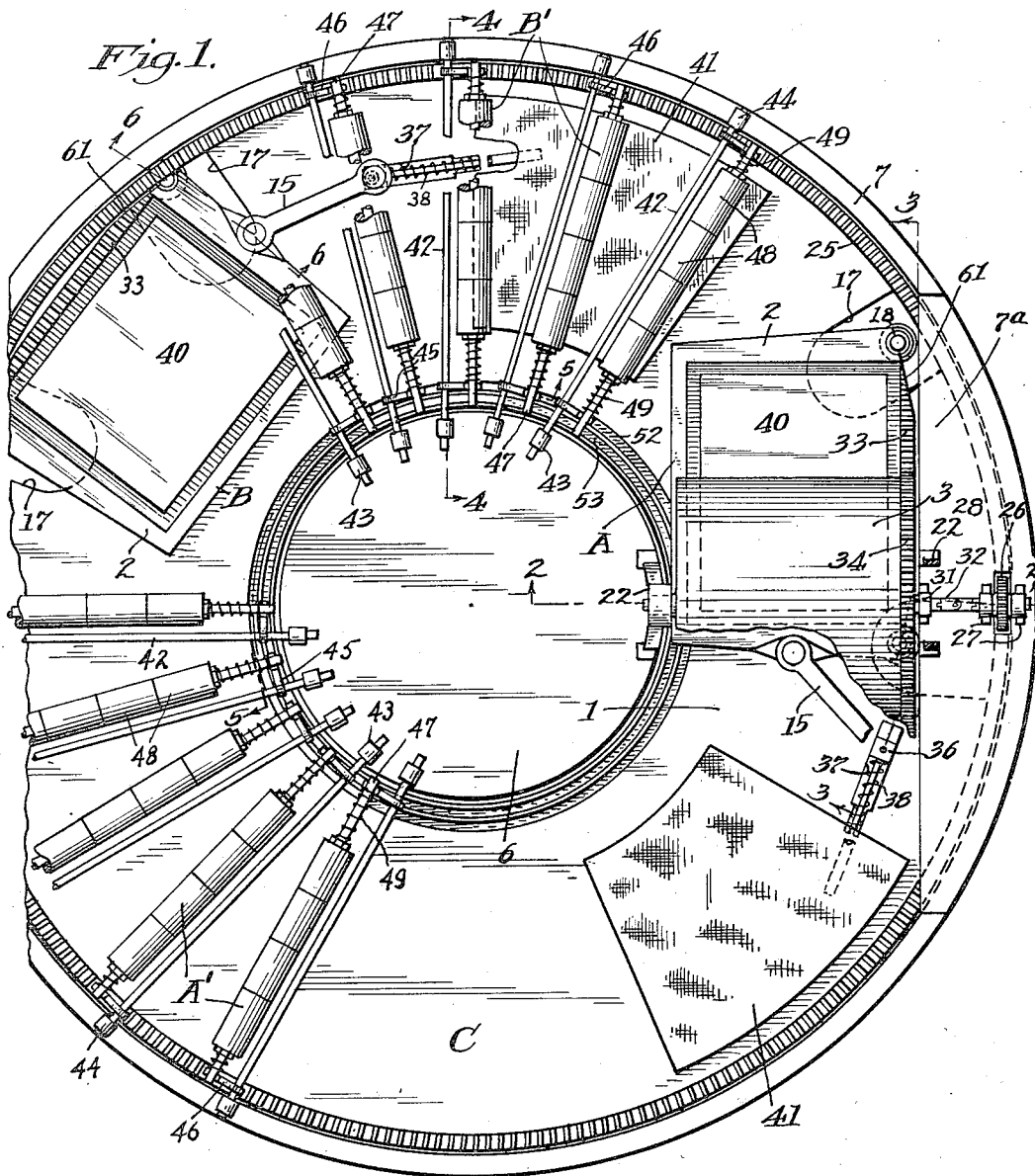

INVENTOR.
James A. Wray

BY *R. W. Smith*
ATTORNEY.

Oct. 15, 1935.

J. A. WRAY

2,017,193

PRINTING PRESS

Filed Nov. 7, 1932

3 Sheets-Sheet 2

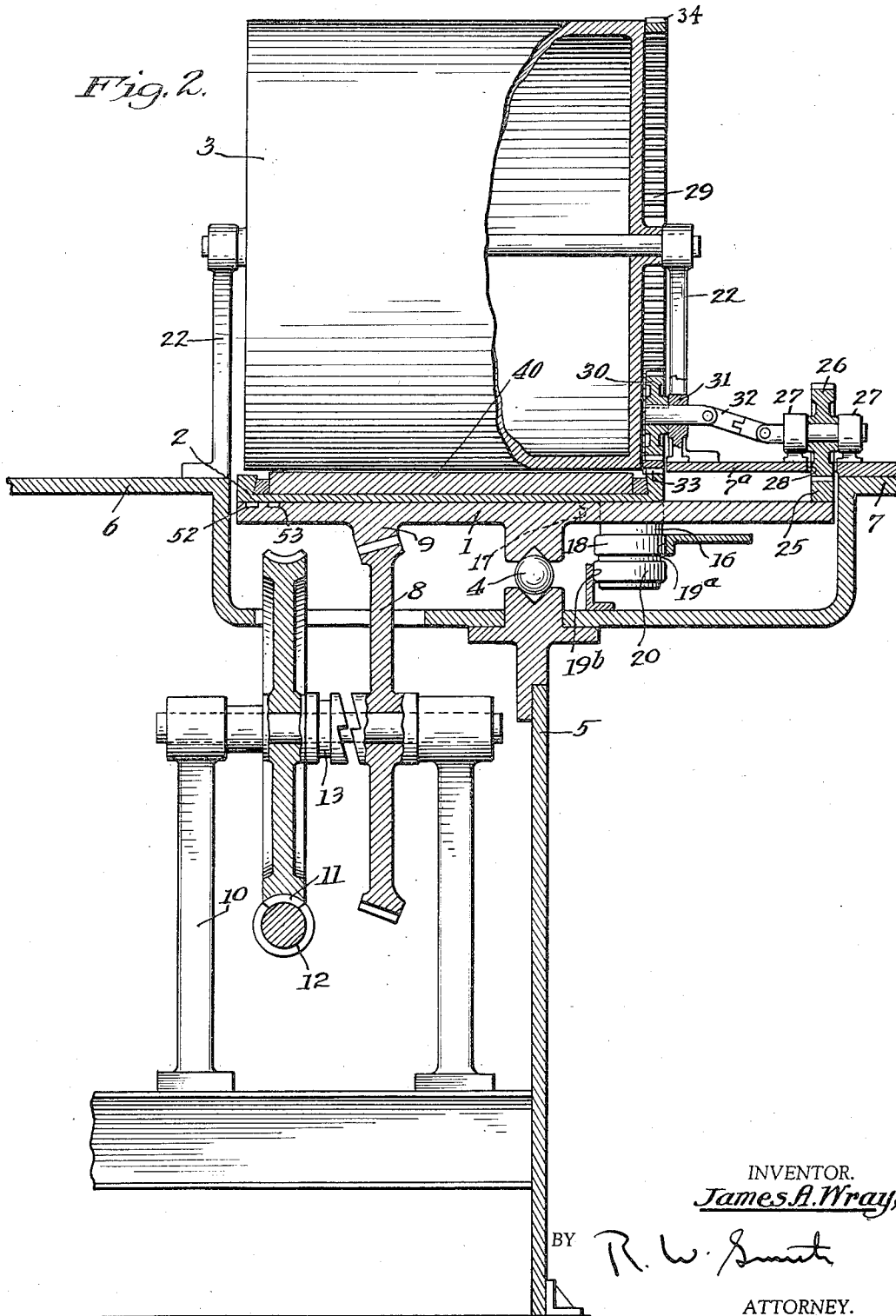

Oct. 15, 1935.

J. A. WRAY

2,017,193

PRINTING PRESS

Filed Nov. 7, 1932

3 Sheets-Sheet 3

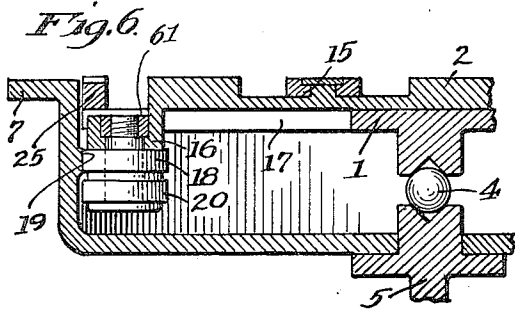
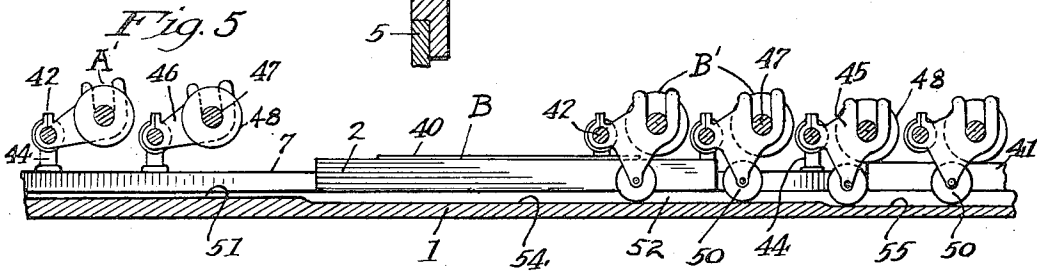
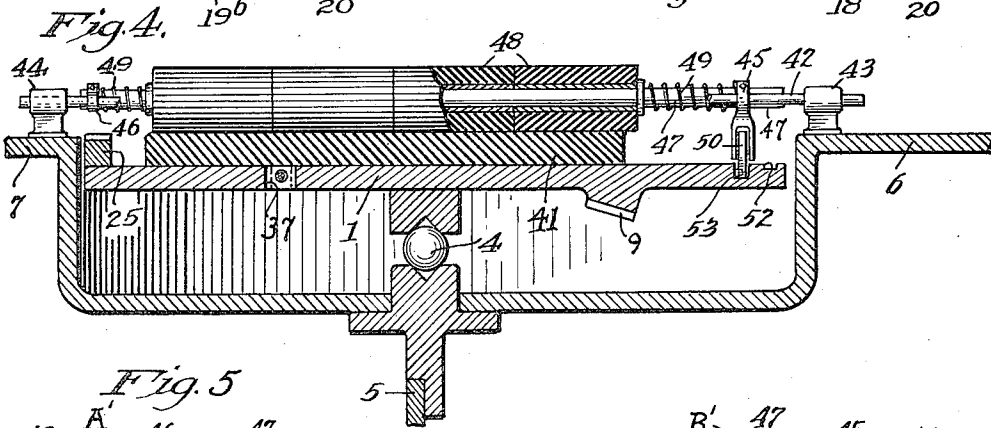
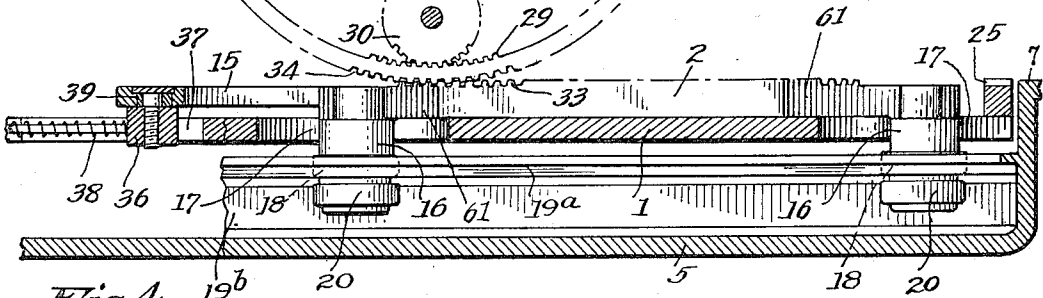
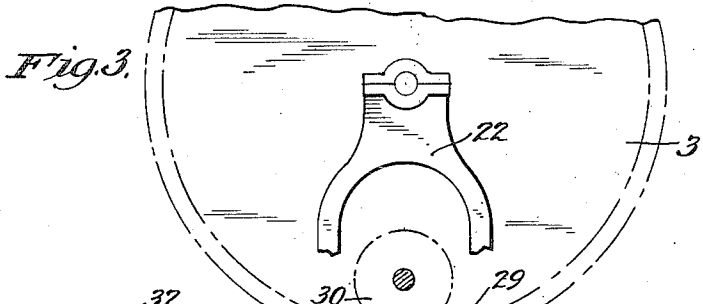

INVENTOR.
James A. Wray,

BY *R. W. Smith*
ATTORNEY.

UNITED STATES PATENT OFFICE

2,017,193

PRINTING PRESS

James A. Wray, Los Angeles, Calif.

Application November 7, 1932, Serial No. 641,508

6 Claims. (Cl. 101—186)

This invention is a printing press, and has for its object to provide novel means for printing multi-color work.

More particularly it is the object of the invention to successively move a plurality of printing frames past a paper carrying means, with the printing frames inked in the various colors and the paper carrying means moving the paper into printing contact with each of the successive printing frames for printing the various colors in matched relation.

It is a further object of the invention to preferably mount the printing frames in circumferentially spaced relation on a rotatable circular bed, with the paper carried by a cylinder which overlies the circular bed for rotation on an axis radially thereof, and the cylinder being adapted to make a complete revolution as each printing frame moves past the same, so as to align the same area of the paper with each of the successive printing frames.

It is a still further object of the invention to guide the printing frames as they successively move into operative position with relation to the overlying cylinder, so that during the printing operation each frame moves along a chord of the circular bed and at right angles to the axis of the rotating cylinder for properly aligning the paper with the printing frames; and the invention includes a driving connection whereby chordal movement of each printing frame is synchronized with rotation of the cylinder during printing contact.

It is a still further object of the invention to ink the various printing frames in different colors prior to their movement past the cooperating cylinder which carries the paper, and to automatically contact each of the plurality of different colored inking means with only its corresponding printing frame, so as to properly distribute the various colors to their corresponding printing frames.

Further objects of the invention will be readily understood from the following description of the accompanying drawings, in which:

Fig. 1 is a plan view of the printing press.

Fig. 2 is an enlarged vertical section on the line 2—2 of Fig. 1.

Fig. 3 is an enlarged vertical section on the line 3—3 of Fig. 1.

Fig. 4 is an enlarged vertical section on the line 4—4 of Fig. 1.

Fig. 5 is an enlarged vertical section on the line 5—5 of Fig. 1.

Fig. 6 is an enlarged vertical section on the line 6—6 of Fig. 1.

The printing press comprises a bed 1 carrying printing frames 2 and adapted for movement so that the printing frames successively pass a cylinder 3 which carries the paper which is to be printed, with the paper preferably remaining in position on the cylinder while the latter makes a complete revolution during passage of each of the successive printing frames, so that the various frames operatively align with the paper on the cylinder in exactly the same relation for printing the various colors of multi-color work.

The bed 1 is preferably a horizontal annular bed carrying the printing frames in circumferentially spaced relation, with the cylinder 3 rotatable on a horizontal axis radially of the annular bed and adapted to make a plurality of complete revolutions at each complete rotation of the bed, so that with the bed and cylinder each continuously rotating in the same direction, a sheet of paper fed to the cylinder and remaining in position thereon throughout a plurality of complete revolutions of the cylinder, is successively printed by the circumferentially spaced printing frames and finally removed from the cylinder, with the operation then repeated as each successive sheet of paper is fed onto the cylinder.

The horizontal bed 1 is journaled by an annular bearing 4 on an upright frame 5 which preferably includes horizontal supporting surfaces 6—7 at the inner and outer peripheries of the annular bed; and the bed may be rotated by a pinion 8 meshing with a gear 9 at the underside of the bed, the pinion being journaled in brackets 10 carried by the frame 5 and having a worm driving connection 11 from a shaft 12 which may be rotated by a motor (not shown), and with a clutch 13 preferably provided between the worm drive and the pinion 8.

The printing frames 2 rest upon the bed 1 and are rotated therewith by links 15 which permit limited movement of the printing frames on the bed; and studs 16 depend from the respective ends of each printing frame at its outer edge and extend through slots 17 in the bed 1, with rollers 18 which are carried by the studs engaging an annular bearing surface or guide 19 which is carried by frame 5, so that when the bed 1 is rotated the printing frames are moved radially outwardly on the bed by centrifugal force, and are then rotated with the bed through the link connections 15, with circumferential movement of the printing frames guided by the contact of their rollers 18 with the bearing surface 19. Throughout the major portion of its length the

bearing surface 19 is a true circumference, but one part of its length is a chord of an arc of said circumference as shown at 19^a, so that during a portion of its rotation with bed 1, each of the frames 2 is guided along this chord by its rollers 18 engaging the bearing surface 19^a and by rollers 20 which also depend from studs 16 engaging a bearing surface 19^b. The bearing surface 19^b is carried by frame 5, parallel to but transversely spaced from bearing surface 19^a, so as to just permit passage of the rollers 18—20 between the cooperating bearing surfaces and thus insure accurate chordal movement of the printing frame with relation to the circumferentially moving bed, and the link connections 15 permit relative movement of the printing frame and bed so that the printing frame may move along the chord.

The cylinder 3 makes contact with the printing frames medially of their chordal movement, with the cylinder rotating on a horizontal axis at right angles to said chordal movement; and for this purpose the outer peripheral supporting surface 7 includes a segmental portion 7^a overlying the outer peripheral portion of bed 1 where the frames 2 are adapted for chordal movement, and the cylinder 3 is journaled in bearing brackets 22 which are mounted on the supporting surfaces 6—7^a. The cylinder rotates so that at the point of contact with a printing frame, the cylinder and frame are moving in the same direction; and rotation of the cylinder and chordal movement of the frame are synchronized so that while in contact the cylinder and frame move at exactly the same speed, and during each complete rotation of bed 1 the cylinder 3 makes one complete revolution as each of the printing frames moves past the cylinder, and preferably also makes one additional complete revolution while no printing frame is moving past the cylinder, and during which revolution the printed sheet is removed from the cylinder and a next succeeding sheet is fed to the cylinder.

It will thus be seen that the press may be built so as to print in any number of colors, the bed 1 being divided into a plurality of segments, one more than the number of colors desired, and a printing frame 2 for each color occupying succeeding segments so as to leave one blank segment, and the cylinder 3 making a complete revolution as each segment of the bed passes the same. The illustrated embodiment of the invention is adapted for two-color work, and the bed 1 is therefore divided into three segments, with printing frames A and B at two of the segments, leaving a blank segment C, and the cylinder 3 is adapted to make exactly three complete revolutions during each complete rotation of the bed.

The desired synchronized movement of the printing frames and cylinder may be obtained by driving the cylinder from the rotating bed, with the printing frames moved around to their chordal position and into alinement with the cylinder by rotation of the bed, and the cylinder then driving each printing frame along its chordal path while in printing contact with the cylinder.

As an instance of this arrangement an annular rack 25 may be provided at the outer periphery of bed 1, and a pinion 26 journaled in brackets 27 on the supporting surface 7^a may mesh with the rack through an opening 28 in the supporting surface. The cylinder 3 has an internal gear 29 driven by a pinion 30 which is journaled in a bracket 31 on supporting surface 7^a, and a

driving connection shown as a universal shaft 32 is provided between pinions 26 and 30. By proper gear ratios the cylinder 3 is thus adapted to make any desired number of complete revolutions for each complete rotation of bed 1. A rack 33 extends along the outer edge of each printing frame, and an external gear 34 on cylinder 3 meshes with the rack of each printing frame after the rotation of bed 1 has moved the printing frame around to its chordal position and has then moved the frame along its chordal path of travel into alinement with the cylinder.

The gear and rack driving connection 34—33 then continues the chordal movement of the printing frame during printing contact with the cylinder, so that the printing frame moves with the rotating cylinder and independently of bed 1, and the end of the link 15 which engages the bed has a slide 36 adapted for movement in a slot 37 which is formed in the bed, to permit such independent movement of the printing frame. After the printing operation and when the rack 33 has cleared the gear 34 and the rollers 18—20 have cleared the guide bearings 19^a—19^b, the printing frame is again moved with the rotating bed 1 by the rear end of slot 37 reengaging the slide 36, and the printing frame is thus swung from its chordal path of travel back to its circumferential path of travel with the rollers 18 engaging bearing surface 19 concentric with the bed. Movement of the slide 36 in slot 37 may be cushioned by a spring 38; and the link 15 may be accurately adjusted with relation to the slide by an eccentric take-up collar 39.

While the printing frames are moving around with the bed 1 so as to bring them to position ready for the printing operation, the printing surfaces 40 of the respective frames are selectively inked with their proper color; and for this purpose an inking pad 41 may be fixed on bed 1 in advance of each printing frame 2, with a series of inking rollers for each printing frame mounted above the bed and adapted to be inked by the corresponding inking pad passing under the series of rollers, which then in turn inks the printing surface of the corresponding printing frame when the latter passes under the series of rollers. As an instance of this arrangement series of rollers A' and B' are adapted to respectively ink the printing frames in segments A and B, and are preferably mounted on supporting surfaces 6—7 in circumferentially spaced relation so as to radially overlie and simultaneously contact their corresponding inking pads, and then simultaneously engage their corresponding printing frames as the rotating bed 1 moves the inking pads and printing frames past their corresponding rollers and then brings the inked printing frames into printing relation with cylinder 3.

Each series of inking rollers comprises a plurality of circumferentially spaced radial rods 42 journaled at their ends in bearings 43—44 which are mounted on supporting surfaces 6—7, and arms 45—46 are fixed on each rod 42 adjacent its ends and support a shaft 47 on which an inking roller is journaled. Each inking roller preferably comprises a plurality of rollers 48 longitudinally one beyond another, and each plurality of rollers is preferably yieldably held against movement along its shaft 47 by springs 49. Rotation of the inking rollers may thus substantially conform to movement of the corresponding inking pad 41 when the latter contacts the rollers; and the rollers are also adapted for yielding movement

relative to the printing surface which they engage when their corresponding printing frame moves past the rollers.

Each series of inking rollers is lowered into contact with its corresponding inking pad as the latter passes under the rollers, and is then elevated slightly so as to just make inking contact with its corresponding printing surface 40 as the latter then passes under the rollers, and is then further elevated so as to clear the printing frames and inking pads until the bed 1 has made a complete rotation, when the cycle of operation is repeated. For this purpose the arm 45 at the inner end of rod 42 has a depending guide bearing 50 journaled thereon, and these guide bearings for the inking rollers A'—B' respectively ride in annular grooves 52—53 which are formed in bed 1 adjacent its outer periphery. The base 51 of each annular groove has a depression 54 extending along a predetermined arc in radial alinement with its corresponding printing frame 2, and has a still further depression 55 extending along a predetermined arc in radial alinement with its corresponding inking pad 41.

Throughout the major portion of the rotation of bed 1 the guide bearings 50 thus ride on the bases 51 of their grooves 52—53, so as to rock the rods 42 for elevating the inking rollers A'—B' to inoperative position clear of both the printing frames and the inking pads, as shown at inking rollers A' in Figs. 1 and 5; but when one of the inking pads 41 alines with its corresponding inking rollers as shown at inking rollers B' in Figs. 1 and 5, the guide bearings 50 for said inking rollers ride in their corresponding depression 55 so as to rock the rods 42 for lowering the inking rollers into contact with their corresponding inking pad, thereby inking the rollers, and as the rotation of bed 1 continues so as to aline the corresponding printing frame with the inked rollers, the guide bearings 50 for said rollers ride in their corresponding depression 54 as shown at the left of the series of rollers B' in Fig. 5, so as to elevate the inked rollers to a position where the printing surface 40 of the printing frame passing under the rollers will just make contact with the inked rollers for inking the printing surface. After rotation of the bed 1 has moved the inked printing frame beyond its cooperating inking rollers, the guide bearings 50 for said rollers again ride on their corresponding base 51 so as to elevate the inking rollers to inoperative position. The various inking pads are adapted to ink the printing surfaces of their cooperating printing frames with the desired different colors; and after the printing frames have been inked they are successively moved along their chordal path of travel past the cylinder 3 which feeds the paper, it being noted that the supporting surface 7^a is spaced above the bed 1 as shown in Fig. 2 so as to permit unobstructed movement of the inking pads 41 under the surface 7^a as they are carried around with the bed 1, and it also being noted that the ends of the racks 33 on the printing frames as well as the upper ends of studs 16 are cut away as shown at 61, so that when the printing frames are moving along their circumferential path of travel prior to their chordal movement, the rollers 18 may engage the bearing surface 19 as shown in Fig. 6, without any portion of the printing frames striking the rack 25.

The printing frames which have had their printing surfaces properly inked are successively moved around to their chordal position by the links 15 and are then guided along their chordal

path of travel by the bearing surfaces 19^a—19^b, with the links 15 continuing to move the printing frames until the racks of the printing frames are engaged by the external gear on the cylinder 3. The printing frames are then moved with the cylinder throughout the printing engagement, with the slots 37 permitting relative movement of the printing frames and the bed, and after the printing operation the printing frames are again moved with the bed by the links 15 so as to complete the cycle of operation.

At the same time the cylinder 3 is revolved so as to make a complete revolution during the time that the segment C of the bed passes the cylinder, and any usual feed mechanism (not shown) is provided so as to feed a sheet of paper onto the cylinder during this revolution, with any usual gripping means (not shown) then holding the sheet of paper on the cylinder throughout the successive revolutions of the cylinder during which the printing frames are successively moved into printing relation with the cylinder for printing the sheet of paper in the various colors in exactly matched relation. After the printing operation is completed and during the time when the segment C again alines with the cylinder the printed sheet is removed in any usual manner (not shown), and at the same time a new sheet is fed onto the cylinder for repeating the printing operation during the next complete rotation of the bed.

I claim:

1. In a printing press, a movable bed, a printing frame on the bed, paper supporting means, a connection for moving the printing frame with the bed into alinement with the paper supporting means, and driving means distinct from said connection for moving the alined printing frame past the paper supporting means, the aforementioned connection permitting movement of the printing frame relative to the bed during and in the direction of movement of the printing frame past the paper supporting means.

2. In a printing press, a movable bed, a printing frame on the bed, a paper supporting cylinder, means for rotating the cylinder, a connection with moving the printing frame with the bed into alinement with the cylinder, and driving means distinct from said connection and actuated by the rotating cylinder for moving the alined printing frame past the cylinder, the aforementioned connection permitting movement of the printing frame relative to the bed during and in the direction of movement of the printing frame past the paper supporting cylinder.

3. In a printing press, an annular bed rotatable relative to its axis, means for rotating the bed, a printing frame on the bed, paper supporting means, a connection for moving the printing frame with the rotating bed into alinement with the paper supporting means, and driving means distinct from said connection for moving the alined printing frame past the paper supporting means, the aforementioned connection permitting movement of the printing frame relative to the bed during and in the direction of movement of the printing frame past the paper supporting means.

4. In a printing press, a movable bed, a printing frame on the bed, a paper supporting cylinder, means for rotating the cylinder, a connection for moving the printing frame with the bed into alinement with the cylinder, a rack on the printing frame, and a gear on the rotat-

ing cylinder adapted to mesh with the rack for moving the aligned printing frame past the cylinder, the aforementioned connection permitting movement of the printing frame relative to the bed during and in the direction of movement of the printing frame past the paper supporting cylinder.

5. In a printing press, an annular bed rotatable relative to its axis, a printing frame on the bed, a shaft radially overlying the rotatable annular bed, a plurality of inking rollers journaled on the shaft independently of one another, and means for moving the printing frame with the rotatable annular bed for contact of the printing frame by the inking rollers and sub-

sequent movement of the inked printing frame past a printing point.

6. In a printing press, an annular bed rotatable relative to its axis, a printing frame on the bed, a shaft radially overlying the rotatable annular bed, an inking roller journaled on the shaft, tensioning means yieldably holding the roller against movement longitudinally of the shaft, and means for moving the printing frame with the rotatable annular bed for contact of the printing frame by the inking roller and subsequent movement of the inked printing frame past a printing point.

JAMES A. WRAY. 15