

A. V. H. OLIVER.  
Wagon Brake.

No. 110,673.

Patented Jan. 3, 1871.

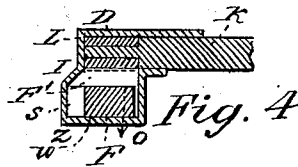
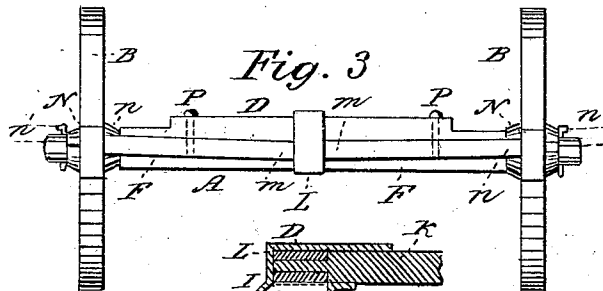
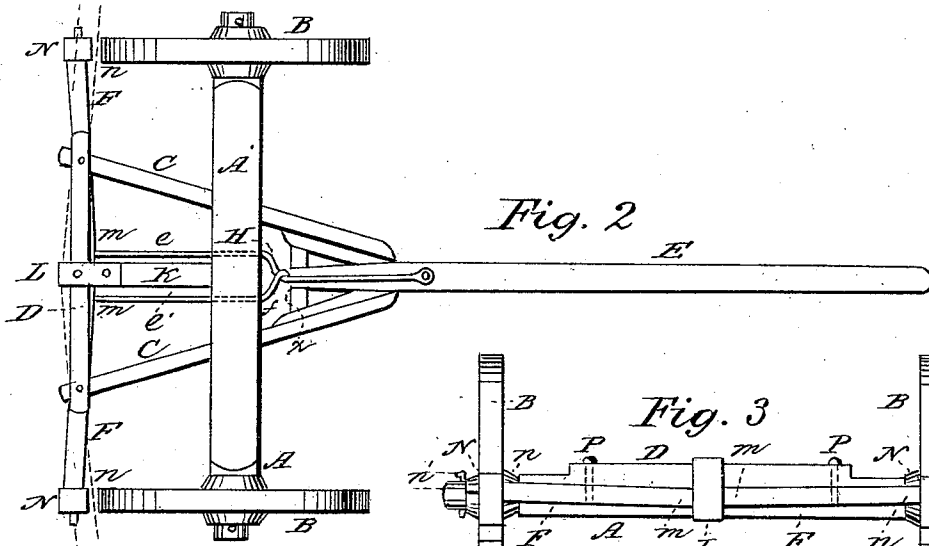
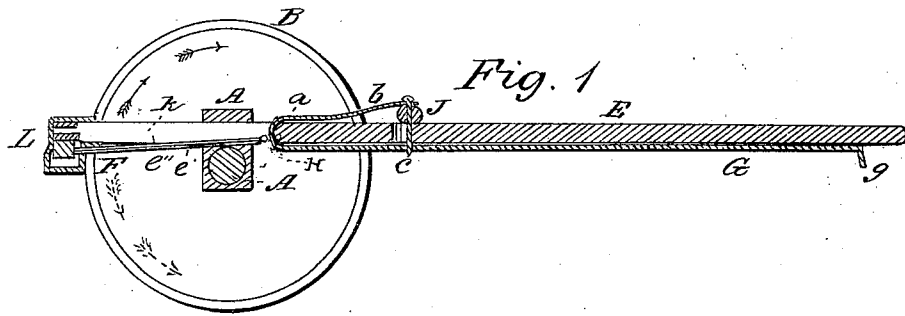

Witnesses:  
Alex Selkirk  
M. Hyde

Inventor:  
Andrew V. H. Oliver

# United States Patent Office.

ANDREW VAN DER HYDEN OLIVER, OF BETHLEHEM, NEW YORK.

Letters Patent No. 110,673, dated January 3, 1871.

## IMPROVEMENT IN WAGON-BRAKES.

The Schedule referred to in these Letters Patent and making part of the same.

To all whom it may concern:

Be it known that I, ANDREW VAN DER HYDEN OLIVER, of the town of Bethlehem, county of Albany, State of New York, have invented certain new and useful Improvements in Wagon-Brakes; and I do hereby declare that the following is a description thereof, reference being had to the accompanying drawing forming a part of this specification, in which—

Figure 1 is a side elevation of the front part of a wagon with the improvements in this invention applied.

Figure 2 is a vertical view from above of the same.

Figure 3 is a view from the rear of the fore part of a wagon with this invention applied.

Figure 4 is a cross-section, on an enlarged scale, of the brake-bar guard used with this invention.

The same letters indicate like or similar parts.

In the drawing—

A represents the axle.

B B are the wheels.

C C are the hounds.

D is the sway-bar.

E, the pole.

F F are the brake-levers.

I place beneath the pole E a backing-rod, G, fig. 1, which rod is furnished with the usual holdback *g*, by which the said rod is pushed back.

The rear end of the backing-rod is furnished with a loop, *a*, which is formed by continuing the backing-rod G up past the rear end of the pole E, as shown in fig. 1.

The said rod is continued past the loop *a*, and is extended over the top of the rear end of the pole, and in such a manner that the said extended part will form the hammer-strap *b*, figs. 1 and 2.

The said hammer-strap *b* is furnished with the usual hole to receive the bolt of the double-tree J, which bolt passes down into and works in the oblong hole *c*, made in the pole at that point, as shown in figs. 1 and 2.

By this combination of the several parts described above, the horses, by their backing, will effect the several other parts of the brake to cause the brake-blocks to operate on the wheels, and by their draft will also effect the reverse, and release the said brake-shoes from contact with the wheels.

H is a forked rod having two legs, *e* and *e'*, connecting with a common head, *f*, in front of the axle A, which head is provided with an eye, X, through which the loop *a* of the backing-rod G is passed, as shown in figs. 1 and 2.

The legs *e* and *e'* are passed through the space between the axle A and the sand-bar A', and con-

nect with the levers F F at near their contacting ends.

Being thus constructed and arranged, this forked rod H, connecting with the backing-rod G and the levers F F, will operate the said levers F F to throw the brake-shoes in action when the said backing-rod G is crowded back; but when the said forked rod H is drawn forward by the action of the draft of the horses on the double-tree through the backing-rod G, the said levers F F will be thrown the reverse, so as to throw the brake-shoes out of action with the wheels.

The brake-levers F F are pivoted below the sway-bar D and the hounds C, as shown in the several figures, and in such a manner that a permission will be given for vertical movement of their ends *m* and *n* on each side of the pivots *p*, fig. 3.

At the center of the sway-bar D, where the reach-head K connects with the same, I place a piece, L, which I denominate the lever-guard, which guard consists of a wide piece of metal, which I form, as shown in figs. 1, 2, and 4, in such a manner as will leave a space between the sway-bar D and the bottom of the guard L sufficient to admit the thickness of the levers F F, and at the same time retain a vacant space in which the ends of the said levers F can work vertically. The said guard has in it also a recess, S, at its rear, in which the ends of the levers can play.

When descending a hill, the horses will hold back by neck-yoke pressing against the holdback *g* of the backing-rod G, which rod will throw the forked rod H back and cause the ends *m* of the levers F F to throw back, as shown in fig. 2 by dotted lines. When the said ends *m* are thrown back, the levers F will swing on their pivots *p*, and will throw the ends *n* forward so as carry the brake-shoes N in contact with the wheels A. The wheels A, revolving forward in the direction indicated by full-line arrows, will, by the friction consequent by the contact of shoes N with the said wheels, tend to carry the end *n* up to dotted line *n'*, fig. 3, when the ends *m* will be thrown down, and the horses holding back will tend to crowd the said ends *m* back into the recess S, fig. 4, so that the said lever-ends *m* will occupy the space between Z V instead of between *n* *o'*. The bottom of the guard L will in the meantime hold up the ends *m*, and prevent their being thrown unduly down.

But when the wheels are revolved back in a direction indicated by dotted arrows in fig. 1, as in the case with backing from under a shed, the contact of the wheels A with the shoes N will tend to carry the ends *n* down and throw up the ends *m* to the lower side of the sway-bar, as shown by dotted lines F' in fig. 4, when the ends *m* will catch at the point just above

the recess S, prevent the said ends to throw back, and will thus prevent the ends *a* being excessively pressed toward the wheels A, and prevent the shoes N from acting effectively on the said wheels.

Having described my invention,

What I claim, and desire to secure by Letters Patent, is—

1. In a wagon-brake, the loop *a* and hammer-strap *b*, combined with the backing-rod G, substantially as and for the purpose set forth.

2. The forked lever-rod H with its eye *x*, combined with the brake-lever D and backing-rod G, when all are constructed and operated as described.

3. The guard L, constructed substantially as and for the purpose set forth.

ANDREW V. D. H. OLIVER.

Witnesses:

ALEX. SELKIRK,  
M. F. HYDE.