



- (51) **International Patent Classification:**
F24H 1/18 (2006.01) F24D 17/00 (2006.01)
F24H 1/10 (2006.01)
- (21) **International Application Number:**
PCT/SG2015/050179
- (22) **International Filing Date:**
24 June 2015 (24.06.2015)
- (25) **Filing Language:** English
- (26) **Publication Language:** English
- (30) **Priority Data:**
10201403590U 25 June 2014 (25.06.2014) SG
- (71) **Applicants:** FRESHTECH TECHNOLOGY [SG/SG];
51 Bukit Batok Crescent, #07-41 Unity Centre, Singapore
658077 (SG). KOH, Kok Hua [SG/SG]; Block 73 Marine,
Drive #13-51, Singapore 440073 (SG).
- (72) **Inventor:** LIM, Kim San; 671, Woodlands Drive 71, #02-
49, Singapore 730671 (SG).
- (74) **Agent:** VIERING, JENTSCHURA & PARTNER LLP;
P.O. Box 1088, Rochor Post Office, Rochor Road, Singa-
pore 911833 (SG).

- (81) **Designated States** (unless otherwise indicated, for every kind of national protection available): AE, AG, AL, AM, AO, AT, AU, AZ, BA, BB, BG, BH, BN, BR, BW, BY, BZ, CA, CH, CL, CN, CO, CR, CU, CZ, DE, DK, DM, DO, DZ, EC, EE, EG, ES, FI, GB, GD, GE, GH, GM, GT, HN, HR, HU, ID, IL, IN, IR, IS, JP, KE, KG, KN, KP, KR, KZ, LA, LC, LK, LR, LS, LU, LY, MA, MD, ME, MG, MK, MN, MW, MX, MY, MZ, NA, NG, NI, NO, NZ, OM, PA, PE, PG, PH, PL, PT, QA, RO, RS, RU, RW, SA, SC, SD, SE, SG, SK, SL, SM, ST, SV, SY, TH, TJ, TM, TN, TR, TT, TZ, UA, UG, US, UZ, VC, VN, ZA, ZM, ZW.
- (84) **Designated States** (unless otherwise indicated, for every kind of regional protection available): ARIPO (BW, GH, GM, KE, LR, LS, MW, MZ, NA, RW, SD, SL, ST, SZ, TZ, UG, ZM, ZW), Eurasian (AM, AZ, BY, KG, KZ, RU, TJ, TM), European (AL, AT, BE, BG, CH, CY, CZ, DE, DK, EE, ES, FI, FR, GB, GR, HR, HU, IE, IS, IT, LT, LU, LV, MC, MK, MT, NL, NO, PL, PT, RO, RS, SE, SI, SK, SM, TR), OAPI (BF, BJ, CF, CG, CI, CM, GA, GN, GQ, GW, KM, ML, MR, NE, SN, TD, TG).

Published:
— with international search report (Art. 21(3))

(54) **Title:** A HEATED LIQUID SUPPLY SYSTEM AND A METHOD OF HEATING LIQUID

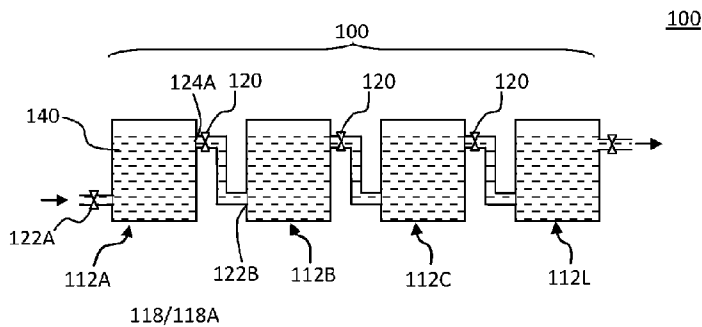
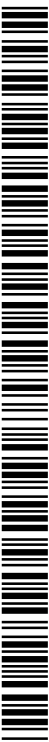

Fig. 1

(57) **Abstract:** The present invention provides a heated liquid supply system having a plurality of heating compartments, each heating compartment of the plurality of heating compartments being fluidly connected to another heating compartment of the plurality of heating compartments. Each heating compartment is adapted to contain a volume of liquid therein and heat the volume of liquid to a pre-determined temperature for said each heating compartment. Each heating compartment of the plurality of heating compartments is adapted to receive a volume of supply liquid at a pre-determined flow rate, and discharge a volume of heated liquid into an adjacent fluidly connected heating compartment, such that each heating compartment of the plurality of compartments is adapted to heat each volume of supply liquid entering said each heating compartment when the temperature of each volume of supply liquid is below the pre-determined temperature of said each heating compartment. The present invention further provides a method of heating liquid with the heated liquid supply system.



A HEATED LIQUID SUPPLY SYSTEM AND A METHOD OF HEATING LIQUID**Cross-Reference To Related Application**

[0001] This application claims the benefit of priority of Singapore patent application No. 10201403590U, filed 25 June 2014, the content of it being hereby incorporated by reference in its entirety for all purposes.

Technical Field

[0002] The present invention relates to a heated liquid supply system, for example, a heated liquid supply system adapted to heat a building liquid supply system.

Background

[0003] Buildings, e.g. hotels, office buildings, may require a heated liquid supply system to provide heated liquid for some of the essential facilities, e.g. absorption chiller, hot liquid supply, air handling unit (AHU).

[0004] Conventional liquid heating systems may be to heat the liquid. For example, a condensing boiler may be used to boil liquid for buildings. Heating liquid for buildings requires a large amount of heat energy and therefore can be very energy consuming, i.e. consume a substantial amount of fuel. There have been many innovations made to improve the heating efficiency of heaters, for example, a condensing boiler makes use of heated gas to pre-heat liquid before entering the boilers.

[0005] Although the technology and heating efficiency of liquid heating systems have improved over the years, there remain some disadvantages in the conventional liquid heating systems.

[0006] For example, the time required to heat up a large quantity of liquid over a temperature interval may be relatively long. Furthermore, the amount of liquid heated may not be able to meet the demand of heated liquid. In the event that the amount of heated liquid falls short of the demand, more liquid has to be heated and a lapse in the supply of heated liquid may occur. The lack of heated liquid supply may result in a temporary malfunction of the essential facilities and cause discomfort and inconvenience to the tenants in the buildings. In the event that the amount of heated liquid supply is much higher than the

demand, there may be excess heated liquid left unused and the energy used to heat up the excess amount of liquid is wasted.

[0007] Therefore, it is necessary to have a liquid heating system that is adapted able to overcome the above disadvantages.

Summary

[0008] According to various embodiments of the present invention, a heated liquid supply system is provided. The heated liquid supply system has a plurality of heating compartments, each heating compartment of the plurality of heating compartments being fluidly connected to another heating compartment of the plurality of heating compartments. Each heating compartment is adapted to contain a volume of liquid therein and heat the volume of liquid to a pre-determined temperature for said each heating compartment. Each heating compartment of the plurality of heating compartments is adapted to receive a volume of supply liquid at a pre-determined flow rate, and discharge a volume of heated liquid into an adjacent fluidly connected heating compartment, such that each heating compartment of the plurality of compartments is adapted to heat each volume of supply liquid entering said each heating compartment when the temperature of each volume of supply liquid is below the pre-determined temperature of said each heating compartment. A first heating compartment of the plurality of heating compartments is adapted to receive a volume of supply liquid to be heated up and a last heating compartment of the plurality of heating compartments is adapted to discharge the volume of heated supply liquid to be supplied.

[0009] According to various embodiments, the plurality of heating compartments may be sequentially connected to each other.

[0010] According to various embodiments, the pre-determined temperature of a heating compartment of the plurality of heating compartments may be the same as or different from the pre-determined temperature of another heating compartment.

[0011] According to various embodiments, the pre-determined temperature of a heating compartment of the plurality of heating compartments is higher than the pre-determined temperature of another heating compartment downstream the heating compartment.

[0012] According to various embodiments, the plurality of heating compartments are thermally insulated from each other.

[0013] According to various embodiments, each heating compartment of the plurality of compartments comprises an inlet, an outlet spaced from the inlet, a heating element at about the inlet, said heating element adapted to heat the volume of liquid that has entered each heating compartment via the inlet when the temperature of the volume of liquid is lower than the pre-determined temperature of the heating compartment.

[0014] According to various embodiments, the heating element is disposed between the inlet and the outlet.

[0015] According to various embodiments, each heating compartment of the first plurality of heating compartment is a heating tank.

[0016] According to various embodiments, the heated liquid supply system further includes a further plurality of heating compartments according to the plurality of heating compartments in any one of claims 1 to 8, wherein the further plurality of heating compartments are fluidly connected to the plurality of heating compartments.

[0017] According to various embodiments, a first heating compartment of the further plurality of heating compartments is fluidly connected to the last heating compartment of the plurality of heating compartments such that the plurality of heating compartments is adapted to channel the volume of heated supply liquid or a portion thereof into the first heating compartment of the further plurality of heating compartments.

[0018] According to various embodiments, the first heating compartment of the further plurality of heating compartments is adapted to receive a volume of supply liquid.

[0019] According to various embodiments, the heated liquid supply system further includes a control system configured to control the heating process of the heated liquid supply system, the control system comprising a central processing unit, wherein the central processing unit is in communication with each heating compartment of the plurality of heating compartments.

[0020] According to various embodiments, the control system comprises a heat sensing module in communication with the central processing unit, the heat sensing module being in communication with the heat sensor of each heating compartment

[0021] According to various embodiments, the control system comprises a heating module in communication with the central processing unit, the heating module being in communication with the heating element of each heating compartment.

[0022] According to various embodiments, a method of heating liquid with a heated liquid supply system is provided. The method includes heating the volume of liquid within each heating compartment of the plurality of heating compartments to a pre-determined temperature determined for each heating compartment of the plurality of heating compartments; receiving a volume of supply liquid into the first heating compartment of the plurality of heating compartments and heating the volume of supply liquid; discharging the volume of heated liquid from the first heating compartment of the plurality of heating compartments into the adjacent fluidly connected heating compartment of the plurality of heating compartments; heating each volume of supply liquid that entered each heating compartment of the plurality of heating compartments to the pre-determined temperature of the each heating compartment when the temperature of each volume of supply liquid is below the pre-determined temperature of said each heating compartment; and discharging the volume of heated supply liquid from the last heating compartment of the first plurality of heating compartments.

[0023] According to various embodiments, the method further includes heating a volume of liquid within each heating compartment of the further plurality of heating compartments; and channelling the volume of heated supply liquid from the plurality of heating compartments into the first compartment of the further plurality of heating compartments.

Brief Description of Drawings

[0024] Fig. 1 shows a schematic view of a heated liquid supply system;

[0025] Fig. 2 shows a schematic view of a heating compartment of the heated liquid supply system in Fig. 1;

[0026] Fig. 3 shows a schematic view of another configuration of the heated liquid supply system in Fig. 1;

[0027] Fig. 4 shows a schematic view of a control system of the heated liquid supply system in Fig. 1;

[0028] Fig. 5 shows a method of heating liquid using the heated liquid supply system of Fig. 1;

[0029] Fig. 6 shows a schematic view of a group of heating compartments of the heated liquid supply system in Fig. 1;

[0030] Fig. 7 shows a schematic view of another exemplary configuration of the heated liquid supply system in Fig. 1;

[0031] Fig. 8 shows a schematic view of another exemplary configuration of the heated liquid supply system in Fig. 1;

[0032] Fig. 9 shows a schematic view of another exemplary configuration of the heated liquid supply system in Fig. 1;

[0033] Fig. 10 shows a schematic view of another exemplary configuration of the heated liquid supply system in Fig. 1;

[0034] Fig. 11 shows a schematic view of another exemplary configuration of the heated liquid supply system in Fig. 1;

[0035] Fig. 12 shows a schematic view of another exemplary configuration of the heated liquid supply system in Fig. 1;

[0036] Fig. 13 shows a schematic view of another exemplary configuration of the heated liquid supply system in Fig. 1;

[0037] Fig. 14 shows a schematic view of another exemplary configuration of the heated liquid supply system in Fig. 1;

[0038] Fig. 15 shows a schematic view of another exemplary configuration of the heated liquid supply system in Fig. 1; and

[0039] Fig. 16 shows a flow diagram of a building heating/cooling system using the heated liquid supply system in Fig. 1.

Detailed Description

[0040] Fig. 1 shows a heated liquid supply system 100 having a plurality of heating compartments 110. Each heating compartment 112 of the plurality of heating compartments 110 is fluidly connected to another heating compartment 112 of the plurality of heating compartments 110. Each heating compartment 112 is adapted to contain a volume of liquid therein and heat the volume of liquid to a pre-determined temperature for said each heating compartment 112. Each heating compartment 112 of the plurality of heating compartments 110 is adapted to receive a volume of supply liquid at a pre-determined flow rate, and discharge a volume of heated liquid 144 into an adjacent fluidly connected heating compartment 112. Each heating compartment 112 of the plurality of compartments 110 is adapted to heat each volume of supply liquid entering said each heating compartment 112 when the temperature of each volume of supply liquid is below the pre-determined temperature of said each heating compartment 112. A first heating compartment 112A of the plurality of heating compartments is adapted to receive a volume of supply liquid to be heated up and a last heating compartment 112L of the plurality of heating compartments is adapted to discharge the volume of heated supply liquid to be supplied.

[0041] As shown in Fig. 1, the plurality of heating compartments 110 may be sequentially connected to each other. In other words, the plurality of heating compartments 110 may be arranged in series. Each of the heating compartments 112 may be fluidly connected to another heating compartment 112. Each of the heating compartments 112 may be connected to another heating compartment 112 via a conduit 118. Conduit 118 may include at least one valve 120 adapted to control the flow of fluid along the conduit 118. As shown in Fig. 1, first heating compartment 112A may be connected to an adjacent heating compartment 112B, heating compartment 112B may be connected to an adjacent heating compartment 112C, so on and so forth. First heating compartment 112A may be a heating compartment 112 which is connected to only one other heating compartment 112 and may be the heating compartment which receives a volume of liquid supply from a source external of the heated water liquid system 100. Fluid may flow from the first heating compartment 112A to the last heating compartment 112L in a downstream direction. Any one of the each heating

compartment 112, other than the first heating compartment 112A, may be the last heating compartment 112L. Last heating compartment 112L may be a heating compartment 112 which is connected to only one other heating compartment 112 and may be the heating compartment which discharges a volume of heated liquid out of the heated liquid supply system 100. Although there are only four heating compartments 112 shown in Fig. 1, it is clear that there can be more than four heating compartments 112 in the plurality of heating compartments 112, e.g. more than 10, 15, 20 etc. Liquid in the system may be water.

[0042] Referring to Fig. 2, each heating compartment 112 may include a housing 130 having a first end 132, a second end 134 opposite the first end 132 and a circumferential wall 136 extending from the first end 132 to the second end 132 along a longitudinal axis 138. Housing 130 may be a cylinder whereby a section of the cylinder along a plane substantially perpendicular to the longitudinal axis 138 is circular. Housing 130 may be an oblong whereby the section may be square, rectangle etc. Each heating compartment 112 of the plurality of compartments 110 may include an inlet 122, an outlet 124 spaced from the inlet. Inlet 122 may be disposed along the circumferential wall 136, the inlet 122 being adapted to allow fluid flow into the heating compartment 112. Outlet 124 may be disposed along the circumferential wall 136, the outlet 124 being adapted to allow fluid flow out of the heating compartment 112. Inlet 122 may be disposed at about a bottom portion 126 of the heating compartment 112. Outlet 124 may be disposed at about a top portion 128 of the heating compartment 112. Top portion 128 may be spaced from the bottom portion 126. As shown in Fig. 2, top portion 128 may be above the bottom portion 126 such that the outlet 124 may be above the inlet 122. Top portion 128 and bottom portion 126 may be away from the first end 132 and second end 134 respectively. Bottom portion 126 may be at about the first end 132. Top portion 128 may be at about the second end 134. Outlet 124 may be disposed diagonally across the inlet 122 along the circumferential wall 136 such that fluid may flow into each heating compartment 112 on one side of the housing 130 and exit said heating compartment 112 on another side of the housing 130 opposite the one side. Outlet 124 may be on the same side of the circumferential wall 136 as the inlet 122.

[0043] Referring to Fig. 1, outlet 124 of first heating compartment 112 may be fluidly connected to the inlet 122 of another heating compartment 112. For example, outlet 124A of the heating compartment 112A may be fluidly connected to the inlet 122B of the heating compartment 112B. Outlet 124A may be fluidly connected to conduit 118 at a first end of

the conduit 118 and the inlet 122B of the heating compartment 112B may be fluidly connected to the conduit 118 at a second end of the conduit 118. At least one valve 120 may be disposed between the first end and the second end of the conduit 118.

[0044] Referring to Fig. 1, first heating compartment 112A may receive a volume of supply liquid at a pre-determined flow rate. As the first heating compartment 112A may be filled with the volume of liquid 140, the volume of supply liquid entering the first heating compartment 112A may force the same volume of liquid out of the first heating compartment 112A via outlet 124A. Consequently, as heating compartment 112B is fluidly connected to the first heating compartment 112A, the same volume of liquid may flow into the heating compartment 112B via the conduit 118A. Accordingly, liquid flow between the plurality of heating compartments 110 may flow at the same flow rate. Consequently, the volume of heated liquid from the last heating compartment 112L may be supplied at the same flow rate. Heated liquid supply system 100 may include a flow rate meter (not shown in Fig. 1) to measure the flow rate of the liquid through the plurality of heating compartments 112.

[0045] Each heating compartment 112 may be thermally insulated to prevent heat loss to the surrounding. As such, the plurality of heating compartments may be thermally insulated from each other. Each heating compartment 112 may include a thermal layer surrounding the housing 130.

[0046] Referring to Fig. 2, each heating compartment 112 may include an inlet valve 162 connected to the inlet 122. Inlet valve 162 may be adapted to control the flow of liquid into the heating compartment 112. Each heating compartment 112 may include an outlet valve 164 connected to the outlet 124. Outlet valve 164 may be adapted to control the flow of liquid out of the heating compartment 112. Accordingly, there may be two valves, inlet valve 162 and outlet valve 164, between two adjacent heating compartments 112. Inlet valve 162 and/or outlet valve 164 may be motorised valves.

[0047] Each heating compartment may include a heating element 150 at about the inlet 122 within the housing 130 of each heating compartment 112. Heating element 150 may be adapted to heat a volume of liquid that has entered each heating compartment 112 via the inlet 122 when the temperature of the volume of liquid is lower than the pre-determined temperature of the heating compartment. Heating element 150 may be turned on when

required. Referring to Fig. 2, heating element may be disposed between the inlet 122 and the outlet 124. Heating element 150 may be disposed between inlet 122 and first end 132 of the heating compartment. Heating element 150 may be a coiled heating element, a ceramic heating plate, or any heating element known to a person skilled in the art that is capable of providing the heating capacity for the present purpose, heating volume of liquid, particularly for building heating liquid system.

[0048] Each heating compartment 112 may be adapted to heat the volume of liquid within the each heating compartment 112 to a pre-determined temperature. The pre-determined temperature of a heating compartment 112 of the plurality of heating compartments 110 may be the same as or different from the pre-determined temperature of another heating compartment 112. The temperature of the volume of liquid in each heating compartment 112, e.g. 112A, 112B, 112C, of the plurality of heating compartment 110 may be heated to the same temperature. The temperature of volume of liquid in one heating compartment 112 may be heated to a temperature which is different from the temperature of volume of liquid in another heating compartment 112. The pre-determined temperature of a heating compartment 112, e.g. the first heating compartment 112A, of the plurality of heating compartments 110 may be higher than the pre-determined temperature of another heating compartment, e.g. heating compartment 112B, downstream the heating compartment 112. For example, the temperature of the volume of liquid in the heating compartment 112A, may be heated to a temperature, e.g. 90°C, higher than the temperature of the volume of liquid in another heating compartment 112, e.g. 80°C heating compartment 112B. The pre-determined temperature of a heating compartment 112, e.g. first heating compartment 112A, of the plurality of heating compartments 110 may be lower than the pre-determined temperature of another heating compartment, e.g. heating compartment 112B, downstream the heating compartment 112. For example, the temperature of the volume of liquid in the first heating compartment 112A, may be heated to a temperature lower than the temperature of the volume of liquid in another heating compartment 112, e.g. 70°C in heating compartment 112B.

[0049] Each heating compartment 112 may be turned on to heat the volume of liquid within or turned off to stop the heating. Each heating compartment 112 may be turned on when the temperature of the volume of supply liquid through the inlet 122 of the heating compartment 112 is lower than the predetermined temperature set for the heating compartment.

[0050] Heating compartment 112 may include a heat sensor 114, e.g. a thermostat, to detect the temperature of the volume of liquid in the heating compartment 112. The heat sensor 114 or another heat sensor may be used to detect the temperature of the volume of supply liquid entering the heating compartment 112. If the temperature of the volume of supply liquid is lower than the pre-determined temperature set for the heating compartment 112, the heating element 150 may be turned on to heat the incoming volume of liquid to the pre-determined temperature.

[0051] Each heating compartment of the first plurality of heating compartment may be a heating tank.

[0052] Heated supply liquid 144 may be channelled out of the last heating compartment 112L to be supplied to facilities, e.g. absorption chiller, domestic hot liquid circuit of the building. At times, the amount of heated supply liquid 144 may be more than its demand. In such cases, the excess heated supply liquid 144 may be channelled back into the heated liquid supply system 100.

[0053] Referring to Fig. 3, heated liquid supply system 101 may include a return conduit 152 connected to the first heating compartment 112A and to the last heating compartment 112L. First heating compartment 112A may include a return inlet 154 such that first heating compartment 112A may be in fluid communication with return conduit 152 via the return inlet 154. Return conduit 152 may be fluidly connected to the return inlet 154 of the first heating compartment 112A at one end of return conduit 152. Return conduit 152 may be fluidly connected to the outlet 122L of the last heating compartment 112L at the other end of return conduit 152. Last heating compartment 112L may include a return outlet (not shown in Fig. 3) such that the return conduit 152 may be connected to the last heating compartment 112L via the return outlet. A volume of heated liquid may be channelled from the last heating compartment 112L to the first heating compartment 112A via the return conduit 152. For a plurality of heating compartments 110 with descending pre-determined temperatures from the first heating compartment 112A to the last heating compartment 112L, by channelling excess heater liquid from the last heating compartment 112L back to the first heating compartment 112L, the amount of heat energy required to heat the volume of heated liquid from the pre-determined temperature of the last heating compartment 112L (e.g. 60°C) to that of the first heating compartment 112A (e.g. 90°C) may be lesser than the

amount of heat energy required to heat a volume of supply liquid at room temperature (e.g. 27°C) to the pre-determined temperature of the first heating compartment 112A (e.g. 90°C).

[0054] Referring to Fig. 4, heated liquid supply system 100 may include a control system 170 for controlling the heating process of the heated liquid supply system 100. Control system 170 may include a central processing unit 180. Central processing unit 180 may be in communication with each of the plurality of heating compartments 112.

[0055] Control system 170 may include a heat sensing module 182 in communication with the central processing unit 180. Heat sensing module 182 may be in communication with the heat sensors 114 of each heating compartments 112.

[0056] Control system 170 may include a heating module 184 in communication with the central processing unit 180. Heating module 184 may be in communication with the heating element 150 of each heating compartment 112.

[0057] Central processing unit 180 may be configured to receive thermal signal from each of the heat sensors 114 for sensing the temperature of the volume of supply liquid entering each heating compartment 112. Central processing unit 180 may be configured to transmit a heating signal to each of the heating elements 150 to heat the volume of supply liquid when necessary.

[0058] Control system 170 may include a valve control module 186 in communication with central processing unit 180. Valve control unit 186 may be in communication with the inlet valves 162 and/or the outlet valves 164. Valve control unit 186 may be configured to control the inlet valves 162 and/or the outlet valves 164. Central processing unit 180 may be configured to transmit a valve signal to each of the inlet valves 162 and/or outlet valves 164 to control the flow of liquid into and out of the heating compartments 112.

[0059] Control system 170 may include a pump control module 188 in communication with central processing unit 180. Pump control module 188 may be in communication with a pump so as to activate the pump when necessary to pump a volume of supply liquid into the first heating compartment 112A. Central processing unit 180 may transmit a pump signal to pump to activate the pump.

[0060] Control system 170 may include an input system 190 in communication with a central processing unit 180. Input system 190 may have an input interface 192 for receiving user requirements. Upon receipt of the user requirements, input system 190 may transmit input signals to central process unit 180. Central processing unit 180, upon receiving the input signals may compute the pre-determined temperature of each of the plurality of heating compartments 110 and the flow rate required by the plurality of heating compartments 110. Central processing unit 180 may transmit the heating signal to the heating element 150 in each heating compartment 112 to heat the volume of liquid therein to the pre-determined temperature for each heating compartment 112. Central processing unit 180 may transmit a pump signal to the pump to pump liquid into the first heating compartment 112A at the pre-determined flow rate. Central processing unit 180 may transmit valve signals to each of the inlet valves 162 and outlet valves 164 to open the relevant valves.

[0061] Fig. 5 shows a method 1000 of heating liquid with the heated liquid supply system 100. Method 1000 includes step 1100 of heating the volume of liquid within each heating compartment 112 of the plurality of heating compartments 110 to a pre-determined temperature determined for each heating compartment 112 of the plurality of heating compartments 110. In step 1200, the volume of supply liquid is received into the first heating compartment 112A of the plurality of heating compartments 110 and the volume of supply liquid is being heated. In step 1300, the volume of heated liquid is channelled from the first heating compartment 112A of the plurality of heating compartments 110 into the adjacent fluidly connected heating compartment, e.g. 112B, of the plurality of heating compartments 110. As shown in step 1400, each volume of supply liquid that entered each heating compartment 112 of the plurality of heating compartments 110 is being heated to the pre-determined temperature of the each heating compartment 112 when the temperature of each volume of supply liquid is below the pre-determined temperature of said each heating compartment 112. In step 1500, the volume of heated supply liquid 144 is being supplied from the last heating compartment 112L of the first plurality of heating compartments 110.

[0062] Referring to Fig. 3, each of the plurality of heating compartments 110, which includes the first heating compartment 112A, may contain a volume of liquid. The volume of liquid within each compartment 112 may be heated to a pre-determined temperature for the heating compartment. A volume of supply liquid may be channelled into the first heating

compartment 112A via the inlet 112A. Typically, the volume of supply liquid may be at room or surrounding temperature, e.g. 27°C. As the volume of supply liquid enters the first heating compartment 112A via inlet 112A, the temperature of the volume of supply liquid may be determined. Heat sensor 114 may be used to detect the temperature of the volume of supply liquid. If the pre-determined temperature of the first heating compartment 112A (e.g. 90°C) is higher than the temperature of the volume of supply liquid, the heating element 150 may be turned on to heat the incoming volume of liquid to the pre-determined temperature. As the volume of supply liquid enters the first heating compartment 112A, an equivalent of amount of liquid is 'pushed out' of the first heating compartment 112A and into the adjacent heating compartment, e.g. 112B.

[0063] The volume of supply liquid may be pumped into the plurality of heating compartments 110 by a pump (not shown in Fig. 3) at a flow rate. The flow rate may be determined by factors including the heating capacity of the heated liquid supply system and demand of heated liquid.

[0064] In an example, a user may input user requirement via input interface 192 into central processing system 180. Based on the user requirements, the pre-determined temperature of each of the heating compartments 112 may be determined. In addition, flow rate of the volume of supply liquid may be determined. Heating signals may be transmitted to the heating elements in each of the heating compartments to heat the volume of liquid therein to the pre-determined temperature. Central processing unit 180 may receive thermal signals from the heat sensors and transmit heating signals to the heating elements to cease heating when the pre-determined temperature is reached. For example, first heating compartment 112A and heating compartments 112B, 112C, 112D may be heated to a pre-determined temperature of 90°C, 85°C and 80°C respectively.

[0065] A pump signal may be transmitted to the pump to inject a volume of supply liquid at a pre-determined flow rate. The volume of supply liquid may be at 27°C. The volume of supply liquid entering first heating compartment 112A may be heated to 90°C. A substantially equivalent volume of heated liquid at 90°C may flow out of the first heating compartment 112A and into the adjacent heating compartment 112B. Heat sensor 114B (not shown in Fig. 3) in heating compartment 112B may sense the temperature of the heated liquid and transmit the thermal signal to the central processing system 180. Central

processing system 180 may compute the thermal signal and recognise that the temperature of the volume of liquid in heating compartment 112B (i.e. 85°C) is lower than the temperature of the incoming heated liquid (i.e. 90°C). The central processing system 180 may send a heating signal to cease the heating element 150 in the heating compartment 112B or may not send a heating signal to turn on the heating element 150 if the heating element 150 is not already turned on. Similarly, a substantially equivalent volume of heated liquid may exit the heating compartment 112B via its outlet 124 and enters heating compartment 112C via inlet 122 of heating compartment 112C. Similarly, the central processing system 180 may receive thermal signals from the heating sensor 114C (not shown in Fig. 3) in heating compartment 112C and may send a heating signal to cease the heating element 150 in the heating compartment 112C or may not send a heating signal to turn on the heating element 150 if the heating element 150 is not already turned on as the temperature of the volume of heated liquid is higher than the temperature of the volume of liquid in heating compartment 112C. Assuming that the required temperature from the heated liquid supply system is about 80°C, no further heating is required and heating compartment 112C may be the last heating compartment 112L and an equivalent volume of heated liquid as the volume of supply liquid may be channelled out of heating compartment 112 C to be supplied to the facilities.

[0066] Assuming that a volume of heated liquid at 80°C is required, if there are subsequent heating compartments 112 after heating compartment 112C, i.e. heating compartment 112C may not be the last heating compartment 112L, the subsequent heating compartments 112 may be heated to a pre-determined temperature of 80°C and the volume of heated liquid from heating compartment 112C may be channelled into the subsequent heating compartments 112. The volume of heated liquid 144 may be channelled out of the last heating compartment 112L (i.e. last of the subsequent heating compartments 112) and supplied to the facilities. If the temperature of the volume of heated liquid 144 flowing “through” the subsequent heating compartments 112 falls below the pre-determined temperature, e.g. 80°C, the central processing system 180 may detect the fall in temperature from the thermal signals from one of the heat sensors and send a heating signal to the heating element 150 of relevant heating compartments 112 and increase the temperature of the volume of heated liquid back to the pre-determined temperature 80°C.

[0067] As shown in Fig. 6, the plurality of heating compartments 110 according to the various embodiments above may be a first plurality of heating compartments 110. Heated liquid supply system may further include a second plurality of heating compartments 210. Second plurality of heating compartments 210 may be fluidly connected to the first plurality of heating compartments 110 such that each of the first plurality of heating compartments 110 and second plurality of heating compartments 210 may be adapted to supply a volume of heated liquid. As shown in Fig. 6, first heating compartment 212A of the second plurality of heating compartments 210 may be fluidly connected to the last heating compartment 112L of the plurality of heating compartments 110 such that the plurality of heating compartments 110 may be adapted to channel the volume of heated supply liquid or a portion thereof into the first heating compartment 212A of the second plurality of heating compartments 210. Heated liquid supply system 100 may include at least two plurality of heating compartments 112, e.g. a third, fourth, fifth or more plurality of heating compartments 112.

[0068] First plurality of heating compartments 110, together with the second plurality of heating compartments 210 may be connected to form a single plurality of heating compartments which is arranged in a series configuration. Collectively, the two plurality of heating compartments 110,210 may be known as a group of heating compartments 610. In other words, a group of heating compartments 610 may mean that the heating compartments 112 in the group are connected to one another in series.

[0069] Although the second plurality of heating compartments 210 may be connected to the first plurality of heating compartments 110, the second plurality of heating compartments 210 may be adapted to receiving a volume of supply liquid 142. As shown in Fig. 6, first heating compartment 212A of the second plurality of heating compartments 210 may be adapted to receive a volume of supply liquid 142. First heating compartment 212A may include an inlet 222A for receiving a separate volume of supply liquid which does not come from the first plurality of heating compartments 110. Each of the first plurality of heating compartments 110 and second plurality of heating compartments 210 may be adapted to supply its own volume of heated liquid. First plurality of heating compartments 110 and second plurality of heating compartments 210, each may include an outlet 124L, 224L respectively. First plurality of heating compartments 110 may be connected to the second plurality of heating compartments 210 via a conduit 228. One end of conduit 228 may be

fluidly connected to the outlet 124L of the first plurality of heating compartments 110 and the other end of conduit 228 may be fluidly connected with the outlet 124L such that the volume of heated water from the last heating compartment 112L of the first plurality of heating compartments 110 may be channelled into the first heating compartment 212A of the second plurality of heating compartment.

[0070] Heated liquid supply system 100 as shown in Fig. 6 may include the return conduit 152 fluidly connected to the first heating compartments, e.g. 112A, 212A, to channel excess heated liquid back into the system 100.

[0071] Referring to the group of heating compartments 612 in Fig. 7, one end of conduit 228 may be fluidly connected to the outlet 124L of the first plurality of heating compartments 110 and the other end of conduit 228 may form a T-joint with the outlet 124L such that the volume of heated water from the last heating compartment 112L of the first plurality of heating compartments 110 of a portion thereof may be channelled into the first heating compartment 212A of the second plurality of heating compartment.

[0072] As shown in Fig. 8, heated liquid supply system 102 may include a group of heating compartments 610 and a plurality of heating compartments 110. Group of heating compartments 610 and the plurality of heating compartments 110 may be in a parallel configuration wherein a first volume of supply liquid and a second volume of supply liquid may be channelled into the group of heating compartments 610 and the plurality of heating compartments 110 concurrently. Upon heating up the volumes of supply liquid, a first volume of heated liquid and a second volume of supply liquid may be channelled from the group of heating compartments 610 and the plurality of heating compartments 110 respectively.

[0073] Referring to Fig. 7 or 8, method 1000 may further include a step of heating a volume of liquid within each heating compartment 212 of the second plurality of heating compartments 210 and/or a step of channelling the volume of heated supply liquid 244 from the first plurality of heating compartments 110 into the first compartment 212A of the second plurality of heating compartments 210.

[0074] By having a plurality of heating compartments arranged in a series, there may be redundancy built into the heated liquid supply system 102. For example, in the event that

one of the heating compartments 112 is down, e.g. failure of heating element, the heating compartment may be used as a by-pass and the remaining heating compartments 112 may be used to heat the liquid flowing through the system. In this way, the heated liquid supply system 100 can still be operable even though a portion of the heating compartments malfunction.

[0075] Fig. 9 shows an exemplary embodiment of the heated liquid supply system 103 having at least four plurality of heating compartments 110,220,330,440. The volume of liquid in each heating compartment 112 may have been heated to a pre-determined temperature of the heating compartment 112. As shown in Fig. 9, heated liquid supply system 103 may include at least two groups of heating compartments 610, e.g. three, four, five or more groups. The groups of heating compartments may be arranged in a parallel configuration.

[0076] Assuming that the flow rate of the heated liquid supply system 103 based on a system of four plurality of heating compartments is 100%, the flow rate for any one of the plurality of heating compartments may be 25%, any two of the plurality of heating compartments may be 50% etc.

[0077] Referring to Fig. 9, a portion of the plurality of heating compartments 110,410 may be turned on to heat the volume of supply liquid entering each heating compartments 112. When on a portion of the plurality of heating compartments 110,410 is turned on, a portion of the flow rate of the heated liquid supply system 103 is utilised. For example, 50% of the number of plurality of heating compartments 110,410, may be turned on. As such, only 50% of the capacity of the heated liquid supply system 103 is utilised. The first two heating compartments 112A,112B,312A,312B of each group of heating compartments 610 may be turned on. Depending on the requirement, e.g. flow rate, more than two heating compartments of each plurality of heating compartments or group of heating compartments may be turned on. For each heating compartment 112 that is not turned on, energy used to heating each heating compartment 112 may be saved. As such, there may be approximately 50% savings in the energy usage to heat up the liquid for the heated liquid supply system 103 if only 50% of the capacity of the heated liquid supply system 100, e.g. plurality of heating compartment 110 and 410, is turned on. To turn on a plurality of heating compartments 110 may mean to turn on the valve to the first heating compartment of each

plurality of heating compartments to channel liquid into the plurality of heating compartments 110.

[0078] Referring to Fig. 10, an exemplary embodiment of the heated liquid supply system 104 having a plurality of heating compartments 110 and a group of heating compartments 610, having three plurality of heating compartments 210,310,410, is shown. In Fig. 10, only the first two heating compartments 112A,112B,212A,212B of each plurality of heating compartments, e.g. 110, and group, e.g. 610, may be turned on. Accordingly, only two plurality of heating compartments 110,310 of the four plurality of heating compartments may be used. As such, about 50% of the heating capacity of the heated liquid supply system 100 is used. Accordingly, there may be an energy saving of about 50%.

[0079] Referring to Fig. 11, an exemplary embodiment of the heated liquid supply system 105 having a plurality of heating compartments 110 and a group of heating compartments 610, having three plurality of heating compartments 210,310,410, is shown. In Fig. 11, only heating compartments 112A,112B,212A,212B may be turned on. Accordingly, only two plurality of heating compartments 110,210 of the four plurality of heating compartments are used. As such, about 50% of the heating capacity of the heated liquid supply system 105 is used. Accordingly, there may be an energy saving of about 50%.

[0080] Referring to Fig. 12, an exemplary embodiment of the heated liquid supply system 106 having two plurality of heating compartments 110,210 and a group of heating compartments 610, having two plurality of heating compartments 310,410, is shown. In Fig. 12, only heating compartments 112A,112B,212A,212B,312A,312B may be turned on. Accordingly, only three plurality of heating compartments 110,210,310 of the four plurality of heating compartments are used. As such, about 75% of the heating capacity of the heated liquid supply system 100 is used. Accordingly, there may be an energy saving of about 25%.

[0081] Referring to Fig. 13, an exemplary embodiment of the heated liquid supply system 107 having a group of heating compartments 610 with four plurality of heating compartments 110,210,310,410, is shown. In Fig. 13, if only heating compartments 112A,112B are turned on, only one plurality of heating compartments 110 is used. As such, about 25% of the heating capacity of the heated liquid supply system 107 is used with an energy saving of about 75%. Clearly, if more heating compartments in more plurality of heating compartments are turned on, the heating capacity used may be increase and

consequently the energy saving may reduce. In Fig. 13, heated liquid from each plurality of heating compartments may be supplied and/or channelled to the next plurality of heating compartments.

[0082] Fig. 14 may be similar to Fig. 15 except that the heated liquid from a plurality of heating compartments, e.g. 110, may be channelled only to the next plurality of heating compartments, e.g. 210.

[0083] Referring to Fig. 15, an exemplary embodiment of the heated liquid supply system 108 having four plurality of heating compartments 110,210,310,410 is shown. In Fig. 14, each plurality of heating compartments may be turned on individually.

[0084] As shown in Fig. 16, the heated liquid supply system 100,101,102,103,104,105,106,107,108 may be used in a building heating/cooling system 900. Heated liquid supply system 100 may receive water supply from a domestic water storage 910. Heated liquid supply system 100 may supply heated water to cater to the needs of a building's heating and cooling system, e.g. a absorption chiller 920 and domestic hot water supply circuit, so as to support the function of facilities like the cooling tower 930, air handling unit 940, and cooling water supply circuit. Ultimately, the heated liquid supply system 100 enables the functioning of the air-conditioning and water heater system to cater to the needs of the residence in the building. The functioning of the heating and cooling system may be controlled by a control unit, e.g. a CPU.

Claims

1. A heated liquid supply system comprising:

a plurality of heating compartments, each heating compartment of the plurality of heating compartments being fluidly connected to another heating compartment of the plurality of heating compartments, each heating compartment is adapted to contain a volume of liquid therein and heat the volume of liquid to a pre-determined temperature for said each heating compartment, each heating compartment of the plurality of heating compartments is adapted to receive a volume of supply liquid at a pre-determined flow rate, and discharge a volume of heated liquid into an adjacent fluidly connected heating compartment;

wherein each heating compartment of the plurality of compartments is adapted to heat each volume of supply liquid entering said each heating compartment when the temperature of each volume of supply liquid is below the pre-determined temperature of said each heating compartment;

wherein a first heating compartment of the plurality of heating compartments is adapted to receive a volume of supply liquid to be heated up and a last heating compartment of the plurality of heating compartments is adapted to discharge the volume of heated supply liquid to be supplied.

2. The heated liquid supply system of claim 1, wherein the plurality of heating compartments are sequentially connected to each other.
3. The heated liquid supply system of claim 1 or 2, wherein the pre-determined temperature of a heating compartment of the plurality of heating compartments is the same as or different from the pre-determined temperature of another heating compartment.
4. The heated liquid supply system of claim 1 or 2, wherein the pre-determined temperature of a heating compartment of the plurality of heating compartments is higher than the pre-determined temperature of another heating compartment downstream the heating compartment.
5. The heated liquid supply system of any one of claims 1 to 4, wherein the plurality of heating compartments are thermally insulated from each other.

6. The heated liquid supply system of any one of claims 1 to 5, wherein each heating compartment of the plurality of compartments comprises an inlet, an outlet spaced from the inlet, a heating element at about the inlet, said heating element adapted to heat the volume of liquid that has entered each heating compartment via the inlet when the temperature of the volume of liquid is lower than the pre-determined temperature of the heating compartment.
7. The heated liquid supply system of any one of claims 1 to 6, wherein the heating element is disposed between the inlet and the outlet.
8. The heated liquid supply system of any one of claims 1 to 7, wherein each heating compartment of the first plurality of heating compartment is a heating tank.
9. The heated liquid supply system of any one of claims 1 to 8, further comprising a further plurality of heating compartments according to the plurality of heating compartments in any one of claims 1 to 8, wherein the further plurality of heating compartments are fluidly connected to the plurality of heating compartments.
10. The heated liquid supply system of claim 9, wherein a first heating compartment of the further plurality of heating compartments is fluidly connected to the last heating compartment of the plurality of heating compartments such that the plurality of heating compartments is adapted to channel the volume of heated supply liquid or a portion thereof into the first heating compartment of the further plurality of heating compartments.
11. The heated liquid supply system of claim 10, wherein the first heating compartment of the further plurality of heating compartments is adapted to receive a volume of supply liquid.
12. The heated liquid supply system of any one of claims 1 to 11, further comprising a control system configured to control the heating process of the heated liquid supply system, the control system comprising a central processing unit, wherein the central processing unit is in communication with each heating compartment of the plurality of heating compartments.
13. The heated liquid supply system of claim 12, wherein the control system comprises a heat sensing module in communication with the central processing unit, the heat sensing module being in communication with the heat sensor of each heating compartment

14. The heated liquid supply system of claim 12 or 13, wherein the control system comprises a heating module in communication with the central processing unit, the heating module being in communication with the heating element of each heating compartment.

15. A method of heating liquid with a heated liquid supply system of claim 1, the method comprising:

heating the volume of liquid within each heating compartment of the plurality of heating compartments to a pre-determined temperature determined for each heating compartment of the plurality of heating compartments;

receiving a volume of supply liquid into the first heating compartment of the plurality of heating compartments and heating the volume of supply liquid;

discharging the volume of heated liquid from the first heating compartment of the plurality of heating compartments into the adjacent fluidly connected heating compartment of the plurality of heating compartments;

heating each volume of supply liquid that entered each heating compartment of the plurality of heating compartments to the pre-determined temperature of the each heating compartment when the temperature of each volume of supply liquid is below the pre-determined temperature of said each heating compartment; and

discharging the volume of heated supply liquid from the last heating compartment of the first plurality of heating compartments.

16. The method of claim 15, further comprising,

heating a volume of liquid within each heating compartment of the further plurality of heating compartments in claim 9; and

channelling the volume of heated supply liquid from the plurality of heating compartments into the first compartment of the further plurality of heating compartments.

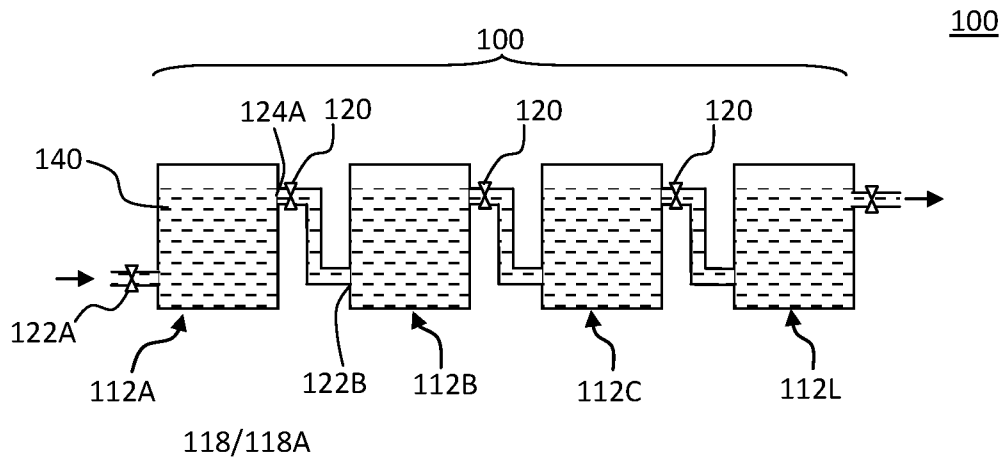

Fig. 1

112

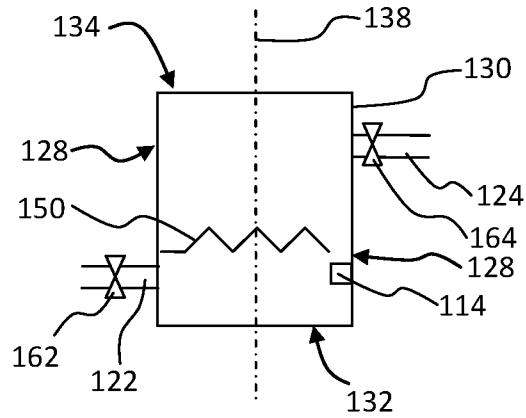

Fig. 2

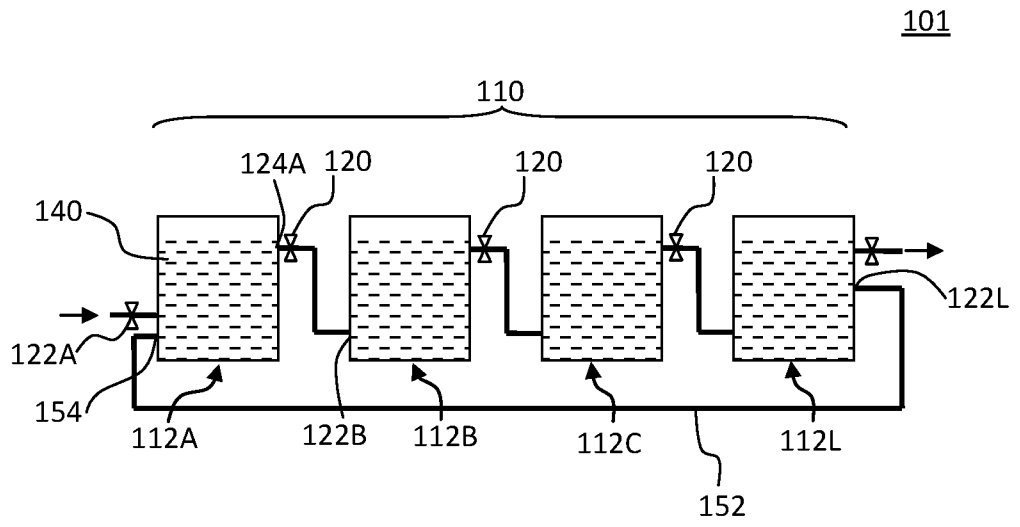

Fig. 3

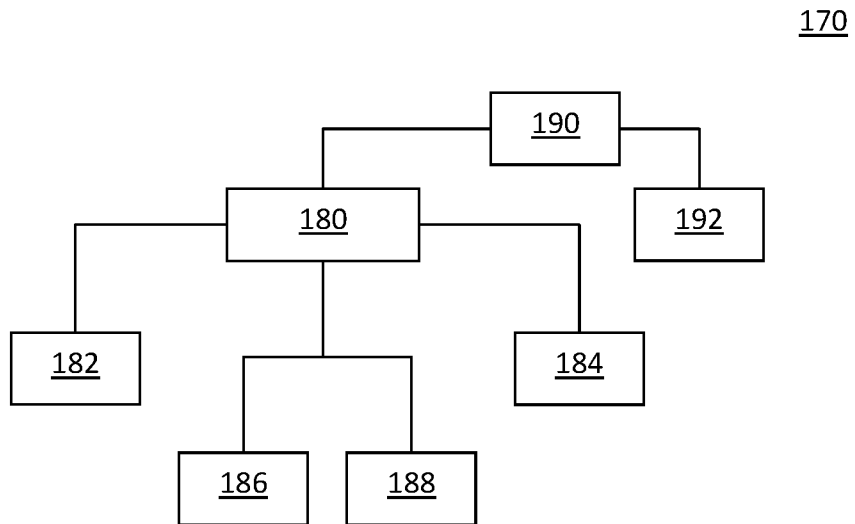

Fig. 4

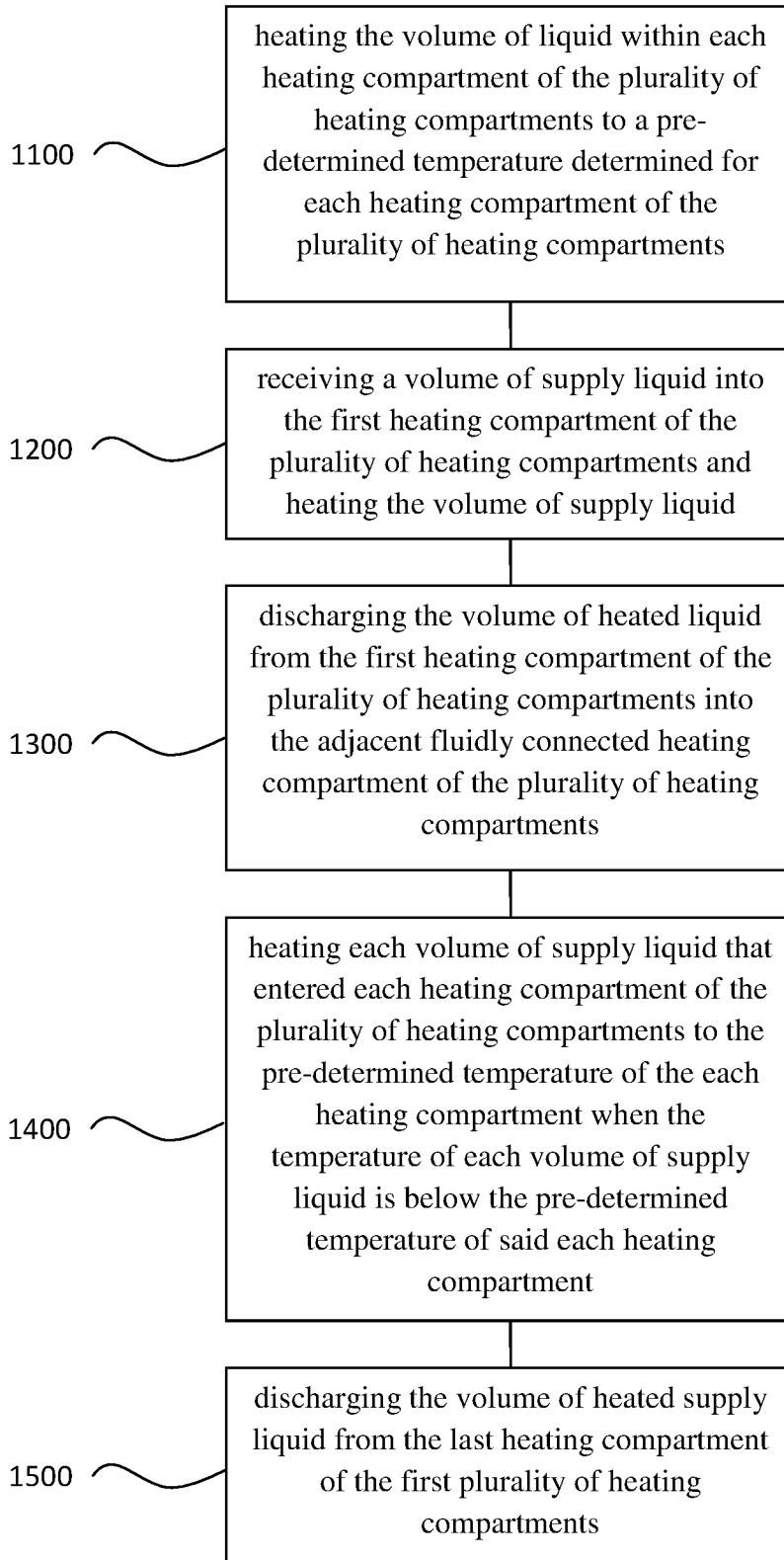

Fig. 5

610

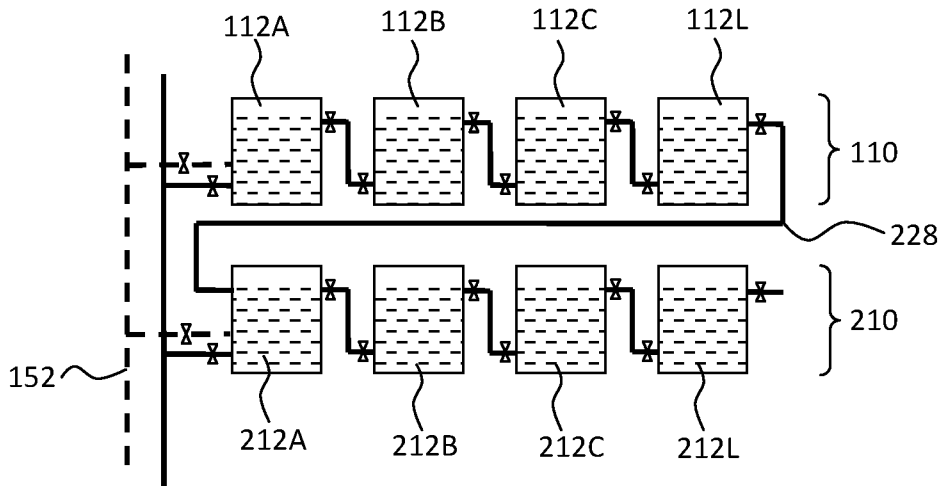

Fig. 6

612

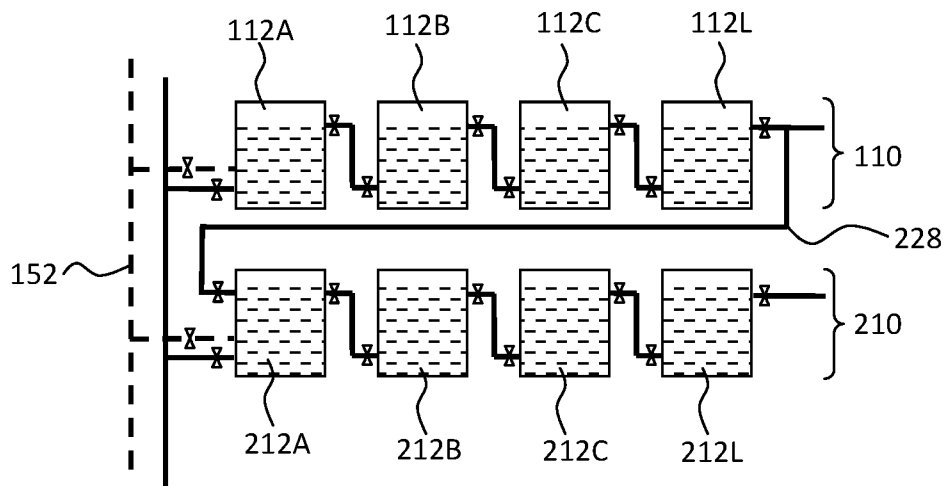

Fig. 7

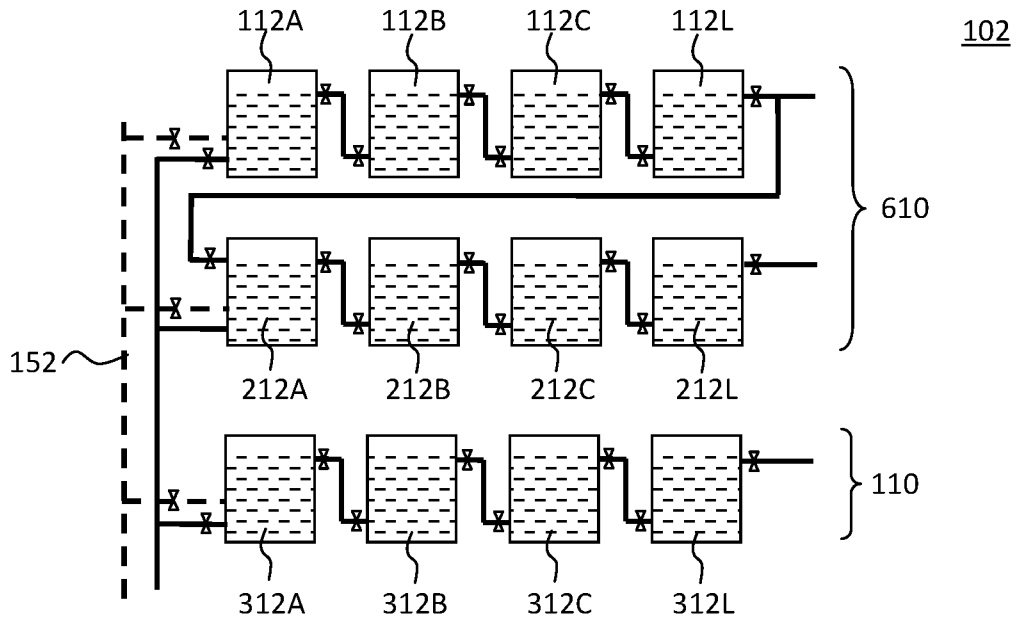

Fig. 8

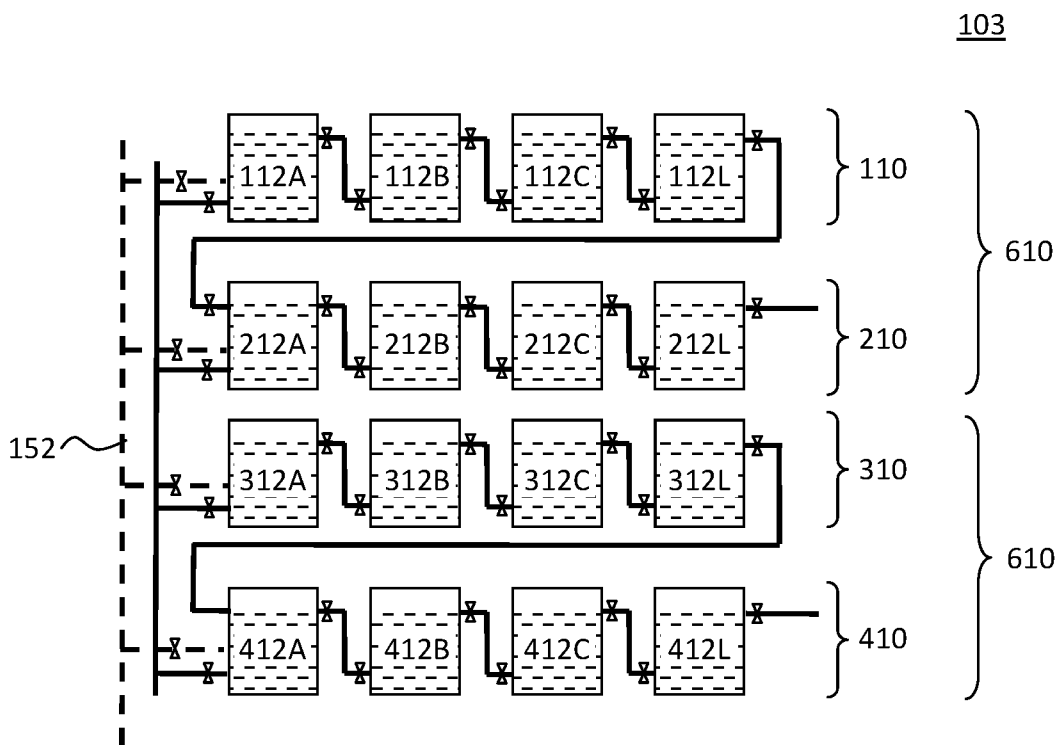

Fig. 9

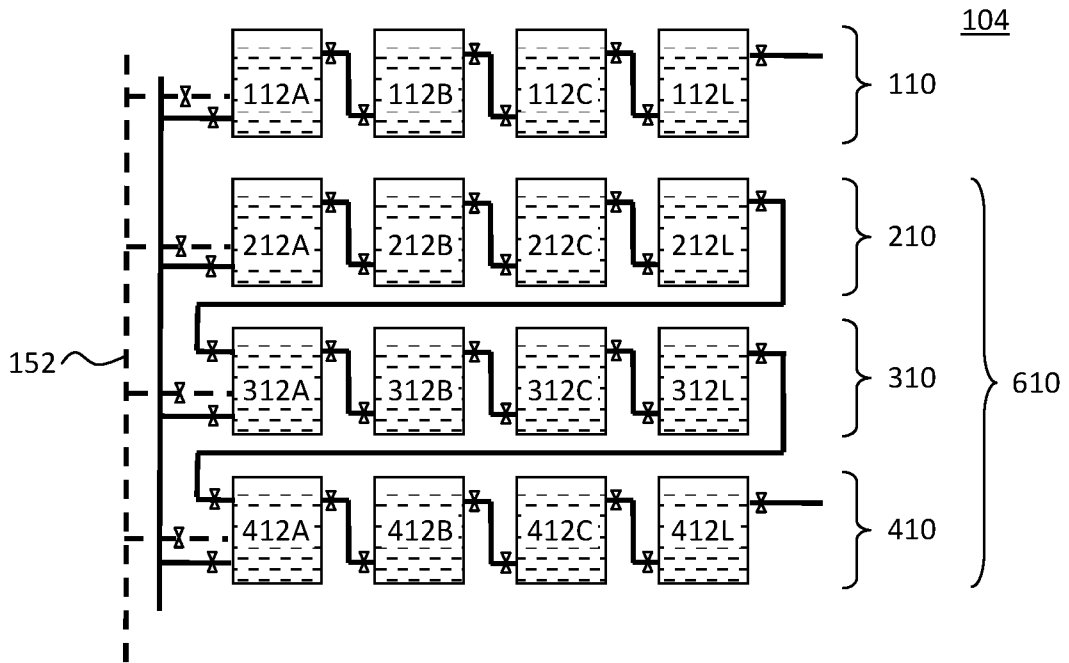

Fig. 10

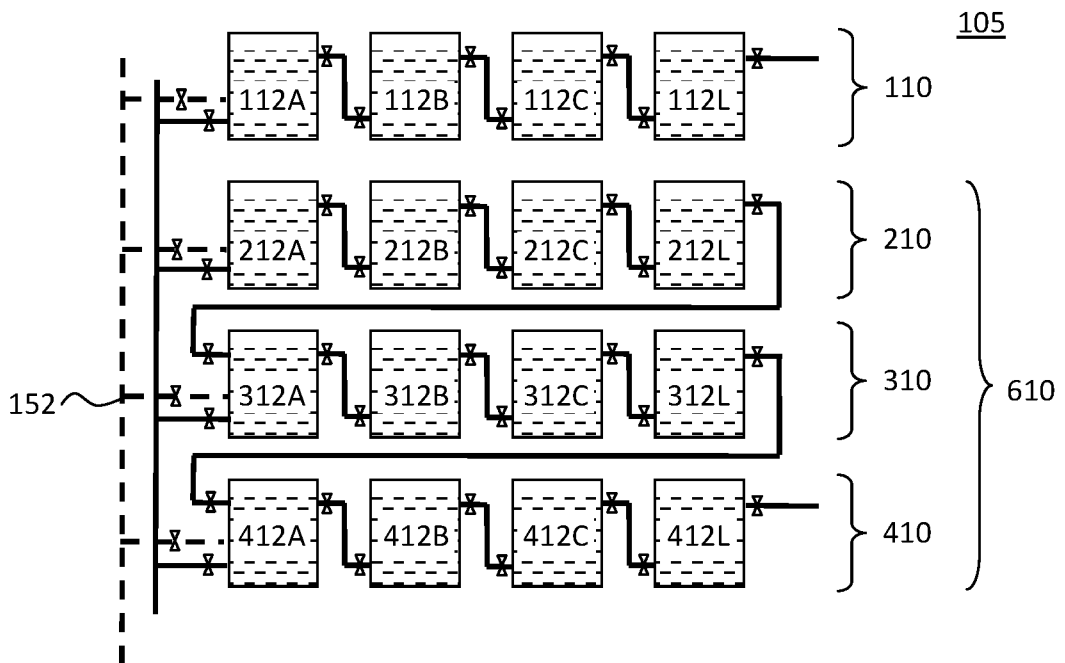

Fig. 11

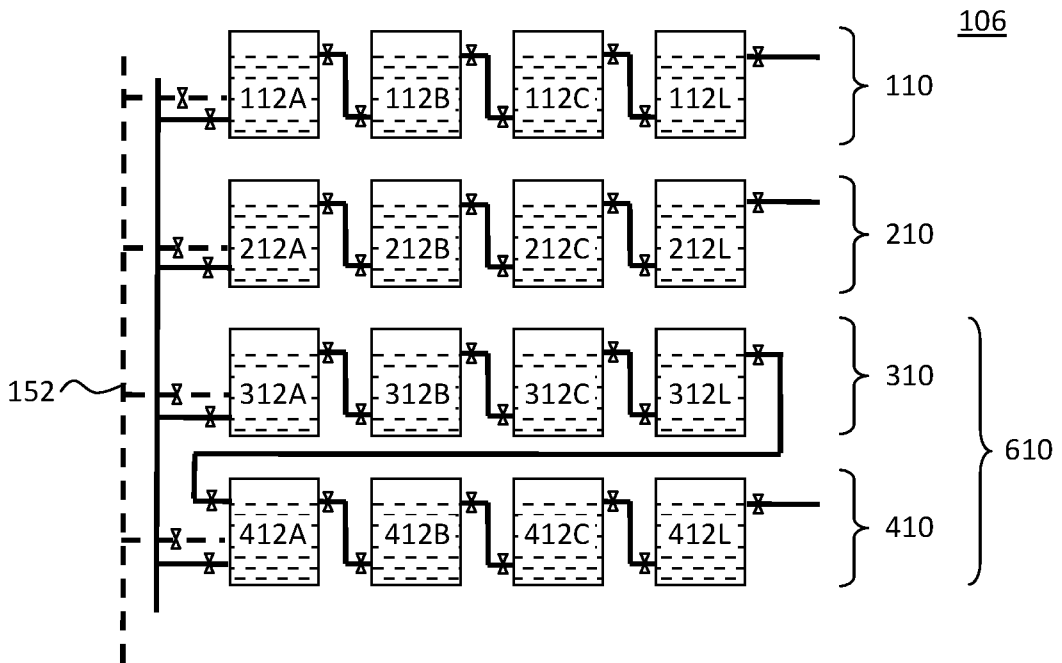

Fig. 12

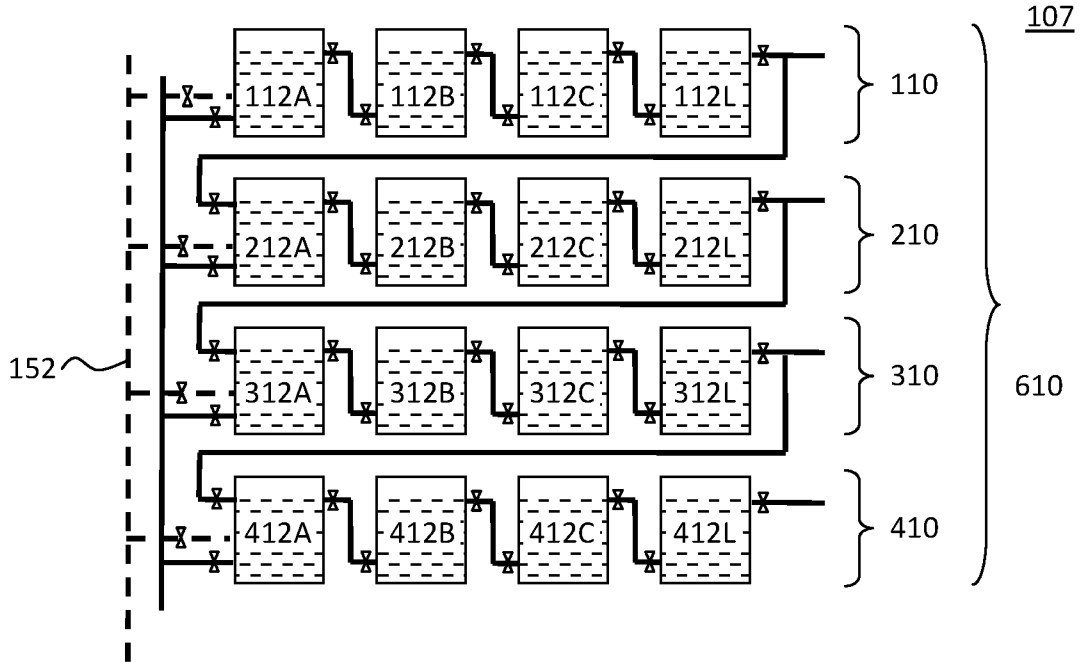

Fig. 13

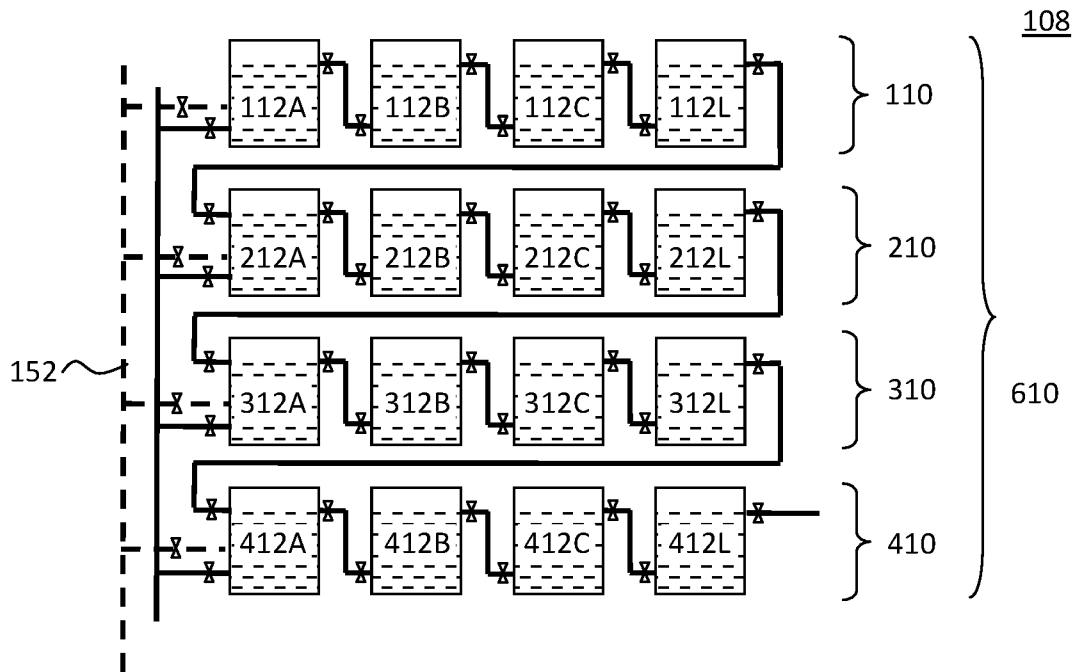

Fig. 14

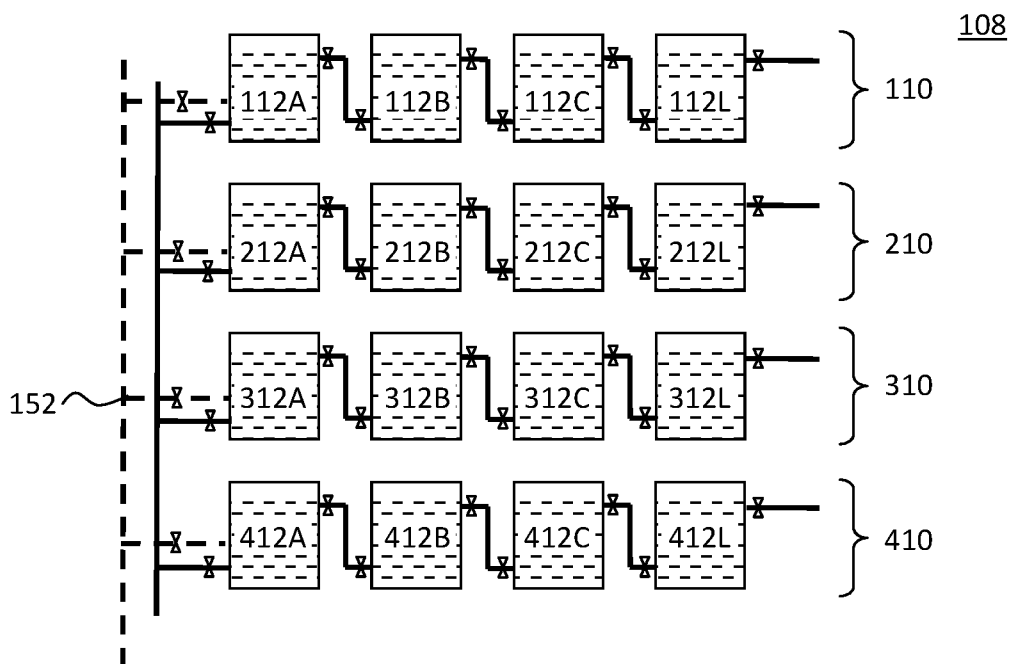

Fig. 15

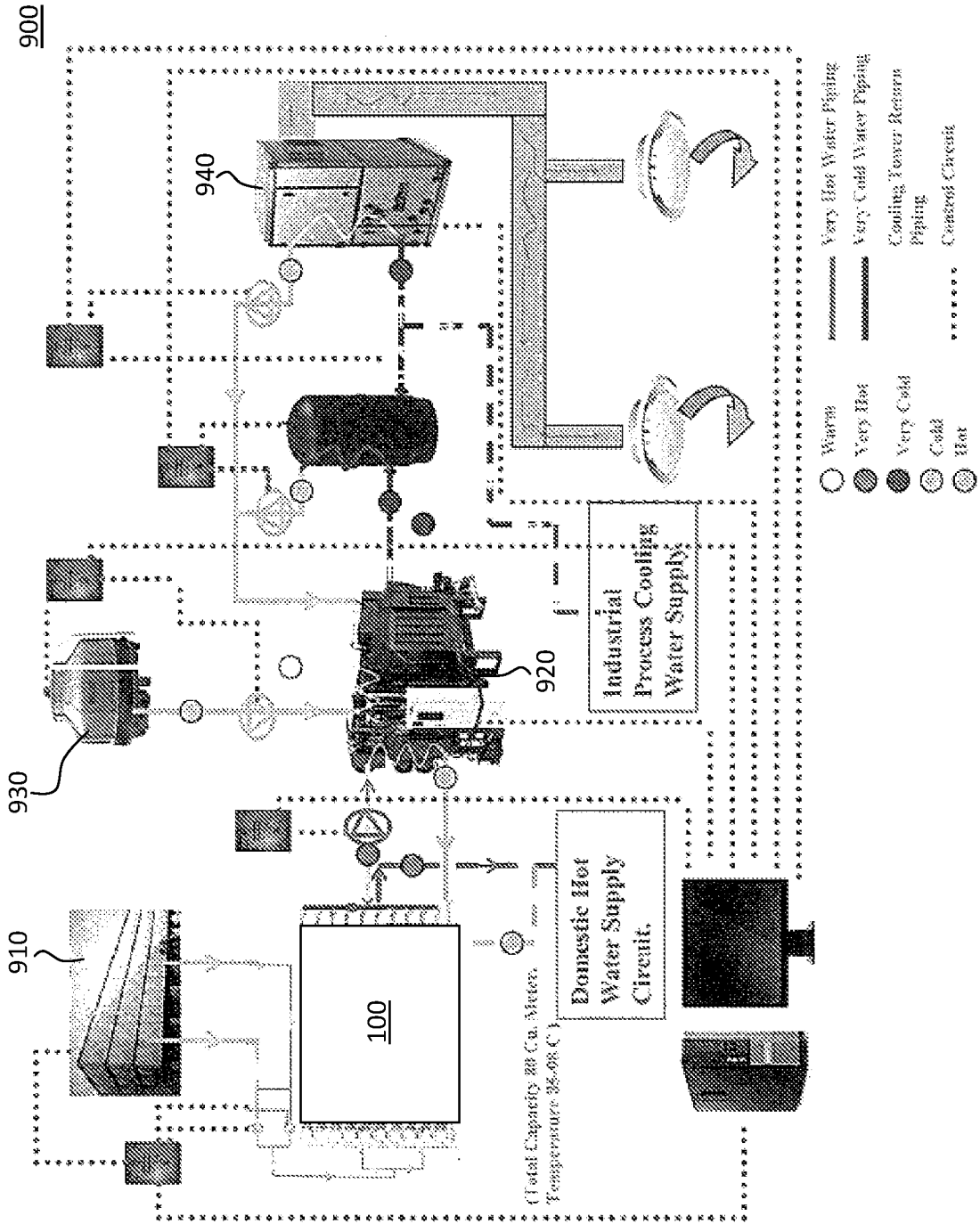

Fig. 16

A. CLASSIFICATION OF SUBJECT MATTER

F24H 1/18 (2006.01) F24H 1/10 (2006.01) F24D 17/00 (2006.01)

According to International Patent Classification (IPC) or to both national classification and IPC

B. FIELDS SEARCHED

Minimum documentation searched (classification system followed by classification symbols)

Documentation searched other than minimum documentation to the extent that such documents are included in the fields searched

Electronic data base consulted during the international search (name of data base and, where practicable, search terms used)

Databases: EPODOC, WPIAP, TXPEA, TXPEB, TXPEC, TXPEE, TXPEF, TXPEH, TXPEI, TXPEP, TXTPEPEA, TXPES, TXPUSE0A, TXPUSE1A, TXPUSEA, TXPUSEB, TXPWOEA; IPC/CC: F24D19/-, F24D12/02, F24D17/-, Y02B30/14, F24H1/-, F24H4/-, F24H7/-, F24H9/- & keywords (water, liquid, fluid, heating, tank, vessel, reservoir, chamber, compartment, container, holder, series, consecutive, sequential, continuous, plurality, additional, multiple, dual, twin, secondary, auxiliary, subsidiary, many and similar terms);

Espacenet, Google Scholar & Google Patents: keywords (water, liquid, fluid, heating, tank, vessel, reservoir, chamber, compartment, container, holder, series, consecutive, sequential, continuous, plurality, additional, multiple, dual, twin, secondary, auxiliary, subsidiary, many, control, regulate, sensor, sensing means)

Applicant name search is done on "Freshtech Technology" and inventor name search is done on "Lim Kim San" through Espacenet and AusPat.

C. DOCUMENTS CONSIDERED TO BE RELEVANT

Category*	Citation of document, with indication, where appropriate, of the relevant passages	Relevant to claim No.
	Documents are listed in the continuation of Box C	



Further documents are listed in the continuation of Box C



See patent family annex

* Special categories of cited documents:		
"A" document defining the general state of the art which is not considered to be of particular relevance	"T" later document published after the international filing date or priority date and not in conflict with the application but cited to understand the principle or theory underlying the invention	
"E" earlier application or patent but published on or after the international filing date	"X" document of particular relevance; the claimed invention cannot be considered novel or cannot be considered to involve an inventive step when the document is taken alone	
"L" document which may throw doubts on priority claim(s) or which is cited to establish the publication date of another citation or other special reason (as specified)	"Y" document of particular relevance; the claimed invention cannot be considered to involve an inventive step when the document is combined with one or more other such documents, such combination being obvious to a person skilled in the art	
"O" document referring to an oral disclosure, use, exhibition or other means	"&" document member of the same patent family	
"P" document published prior to the international filing date but later than the priority date claimed		

Date of the actual completion of the international search
22 July 2015Date of mailing of the international search report
22 July 2015

Name and mailing address of the ISA/AU

AUSTRALIAN PATENT OFFICE
PO BOX 200, WODEN ACT 2606, AUSTRALIA
Email address: pct@ipaaustralia.gov.au

Authorised officer

Hatinder Sharma
AUSTRALIAN PATENT OFFICE
(ISO 9001 Quality Certified Service)
Telephone No. 0262256151

INTERNATIONAL SEARCH REPORT

International application No.

C (Continuation).

DOCUMENTS CONSIDERED TO BE RELEVANT

PCT/SG2015/050179

Category*	Citation of document, with indication, where appropriate, of the relevant passages	Relevant to claim No.
X	US 5317670 A (ELIA) 31 May 1994 abstract; col 2, line 49 to col 3, line 31; col 4, line 14 to col 8, line 31; fig. 1	1-16
X	US 2005/0025471 A1 (HO) 03 February 2005 abstract; para 0007-0015; para 0031-0052; figs. 1-11	1-3, 6-8, 15-16
X	JP S59-145439 A (TAKAHASHI YUUZOU et al.) 20 August 1984 & English abstract retrieved from EPODOC abstract; fig. 3	1-3, 6-8, 15-16

INTERNATIONAL SEARCH REPORT

Information on patent family members

International application No.

PCT/SG2015/050179

This Annex lists known patent family members relating to the patent documents cited in the above-mentioned international search report. The Australian Patent Office is in no way liable for these particulars which are merely given for the purpose of information.

Patent Document/s Cited in Search Report		Patent Family Member/s	
Publication Number	Publication Date	Publication Number	Publication Date
US 5317670 A	31 May 1994	US 5317670 A	31 May 1994
		AU 2794992 A	21 May 1993
		CA 2080946 A1	20 Apr 1993
		WO 9308431 A1	29 Apr 1993
US 2005/0025471 A1	03 February 2005	US 2005025471 A1	03 Feb 2005
		US 6957014 B2	18 Oct 2005
		AU 2002351881 A1	15 Jul 2003
		WO 03056248 A1	10 Jul 2003
JP S59-145439 A	20 August 1984	JP S59145439 A	20 Aug 1984

End of Annex