



US 20050127735A1

(19) **United States**

(12) **Patent Application Publication**
Munsch

(10) **Pub. No.: US 2005/0127735 A1**

(43) **Pub. Date: Jun. 16, 2005**

(54) **VEHICLE SEAT WITH ADJUSTABLE SUPPORT SYSTEM**

Publication Classification

(76) **Inventor: Kenneth Munsch, Holland, MI (US)**

(51) **Int. Cl.⁷ A47C 7/36**

(52) **U.S. Cl. 297/391**

Correspondence Address:
BRINKS HOFER GILSON & LIONE
P.O. BOX 10395
CHICAGO, IL 60610 (US)

(57) **ABSTRACT**

(21) **Appl. No.: 10/980,887**

(22) **Filed: Nov. 3, 2004**

Related U.S. Application Data

(60) **Provisional application No. 60/517,311, filed on Nov. 3, 2003.**

A seating structure is provided for use with an elastomeric membrane with an edge portion. A carrier member is also provided having a central opening. The edge portion of the elastomeric membrane is connected to the carrier member and covering the central opening. A metal support frame is connected the carrier member. The seating structure may also include an elastomeric headrest and one or more covers for the seat and backrest.

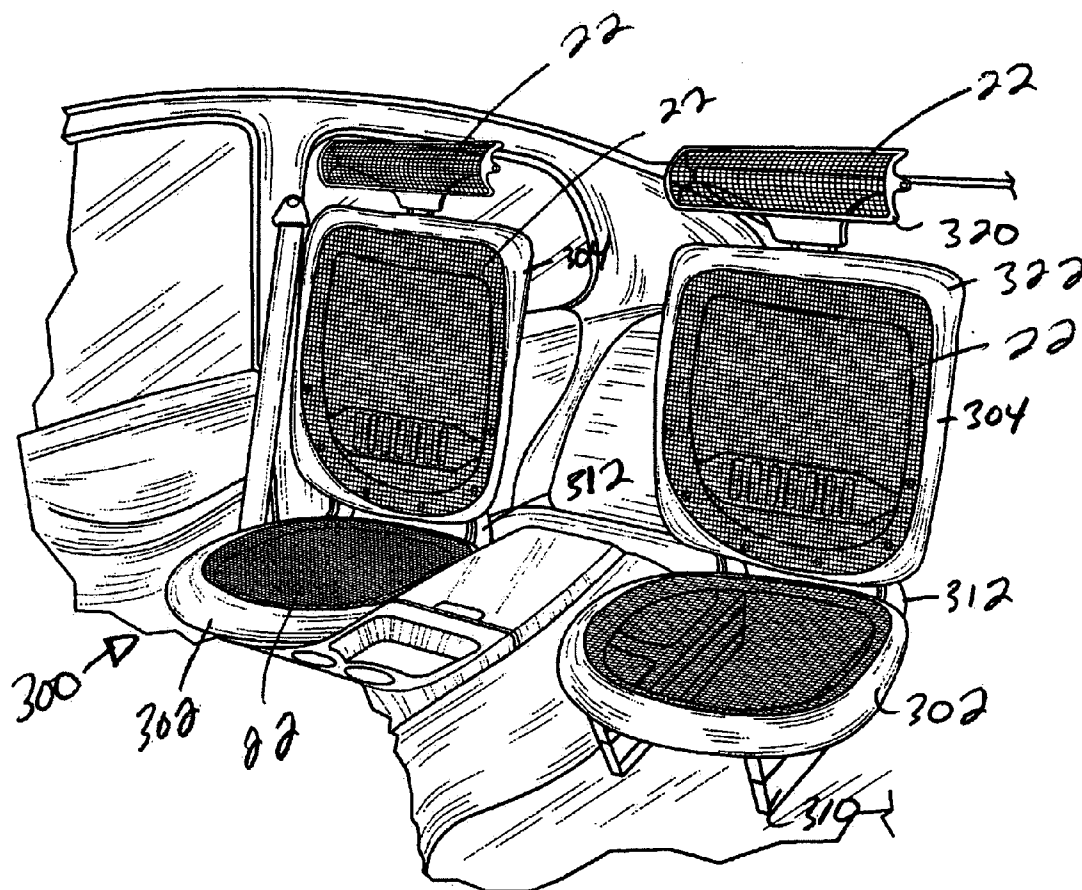

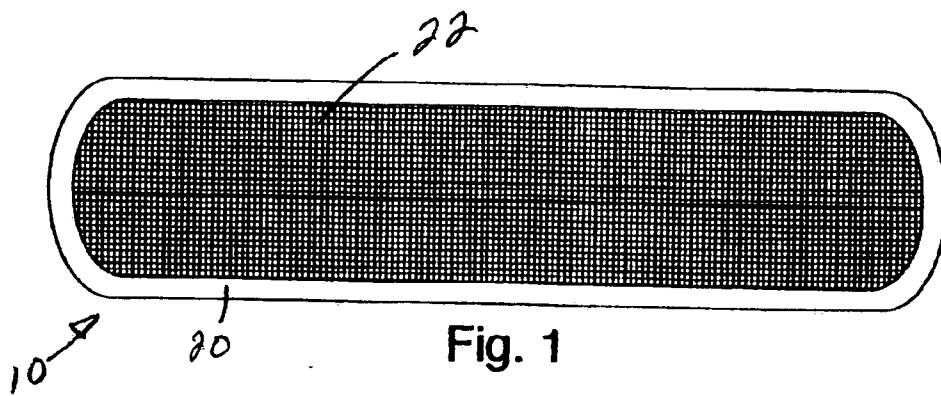

Fig. 1

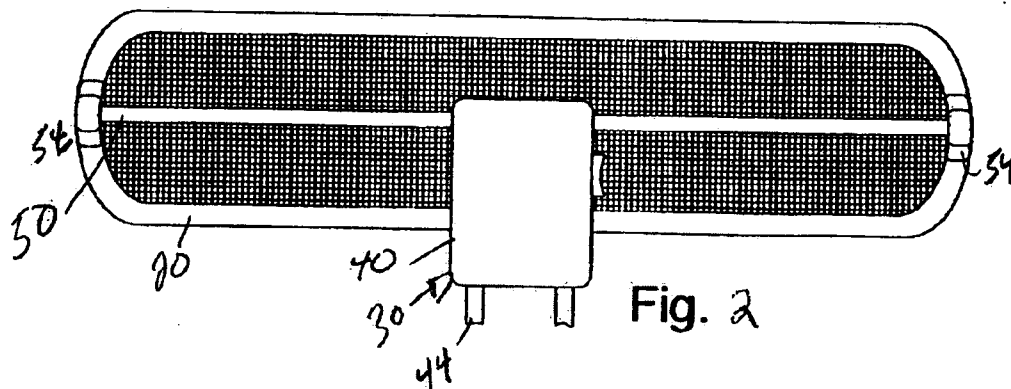

Fig. 2

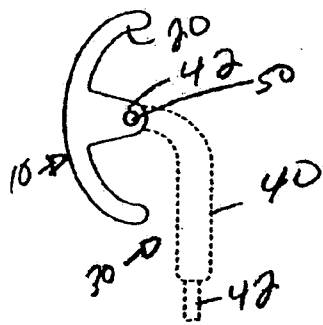

Fig. 3

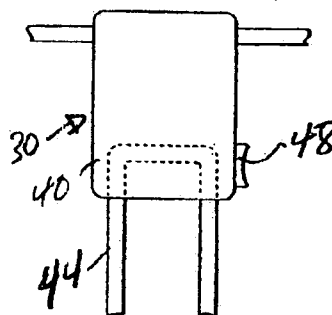
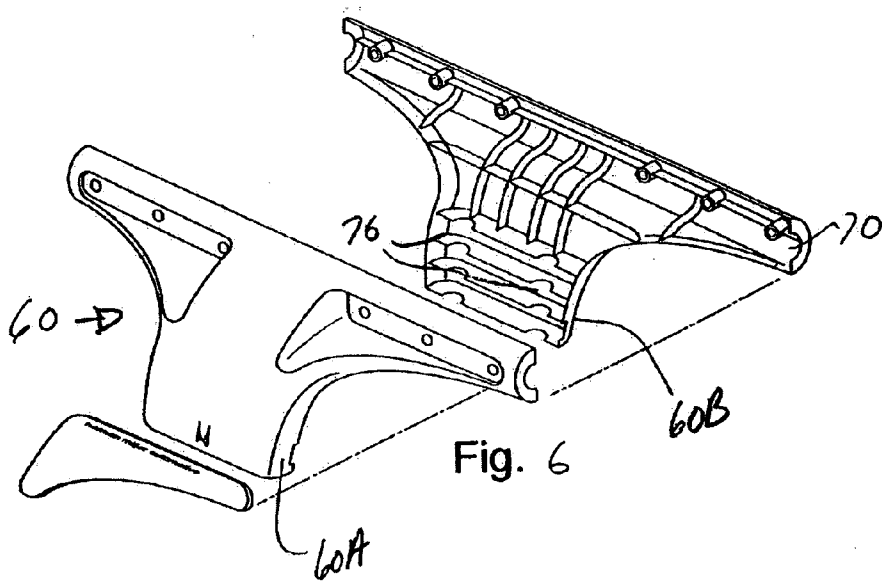
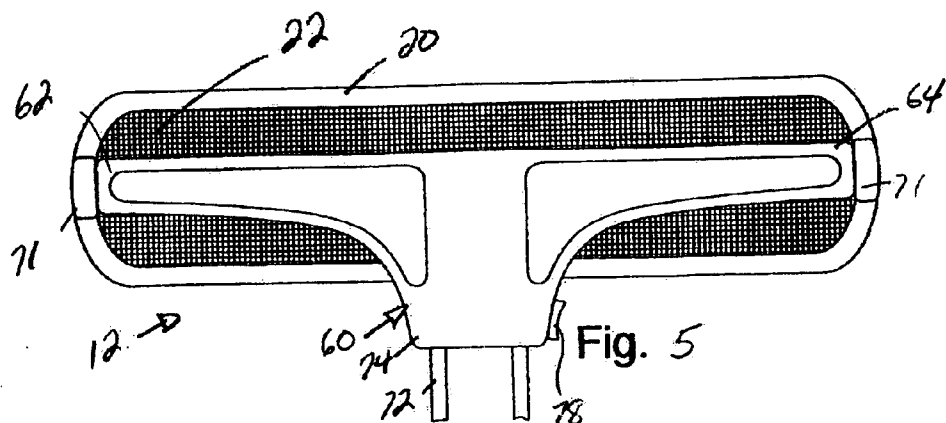

Fig. 4



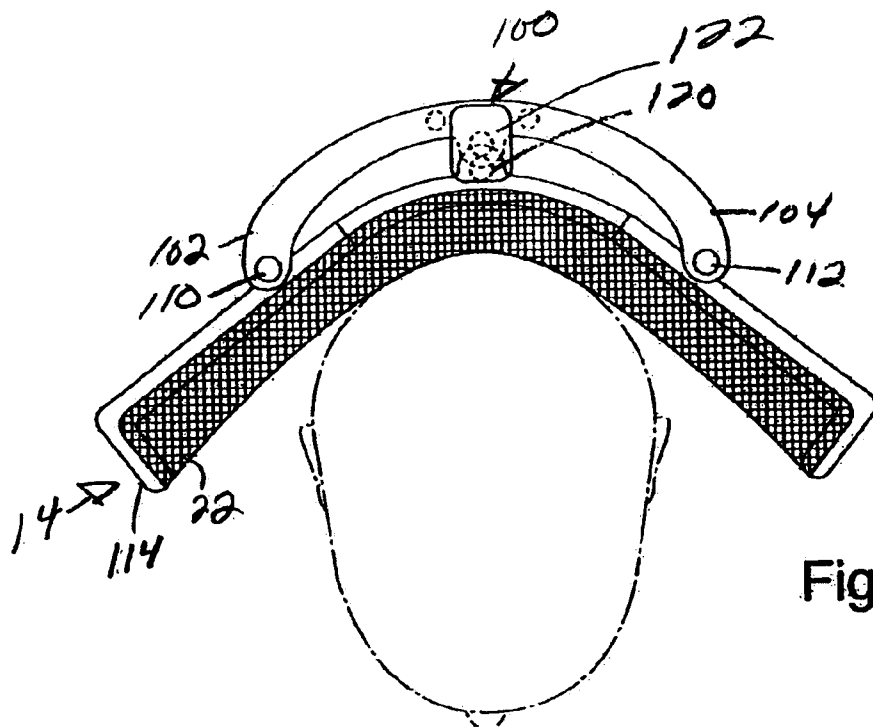
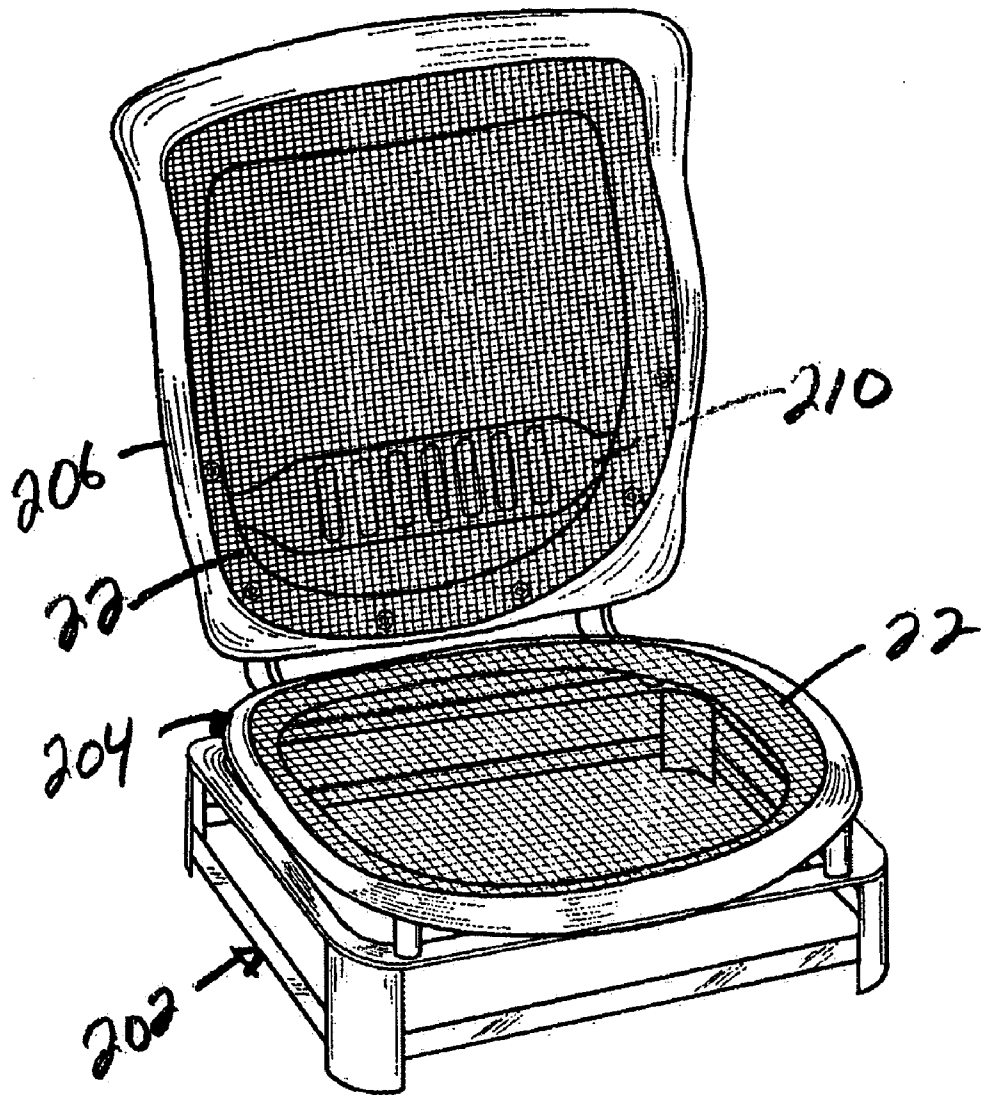

Fig. 7



200 →
Fig. 8

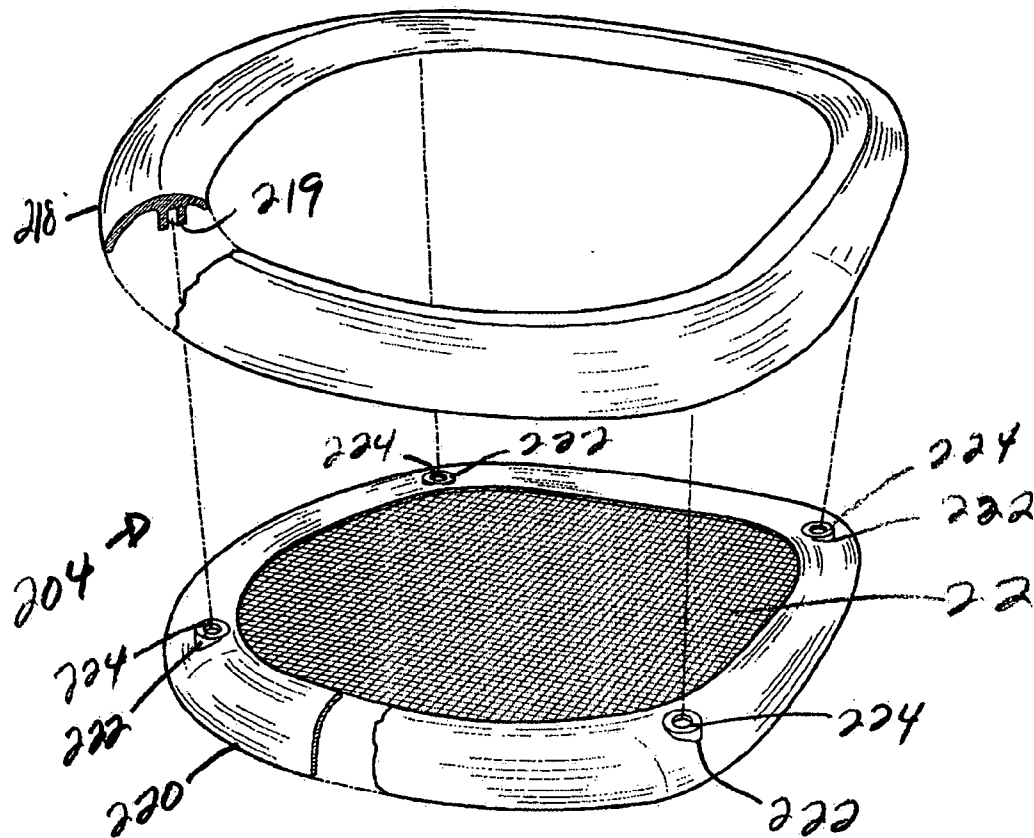
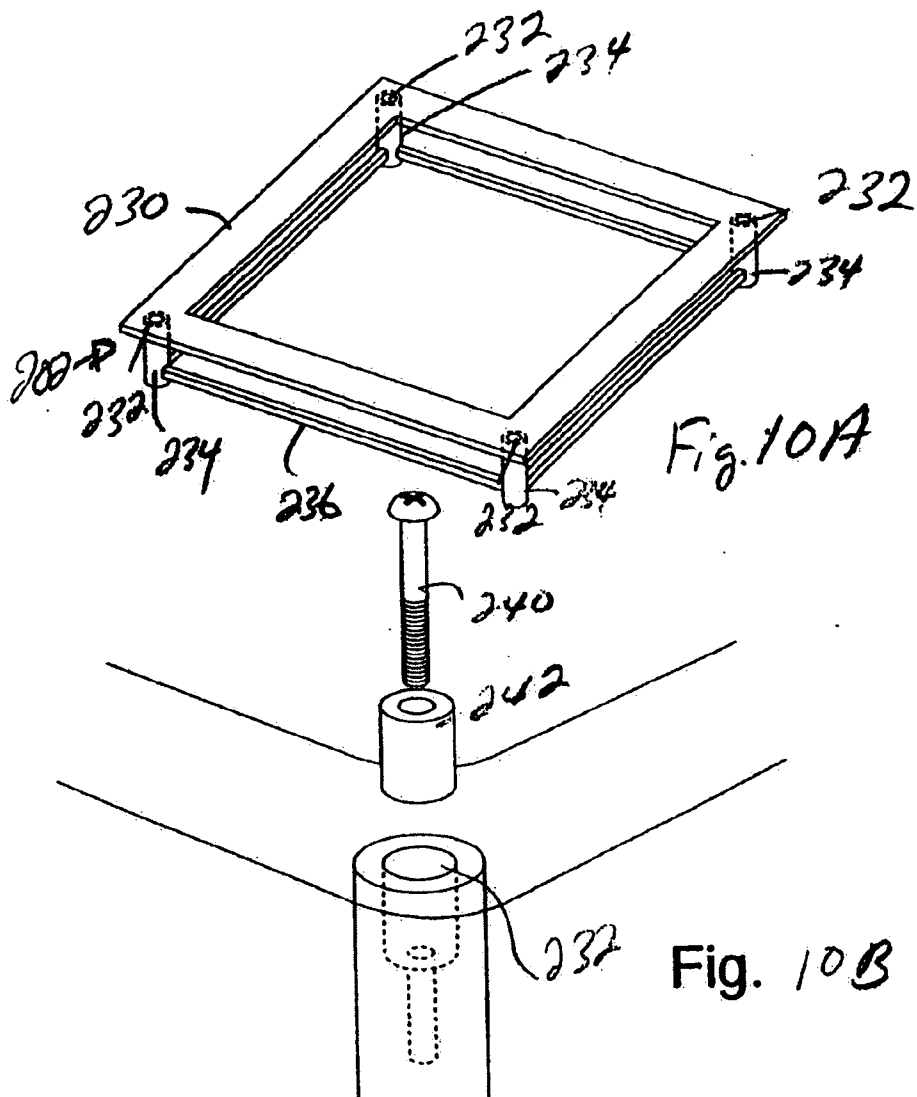

Fig. 9



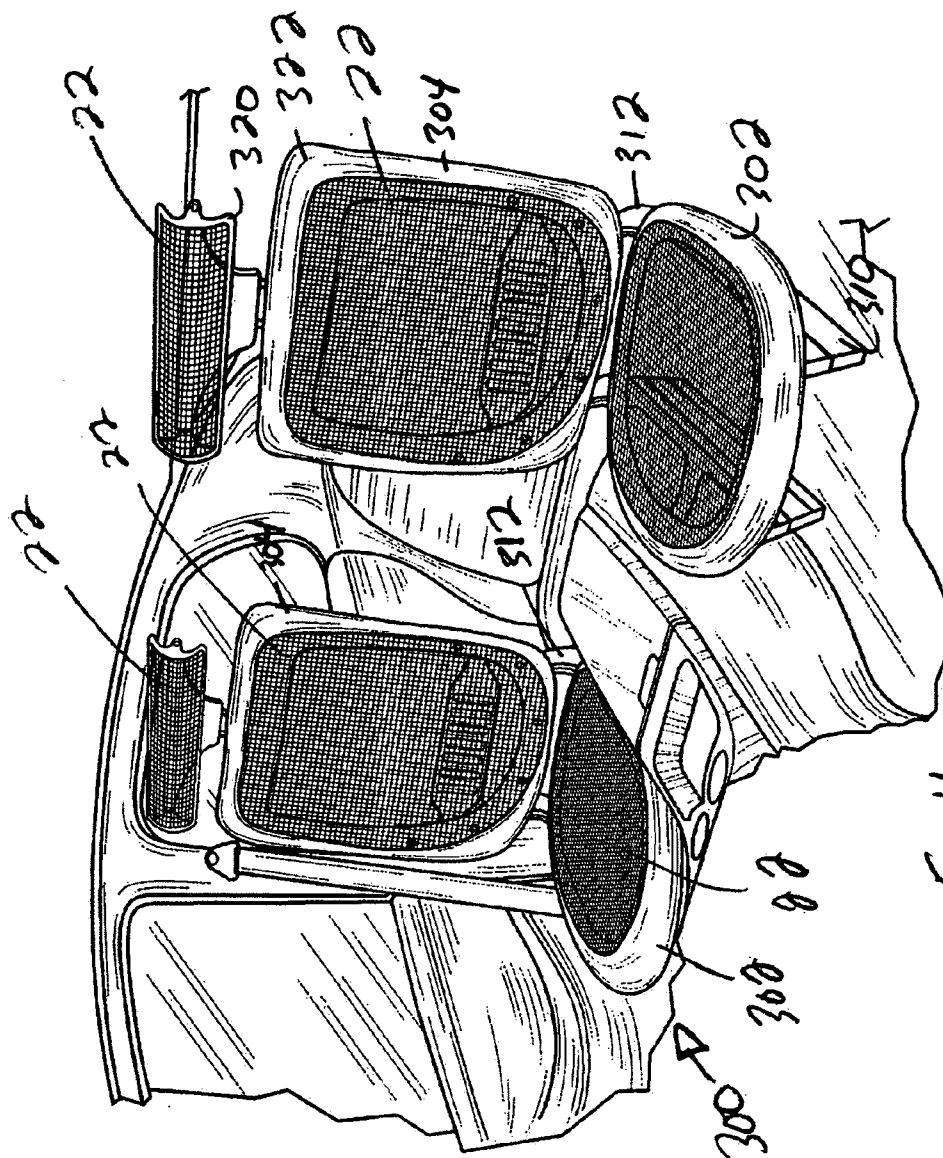
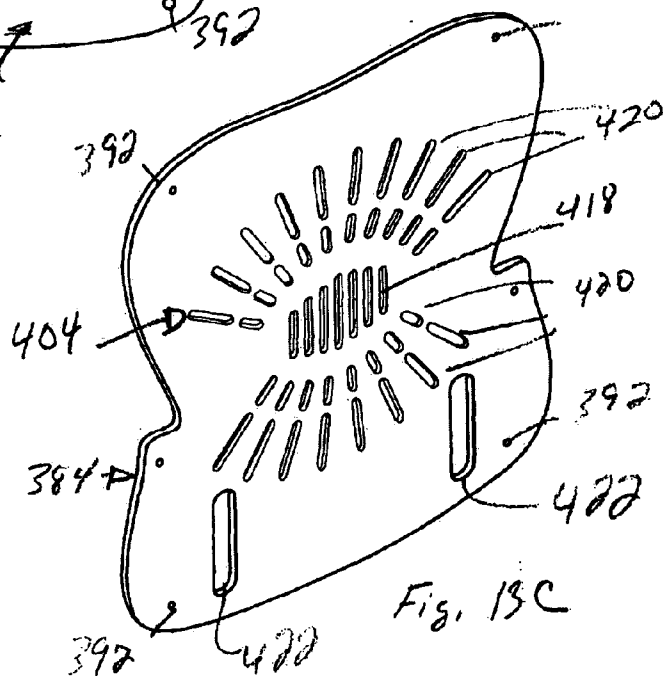
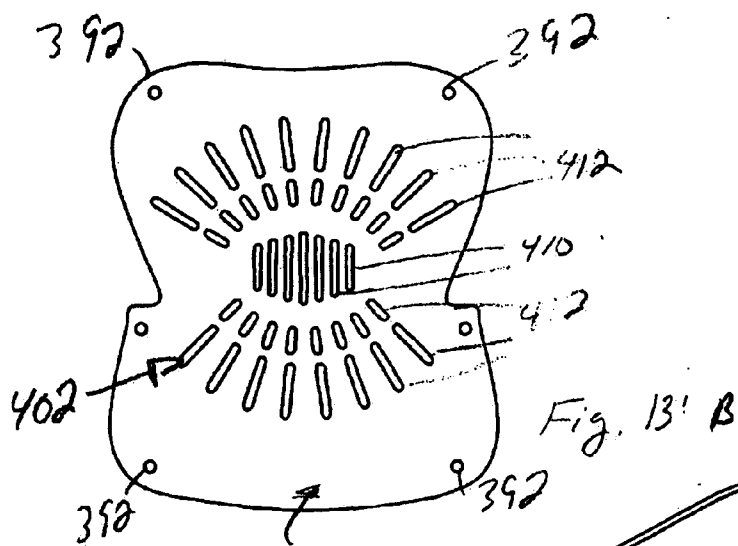

Fig. 11



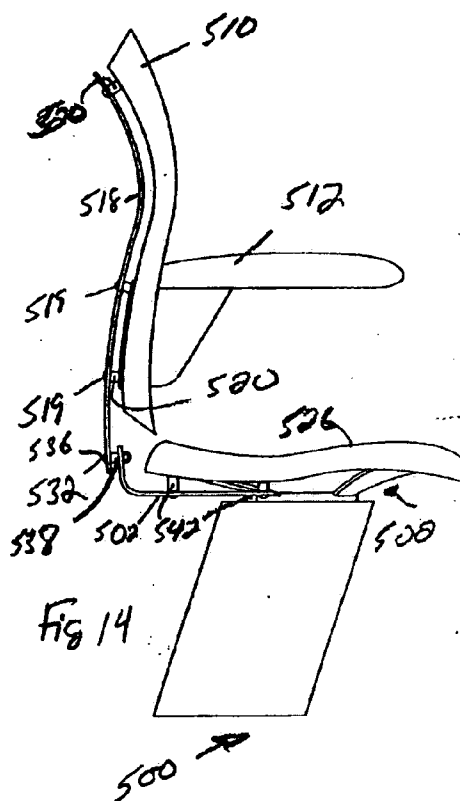

Fig. 14

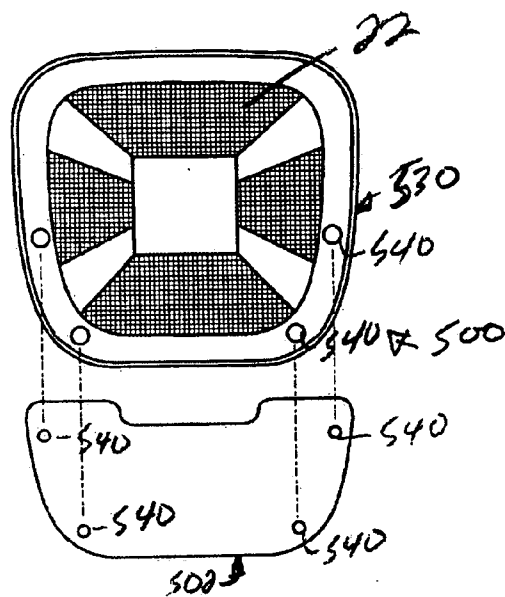

Fig. 15

VEHICLE SEAT WITH ADJUSTABLE SUPPORT SYSTEM

RELATED APPLICATIONS

[0001] The present patent document claims the benefit of the filing date under 35 U.S.C. §119(e) of provisional U.S. patent application Ser. No. 60/517,311, filed Nov. 3, 2003, which is hereby incorporated by reference.

FIELD OF THE INVENTION

[0002] The present invention relates generally to an elastomeric seating system. More particularly, the present invention relates to an elastomeric seating system having elements such as an elastomeric headrest, a metal support frame and a backrest/seat cover.

BACKGROUND

[0003] The present invention relates generally to seat components. More particularly, this invention pertains to a seating structure and/or components attached to a seat incorporating an elastomeric membrane.

[0004] Office chairs typically include a rigid frame surrounded by a single-layer or multi-layer foam and then covered with cloth, leather or the like. This type of upholstered seating creates a deformable cushion which conforms to the user's body. These upholstered seats are often used in automobiles, airlines, marine applications, office furniture and other known applications.

[0005] A woven fabric such as an elastomeric membrane for use in a seating structure has been disclosed in U.S. Pat. No. 6,035,901 and related patents assigned to Herman Miller Inc. This seating structure has greatly enhanced the comfort of office chairs. The use of an elastomeric membrane represents an improvement over upholstered seats. An elastomeric membrane can more readily distribute a person's weight as they adjust their seated position, and provides more aeration in order to keep the body cooler by dissipating more body heat. In the event of damage to the seat, the flexible membrane seating structure can be easier to repair or replace than an upholstered seat. While this flexible membrane technology continues to be highly useful for office seating structures, there are other applications in which an elastomeric membrane would be useful. For example, an elastomeric seat is lighter than many conventional seats and therefore has inherent advantages for many new applications. Also, there is a need for the use of a flexible membrane in seating structures designed for purposes other than office seating.

SUMMARY OF THE INVENTION

[0006] The present invention is directed to an elastomeric seating system that supports various functional elements.

[0007] According to one aspect of the invention, a headrest for supporting the head of a user is provided. A carrier member having a central opening is connected to the headrest. An elastomeric membrane having an edge portion is connected to the carrier member and covers the central opening.

[0008] According to another aspect of the present invention, a seating structure is provided for use with an elastomeric membrane and an edge portion. A carrier member is

also provided having a central opening. The edge portion of the elastomeric membrane is connected to the carrier member and covers the central opening. A metal support frame is connected to the carrier member.

[0009] According to another aspect of the invention, a seating structure is provided having a backrest, a first elastomeric membrane and a second elastomeric membrane. The first elastomeric membrane and the second elastomeric membrane each have an edge portion. The first elastomeric membrane is connected to the seat and the second elastomeric membrane is connected to the backrest. A first cover is connected to one of the seat and the backrest.

[0010] As used herein the term "connected to" is intended to be interpreted broadly and to include direct and indirect connections.

[0011] As used herein the term "seating structure" is intended to be interpreted broadly and to include seating uses in transportation applications such as automobiles, aircraft, watercraft, wheelchairs or other uses such as fixed seating in auditoriums, traditional office seating and residential uses.

[0012] The present invention, together with attendant objects and advantages, will be best understood with reference to the detailed description below in connection with the attached drawings.

BRIEF DESCRIPTION OF THE DRAWINGS

[0013] FIG. 1 is a front view of a headrest in accordance with a first embodiment of the present invention;

[0014] FIG. 2 is a rear view of a headrest in accordance with the embodiment of FIG. 1;

[0015] FIG. 3 is a side view of the headrest as shown in FIG. 2;

[0016] FIG. 4 is a rear view of the headrest adjustment mechanism as shown in FIGS. 2-3;

[0017] FIG. 5 is a rear view of a second embodiment of the headrest;

[0018] FIG. 6 is an exploded view of an embodiment of a support mechanism for the headrest;

[0019] FIG. 7 is an upper perspective view of a third embodiment of the headrest of the present invention;

[0020] FIG. 8 is a front perspective view of an embodiment of an elastomeric seating structure of the present invention with a metal support housing;

[0021] FIG. 9 is an exploded view of a carrier member;

[0022] FIGS. 10A & B illustrate embodiments of a portion of the support housing;

[0023] FIG. 11 is a perspective view of an elastomeric seating structure according to another embodiment of the present invention illustrated in an automobile;

[0024] FIG. 12 is rear perspective view of another embodiment of an elastomeric seating structure illustrated in an automobile;

[0025] FIGS. 13 A-C illustrate three embodiments of a backrest cover with FIG. 13A illustrating the backrest cover in an exploded relationship with respect to the backrest;

[0026] FIG. 14 is an illustration of a seating structure according to another embodiment of the present invention; and

[0027] FIG. 15 is an exploded view of a support plate and seat cover as shown in FIG. 14.

DETAILED DESCRIPTION OF THE PREFERRED EMBODIMENTS

[0028] The invention is described with reference to the drawings in which like elements are referred to by like numerals. The relationship and functioning of the various elements of this invention are better understood by the following detailed description. However, the embodiments of this invention as described below are by way of example only, and the invention is not limited to the embodiments illustrated in the drawings. It should also be understood that the drawings are not to scale and in certain instances details have been omitted which are not necessary for an understanding of the present invention, such as conventional details of fabrication and assembly. In addition, like elements have been numbered identically in the different embodiments.

[0029] FIGS. 1-7 illustrate elastomeric headrests 10, 12, 14 according to three embodiments of the present invention. The elastomeric headrests 10, 12, 14 of the present invention have a number of advantages. For example, the elastomeric headrest 10 provides greater comfort for the head of a user while also providing for aeration to more readily dissipate heat. In addition, the headrest 10 has less weight than many conventional headrests and can be more economically manufactured. By having less weight, the headrest 10 (in combination with the other elastomeric elements, e.g., the seat and backrest) can help provide increased fuel economy in an automobile or other vehicle. Further, the headrest 10 does not block visual access and is also readily cleaned.

[0030] The first embodiment of the elastomeric headrest 10 is illustrated in FIG. 1. The headrest 10 includes a carrier member 20 and elastomeric material 22. For a further description of the elastomeric material 22, reference is made to U.S. Pat. No. 6,035,901, entitled "Woven Seating Fabric For a Seating Surface" filed in the names of William Stumpf et al. and issued on Mar. 14, 2000, the disclosure of which is hereby incorporated by reference. In one embodiment, the elastomeric material 22 is molded to the carrier member 20. However, it should be recognized that alternate known attachment methods may be used to secure the elastomeric material 22 to the carrier member 20.

[0031] FIGS. 2-4 illustrate side and rear views of the elastomeric headrest 10 and the adjustment structure 30. The adjustment structure 30 includes a body 40 connected to the carrier member 20 at a pivotable connection point 42. A support rod mechanism 44, as best illustrated in FIG. 4, allows the body 40 to slide upward or downward therefrom in order to adjust the height of the elastomeric headrest 10 relative to a base structure. A conventional button 48 is used to secure the body 40 in a position selected by the user. In one embodiment, a conventional spring clip is used to secure the support rod mechanism 44 in the selected location. A rod 50 is connected to opposing ends of the carrier member 20 and connects to the body 40 at the pivotable connection point 42. Conventional clips 54 are used to secure the rod 50 to the carrier 20. The rod 50 may be formed from known

materials such as plastic or metal. As a result, the elastomeric headrest 10 can be height-adjusted to suit the need of a user. In addition, as best illustrated in FIG. 3, the elastomeric headrest 10 may be pivoted into an angular position selected by the user. It should also be recognized, however, that elastomeric headrest 10 may also be used with a fixed support column and/or fixed angular positioning mechanism.

[0032] With particular reference to FIG. 3, the carrier member 20 has a generally inverted C-shape in the illustrated embodiment. The shape and pivotable movement of the elastomeric headrest 10 allows it to pivot back as a user moves their head backwards. Accordingly, the headrest 10 provides a "rolling" support for the head of user as their head moves backwards such as when they move to a reclining position.

[0033] FIGS. 5-6 illustrate a second embodiment of an elastomeric headrest 12 according to the present invention. The elastomeric headrest 12 is constructed in the same general manner and operates similarly to the elastomeric headrest 10. However, the elastomeric headrest 12 has a slightly different adjustment structure 60. The adjustment structure 60 includes wing portions 62, 64 that connect to the ends of carrier member 22. A pivotable rod (not shown) passes through interior channel 70 within the adjustment structure 60. The channel 70 is best illustrated in FIG. 6 where the adjustment structure 60 is shown in an exploded view illustrating sides 60A, 60B. Conventional clips 71 are connected to the rod and secure it to the carrier 20. A support rod mechanism 72, as best illustrated in FIG. 5, allows the body 74 to slide upward or downward therefrom in order to adjust the height of the elastomeric headrest 12 relative to a base structure. The channels 76 (FIG. 6) engage the support rod mechanism 72. A conventional button 78 is used to secure the body 74 in a position selected by the user. A conventional spring clip could be used with the button 78 to selectively engage the support rod mechanism 72.

[0034] FIG. 7 illustrates a third embodiment of an elastomeric headrest 14 according to the present invention. The elastomeric headrest 14 is constructed in the same general manner and operates similarly to the elastomeric headrest embodiments 10, 12. However, the elastomeric headrest 14 has a slightly different adjustment structure 100. The adjustment structure 100 includes curved opposing portions 102, 104 that connect to intermediate position 110 and 112 on the carrier member 114. The carrier member 114 includes a tab 120 that is pivotably connected to the connector 122 on the adjustment structure 100. The elastomeric headrest 14 is pivotable in a lateral direction to suit the needs of a particular user. The elastomeric material 22 is the same material as described above.

[0035] It should be recognized that the headrest could be molded as a complete structure or that a contoured ring (plastic or metal) could comprise the perimeter of the carrier. This structure would also provide a different aesthetic appearance for the headrest. The elastomeric material could also be prestretched and molded to the carrier with a desired contour with tension coming from the shrinking of the carrier during the molding process. An alternate approach includes molding the elastomeric material and carrier as a two-dimensional ring piece which does not require prestretching. A perimeter ring would be attached to the carrier in order to

thereby stretch the elastomeric material. It should be further recognized that other attachment methods, as known to those of ordinary skill in the art may be used.

[0036] FIGS. 8-10 illustrate an embodiment of an elastomeric seating structure 200 having a rigid (preferably a material such as aluminum, steel magnesium, carbon fiber or other known materials) support frame 202. The support frame 202 or under structure is intended to be fixedly secured to a base structure. In particular, the use of an elastomeric seating structure 200 is appropriate for many applications such as motor vehicle seating, aircraft seating, watercraft or marine seating or other known applications where a rigid base structure is necessary. The seating structure 200 includes carrier members 204, 206 connected to elastomeric materials 22 as described and referenced herein. FIG. 8 also illustrates an adjustable back support element such as a lumbar support 210. It should also be noted that the elastomeric material in the carrier member 204 allows a user to have visual access to beneath the seating structure. This advantage is useful in many applications such as an aircraft.

[0037] As illustrated in FIG. 9, the carrier member 204 includes a top portion 218 and a bottom portion 220. The carrier member 204 may be formed from conventional materials such as known standard or high performance materials such as carbon fiber materials or resin materials. The top portion 218 includes a fastener receiving element or boss 219. The bottom portion 220 includes integral columns 222 molded therein. The columns 222 include a channel 224 adapted to receive a fastening element such as a screw.

[0038] FIGS. 10A & B illustrate the attachment of the carrier member 204 to the support frame 202. The support frame 202 includes a top portion 230 having apertures 232 formed in the legs 234. A support perimeter 236 interconnects the legs 234. FIG. 10B illustrates a fastening element such as a bolt 240 that is received within the boss 242. The boss 242 is fit within the aperture 232. The aperture 232 is threaded so as to receive the bolt 240. Accordingly, the bolt 240 passes through the channel 224 of the bottom portion 220 of the carrier member 204 and into the support frame 202, particularly the aperture 232, thereby securing the assembly together.

[0039] It should also be recognized that the metal frame could be formed with a raised edge equal in height to the carrier 204. The carrier 204 could then nest within the metal frame thereby providing additional structural strength to the seating structure. The back carrier 206 could also be secured through a metal seat back. Also, a fascia cover such as a soft molded material with padding could be applied to the perimeter of the support structure 202 in order to provide additional support and comfort without compromising the advantages of the elastomeric material 22.

[0040] FIG. 11 illustrates an embodiment of an elastomeric seating structure 300 in a vehicle application, particularly an automobile. The seating structure 300 includes carrier members 302, 304 with elastomeric material 22. A rigid support frame 310 is used to secure the carrier member 302 to a base structure. Rear support brackets 312 interconnect the seat carrier 302 to the back carrier 304. Headrest 320 is connected to a top portion 322 of the back carrier 304. The seating structure 300 is constructed using essentially the same elements as described above. It should be recognized that various known attachment methods and materials could be used to secure the seating structure 300.

[0041] FIG. 12 illustrates another embodiment of a seating structure 350 in a vehicle application. The seating structure 350 is constructed and operates in essentially the same manner as does the embodiment 300 except for the use of a shroud or cover 352. The cover 352 extends over the rear surface 354 of the seat back 356 and is generally contoured to fit the rear surface 354. The cover 352 acts to protect the rear surface 354 from accidental bumping or kicking. While the illustrated embodiment is directed at an automobile, the cover 352 is useful in any application where the rear surface 354 should be protected such as in aircraft, auditoriums or public seating.

[0042] The cover 352 includes a perimeter 360 and a plurality of apertures 362. The apertures 362 are sized to receive a fastening element such as a screw which will be further described herein. A plurality of vents 366 extend somewhat radially outward in the illustrated embodiment. The vents 366 allow for the seating structure 350 to retain the advantages of heat dissipation and aeration obtained by using an elastomeric material 22.

[0043] FIGS. 13A-C illustrate alternate embodiments of the covers 380, 382, 384. FIG. 13A illustrates one embodiment for the connection of the cover 380 to a seat back 390. The cover 380 includes apertures 392 sized to receive a fastening element such as a screw. Spacers 394 are located behind the apertures 392 and connect to the threaded holes 398. The spacers 394 include a channel adapted to receive the fastening element. Accordingly, a fastener connects the assembly together by passing through the apertures 392 and the channel in the spacer 394 and into the hole 398. Side vents 400 provide for additional air flow beneath the elastomeric material. In one embodiment, the spacers 394 have a length of approximately 1-2 inches. The use of spacers 394 is important because it allows pressure points on the elastomeric material to be distributed while also allowing air-flow beneath the elastomeric material 22.

[0044] FIGS. 13B & C illustrate covers 382, 384 constructed in accordance with additional embodiments. The covers 382, 384 operate in essentially the same manner as the embodiments described above except that alternate vent configurations 402, 404 are illustrated. The vent configuration 402 includes a plurality of laterally arranged slots or perforations 410 and a plurality of pairs of generally radially extending slots 412. The cover 404 includes similar slots 418 and 420 with side vents 422 also provided.

[0045] FIGS. 14 & 15 illustrate another embodiment of a seating structure 500 with a seat shroud or cover 502. The seat cover 502 protects the seat from inadvertent bumping and kicking in much the same way as the backrest cover described above. The seating structure 500 includes a backrest 510 and armrest 512. Backrest cover 518 is connected to the backrest 510 using a conventional fastening element 519 and spacers 520 as generally described above. The seat 526 includes a support plate 530 and the cover 502. The seat cover 502 is connected to the backrest cover 518 in the illustrated embodiment at the connector 532. The connector 532 includes a conventional fastening element 536 and a spacer 538. The connector 532 allows for a somewhat flexible connection thereby allowing the backrest 510 to flex. It should be recognized, however, that the seat cover 502 could be independently connected to the seat 526. The seat cover 502 is connected to the support plate 530 using a

conventional fastening element that passes through the apertures 540, spacers 542 and into the support plate 530. The seat cover 502 thereby protects the lower portion of the seat 526 while also allowing air flow therebeneath.

[0046] The embodiments described above and shown herein are illustrative and not restrictive. The scope of the invention is indicated by the claims rather than by the foregoing description and attached drawings. The invention may be embodied in other specific forms without departing from the spirit of the invention. For example, while an automobile application is illustrated in some of the figures, the present invention is useful in a wide variety of other known applications. Accordingly, these and any other changes which come within the scope of the claims are intended to be embraced herein.

I claim:

1. A headrest for supporting the head of a user, the headrest comprising:
 - a carrier member having a central opening;
 - an elastomeric membrane having an edge portion connected to the carrier member and covering the central opening.
2. The headrest of claim 1 wherein the elastomeric membrane is molded to the carrier member.
3. The headrest of claim 1 wherein the carrier member is contoured.
4. The headrest of claim 3 further comprising a support bracket.
5. The headrest of claim 4 wherein the support bracket is height adjustable.
6. The headrest of claim 5 wherein the elastomeric membrane is stretched.
7. The headrest of claim 6 further comprising a seating element connected to the support bracket.
8. The headrest of claim 7 wherein the elastomeric membrane is formed from multifilament yarn strands and monofilament strands.
9. The headrest of claim 8 wherein the multifilament yarn strands extend generally from a top to a bottom of the headrest and the monofilament strands extend generally from a first side to a second side of the headrest.
10. A seating structure comprising:
 - an elastomeric membrane having an edge portion;
 - a carrier member having a central opening, the edge portion of the elastomeric membrane being connected

- to the carrier member and covering the central opening; and
 - a metal support frame connected to the carrier member.
11. The seating structure of claim 10 wherein the elastomeric membrane is molded to the carrier member.
 12. The seating structure of claim 11 further comprising a fastener used to secure the carrier member to the support frame.
 13. The seating structure of claim 12 wherein the carrier member is contoured.
 14. The seating structure of claim 13 wherein the elastomeric membrane is formed from multifilament yarn strands and monofilament strands.
 15. The seating structure of claim 14 wherein the membrane is generally see-through.
 16. The seating structure of claim 15 wherein the membrane forms a portion of a backrest and a seat.
 17. The seating structure of claim 16 wherein the frame includes an opening generally corresponding to the opening of the carrier.
 18. The seating structure of claim 17 wherein the seating structure is secured to a base.
 19. The seating structure of claim 18 wherein the seating structure is movable along the base.
 20. A seating structure comprising:
 - a seat and backrest;
 - a first elastomeric membrane and a second elastomeric membrane each having an edge portion, the first elastomeric membrane being connected to the seat and the second elastomeric membrane being connected to the backrest;
 - a first cover connected to one of the seat and the backrest.
 21. The seating structure of claim 20 wherein a second cover is connected to the other of the seat and the backrest.
 22. The seating structure of claim 21 wherein the first cover and the second cover are attached at pivot points.
 23. The seating structure of claim 21 further comprising a fastener for connecting the first and second covers to the seat and the backrest.
 24. The seating structure of claim 23 wherein the fastener is a bolt.
 25. The seating structure of claim 26 wherein the membrane forms a portion of a seat.
 26. The seating structure of claim 25 wherein the cover is perforated.
 27. The seating structure of claim 26 wherein the first cover is connected to the seat and covers only a portion of the seat.

* * * * *