

Jan. 15, 1963

A. ZUKE

3,072,923

BATH SEAT

Filed March 23, 1961

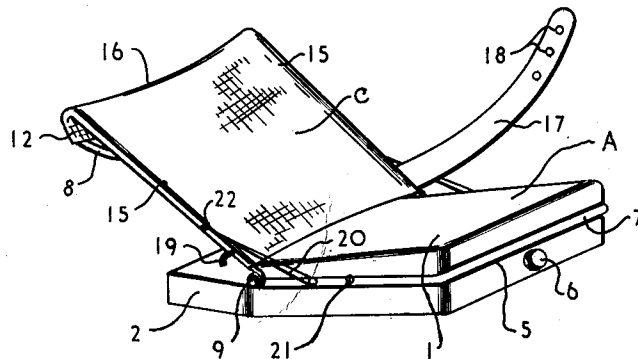

FIG. 1.

FIG. 3.

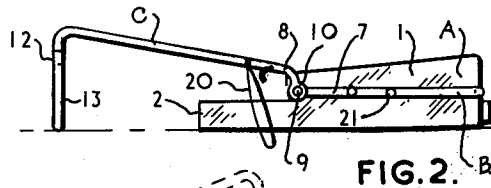
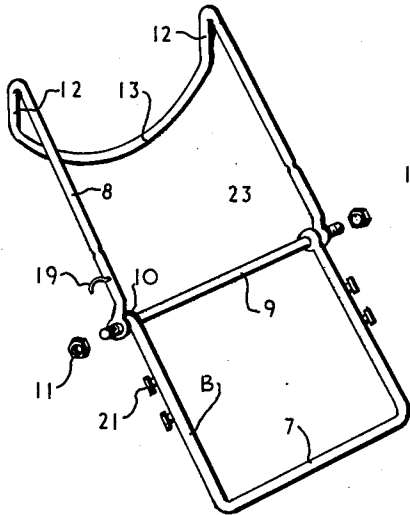

FIG. 2.

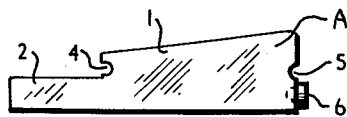

FIG. 5.

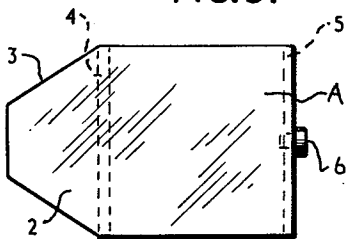

FIG. 6.

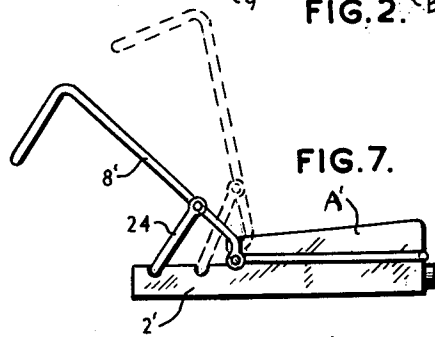

FIG. 7.

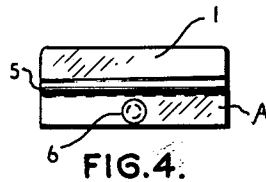

FIG. 4.

INVENTOR
AMELIA ZUKE

As Swin Hockett
ATTORNEY.

1

3,072,923
BATH SEAT
Amelia Zuke, Algoma, Ontario, Canada
(572 Shannon Road, Saulte Ste. Marie, Ontario, Canada)
Filed Mar. 23, 1961, Ser. No. 97,957
4 Claims. (Cl. 4-185)

This invention relates to improvements in a bath seat and appertains particularly to one for bathing an infant.

Usually the mother tries to hold the baby with one hand and to wash it with the other hand, a task made the more difficult because the soapy baby is slippery and tends to slide out of her grasp. Often undue splashing results and not infrequently the child gets soapy water in its face and eyes.

It is an object of the present invention to provide a baby's bath seat that is stable and in which an infant may be secured by a body-encircling strap.

A further object is to provide a baby's bath seat with an articulated frame allowing the child to be supported in either sitting or reclining position, yet assuring in the latter position that the child's head be held slightly elevated at all times and free of possible engagement with the bottom of the bath tub.

A further object of the invention is to provide a baby's bath seat with a novel comfortable and stable yet lightweight base on which the foldable frame may be releasably mounted, facilitating the fabrication, shipping and storage of the article.

A further object of the invention is to provide a baby's bath seat suitable for manufacture of synthetic plastic material or the like whereby an efficient and durable commodity may be produced at reasonable cost whereby the same is rendered commercially desirable.

To the accomplishment of these and related objects as shall become apparent as the description proceeds, the invention resides in the construction, combination and arrangement of parts as shall be hereinafter more fully described, illustrated in the accompanying drawings and pointed out in the claims hereunto appended.

The invention will be best understood and can be more clearly described when reference is had to the drawings forming a part of this disclosure wherein like characters indicate like parts throughout the several views.

In the drawings:

FIGURE 1 is a perspective elevation of a preferred embodiment of the seat with the back in elevated position;

FIGURE 2 is a side elevation of the same with the back in lowered or reclining position;

FIGURE 3 is a perspective elevation of the articulated frame parts, as in assembled position;

FIGURES 4, 5 and 6 are front, side and bottom views of the seat member; and

FIGURE 7 is a side elevation of a modified form of the invention.

The base member A has a raised or thickened seat portion 1 that occupies approximately the forward two-thirds of its length and though of generally rectangular shape the rearward extension 2 may be tapered in width as at 3. In the upward step where the seat portion 1 rises from the rearward extension 2 there is a transverse horizontal groove 4 running the full width thereof and across the front of the base member A there is a similar horizontal groove 5 running from side to side. I prefer to construct this base of strong soft plastic material such as polystyrene, synthetic rubber or the like and to make it hollow, provided with a filling port normally closed by a removable plug or screw cap 6. In this way a very comfortable yet lightweight base and seat is afforded that can be filled with water from the bath to increase its stability and as easily emptied for facility in storage or transportation; at other times it can be left in the bath.

2

Removably mounted on the base member A is an articulated frame B that supports an adjustable back rest. The frame comprises essentially three main parts; a seat yoke 7 in the form of a U, a back support yoke 8 also of U-shaped configuration and a transverse bar 9 that serves as a hinge pin for articulately connecting the said U-shaped yokes. To receive the transverse bar 9, the free end of both arms of each yoke is of eyelet form as seen at 10 and the bar is of sufficient length to extend through a pair of yoke arm eyelets at each end and carry a threaded nut or other fastener 11 therebeyond.

In applying the seat yoke 7 to the seat base member A, the bottom of the U is inserted in the groove 5 across the front of the base with the arms of the U-shaped yoke reaching to the back of the raised seat portion 1 where the transverse bar 9 fits in the groove 4 and runs through the yoke arm eyelets 10 securing the yoke 7 to the seat base A and hingedly attaching the back support yoke 8. An advantage is gained in forming the closed end of the said yoke 8 offset from the plane of the arms and so the arms near the closed end are each bent to lie at approximately right angles as at 12 and the intermediate portion or cross reach 13 is of arcuate form. Thus constructed the offset closed end of the back support yoke serves as a stop or rest to limit the rearward hinging of the yoke.

Completing the device is a back cover C of flexible material such as plastic with a sleeve portion 15 along opposite sides that receive the arms of the back support yoke 8 being applied thereto before the yoke is attached to the seat yoke by the hinge pin bar 9, and of such length that the back cover material extends from the seat 1 to and beyond the bend in the back support yoke arms so that the back cover rolls over at the top as shown at 16 to eliminate a sharp edge and provide a soft smooth support for the infant's head. A body belt 17 for strapping the child to the seat is attached to or formed integral with the seat cover C near the bottom at one side, its free end having a series of perforations 18 for selective engagement with a small hook 19 projecting laterally from the opposite arm of the back support yoke.

The back may be held in any of a number of positions such as upright or semi-upright by suitable adjustment of a tie or loop 20 carried by either or both arms of the back support yoke 8 and selectably engaging projections such as spaced buttons 21 along the arms of the seat yoke 7; slashes 22 in the sleeves at the side of the back cover C afford passage of the ties while grooves or notches 23 on the back support yoke arms that register with such slashes afford anchorage for the ties against slipping. In addition to the adjusted positions thus afforded the hinged back, it may be lowered into reclining position as shown in FIGURE 2 with the angular offset closed end of the yoke 8 resting on the bottom of the bath in which position it supports the child's head comfortably, at a slight elevation and clear of contact with the tub bottom.

In the modified form shown in FIGURE 7, the ties or loops are dispensed with and instead a bail 24 to the arms of the back support yoke 8' is set in a selected one of two or more transverse grooves in the top of the rearward extension 2' of seat base A'.

It has already been mentioned that the hollow seat base and the back cover are preferably though not necessarily made of plastic materials, so too the articulated frame may be of similar but stiffer substance; the advantage being that they will thereby be unaffected by wetting or immersion in water, as well as unable to cause hurt or injury to the baby or mother.

From the foregoing description taken in connection with the accompanying drawings, it will be manifest that a bath seat is provided that will fulfill all the necessary requirements of such a device, but as many changes could be made in the above description and many apparently

3

widely different embodiments of the invention may be constructed within the scope of the appended claims without departing from the spirit or scope thereof, it is intended that all matters contained in the said accompanying specification and drawings shall be interpreted as illustrative and not in a limitative or restrictive sense.

Having thus described the invention, what is claimed as new is:

1. A bath seat comprising a unitary base member having a forwardly extending upwardly stepped horizontally disposed portion constituting a seat and an integral rearwardly extending portion that is tapered in width and at a lower level than the seat portion, a seat yoke closely embracing the front and lateral walls of the seat, a back support yoke, a transverse bar engaging the rear wall of the seat and hingedly connecting the adjacent ends of the two yokes, the rearwardly extending portion of the base underlying the back yoke, means for securing the back support yoke in inclined position and a back cover secured to the back support yoke.

2. A bath seat comprising a base having a forwardly extending upwardly stepped hollow portion constituting a raised seat provided with an opening and a closure for the opening, the base being formed with a rearwardly extending integral portion of lesser height than the seat portion, transverse grooves in the front and rear walls of the seat, a seat yoke embracing the front and lateral walls

4

of the seat and engaging the groove in the said front wall, a back yoke, a rod engaging the groove in the back wall of the seat and hingedly connecting the back yoke to the seat yoke, the back yoke overhanging the rearwardly extending portion of the base, means for retaining the back yoke in adjustable inclined position and a flexible back cover on the back yoke.

3. The bath seat claimed in claim 2 in which the back yoke is U-shaped and has its cross-reach remote from said hingedly connecting rod, of arcuate form.

4. The bath seat claimed in claim 2 in which the rearwardly extending portion of the base that is lower than the seat and the transverse groove in the rear wall of the seat is located adjacent the junction of the rearwardly extending portion and the seat.

References Cited in the file of this patent

UNITED STATES PATENTS

2,133,223	Brightman et al. _____	Oct. 11, 1938
2,463,049	Onsa _____	Mar. 1, 1949
2,647,561	Szabo _____	Aug. 4, 1953
2,697,480	DuBois et al. _____	Dec. 21, 1954

FOREIGN PATENTS

12,775	Austria _____	July 5, 1903
245,217	Switzerland _____	July 1, 1947