

(19)



(11)

EP 4 098 374 B1

(12)

EUROPEAN PATENT SPECIFICATION

(45) Date of publication and mention of the grant of the patent:
05.02.2025 Bulletin 2025/06

(51) International Patent Classification (IPC):
B05C 5/02 ^(2006.01) **B28B 11/04** ^(2006.01)
B28B 17/00 ^(2006.01)

(21) Application number: **22185382.3**

(52) Cooperative Patent Classification (CPC):
B05C 5/0233; B28B 11/044; B28B 11/047;
B28B 17/0081; B05C 5/0245

(22) Date of filing: **14.12.2018**

(54) **EQUIPMENT FOR THE ENAMELING OF MANUFACTURED ARTICLES**

AUSRÜSTUNG ZUM EMAILLIEREN HERGESTELLTER GEGENSTÄNDE

ÉQUIPEMENT POUR L'ÉMAILLEGE DES ARTICLES MANUFACTURÉS

(84) Designated Contracting States:
AL AT BE BG CH CY CZ DE DK EE ES FI FR GB GR HR HU IE IS IT LI LT LU LV MC MK MT NL NO PL PT RO RS SE SI SK SM TR

(72) Inventors:
• **ELMETTI, Valdo Vittorio**
41042 Fiorano Modenese (MO) (IT)
• **FIANDRI, Giancarlo**
41042 Fiorano Modenese (MO) (IT)

(43) Date of publication of application:
07.12.2022 Bulletin 2022/49

(74) Representative: **Zoli, Filippo**
Brunacci & Partners S.r.l.
Via Pietro Giardini, 625
41125 Modena (IT)

(62) Document number(s) of the earlier application(s) in accordance with Art. 76 EPC:
18842728.0 / 3 894 092

(73) Proprietor: **TECNO ITALIA DIGITAL S.r.l.**
41042 Fiorano Modenese (MO) (IT)

(56) References cited:
WO-A1-2017/209926 US-A1- 2005 241 574
US-B1- 6 464 785

EP 4 098 374 B1

Note: Within nine months of the publication of the mention of the grant of the European patent in the European Patent Bulletin, any person may give notice to the European Patent Office of opposition to that patent, in accordance with the Implementing Regulations. Notice of opposition shall not be deemed to have been filed until the opposition fee has been paid. (Art. 99(1) European Patent Convention).

Description

Technical Field

[0001] The present invention relates to a piece of equipment for the enameling of manufactured articles.

Background Art

[0002] In the ceramic field, different methods for applying enamel to tiles are well known.

[0003] A first known method involves the use of a device, in jargon called "bell", which allows the formation of a film of enamel under which the tile is passed. This first methodology has however a number of drawbacks.

[0004] First of all, it involves the extensive use of enamel to maintain the continuity of the film which, besides entailing a high cost, also involves a significant increase in the weight of the tile. For this reason, the use of the bell is not very suitable for enameling tiles made using the single-firing process which, as is well known, require a low quantity and weight of enamel.

[0005] Another drawback of this first known method is the difficulty of applying enamel uniformly on the tiles. In fact, the quantity of applied enamel is greater at the edges of the tile and lesser in the central area.

[0006] Last but not least, in order to cover the entire tile surface, the film defined by the bell must have a greater extension than the tile itself, which entails a considerable waste of material. The enamel which falls outside the tile is generally recovered and reused. However, the recovered enamel has a different density than the original enamel, thus giving rise to color shades which are different to the initial ones.

[0007] A second known method, defined in jargon as "airless", involves the application of the enamel by means of atomization. More specifically, this method is carried out by means of a plurality of nozzles which are adapted to atomize the enamel and which are arranged inside the relevant enameling booths.

[0008] However, this second known method also has a number of drawbacks.

[0009] It does in fact involve considerable material waste, even up to 50% of the dispensed material, which remains in suspension inside the relevant booth. To overcome these drawbacks, most of the booths currently used for this enameling method are provided with a suction system, complete with a relevant filter to avoid dispersion into the atmosphere of the particles of atomized enamel which remain in suspension inside. This, however, gives rise to further drawbacks, linked to the disposal of the enamel which accumulates in the filters and to the fact that the suctioned enamel, a percentage of which can be recovered and reused, has a different density than the one initially dispensed and, therefore, can give rise to different color shades.

[0010] Yet another drawback of this described second method consists in the fact that it is difficult, particularly for

medium-large sizes, to apply the enamel uniformly on the surface to be covered.

[0011] An enameling method of the type known in the ceramic industry to overcome the drawbacks of the aforementioned known methods provides for the application of enamel by means of a series of nozzles which are adapted to dispense a relevant strip of enamel on the manufactured article to be enameled of identical width, so that the adjacent strips join together to define a substantially homogeneous layer of enamel. Preferably, such nozzles are adapted to dispense enamel at a pressure below 1 bar, so as to allow the release of a substantially continuous thread of enamel and such as to define a strip of enamel on the manufactured article to be enameled.

[0012] These nozzles each comprise a relevant electronically-controllable shutter, which is adapted to open/close a relevant enamel exit opening.

[0013] However, this enameling method does also have a number of drawbacks.

[0014] In fact, the enamel applied in this way features a number of shadings in the areas where the dispensed strips are joined, which affects the quality and aesthetic result of the finished product.

[0015] Some equipment for the enameling of manufactured articles is known from US 2003/230647 and DE 4416747 patent documents.

[0016] In particular, US 2003/230647 describes an equipment comprising an internally hollow load-bearing body inside which is housed to measure a roller in turn provided with an internal cavity meant to receive the enamel to be dispensed. The load-bearing body is provided with a plurality of orifices for dispensing the enamel on the outside and the roller is in turn provided with a plurality of holes adapted to allow the transit of the enamel contained inside the roller itself towards the outside following their alignment with the above-mentioned orifices. Immediately downstream of each hole, the roller is also provided with a relevant protrusion adapted to close the orifices during its rotation around the relevant axis and pushed towards the internal wall of the load-bearing body by relevant elastic means.

[0017] US 2003/23064 does not allow uniform enameling of the relevant manufactured article to be decorated, inasmuch as, due to the presence and proximity of the holes and of the protrusions defined on the relevant roller, it involves the dispensing of a plurality of lines on the manufactured article itself. Such lines are then visible on the manufactured article and give it an irregular appearance.

[0018] The equipment covered by patent document US 2003/23064 also has the drawback that the orifices can become blocked during normal operation, compromising the correct exit of the enamel.

[0019] Patent document DE 4416747 describes an equipment for the enameling of manufactured articles comprising a hollow body, adapted to contain the enamel to be dispensed and provided with a plurality of orifices,

inside which a cylinder is housed in turn provided with a series of cavities, so that when such cavities reach the orifices the enamel comes out towards the outside.

[0020] The equipment described by patent document DE 4416747 does not however permit uniformly enameling the relevant manufactured article, inasmuch as, in this case too, the enamel comes out in the form of lines, thus affecting the aesthetic appearance of same.

[0021] WO 2017/209926 A1 discloses a coating apparatus for direct coatings with various shape comprising an internally hollow container comprising a dispensing zone defined on a lateral side and inside which a roller is housed, the roller being operable in rotation around a relevant axis for opening and close the orifices defined on the dispensing zone.

Description of the Invention

[0022] The main aim of the present invention is to provide a piece of equipment which allows overcoming the drawbacks of the aforementioned prior art.

[0023] In particular, the present invention aims at providing a piece of equipment which allows distributing the enamel uniformly over the surface of the relevant manufactured articles, thus obtaining a high surface quality and at the same time reducing material waste to the utmost.

[0024] Within this aim, one object of the present invention is to make a piece of equipment that allows managing the amplitude, the frequency and the position of the quantity of dispensed enamel in an easy and flexible way.

[0025] Another object of the present invention is to provide a piece of equipment which is simple to make and operate.

[0026] Not the least object of the equipment forming the subject of the present invention is to avoid the deposit and consolidation of the enamel and, at the same time, to prevent the orifices becoming blocked.

[0027] Yet another object is to provide a piece of equipment which does not require the use of suction systems for the disposal of the enamel particles which remain in the air after its application.

[0028] Another object of the present invention is to provide an equipment for the enameling of manufactured articles which allows overcoming the aforementioned drawbacks of the prior art within the scope of a simple, rational, easy, efficient to use and cost-effective solution.

[0029] The aforementioned objects are achieved by the present equipment according to claim 1.

Brief Description of the Drawings

[0030] Other characteristics and advantages of the present invention will become more evident from the description of a preferred, but not exclusive embodiment of a piece of equipment for the enameling of manufactured articles, illustrated by way of an indicative, but non-limiting example, in the attached drawings in which:

Figure 1 is an axonometric view of a piece of equipment according to the invention;

Figure 2 is an exploded view of the equipment of Figure 1;

Figure 3 is an axonometric view of a portion of the container of the equipment of Figure 1;

Figure 4 is an axonometric view of a portion of the roller of the equipment of Figure 1;

Figure 5 is an enlarged view of a detail of the roller of Figure 4;

Figure 6 is an axonometric view of a portion of the container of the equipment of Figure 1, in an alternative embodiment;

Figure 7 is a side elevation view of the roller of the equipment of Figure 1, in an alternative embodiment;

Figure 8 is a longitudinal section of the equipment of Figure 1;

Figure 9 is an enlarged view of a detail of Figure 8;

Figure 10 is a cross-section of the equipment of Figure 1;

Figure 11 is an enlarged view of a detail of Figure 10, with the orifices in the closed configuration;

Figure 12 is an enlarged view of a detail of Figure 10, with the orifices in the open configuration;

Figure 13 is an axonometric view of the equipment of Figure 1 during operation;

Figure 14 is an axonometric view of a piece of equipment according to the invention in a particular embodiment;

Figure 15 is an axonometric view of a piece of equipment according to the invention in a particular embodiment.

Embodiments of the Invention

[0031] With particular reference to these figures, reference numeral 1 globally indicates a piece of equipment for the enameling of manufactured articles, especially ceramic products.

[0032] According to the invention, the equipment 1 comprises an internally hollow container 2 for the collection of enamel to be applied on a manufactured article M, which is provided with at least one group of through orifices for the outflow of the enamel.

[0033] Advantageously, the container 2 is under pressure, e.g. between 0.5 bar and 3 bar. More specifically, the container 2 has one or more channels 12 for feeding the enamel inside it. By closing the orifices, it is also possible to make the enamel re-circulate inside the container 2 through the channels 12, the minimum number of which in this case must be two.

[0034] In the present description, the group of orifices defined on the container 2 is identified with the reference number 3, while the individual orifices are identified with the reference number 13.

[0035] Suitably, the container 2 is meant to be supported by a load-bearing frame 20 and the equipment 1 comprises movement means 10 for moving the manu-

factured article M to be enameled along a direction of forward movement V. The movement means 10 define a supporting surface of the manufactured article M placed below the orifices 13, and are composed e.g. of a plurality of motor-driven belts.

[0036] The container 2, of the hollow type, may have a cylindrical shape, in which case the group 3 of orifices 13 is preferably defined along its side wall, or it may have a box shape, in which case the group 3 of orifices 13 is defined on the wall delimiting the bottom of the container itself.

[0037] In the preferred embodiment shown in the illustrations, the container 2 has a box-shaped on the outside and internally has a circular section. Conveniently, the orifices 13 are defined at the portion of the side wall of the container 2 arranged, in use, downwards.

[0038] The container 2 therefore has a relevant axis, corresponding to its internal axis. The axis of the container 2, identified in the illustrations with Y, therefore corresponds to the axis passing through the center of its internal circular section and to its longitudinal axis.

[0039] Inside the container 2 is housed at least one roller 4 operable in rotation around a relevant axis, identified in the figures by X.

[0040] According to the invention, the roller 4 is out of axis with respect to the container 2, i.e. the axis X is misaligned with respect to the axis Y.

[0041] The volume interposed between the inner walls of the container 2 and the roller 4 defines a containment chamber 8 of the enamel.

[0042] Advantageously, the section of the containment chamber 8 is decreasing towards the orifices 13. In other words, the volume of the containment chamber 8 decreases moving downwards. This means that the enamel is collected at the lower section area of the containment chamber 8, near the orifices 13, thus facilitating its exit following the opening of the orifices themselves.

[0043] According to the invention, furthermore, the orifices 13, which face onto the inside of the containment chamber 8, protrude inside it. In other words, the orifices 13 have a portion which extends towards the inside of the containment chamber 8, and this results in a discontinuity with respect to the wall which delimits the containment chamber itself or with respect to the inner side wall of the container 2.

[0044] The roller 4 is provided with a plurality of protrusions adapted to open and close the orifices 13 during the rotation of the roller itself, so as to allow and prevent respectively the enamel from flowing out of the container 2. In the present description, the set of protrusions defined on the roller 4 is identified with reference numeral 5, while the individual protrusions are identified with reference numeral 15.

[0045] In other words, during the rotation of the roller 4 around the axis X, the protrusions 15 reach the orifices 13, overlapping these so as to obstruct the transit of the enamel, and then, again following the rotation of the roller 4, move in order to reopen them.

[0046] The fact that the orifices 13 are protruding towards the inside of the containment chamber 8 makes it possible both to ensure that they close following the overlapping of the protrusions 15, which only interact with the orifices themselves, and at the same time, that there is no interaction, and therefore friction, between the protrusions 15 and the inner wall of the container 2.

[0047] The protrusions 15 then slide on the top of the orifices 13, obstructing the access mouth thereof. The trajectory covered by the protrusions 15 is therefore substantially tangential to the top of the orifices 13. In other words, during the rotation of the roller 4, the protrusions 15 "sweep" the access mouth of the orifices 13 removing any lumps of enamel that could be deposited on the mouth and creating an effect of mixing of the enamel which prevents the sedimentation thereof.

[0048] The roller 4 is opportunely made of elastomeric material, in order to allow the deformation of the protrusions 15 following the interaction with the orifices 13 and, thereby, ensuring the closure thereof.

[0049] Preferably, the equipment 1 comprises adjustment means for adjusting the position of the axis X of the roller 4 with respect to the container 2. The adjustment means therefore allow modifying the position of the axis X with respect to the axis Y of the container 2, e.g. so as to compensate for any closing inaccuracies due to the wear of the parts.

[0050] The adjustment means can be of the mechanical type, e.g. by means of register screws or other solutions known to the person skilled in the art, or, alternatively, of the electronic type.

[0051] Advantageously, the roller 4 is of the solid type. In other words, inside the roller 4 transit channels for the enamel or the like are not defined.

[0052] The orifices 13 can be closed either simultaneously, so that the internal volume of the container 2 is isolated from the outside and no enamel can come out, or sequentially, so that the orifices 13 are closed according to a predefined sequence during the rotation of the roller 4.

[0053] In the embodiment shown in the illustrations, each protrusion 15 is adapted to overlap a relevant orifice 13, obstructing it, when the set 5 of protrusions 15 reaches the group 3 of orifices 13.

[0054] More particularly, to each orifice 13 corresponds a relevant protrusion 15, so that there is therefore an instant when all the orifices 13 are closed by a relevant protrusion 15. The duration of the time interval wherein the orifices 13 remain closed depends on the rotation speed of the roller 4 and on the relevant sizes of the orifices and the protrusions themselves.

[0055] Preferably, the protrusions 15 are bigger than the orifices 13. The protrusions 15 can, e.g., have a parallelepiped section and the orifices 13 a circular section, although conformations of different types cannot be ruled out.

[0056] More particularly, the roller 4 has a plurality of recesses 11 defining the protrusions 15. The protrusions

15 are therefore defined by a series of recesses 11 obtained on the roller 4 and their external surface corresponds to the external surface of the roller itself, so they do not exceed its external diameter. The recesses 11 allow the transit of the enamel towards the orifices 13 during the rotation of the roller 4. More in detail, during the rotation of the roller 4, the enamel is pushed through the recesses 11 by the pressure.

[0057] The orifices 13 are therefore opened and closed as a result of the transit over these of the recesses 11 and of the protrusions 15, respectively.

[0058] Appropriately, the amplitude of the recesses 11, and therefore of the protrusions 15, determines the opening time of the orifices 13, the rotation speed of the roller 4 being equal.

[0059] In the embodiment of the equipment 1 shown in the illustrations, the group 3 of orifices 13 comprises at least one row 23 of orifices 13 extending along a first direction 6. The orifices 13 belonging to a same row 23 are therefore substantially aligned with each other (except for machining tolerances) along the same direction 6. Similarly, the set 5 of protrusions 15 also comprises at least one series 25 of protrusions 15 extending along the first direction 6, where the protrusions 15 arranged along each series 25 are substantially aligned (except for machining tolerances) along the first direction 6 with the orifices 13 arranged along at least one of the rows 23. The protrusions 15 are therefore arranged so as to be aligned with at least one relevant orifice 13 and to overlap them during the rotation of the roller 4.

[0060] Conveniently, the first direction 6 is substantially parallel to the axis X of rotation of the roller 4. In the embodiment shown in the illustrations, the first direction 6 is arranged transversely to the direction of forward movement V of the manufactured article M.

[0061] In more detail, since the contact between the roller 4 and the container 2 is of the linear type, in order for the protrusions 15 to be able to close the orifices 13 at the same time, these must be defined along a direction of the roller 4.

[0062] Preferably, the group 3 of orifices 13 and the set 5 of protrusions 15 comprise a plurality of rows 23 and a plurality of series 25 respectively, (two in this specific case, but embodiments cannot be ruled out wherein a greater number of rows 23 and series 25 is provided), where the number of series 25 is at least equal to the number of rows 23 and where the protrusions 15 of each series 25 are aligned along the first direction 6 with the orifices 13 of at least one relevant row 23, so that the protrusions 15 overlap to the orifices 13 when the set 5 of protrusions 15 reaches the group 3 of orifices 13.

[0063] It can therefore happen that the number of series 25 of the protrusions 15 is equal to the number of the rows 23 of orifices 13, e.g., two rows 23 and two series 25, or that the number of series 25 is greater than that of the rows 23, e.g., two rows 23 and three or four series 25, in order to increase the closing frequency of the orifices 13. As the number of series 25 or the number of

sets 5 increases, so does the number of times the orifices 13 are closed with each turn of the roller 4.

[0064] The closing time of the orifices 13 depends on their size and on the relevant protrusions 15, as well as on the rotation speed of the roller 4, the number of series 25 or of sets 5, as well as the rotation speed of the roller 4, affects the closing frequency of the orifices 13, i.e., the number of times the orifices 13 are closed in the unit of time.

[0065] Preferably, as in the embodiment shown in Figures 6 and 7, the orifices 13 arranged along one row 23 are staggered with respect to the orifices 13 of the adjacent rows 23 along a second direction 7 substantially orthogonal to the first direction 6. Similarly, the protrusions 15 arranged along a series 25 are staggered with respect to the protrusions 15 of the adjacent series 25 along the second direction 7, which is therefore arranged orthogonally to the axis X of the roller 4. It follows, therefore, that the first direction 6 defines a predefined angle α with the line joining the orifice/protrusion 13, 15 of a row/series 23, 25 with the nearest orifice/protrusion 13, 15 of the adjacent row/series 23, 25. This way, the dispensing areas of the enamel coming out of each row 23 of orifices 13 are staggered with respect to those of the adjacent rows 23, thus allowing more uniform enameling and a better coverage of the spaces compared to the case in which the dispensing areas obtained from the adjacent rows 23 are aligned with each other. The distance between the adjacent rows 23 (and therefore the amplitude of the angle α) defines the distance between the dispensing areas on the manufactured article M to be enameled along the second direction 7, while the rotation speed of the roller 4 and the sizes of the orifices 13 and of the protrusions 15, define instead the time in which the orifices 13 remain closed. The quantity of enamel dispensed by each orifice 13 depends instead on the opening time of the orifices 13, i.e. on the distance between the consecutive protrusions 15 responsible for closing the same orifice 13. Therefore, through the orifices 13, drops of enamel are dispensed which give rise to a substantially punctiform application on the manufactured article M. As the opening time of the orifices 13 increases, so does the size of the dispensed drop.

[0066] Figure 13 shows, schematically and by way of example, the distribution of the enameled areas on a manufactured article M. As can be seen, the enamel applied is of the punctiform type and the enameled areas recover the distribution of the orifices 13 defined on the container 2. By adjusting the parameters such as the rotation speed of the roller 4, the sizes of the orifices 13 and of the protrusions 15 and the forward movement speed of the manufactured article M, the quantity of enamel dispensed at each opening of the orifices 13 can be changed, as can the reciprocal distance of the points where the enamel is applied, so as to obtain uniform enameling both as regards the quantity of enamel dispensed on the surface of the manufactured article M and its distribution.

[0067] It should be noticed that during the enamel dispensing step on the manufactured article M the roller 4 rotates around the relevant axis X.

[0068] Advantageously, the roller 4 comprises a plurality of sets of protrusions 15 angularly spaced apart from one another along the circular extension of the roller itself.

[0069] Therefore, as already mentioned above, the angular distance between each set 5 of protrusions 15 also affects the closing frequency of the orifices 13. More in particular, the smaller the angular distance between a set 5 of protrusions 15 and the next set, the greater the closing frequency of the orifices 13, the rotation speed of the roller 4 being equal. In other words, the smaller the angular distance between one set 5 of protrusions 15 and the next set, the shorter the time that elapses between two successive closures of the orifices 13, the rotation speed of the roller 4 being equal, i.e., the shorter their opening time. The orifices 13 are therefore opened and closed in a sequential and cyclic way, i.e., with a determinate frequency, following the transit of each set 5 of protrusions 15 at the group 3 of orifices 13 defined on the container 2.

[0070] In the preferred embodiment shown in Figures 3, 4 and 5, the container 2 comprises a single row 23 of orifices 13 and a plurality of series 25 of protrusions 15 equally spaced the one from the other over the entire extension of the external surface of the roller 4. This specific arrangement of the orifices 13 and of the protrusions 15 makes it possible to apply a high number of enamel points on the manufactured article M and with a high frequency.

[0071] The Figures 11 and 12 identify the closing and opening positions of the orifices 13 respectively.

[0072] Advantageously, the equipment 1 comprises motor means 14 adapted to operate the roller 4 in rotation around the axis X. More in detail, such motor means 14 comprise electronic control means for controlling the rotation of the roller 4 around the axis X.

[0073] Suitably, the equipment 1 also comprises a command and control unit 9 adapted to command the start and movement of the motor means 14. More in particular, the equipment 1 comprises sensor means 16, e.g. of the type of a photocell, operationally connected to the command and control unit 9 and adapted to detect the position of the manufactured article M to be enameled in relation to the orifices 13. The command and control unit 9 is also operationally connected to the movement means 10 and is programmed so as to control the rotation of the roller 4 according to the position of the manufactured article M with respect to the orifices 13 and to its forward movement speed V so as to vary the quantity and/or frequency of the enamel dispensed through the orifices themselves.

[0074] More specifically, the command and control unit 9 is configured to command the rotation of the roller 4 following the detection of the transit of the manufactured article M to be enameled and to interrupt it once such

transit has been completed. The command and control unit 9 is therefore programmed to operate the roller 4 in rotation, thus allowing the enamel to be dispensed only when the manufactured article M passes below the orifices 13, thereby avoiding any waste of material. Opportunely, when the rear edge of the manufactured article M has passed beyond the orifices 13, the command and control unit 9 commands the interruption of enamel dispensing, blocking the rotation of the roller 4. More specifically, the command and control unit 9 stops the roller 4 in a position wherein the protrusions 15 block the orifices 13 to prevent the transit of the enamel.

[0075] At the same time, the command and control unit 9 is configured to adjust the rotation speed of the roller 4 according to the forward movement speed of the manufactured article M and to the type of application to be obtained. In particular, by increasing the rotation speed of the roller 4, the forward movement speed of the manufactured article M being equal, the quantity of enamel dispensed at each opening of the orifices 13 is reduced, i.e. the size is reduced of the relevant point applied on the manufactured article M, and at the same time the dispensing frequency is increased, i.e. the distance between two consecutive dispensing operations along the direction of forward movement V is reduced, so that the dispensed enamel points are closer to one another.

[0076] The operation of the present invention is as follows.

[0077] Depending on the width of the manufactured article M to be enameled, the equipment 1 with the most suitable dimensions is chosen or the closing means are adjusted in order to regulate the extension of the rows 23 of orifices 13 responsible for dispensing the enamel.

[0078] The container 2 is then fed with enamel at a substantially constant pressure, equal to about 1 bar, which is collected inside the containment chamber 8.

[0079] The rotation of the roller 4 is then synchronized by the command and control unit 9 with the forward movement of the manufactured article M to be enameled, so that the dispensing of the enamel through the orifices 13 starts when the manufactured article M reaches the orifices themselves and stops once it has passed them.

[0080] The command and control unit 9 also acts on the means of control of the rotation of the roller 4 to adjust its rotation speed, according to the forward movement speed of the manufactured article M, in such a way as to vary the quantity of dispensed enamel at each opening of the orifices 13 and the dispensing frequency, i.e. the distance between two successive dispensing operations along the direction of forward movement V.

[0081] Appropriately, the rotation speed of the roller 4 corresponds to the forward movement speed of the manufactured article M to be enameled.

[0082] Alternatively, the command and control unit 9 can intervene on the movement means 10 to vary the forward movement speed of the manufactured article M, the rotation speed of the roller 4 being equal.

[0083] As can be easily appreciated, as a result of the

pressure inside the container 2, the enamel comes out through the orifices 13, thus falling on the manufactured article M which transits below the orifices themselves.

[0084] The orifices 13 are then closed by the protrusions 15 by effect of the rotation of the roller 4. By effect of the rotation of the roller 4, the protrusions 15 interact with the top of the orifices 13, closing their access mouth facing inside the containment chamber 8.

[0085] More particularly, the rotation of the roller 4 conveys the sets 5 of protrusions to the group 3 of orifices 13 and, as soon as the protrusions 15 of each series 25 overlap the orifices 13 of the corresponding rows 23, the container 2 is without openings towards the outside so that the enamel does not come out.

[0086] As already mentioned above, the reciprocal position of the orifices 13 arranged in rows 23 adjacent to one another determines the position and the distance of the areas in which the enamel is dispensed, the sizes of the orifices 13 and of the relevant protrusions 15, as well as the rotation speed of the roller 4, determine the closing time of the orifices 13, the angular distance between the sets 5 of protrusions and the rotation speed of the roller 4 determine the opening/closing frequency of the orifices 13, the distance between two consecutive protrusions 15 determines the opening time of the corresponding orifice 13 and, therefore, the quantity of enamel dispensed.

[0087] It has in practice been ascertained that the described invention achieves the intended objects and, in particular, the fact is underlined that the equipment forming the subject of the present invention allows enameling a manufactured article in an effective and uniform manner.

[0088] The misalignment of the roller with respect to the container allows defining a chamber for the collection of enamel outside the roller itself and having a conformation such as to allow the collection of the enamel at the orifices, thus facilitating the exit thereof. At the same time, the shape of the orifices, protruding towards the inside of the containment chamber, ensures their correct and effective closure by the protrusions defined on the roller.

[0089] The equipment thus conceived allows the enamel to be applied in a punctiform manner on the manufactured article M to be enameled, so as to obtain, as a result of the natural expansion of the enamel thus dispensed on the relevant surface, a uniform enameling free of aesthetic defects.

[0090] In particular, by adjusting the process parameters, such as the position of the orifices and protrusions, the angular distance of the sets of protrusions and the rotation speed of the roller, it is possible to modify at will the size of the enamel drops dispensed and the distance between them.

[0091] Moreover, in order to vary the quantity of enamel applied to a manufactured article, it is necessary to adjust the enamel feeding pressure inside the containment chamber and the forward movement speed of the manufactured article itself.

[0092] The equipment according to the invention does

not therefore have any construction or manufacturing limits and is able to adapt easily to any production requirement.

[0093] Furthermore, the particular shape of the orifices, protruding towards the inside of the enamel containment chamber, and the closure "by rubbing" due to the tangential contact of the protrusions with the mouth of the orifices themselves, allows removing any residues or lumps of enamel that may deposit at this point. The rotary movement of the roller therefore makes it possible to keep the orifices free of any bodies that could obstruct the transit of the enamel.

[0094] At the same time, the shape of the containment chamber and the movement of the roller inside it allow the continuous mixing of the enamel, thus preventing this from depositing on the bottom and producing areas of different densities.

Claims

1. Equipment (1) for the enameling of manufactured articles, comprising:

an internally hollow container (2) for the collection of enamel to be applied on a manufactured article (M), where said container (2) is provided with at least one group (3) of through orifices (13) for the outflow of the enamel;

at least one roller (4) housed out of axis inside said container (2) and operable in rotation around a relevant axis (X),

electronic control means for controlling the rotation of said roller (4) around the relevant axis (X), where the volume interposed between the inner walls of said container (2) and said roller (4) defines a containment chamber (8) of the enamel, said orifices (13) protruding inside said containment chamber (8);

where said roller (4) is provided with at least one set (5) of protrusions (15) adapted to open and close said orifices (13) during the rotation of the roller itself to allow and prevent respectively the enamel from flowing out of said container (2) and wherein it comprises movement means (10) for moving the manufactured article (M) to be enameled along a direction of forward movement (V), sensor means (16), adapted to detect the position of the manufactured article (M) to be enameled in relation to said orifices (13) and by the fact that it comprises at least one command and control unit (9) which is operationally connected to said movement means (10), to said sensor means (16) and to said control means, where said command and control unit (9) is configured

to control the rotation speed of said roller (4) around the relevant axis according to the posi-

- tion of the manufactured article (M) with respect to said orifices (13) and to its forward movement speed so as to vary the quantity and/or frequency of the enamel dispensed through the orifices themselves, i.e. the distance between two successive dispensing operations along the direction of forward movement (V), or to control said movement means (10) to vary the forward movement speed of the manufactured article (M), the rotation speed of said roller (4) being equal, and **characterized by** the fact that said roller (4) comprises a plurality of said sets (5) of protrusions (15) angularly spaced apart from one another along the circular extension of the roller itself, said orifices (13) being opened and closed in a sequential and cyclic way, i.e., with a determinate frequency, following the transit of each set (5) of protrusions (15) at said group (3) of orifices (13) defined on the container (2), giving rise to a substantially punctiform application on the manufactured article (M).
2. Equipment (1) according to claim 1, **characterized by** the fact that each of said protrusions (15) overlaps a relevant orifice (13), obstructing it, when said set (5) of protrusions (15) reaches said group (3) of orifices (13).
 3. Equipment (1) according to claim 1 or 2, **characterized by** the fact that said set (5) of protrusions (15) is adapted to substantially close simultaneously said group (3) of orifices (13).
 4. Equipment (1) according to one or more of the preceding claims, **characterized by** the fact that said group (3) of orifices (13) comprises at least one row (23) of orifices (13) extending along a first direction (6), and by the fact that said set (5) of protrusions (15) comprises at least one series (25) of protrusions (15) extending along said first direction (6), the protrusions (15) arranged along each of said series (25) being substantially aligned along said first direction (6) with the orifices (13) arranged along at least one of said rows (23).
 5. Equipment (1) according to claim 4, **characterized by** the fact that said first direction (6) is substantially parallel to the axis of rotation of said roller (4).
 6. Equipment (1) according to claim 4 or 5, **characterized by** the fact that said group (3) of orifices (13) comprises a plurality of said rows (23) and said set (5) of protrusions (15) comprises a plurality of said series (25), where the number of said series (25) is at least equal to the number of said rows (23) and where the protrusions (15) of each of said series (25) are substantially aligned along said first direction (6) with the orifices (13) of at least one of said rows (23).
 7. Equipment (1) according to claim 6, **characterized by** the fact that the orifices (13) of one of said rows (23) are staggered with respect to the orifices (13) of the adjacent rows (23) along a second direction (7) substantially orthogonal to said first direction (6).
 8. Equipment (1) according to one or more of the preceding claims, **characterized by** the fact that said roller (4) has a plurality of recesses defining said protrusions (15).
 9. Equipment (1) according to one or more of the preceding claims, **characterized by** the fact that said protrusions (15) are bigger than said orifices (13).
 10. Equipment (1) according to one or more of the preceding claims, **characterized by** the fact that it comprises closure means for closing at least one part of said orifices (13) moveable along said first direction (6).
 11. Equipment (1) according to one or more of the preceding claims, **characterized by** the fact that the section of said containment chamber (8) is decreasing towards said orifices (13).
 12. Equipment (1) according to one or more of the preceding claims, **characterized by** the fact that it comprises adjustment means for adjusting the position of the axis of said roller (4) with respect to said container (2).
 13. Equipment (1) according to one or more of the preceding claims, **characterized by** the fact that said orifices (13) have a portion which extends towards the inside of said containment chamber (8), and this results in a discontinuity with respect to the wall which delimits the containment chamber itself or with respect to the inner side wall of said container (2) and by the fact that said orifices (13) are defined at the portion of the side wall of said container (2) arranged, in use, downwards.

Patentansprüche

1. Ausrüstung (1) zum Emaillieren von gefertigten Erzeugnissen, umfassend:
 - einen innen hohlen Behälter (2) zum Sammeln von Emaille, die auf ein gefertigtes Erzeugnis (M) aufgetragen werden soll, wobei der Behälter (2) mit mindestens einer Gruppe (3) von Durchgangsöffnungen (13) für den Ausfluss der Emaille versehen ist;

mindestens eine Walze (4), die achsversetzt in dem Behälter (2) untergebracht ist und um eine maßgebliche Achse (X) rotieren kann, elektronische Steuerungsmittel zur Steuerung der Rotation der Walze (4) um die maßgebliche Achse (X), wobei das zwischen den inneren Wänden des Behälters (2) und der Walze (4) eingeschlossene Volumen eine Aufnahmekammer (8) für die Emaillierung definiert und die Öffnungen (13) in die Aufnahmekammer (8) hineinragen; wobei die Walze (4) mit mindestens einem Satz (5) von Vorsprüngen (15) versehen ist, die dazu ausgebildet sind, die Öffnungen (13) während der Rotation der Walze selbst zu öffnen und zu schließen, um zu ermöglichen bzw. zu verhindern, dass die Emaillierung aus dem Behälter (2) fließt, und wobei sie Bewegungsmittel (10) zum Bewegen des gefertigten Erzeugnisses (M), das emailliert werden soll, entlang einer Richtung der Vorwärtsbewegung (V) umfasst, Sensormittel (16), die ausgebildet sind, um die Position des gefertigten Erzeugnisses (M), das emailliert werden soll, in Bezug auf die Öffnungen (13) zu erfassen, und durch die Tatsache dass sie mindestens eine Befehls- und Steuereinheit (9) umfasst, die in Wirkverbindung mit den Bewegungsmitteln (10), den Sensormitteln (16) und den Steuerungsmitteln steht, wobei die Befehls- und Steuereinheit (9) dazu ausgebildet ist, die Rotationsgeschwindigkeit der Walze (4) um die maßgebliche Achse entsprechend der Position des gefertigten Erzeugnisses (M) in Bezug auf die Öffnungen (13) und seiner Geschwindigkeit der Vorwärtsbewegung zu steuern, um die Menge und/oder die Frequenz der durch die Öffnungen selbst abgegebenen Emaillierung zu variieren, d.h. den Abstand zwischen zwei aufeinanderfolgenden Abgabevorgängen entlang der Richtung der Vorwärtsbewegung (V), oder um die Bewegungsmittel (10) zu steuern, um die Geschwindigkeit der Vorwärtsbewegung des gefertigten Erzeugnisses (M) zu variieren, wobei die Rotationsgeschwindigkeit der Walze (4) gleich ist, und **dadurch gekennzeichnet, dass** die Walze (4) eine Mehrzahl der Sätze (5) von Vorsprüngen (15) umfasst, die entlang der kreisförmigen Ausdehnung der Walze selbst in einem Winkel voneinander beabstandet sind, wobei die Öffnungen (13) auf sequentielle und zyklische Weise geöffnet und geschlossen werden, d. h. mit einer bestimmten Frequenz, nach dem Durchgang jedes Satzes (5) von Vorsprüngen (15) an der Gruppe (3) von Öffnungen (13), die auf dem Behälter (2) definiert sind, geöffnet und geschlossen werden, wodurch eine im Wesentli-

chen punktförmige Auftragung auf dem gefertigten Erzeugnis (M) entsteht.

2. Ausrüstung (1) gemäß Anspruch 1, **dadurch gekennzeichnet, dass** jeder der Vorsprünge (15) eine entsprechende Öffnung (13) überlappt und diese versperrt, wenn der Satz (5) von Vorsprüngen (15) die Gruppe (3) von Öffnungen (13) erreicht.
3. Ausrüstung (1) gemäß Anspruch 1 oder 2, **dadurch gekennzeichnet, dass** der Satz (5) von Vorsprüngen (15) dazu ausgebildet ist, die Gruppe (3) von Öffnungen (13) im Wesentlichen gleichzeitig zu verschließen.
4. Ausrüstung (1) gemäß einem oder mehreren der vorhergehenden Ansprüche, **dadurch gekennzeichnet, dass** die Gruppe (3) von Öffnungen (13) mindestens eine Reihe (23) von Öffnungen (13) umfasst, die sich entlang einer ersten Richtung (6) erstreckt, und dadurch, dass der Satz (5) von Vorsprüngen (15) mindestens eine Serie (25) von Vorsprüngen (15) umfasst, die sich entlang der ersten Richtung (6) erstreckt, wobei die Vorsprünge (15), die entlang jeder der Serien (25) angeordnet sind, im Wesentlichen entlang der ersten Richtung (6) mit den Öffnungen (13) ausgerichtet sind, die entlang mindestens einer der Reihen (23) angeordnet sind.
5. Ausrüstung (1) gemäß Anspruch 4, **dadurch gekennzeichnet, dass** die erste Richtung (6) im Wesentlichen parallel zur Rotationsachse der Walze (4) ist.
6. Ausrüstung (1) gemäß Anspruch 4 oder 5, **dadurch gekennzeichnet, dass** die Gruppe (3) von Öffnungen (13) eine Mehrzahl der Reihen (23) umfasst und der Satz (5) von Vorsprüngen (15) eine Mehrzahl der Serien (25) umfasst, wobei die Anzahl der Serien (25) mindestens gleich der Anzahl der Reihen (23) ist und wobei die Vorsprünge (15) jeder der Serien (25) im Wesentlichen entlang der ersten Richtung (6) mit den Öffnungen (13) mindestens einer der Reihen (23) ausgerichtet sind.
7. Ausrüstung (1) gemäß Anspruch 6, **dadurch gekennzeichnet, dass** die Öffnungen (13) einer der Reihen (23) in Bezug auf die Öffnungen (13) der benachbarten Reihen (23) entlang einer zweiten Richtung (7) im Wesentlichen orthogonal zu der ersten Richtung (6) versetzt sind.
8. Ausrüstung (1) gemäß einem oder mehreren der vorstehenden Ansprüche, **dadurch gekennzeichnet, dass** die Walze (4) eine Mehrzahl von Rücksprüngen aufweist, die die Vorsprünge (15) definieren.
9. Ausrüstung (1) gemäß einem oder mehreren der

vorstehenden Ansprüche, **dadurch gekennzeichnet, dass** die Vorsprünge (15) größer sind als die Öffnungen (13).

10. Ausrüstung (1) gemäß einem oder mehreren der vorhergehenden Ansprüche, **dadurch gekennzeichnet, dass** sie Verschlussmittel zum Verschließen mindestens eines Teils der Öffnungen (13) umfasst, die entlang der ersten Richtung (6) beweglich sind. 5 10
11. Ausrüstung (1) gemäß einem oder mehreren der vorstehenden Ansprüche, **dadurch gekennzeichnet, dass** der Querschnitt der Aufnahmekammer (8) zu den Öffnungen (13) hin abnimmt. 15
12. Ausrüstung (1) gemäß einem oder mehreren der vorstehenden Ansprüche, **dadurch gekennzeichnet, dass** sie Einstellmittel zum Einstellen der Position der Achse der Walze (4) in Bezug auf den Behälter (2) umfasst. 20
13. Ausrüstung (1) gemäß einem oder mehreren der vorhergehenden Ansprüche, **dadurch gekennzeichnet, dass** die Öffnungen (13) einen Abschnitt aufweisen, der sich in Richtung des Inneren der Aufnahmekammer (8) erstreckt, und dies zu einer Diskontinuität in Bezug auf die Wand führt, die die Aufnahmekammer selbst begrenzt, oder in Bezug auf die innere Seitenwand des Behälters (2) und dadurch, dass die Öffnungen (13) an dem Teil der Seitenwand des Behälters (2) definiert sind, der bei Verwendung nach unten zeigt. 25 30

Revendications

1. - Équipement (1) pour l'émaillage d'articles manufacturés, comprenant :

un contenant (2) intérieurement creux pour la collecte d'émail à appliquer sur un article manufacturé (M), ledit contenant (2) comportant au moins un groupe (3) d'orifices traversants (13) pour l'écoulement de sortie de l'émail ; 45

au moins un rouleau (4) reçu hors axe à l'intérieur dudit contenant (2) et apte à être actionné en rotation autour d'un axe (X) pertinent, des moyens de commande électronique pour commander la rotation dudit rouleau (4) autour de l'axe (X) pertinent, 50

le volume interposé entre les parois intérieures dudit contenant (2) et ledit rouleau (4) définissant une chambre de confinement (8) de l'émail, lesdits orifices (13) faisant saillie à l'intérieur de ladite chambre de confinement (8) ; 55

ledit rouleau (4) comportant au moins un ensemble (5) de saillies (15) agencées pour ouvrir et fermer lesdits orifices (13) pendant la rotation du rouleau lui-même pour permettre et empêcher respectivement l'émail de s'écouler hors dudit contenant (2), et l'équipement (1) comprenant des moyens de déplacement (10) pour déplacer l'article manufacturé (M) à émailler le long d'une direction de déplacement vers l'avant (V), des moyens de détection (16) agencés pour détecter la position de l'article manufacturé (M) à émailler par rapport auxdits orifices (13), et par le fait qu'il comprend au moins une unité de commande et de contrôle (9) qui est reliée de manière fonctionnelle auxdits moyens de déplacement (10), auxdits moyens de détection (16) et auxdits moyens de commande,

ladite unité de commande et de contrôle (9) étant configurée pour :

commander la vitesse de rotation dudit rouleau (4) autour de l'axe pertinent en fonction de la position de l'article manufacturé (M) par rapport auxdits orifices (13) et de sa vitesse de déplacement vers l'avant de façon à faire varier la quantité et/ou la fréquence de l'émail distribué à travers les orifices eux-mêmes, c'est-à-dire la distance entre deux opérations de distribution successives le long de la direction de déplacement vers l'avant (V), ou commander lesdits moyens de déplacement (10) pour faire varier la vitesse de déplacement vers l'avant de l'article manufacturé (M), la vitesse de rotation dudit rouleau (4) étant égale, et

caractérisé par le fait que ledit rouleau (4) comprend une pluralité desdits ensembles (5) de saillies (15) espacées angulairement les unes des autres le long de l'extension circulaire du rouleau lui-même, lesdits orifices (13) étant ouverts et fermés de manière séquentielle et cyclique, c'est-à-dire à une fréquence déterminée, suite au passage de chaque ensemble (5) de saillies (15) au niveau dudit groupe (3) d'orifices (13) définis sur le contenant (2), donnant lieu à une application sensiblement punctiforme sur l'article manufacturé (M).

2. - Équipement (1) selon la revendication 1, **caractérisé par le fait que** chacune desdites saillies (15) recouvre un orifice (13) correspondant, en l'obstruant, lorsque ledit ensemble (5) de saillies (15) atteint ledit groupe (3) d'orifices (13).

3. - Équipement (1) selon la revendication 1 ou 2, **caractérisé par le fait que** ledit ensemble (5) de saillies (15) est agencé pour sensiblement fermer simultanément ledit groupe (3) d'orifices (13).
4. - Équipement (1) selon une ou plusieurs des revendications précédentes, **caractérisé par le fait que** ledit groupe (3) d'orifices (13) comprend au moins une rangée (23) d'orifices (13) s'étendant le long d'une première direction (6), et **par le fait que** ledit ensemble (5) de saillies (15) comprend au moins une série (25) de saillies (15) s'étendant le long de ladite première direction (6), les saillies (15) disposées le long de chacune desdites séries (25) étant sensiblement alignées le long de ladite première direction (6) avec les orifices (13) disposés le long d'au moins l'une desdites rangées (23).
5. - Équipement (1) selon la revendication 4, **caractérisé par le fait que** ladite première direction (6) est sensiblement parallèle à l'axe de rotation dudit rouleau (4).
6. - Équipement (1) selon la revendication 4 ou 5, **caractérisé par le fait que** ledit groupe (3) d'orifices (13) comprend une pluralité desdites rangées (23) et ledit ensemble (5) de saillies (15) comprend une pluralité desdites séries (25), le nombre desdites séries (25) étant au moins égal au nombre desdites rangées (23), et les saillies (15) de chacune desdites séries (25) étant sensiblement alignées le long de ladite première direction (6) avec les orifices (13) d'au moins l'une desdites rangées (23).
7. - Équipement (1) selon la revendication 6, **caractérisé par le fait que** les orifices (13) de l'une desdites rangées (23) sont décalés par rapport aux orifices (13) des rangées (23) adjacentes le long d'une seconde direction (7) sensiblement orthogonale à ladite première direction (6).
8. - Équipement (1) selon une ou plusieurs des revendications précédentes, **caractérisé par le fait que** ledit rouleau (4) a une pluralité d'évidements définissant lesdites saillies (15).
9. - Équipement (1) selon une ou plusieurs des revendications précédentes, **caractérisé par le fait que** lesdites saillies (15) sont plus grosses que lesdits orifices (13).
10. - Équipement (1) selon une ou plusieurs des revendications précédentes, **caractérisé par le fait qu'il** comprend des moyens de fermeture pour fermer au moins une partie desdits orifices (13) mobiles le long de ladite première direction (6).
11. - Équipement (1) selon une ou plusieurs des revendications précédentes, **caractérisé par le fait que** la section de ladite chambre de confinement (8) est décroissante vers lesdits orifices (13).
12. - Équipement (1) selon une ou plusieurs des revendications précédentes, **caractérisé par le fait qu'il** comprend des moyens de réglage pour régler la position de l'axe dudit rouleau (4) par rapport audit contenant (2).
13. - Équipement (1) selon une ou plusieurs des revendications précédentes, **caractérisé par le fait que** lesdits orifices (13) ont une portion qui s'étend vers l'intérieur de ladite chambre de confinement (8), ce qui résulte en une discontinuité par rapport à la paroi qui délimite la chambre de confinement elle-même ou par rapport à la paroi latérale intérieure dudit contenant (2), et **par le fait que** lesdits orifices (13) sont définis à la portion de la paroi latérale dudit contenant (2) disposée, en utilisation, en bas.

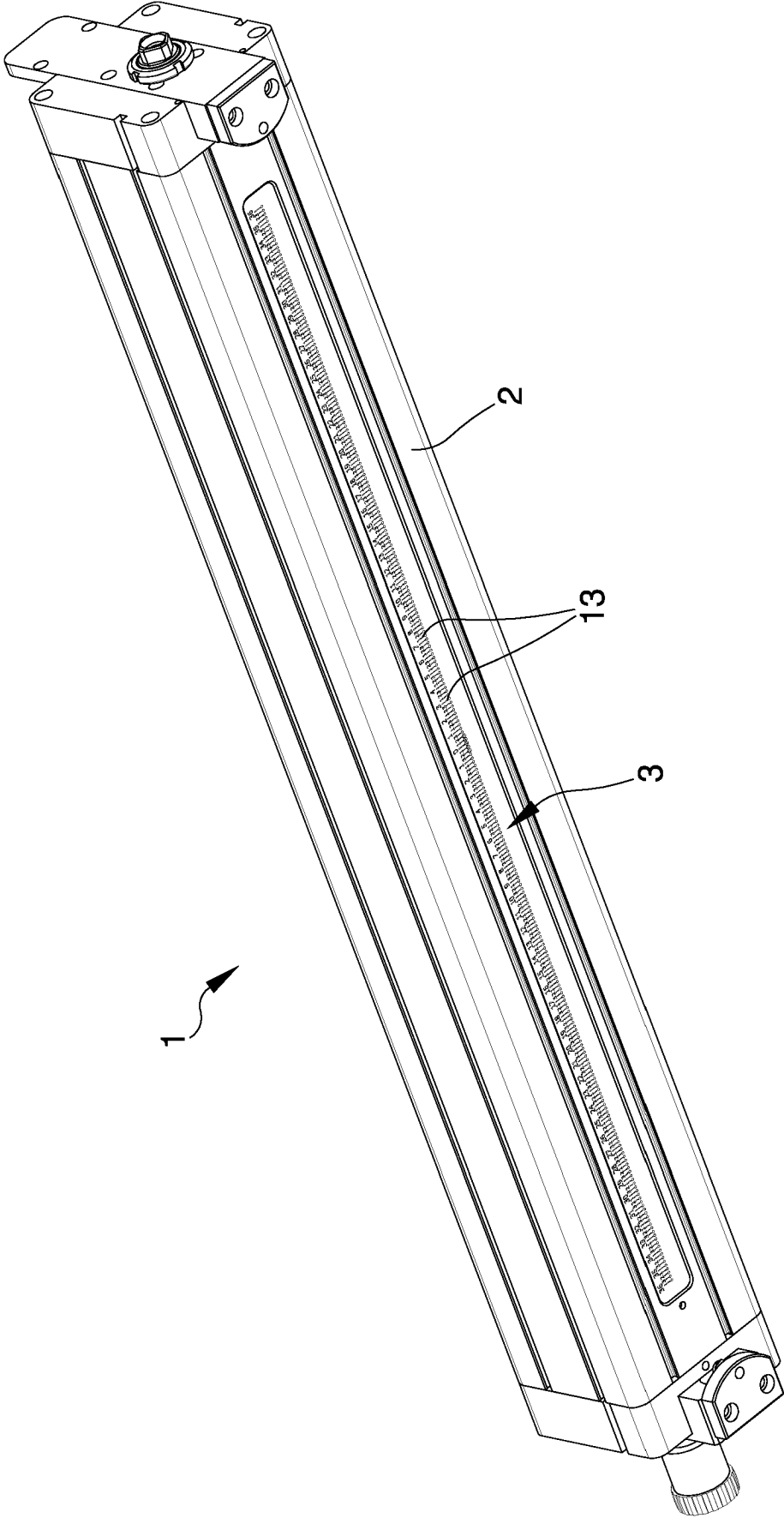

Fig.1

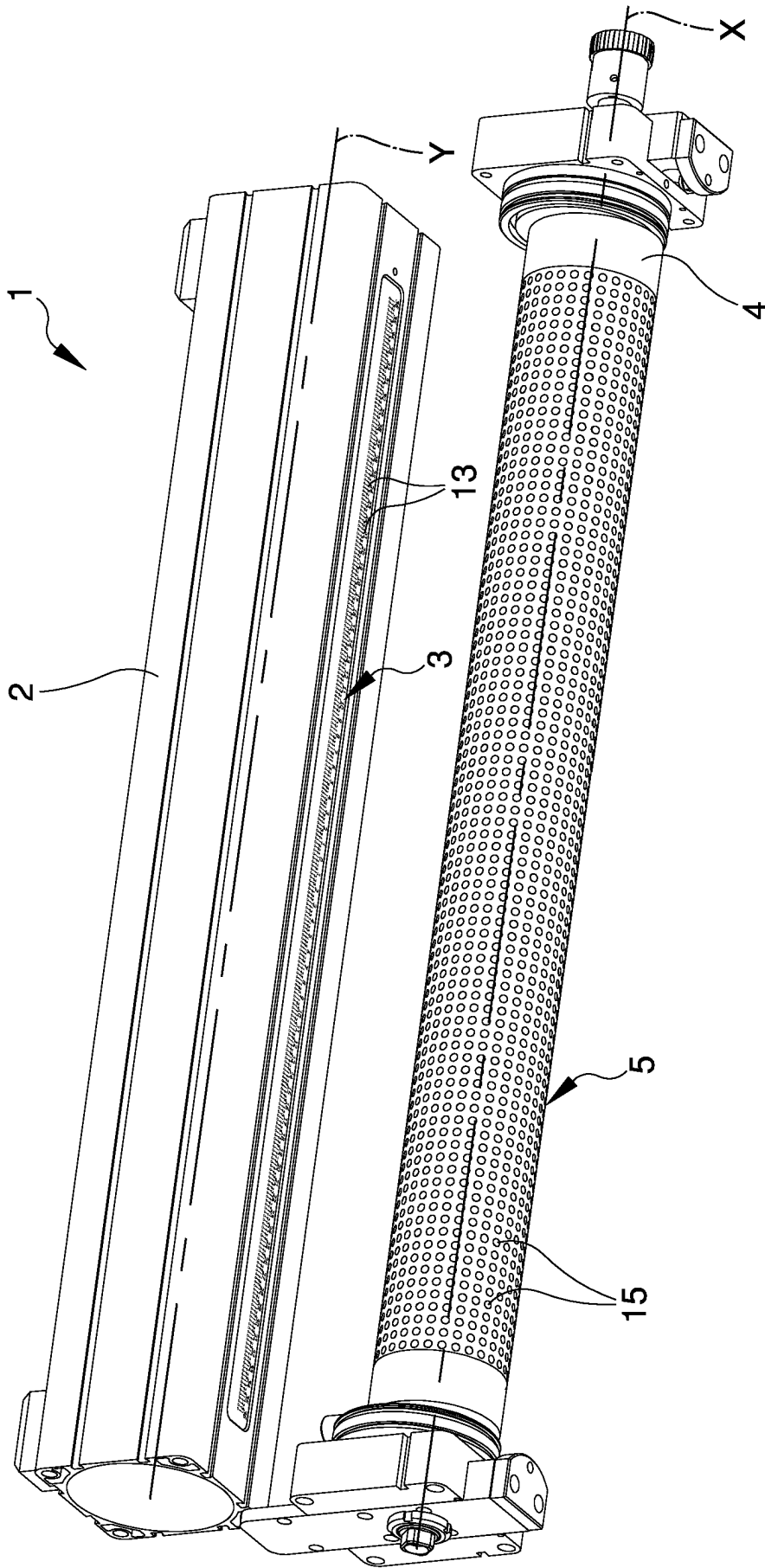

Fig.2

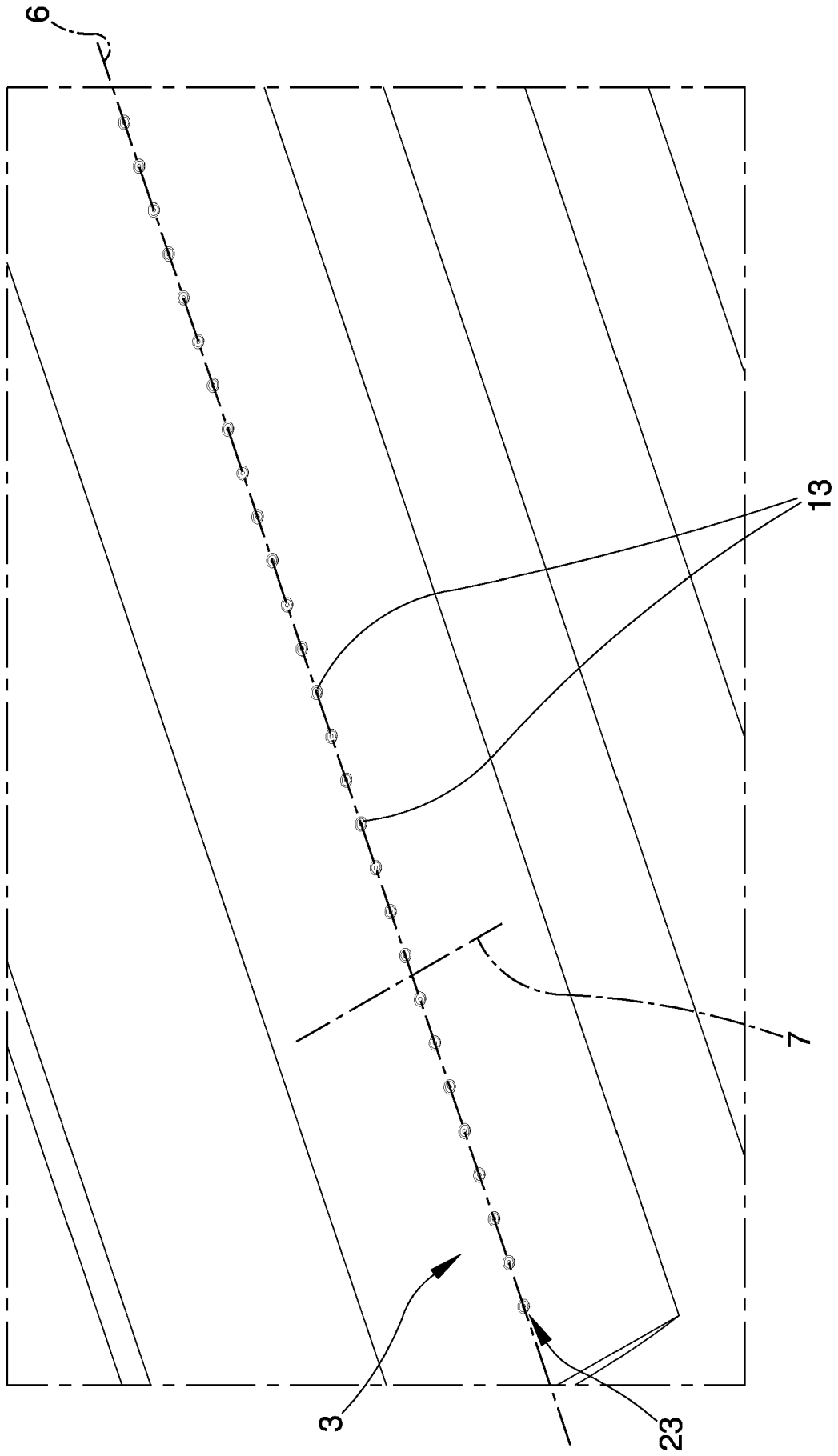

Fig.3

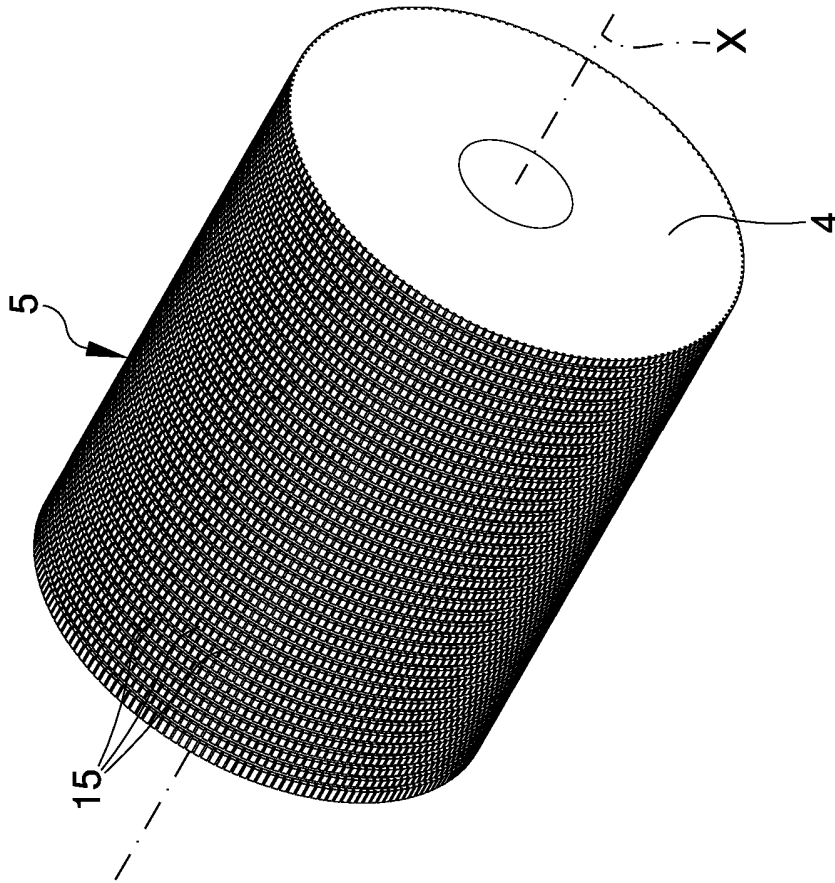

Fig.4

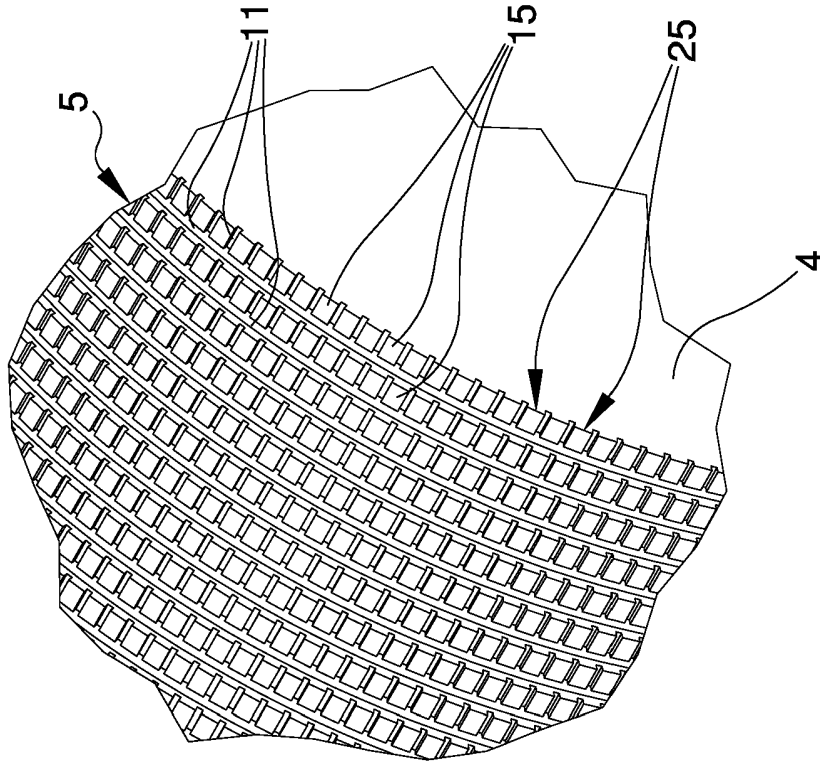

Fig.5

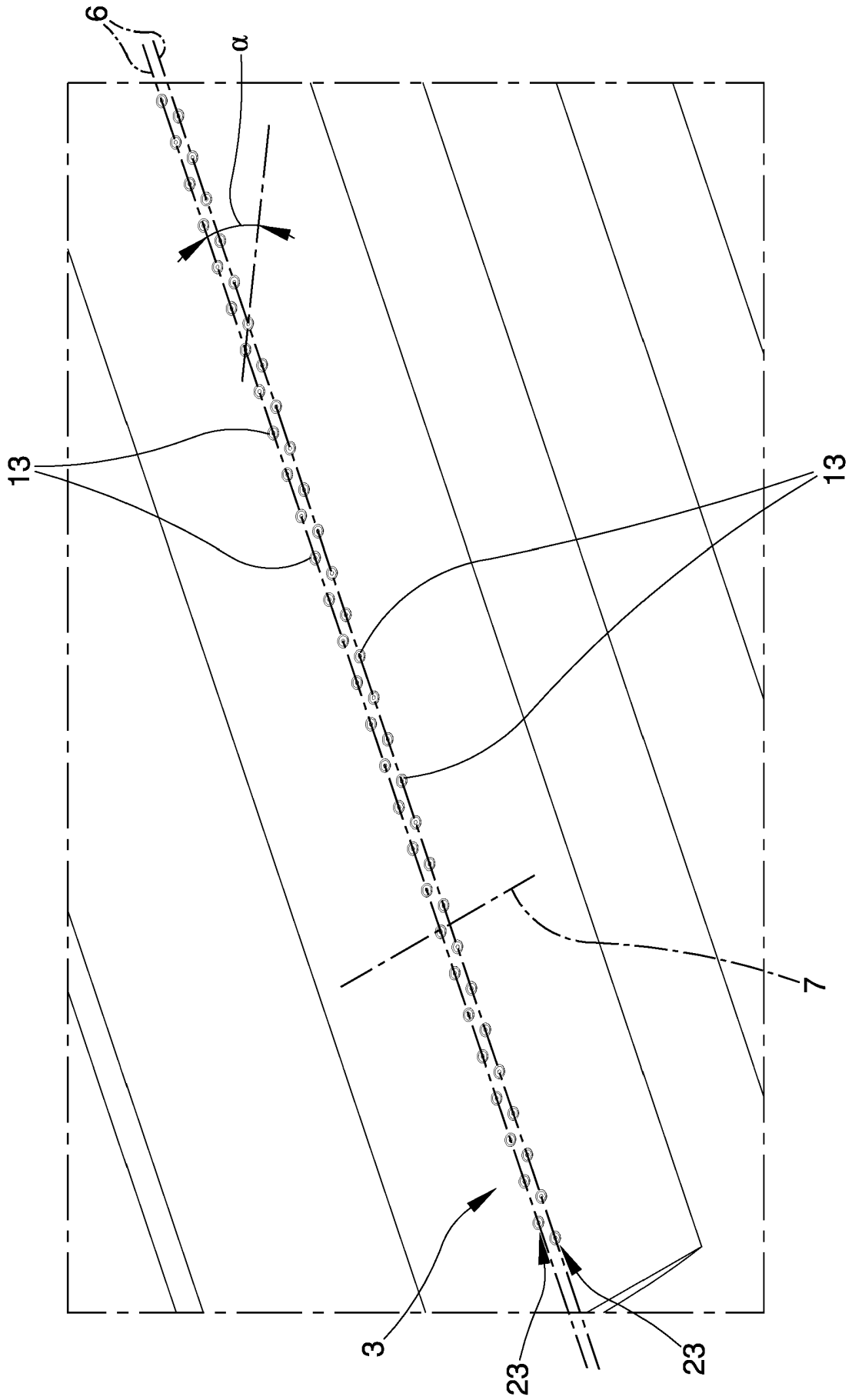

Fig.6

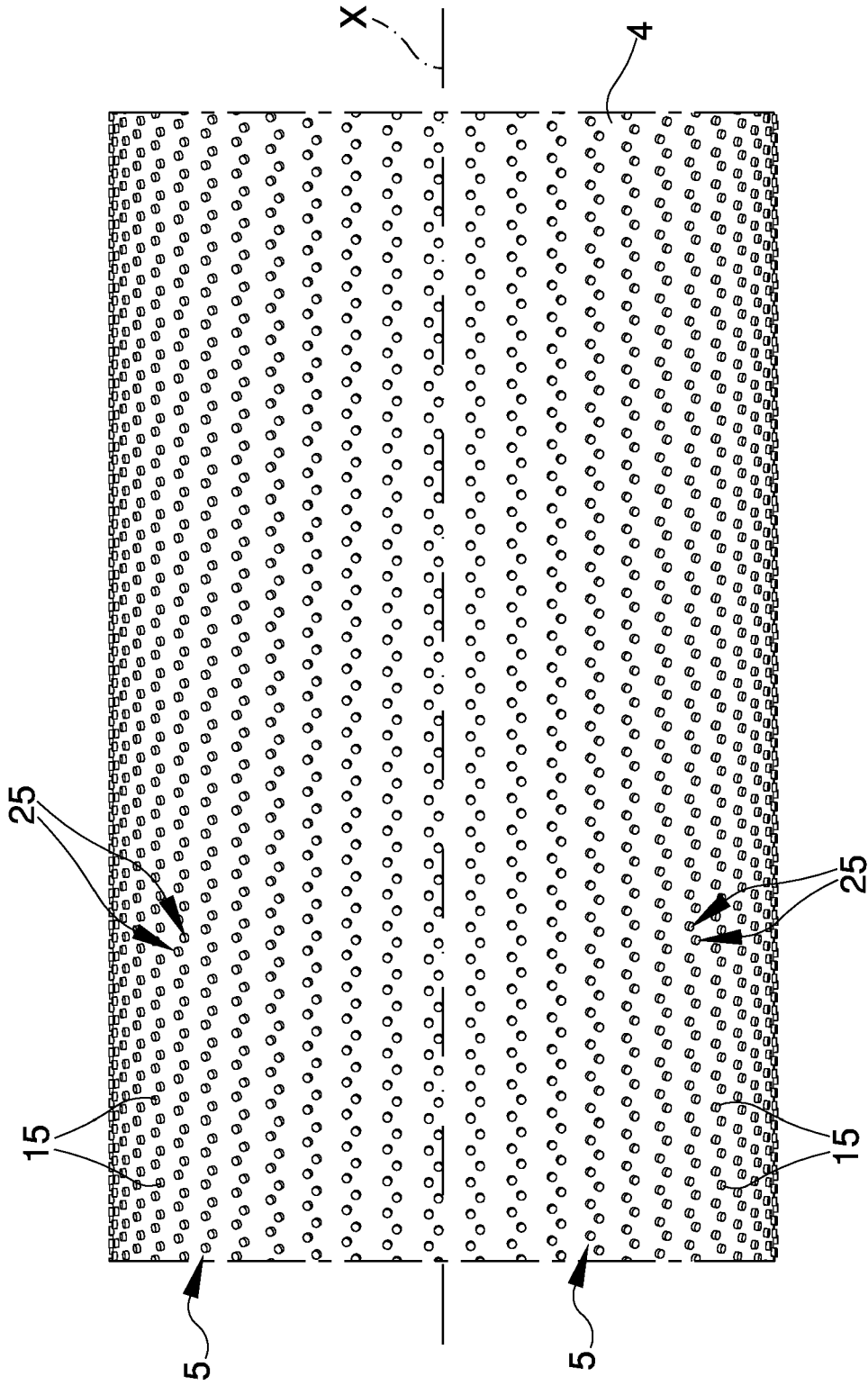

Fig.7

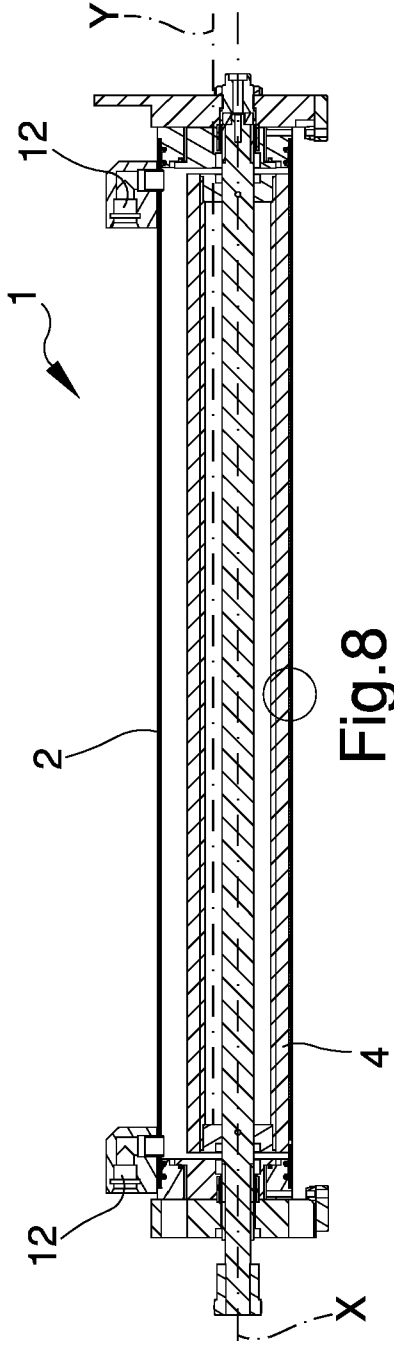

Fig. 8

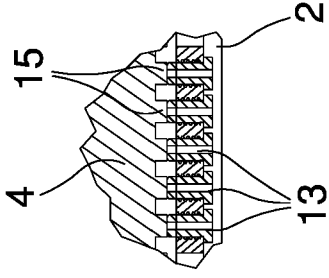

Fig. 9

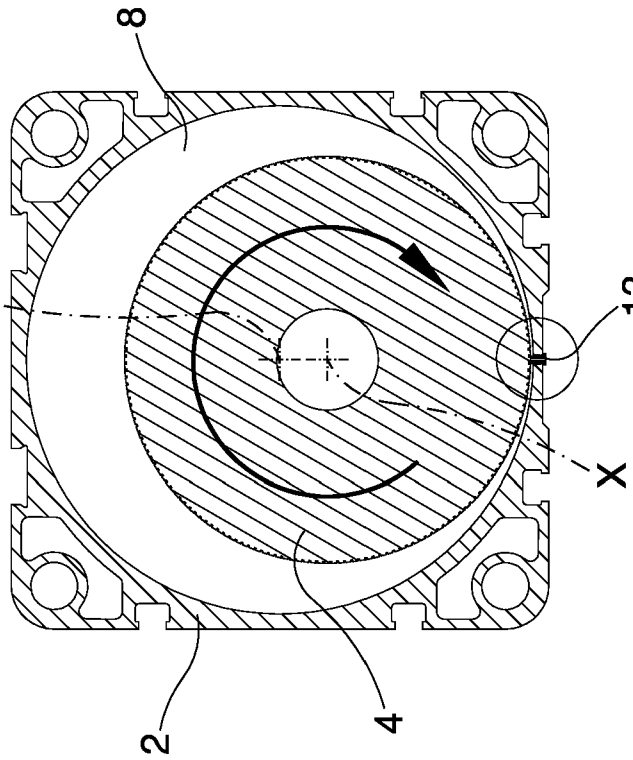

Fig. 10

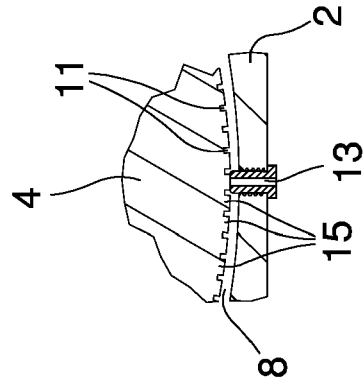

Fig. 11

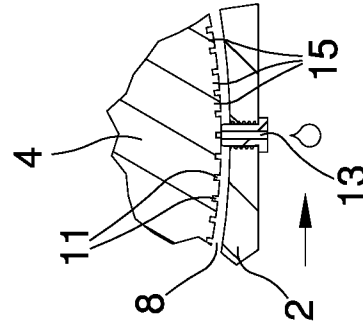

Fig. 12

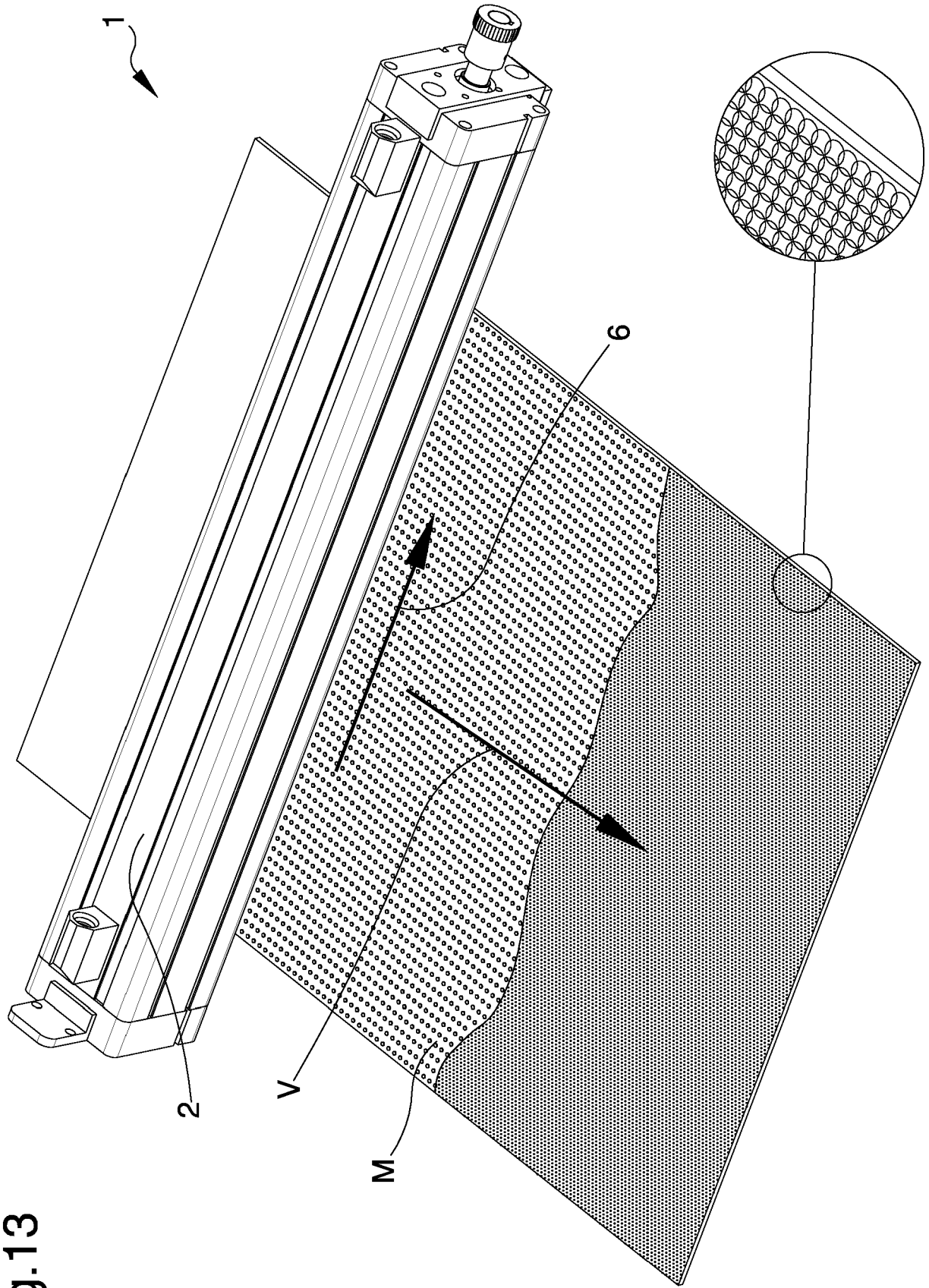

Fig.13

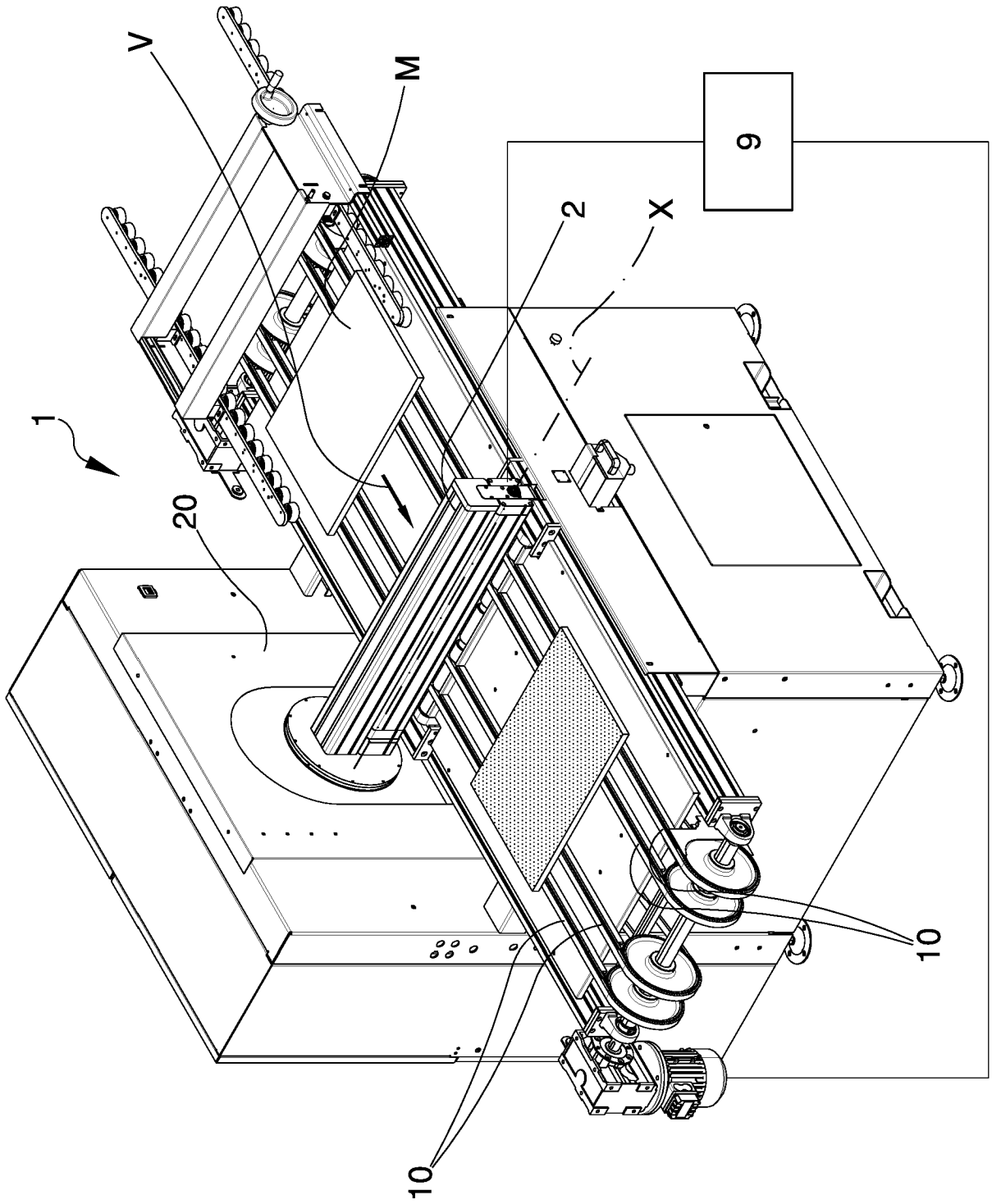

Fig.14

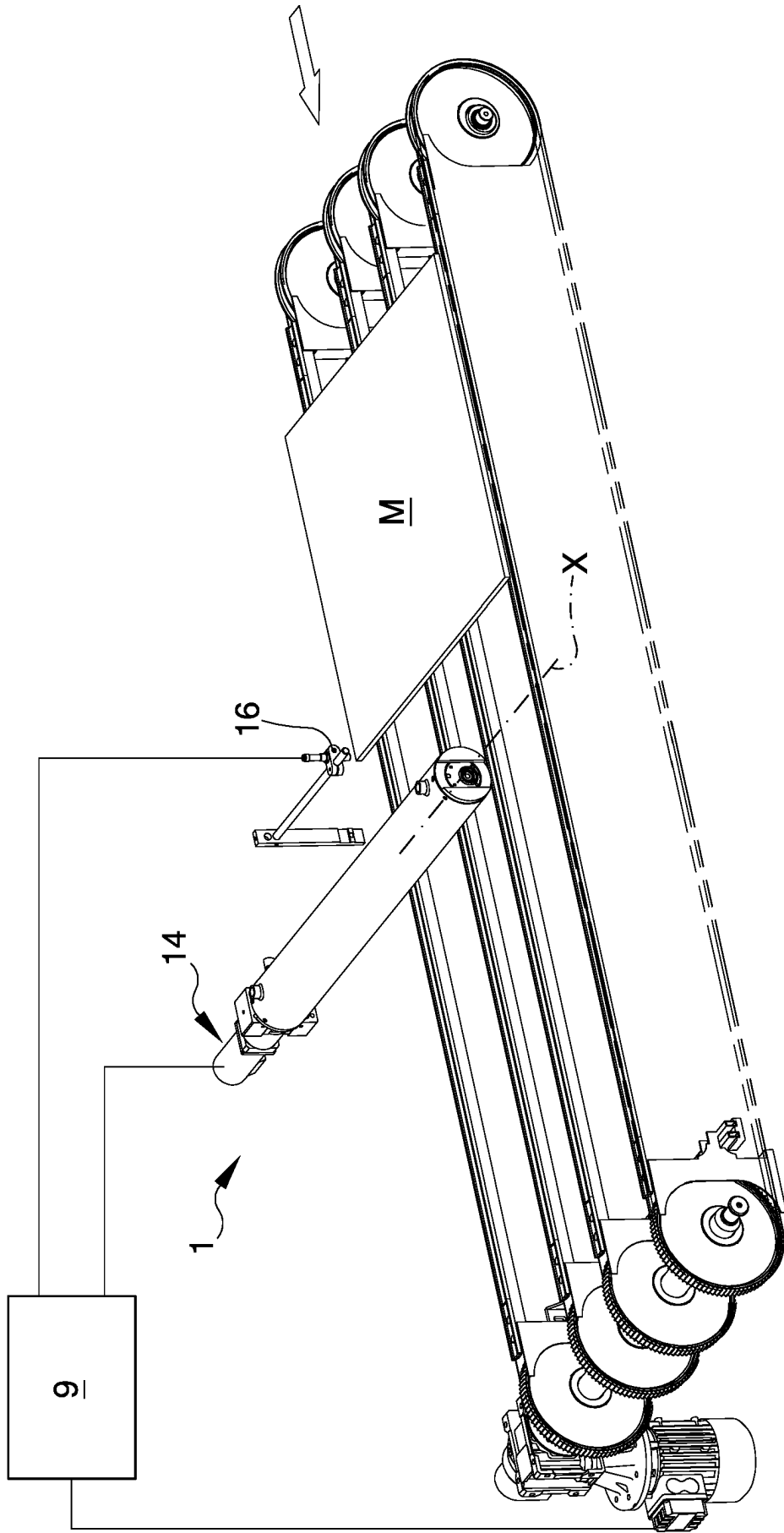

Fig.15

REFERENCES CITED IN THE DESCRIPTION

This list of references cited by the applicant is for the reader's convenience only. It does not form part of the European patent document. Even though great care has been taken in compiling the references, errors or omissions cannot be excluded and the EPO disclaims all liability in this regard.

Patent documents cited in the description

- US 2003230647 A [0015] [0016]
- DE 4416747 [0015] [0019] [0020]
- US 200323064 B [0017] [0018]
- WO 2017209926 A1 [0021]