

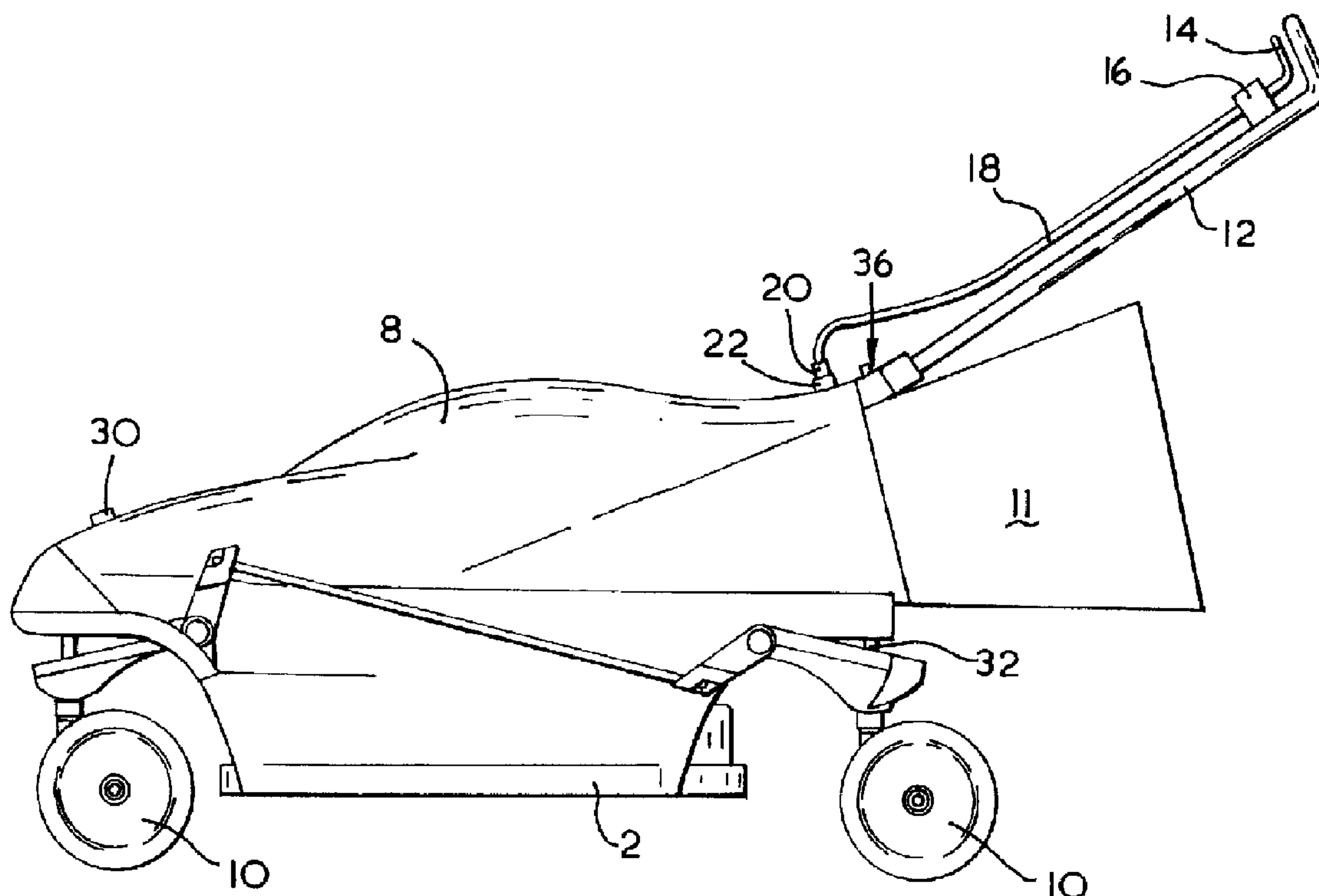

(22) Date de dépôt/Filing Date: 1999/06/14
 (41) Mise à la disp. pub./Open to Public Insp.: 1999/12/16
 (45) Date de délivrance/Issue Date: 2004/08/24
 (30) Priorité/Priority: 1998/06/16 (9812933.5) GB

(51) Cl.Int.⁶/Int.Cl.⁶ A01D 34/82, A01G 3/00
 (72) Inventeur/Inventor:
 THOMAS, ROGER, GB
 (73) Propriétaire/Owner:
 BLACK & DECKER INC., US
 (74) Agent: SIM & MCBURNEY

(54) Titre : SYSTEME D'OUTILS
 (54) Title: TOOL SYSTEM



(57) Abrégé/Abstract:

A garden power tool system comprising a lawn mower powered by a battery mounted on the mower and a plurality of gardening implements such as a hedge trimmer and a string trimmer (38; 53) which are electrically powered and are capable of being connected to the mower wherein the battery (6) provides the electrical power for the garden implements (38; 53) when they are connected to the mower. The mower can be mounted on castor wheels (10). Ideally, the garden implements (38; 53) are releasably attachable via a connecting mechanism (48, 30) and an electric cable (46; 66) to the mower, the connecting mechanism (48, 30) providing electrical connection between the battery (6) and garden implement (38; 53) when attached and is sufficiently robust to enable the mower to be dragged around by the garden implement (38; 53) when connected.

ABSTRACT

5 A garden power tool system comprising a lawn mower powered by a battery mounted on the mower and a plurality of gardening implements such as a hedge trimmer and a string trimmer (38; 53) which are electrically powered and are capable of being connected to the mower wherein the battery (6) provides the electrical power for the garden implements (38; 53) when they are connected to the mower. The mower can be mounted on castor wheels (10).

10 Ideally, the garden implements (38; 53) are releasably attachable via a connecting mechanism (48, 30) and an electric cable (46; 66) to the mower, the connecting mechanism (48, 30) providing electrical connection between the battery (6) and garden implement (38; 53) when attached and is sufficiently robust to enable the mower to be dragged around by the garden implement (38; 53) when connected.

15

TOOL SYSTEM

The present invention relates to garden implements and in particular to
5 electrically powered garden implements.

Most household gardens comprise a number of different features such as trees,
lawns, flower beds, bushes, rockeries, paths and patios. Therefore, a gardener requires
a range of garden implements in order to assist him in the maintenance of the garden.
10 The majority of these implements are powered, usually by an electrical motor. Such
implements include hedge trimmers, blow vacs, string trimmers, chain saws, lawn
mowers, reciprocating saws and edgers.

Electrically powered garden implements are either powered by a mains
15 electricity supply or a battery.

Garden implements powered by a mains electricity supply have to be
connected via a cable to the supply. This restricts the locations where the garden
implements can be used to areas within reach of a power supply outlet which is
20 determined by location of the power supply outlet and by the length of the cable.
Cable extensions can be added. However, this incurs additional costs.

Garden implements powered by a battery are not so restricted as to the
locations where they can be used compared with mains powered tools. However, each
25 tool requires a separate battery and separate charging system incurring the cost of a
battery and charger for each tool. Furthermore, the battery is attached directly to the
tool. This adds an additional burden to the user because, in addition to supporting the
power tool itself, he has to support the battery. Large batteries used in such power
tools can be heavy requiring the user to make a considerable exertion in order to
30 support both the power tool and the battery.

The run of time of a power tool between the recharges of the battery is
dependent on the size of the battery. However, the size of the battery has to be limited
so that the user is able to both support and manoeuvre the power tool. Therefore, the
35 run time between recharges is limited.

The object of the present invention is to overcome the above problems.

According to the first aspect of the present invention, there is provided a garden power tool system comprising a lawn mower and a plurality of gardening implements wherein the mower is powered by a battery mounted on the mower and
5 the garden implements are electrically powered and are capable of being connected to the mower via a connecting mechanism which is sufficiently robust to enable the mower to be dragged around by the garden implement when connected, the battery providing the electrical power for the garden implements when they are connected to the mower, and wherein the mower is mounted on castor wheels.

10

By powering the garden implements from the battery of the mower, there is no need for the garden implement to be used near to an electrical power outlet. The mower can be easily wheeled to the required location so that the garden implement can be used wherever desired.

15

Because the battery is mounted on the lawn mower, which in turn is supported via wheels on the ground, the user does not have to support or manoeuvre the battery when using the gardening implement. Furthermore, as the weight of the battery is supported by the mower, it can be considerably larger than if it were supported by the
20 user. Therefore, a far larger battery can be used, greatly increasing the run time of the gardening implement between recharges.

Furthermore, the mower can be used to support the weight of part of a connected garden implement, thus lightening the load which a user has to bear when
25 using the garden implement.

The lawn mower can be made to be highly manoeuvrable over the surface of the ground by mounting it on castor wheels to allow it to travel in any direction both linear and rotational. Because the garden implements are connected to such a mower,
30 the tool system can easily be moved around in any direction either with any garden implement connected to it, or by the garden implement itself.

Having a connecting mechanism which is sufficiently robust allows the mower to be manoeuvred around by the garden implement without the garden implement
35 becoming detached.

Preferably, the garden implements are releasably attachable via a connecting mechanism to the mower, the connecting mechanism, providing electrical connection between the battery and garden implement when attached.

5 This allows the garden implements to be detached from the mower when not required.

Certain garden implements can be attached directly to the mower for example a shredder. However, for other garden implements such as hand held implements it is
10 advantageous that the garden implement is attached to the mower via an electric cable. This allows the garden implement to be used remotely from the mower. This is a particularly useful feature, as the garden implement can be used in places not easily accessible to the mower such as up a tree. Furthermore, the mower may be easily dragged around by the garden implement via the cable.

15

The electric cable may be flexible in length. Such cables can include cable coiled in a helical spring which is able to stretch when a force is applied to the cable. The use of such a cable enables any excess length of cable between the mower and garden implement to be kept tidy and as such, it is less of a safety hazard.

20

The mower can comprise a handle which is releasably attachable to the mower. Alternatively or additionally, the mower can comprise a handle which is capable of being folded down onto the body of the mower. When the mower is being dragged around by a garden implement, the handle of the mower may get caught in
25 bushes or ornaments. Therefore, when it is not being used to manoeuvre the mower, it is desirable to either remove it or fold it away. Many types of mower comprise a grass box for catching the grass cuttings. However, as the mower itself is not being used whilst a garden implement is being used, it is also preferable that the grass box is releasably attachable so that it can be removed to minimise the size of the mower.

30

Examples of such garden implements are a hedge trimmer, a shredder, a string trimmer, a chain saw, a shrubber, a weeder, a pruner and any other hand held electrically powered garden implement.

According to the second aspect of the present invention, there is provided a lawn mower for use in a garden power tool system wherein the lawn mower is powered by a battery mounted on the mower and comprises a connecting mechanism in electrical connection with the battery which is capable of being connected to by one
5 or more garden implements to enable the battery to power the garden implements when they are connected to the connector and which is sufficiently robust to enable the mower to be dragged around by the connecting mechanism, and wherein the mower is mounted on castor wheels.

10 The mower can comprise a handle and/or a grass box which is releasably attachable to the mower.

An embodiment of the present invention will now be described with reference to the accompanying drawing of which:-

15

Figure 1 shows a side view of the lawn mower according to the first embodiment of the present invention;

Figure 2 shows the electrical circuit of the lawn mower;

Figure 3 shows the hedge trimmer garden implement;

20 Figure 4 shows the string trimmer garden implement; and

Figure 5 shows a side view of the lawn mower according to the third embodiment of the present invention.

25 The garden power tool system comprises a lawn mower and a plurality of electrically power garden implements which can be connected to the lawn mower.

The first embodiment of the present invention will now be described. Referring to Figure 1 and 2, the lawn mower comprises a cutting deck (2) upon which is mounted a motor (4) and a battery (6). A hood (8) encloses the motor (4) and
30 battery (6). The cutting deck (2) is mounted on four castor wheels (10) located near to the four corners of the cutting deck (2). The motor (4) rotatably drives a cutting blade (not shown) mounted below the cutting deck (2) on the output drive spindle of the motor (4) about a substantially vertical axis. A grass box (11) is attached to the rear of the deck (2). A detachable handle (12) is attached to the rear of the deck (2).
35 Located on the handle (12) is a lever (14) which projects from a lever box (16) attached to the handle (12) and which encloses an electric switch (17). Two electric cables (18) run from the lever box (16) to a plug (20). A corresponding socket (22) is

mounted on the rear of the cutting deck (2). A cable (24) runs under the hood (8) from the socket (22) to a terminal of the battery (6). Figure 2 shows the internal wiring diagram of the mower. A second cable (26) runs from the socket (22) to a terminal of the motor (4). A third electric cable (28) runs between the battery (6) and the motor (4). An electric circuit is formed between the motor (4) and the battery (6) via the electric switch (17) when the plug (20) is connected to the socket (22). The electric circuit is completed by the activation of the electric switch (17) by depression of the lever (14), thus energising the electric motor (4).

10 A second socket (30) is mounted on the front of the cutting deck (2). Two electric cables (32, 34) run from the terminals of the battery (6) to the second electric socket (30). The socket comprises a bayonet connector.

15 The handle (12) is detachably connected to the rear of the deck by a clip mechanism (36). When the clip mechanism (36) is released, the handle (12) is detached from the body of the mower. The electric cables (18) which run from the lever box (26) on the handle (12) to the body of the mower is released by unplugging the first plug (20) from the socket (22) mounted on the rear of the cutting deck (2).

20 The disconnection of the first plug (20) and socket (22) does not interfere in any way between the electrical connection between the battery (6) and the second socket (30) on the side of the cutting deck.

25 Figure 3 shows a hedge trimmer garden implement (38) which is attachable to the lawn mower. The hedge trimmer (38) comprises a rear handle (40) which is attached to the rear of the body (42) of the hedge trimmer (38). An electric motor (not shown) is located within the body (42). The motor reciprocatingly drives the hedge trimmer blades (44) attached to the front of the hedge trimmer (38) in a known manner. A helical stretchable electric cable (46) extends from the rear of the rear handle (40) to an electric plug (48) having a bayonet connection which is capable of mating with the second socket (30) on the lawn mower. The electric cable (46) passes through the rear handle (40) via a trigger switch (50) mounted on the rear handle (40) to the electric motor. A front bail handle (52) is mounted on the front of the body (42) of the hedge trimmer (46).

35

Figure 4 shows a string trimmer (53) comprising an elongate rod (54) having a motor housing (56) formed at one end and a rear handle (58) formed at the other. An

electric motor (not shown) is mounted within the motor housing (56) which rotatingly drives a cutting head (60) in a known manner. A cutting line (62) extends from the cutting head (60). An electric cable (66) extends from the rear handle (58) to an electric plug (68) having a bayonet connection which is capable of mating with the
5 second socket (30) on the lawn mower. The cable (66) passes through the rear handle (58) via a trigger switch (70) mounted on the rear handle (58), through the elongate rod (54) to the motor.

In use, a gardener would mow the lawn using the lawn mower in the known
10 fashion. The gardener then may wish to trim the hedges. The gardener would connect the plug (48) of the hedge trimmer garden implement (38) into the second socket (30) located on the side of the cutting deck (2) of the mower. When the hedge trimmer garden implement (38) is connected to the socket (30) an electrical circuit is formed between the electric motor of the hedge trimmer (38) and the battery (6) of the mower
15 via the trigger switch (50) on the hedge trimmer (38). Depression of the trigger switch (50) activates the motor and thus starts the hedge trimmer.

The gardener would commence trimming the hedges. As the gardener moves around the garden with the hedge trimmer garden implement (38), the mower would
20 be pulled behind by the gardener via the electric cable (46). The plug (48) and socket (30) connection is robust enough to withstand the pulling forces exerted onto the cable (46). Because the mower is mounted on castor wheels (10), it is able to follow the gardener with hedge trimmer attachment (38) in any direction and can easily change direction when required.

25 The handle (12) of the mower may become entangled in the hedges as it is pulled along by the gardener. Therefore, the handle (12) can be detached by unclipping the handle (12) from the cutting deck (2) and disconnecting the first plug (20) from the socket (22) at the rear of the deck (2). In this fashion, only the body of
30 the mower is pulled along behind the gardener.

In order to change implements, the plug (48) of the hedge trimmer attachment (38) is removed from the second socket (30), and the plug (68) of the string trimmer attachment (53) is connected to the second socket (30). The string trimmer
35 attachment is then used in the normal manner, the mower being pulled along behind the trimmer via the cable (66).

In the second embodiment of the present invention, the hedge trimmer attachment (38) and string trimmer attachment (53) is permanently connected via a cable directly to the battery (6), thus avoiding the need for a plug (48; 68) and the second socket (30). When not being used, the attachments (38; 53) are stored in specifically formed recesses integrally moulded into the hood (8) of the mower.

The third embodiment of the present invention is the same as the first embodiment except that the grass box (11) is detachable and that the handle (12) is capable of being folded onto the body of the mower.

10

Figure 5 shows the lawn mower according to the third embodiment in which the grass box (11) has been removed and the handle folded up.

15

20

25

30

35

CLAIMS

1. A garden power tool system comprising a lawn mower and a plurality of gardening implements wherein the mower is powered by a battery mounted on the mower and the garden implements are electrically powered and are capable of being connected to the mower via a connecting mechanism which is sufficiently robust to enable the mower to be dragged around by the garden implement when connected, the battery providing the electrical power for the garden implements when they are connected to the mower, and wherein the mower is mounted on castor wheels.
5
- 10 2. A tool system as claimed in claim 1 wherein the garden implements are releasably attachable via the connecting mechanism to the mower, the connecting mechanism providing electrical connection between the battery and garden implement when attached.
- 15 3. A tool system as claimed in either of claims 1-2 wherein the garden implement is attached to the mower via an electric cable.
- 20 4. A tool system as claimed in claim 3 wherein the electric cable is flexible in length.
5. A tool system as claimed in any one of claims 1-4 wherein the mower comprises a handle which is releasably attachable to the mower.
- 25 6. A tool system as claimed in any one of claims 1-5 wherein the mower comprises a handle which is capable of being folded down onto the body of the mower.
- 30 7. A tool system as claimed in any one of claims 1-6 wherein the mower comprises a grass box which is releasably attachable to the mower.
8. A tool system as claimed in any one of claims 1-7 wherein the garden implement can be any one of a hedge trimmer, a string trimmer, a chain saw, a shrubber, a weeder or a pruner.

9. A lawn mower for use in a garden power tool system wherein the lawn mower is powered by a battery mounted on the mower and comprises a connecting mechanism in electrical connection with the battery which is capable of being
5 connected to by one or more garden implements to enable the battery to power the garden implements when they are connected to the connector and which is sufficiently robust to enable the mower to be dragged around by the connecting mechanism, and wherein the mower is mounted on castor wheels.
- 10 10. A lawn mower as claimed in claim 9 wherein the mower comprises a handle which is releasably attachable to the mower.
11. A lawn mower as claimed in either of claims 9 or 10 wherein the mower comprises a grass box which is capable of being releasably attached to the mower.
15
12. A lawn mower as claimed in any one of claims 9 to 11 wherein the mower comprises a handle which is capable of being folded down onto the body of the mower.

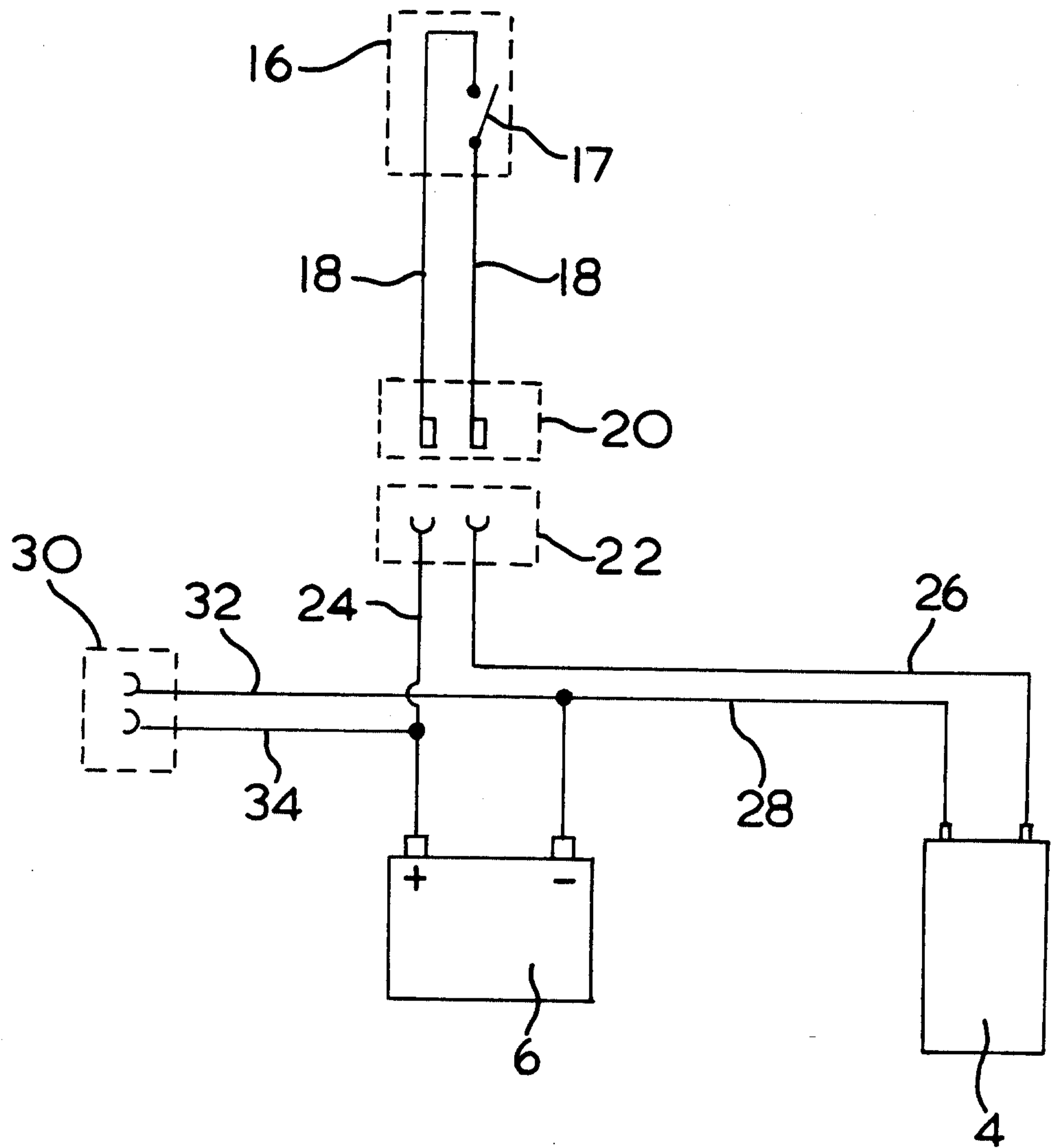

FIG. 2

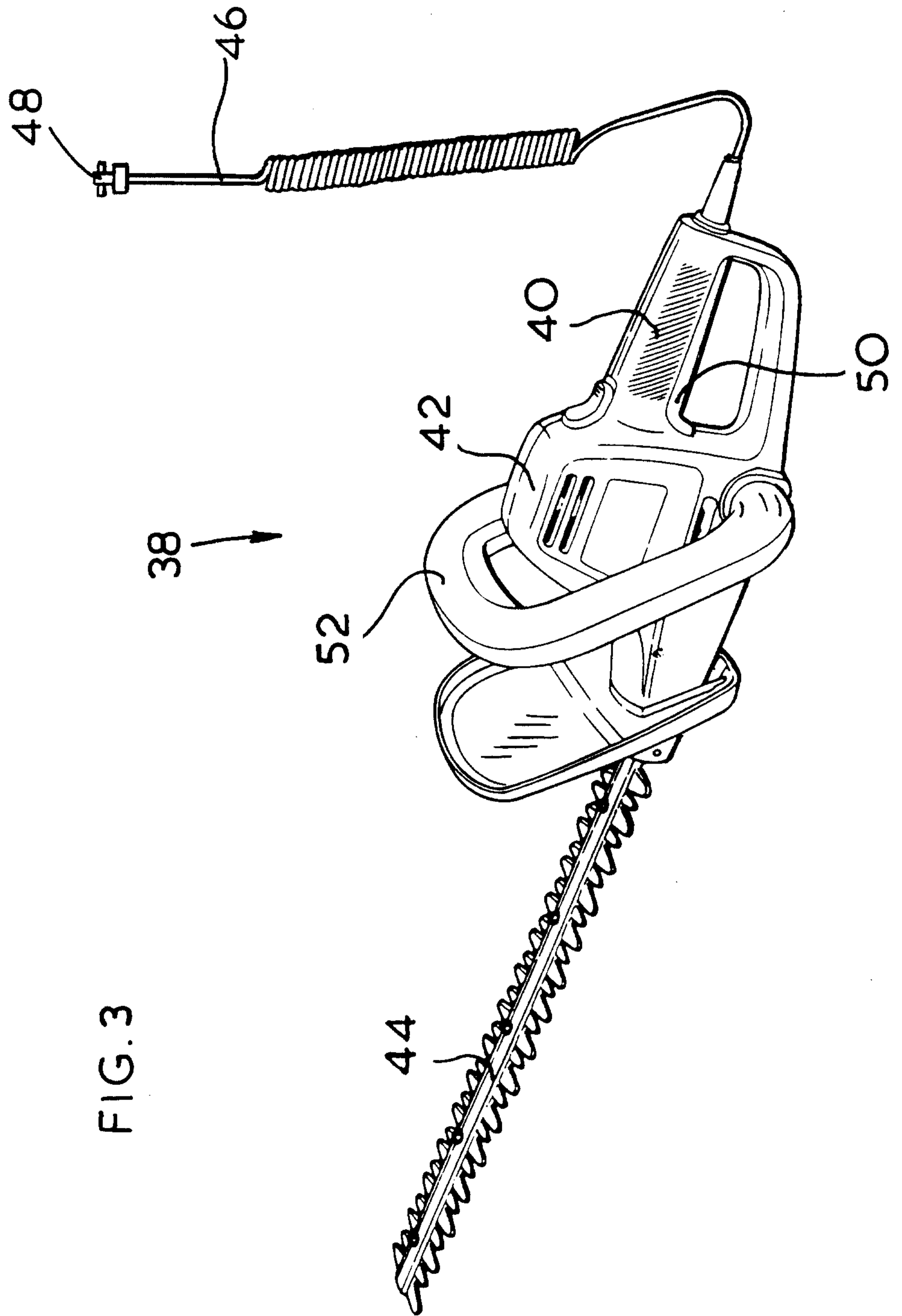

FIG. 3

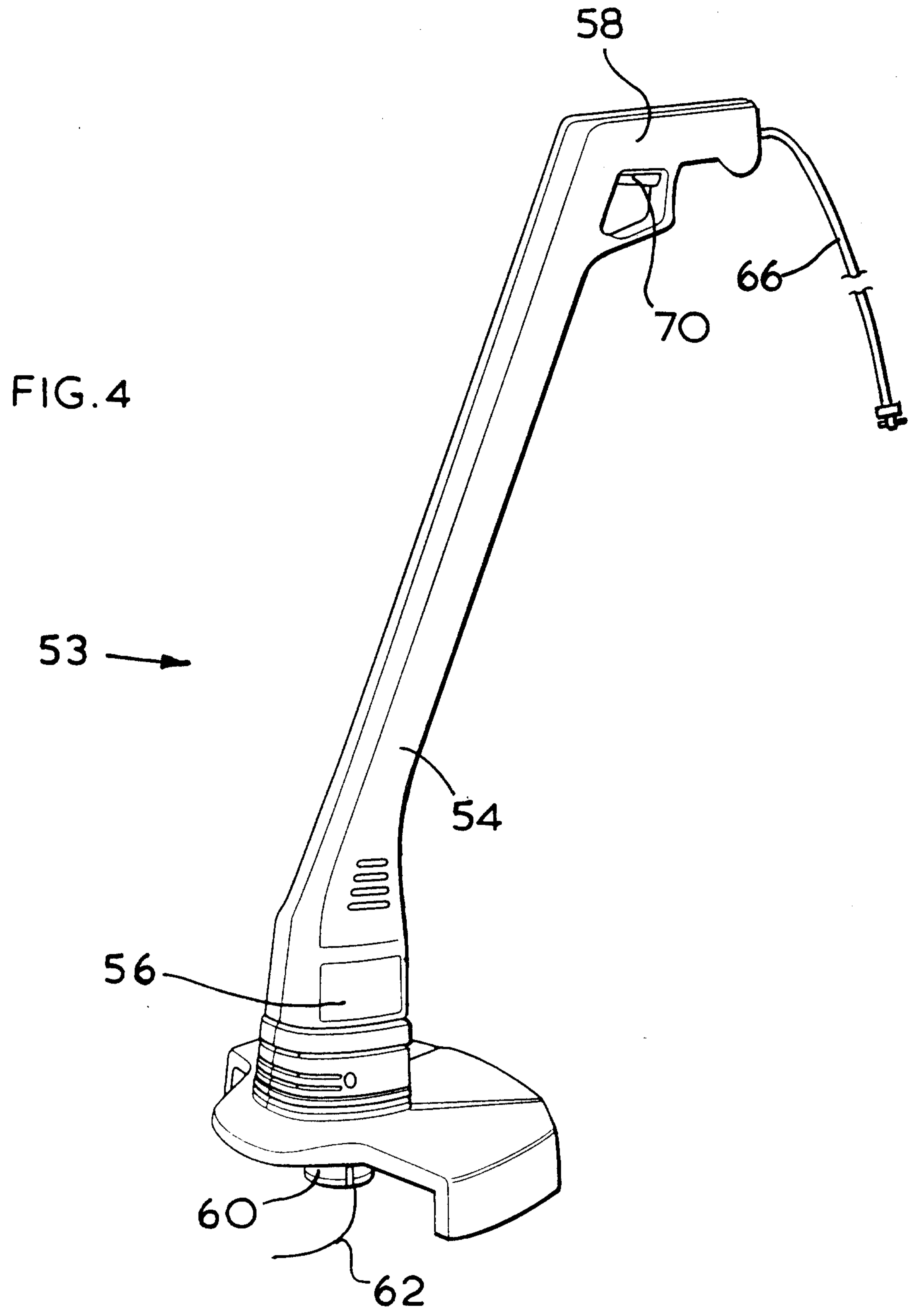

FIG. 5

