

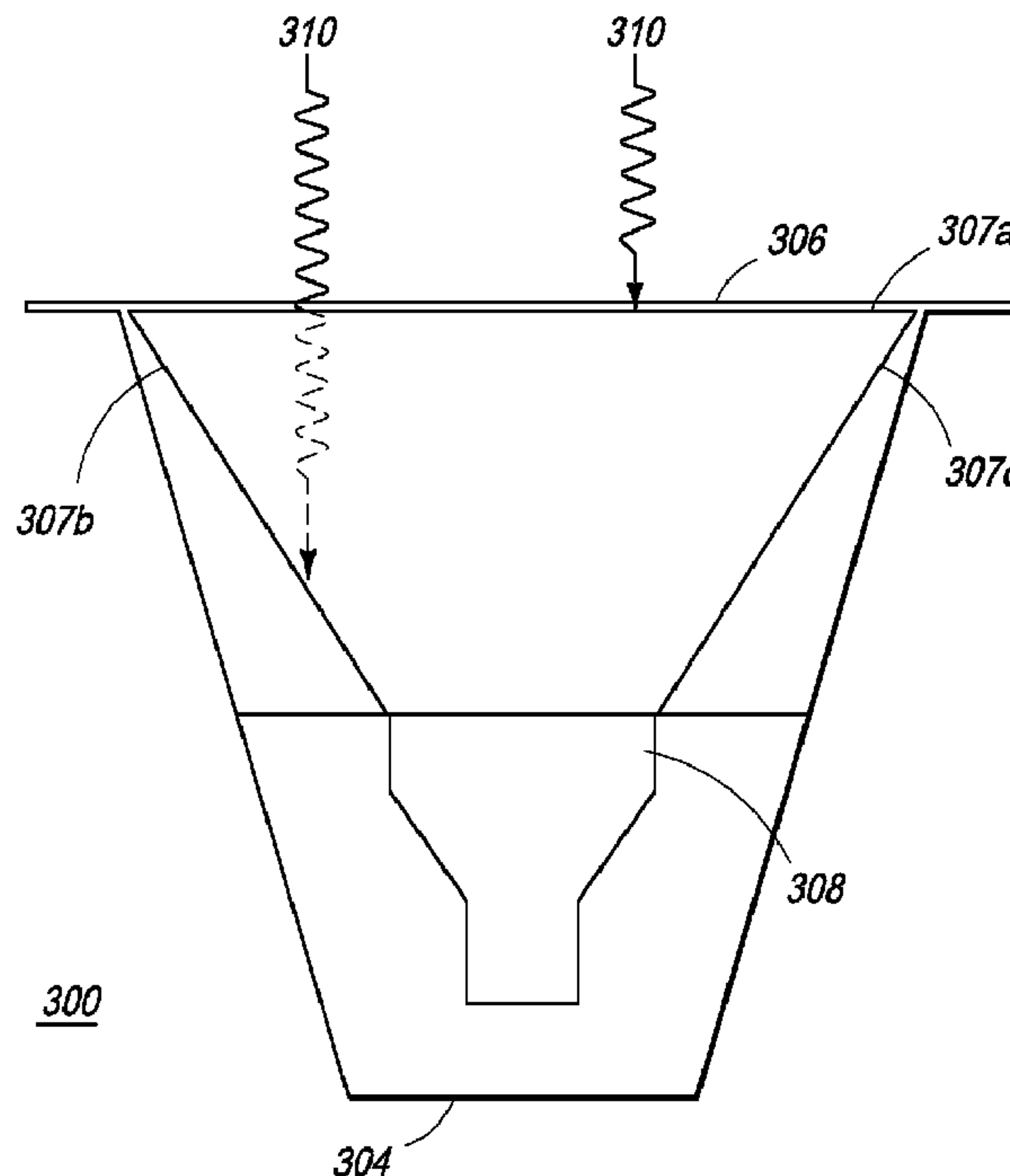

(86) **Date de dépôt PCT/PCT Filing Date:** 2008/10/31
 (87) **Date publication PCT/PCT Publication Date:** 2009/05/07
 (45) **Date de délivrance/Issue Date:** 2017/01/24
 (85) **Entrée phase nationale/National Entry:** 2011/04/28
 (86) **N° demande PCT/PCT Application No.:** US 2008/081988
 (87) **N° publication PCT/PCT Publication No.:** 2009/059131
 (30) **Priorité/Priority:** 2007/11/01 (US60/984,640)

(51) **Cl.Int./Int.Cl. G01T 1/28** (2006.01),
G01N 23/00 (2006.01), **G01N 23/203** (2006.01),
G01T 1/20 (2006.01)
 (72) **Inventeurs/Inventors:**
 RYGE, PETER, US;
 HUGHES, RONALD J., US;
 GRAY, STEVEN J., US
 (73) **Propriétaire/Owner:**
 RAPISCAN SYSTEMS, INC., US
 (74) **Agent:** NORTON ROSE FULBRIGHT CANADA
 LLP/S.E.N.C.R.L., S.R.L.

(54) **Titre : SYSTEMES DE DETECTION MULTI-ECRANS**
 (54) **Title: MULTIPLE SCREEN DETECTION SYSTEMS**



(57) **Abrégé/Abstract:**

The present invention is a detection system and method for using the detection system in radiant energy imaging systems. In particular, the present invention is an improved detection system employing multiple screens for greater detection efficiency. And

(57) Abrégé(suite)/Abstract(continued):

more particularly, the present invention is a detection system for detecting electromagnetic radiation having an enclosure having four adjacent walls, connected to each other at an angle and forming a rectangle and interior portion of the enclosure, a front side area and a back side area formed from the four adjacent walls and located at each end of the enclosure, at least two screens, that further include an active area for receiving and converting electromagnetic radiation into light, and a photodetector, positioned in the interior portion of the enclosure, having an active area responsive to the light.

(12) INTERNATIONAL APPLICATION PUBLISHED UNDER THE PATENT COOPERATION TREATY (PCT)

(19) World Intellectual Property Organization
International Bureau



(43) International Publication Date
7 May 2009 (07.05.2009)

PCT

(10) International Publication Number
WO 2009/059131 A1

(51) International Patent Classification:
H01J 40/14 (2006.01)

(21) International Application Number:

PCT/US2008/081988

(22) International Filing Date: 31 October 2008 (31.10.2008)

(25) Filing Language:

English

(26) Publication Language:

English

(30) Priority Data:

60/984,640 1 November 2007 (01.11.2007) US

(71) Applicant (for all designated States except US): **RAPIS-CAN SECURITY PRODUCTS, INC.** [US/US]; 2805 Columbia Street, Torrance, CA 90503 (US).

(72) Inventors; and

(75) Inventors/Applicants (for US only): **RYGE, Peter** [US/US]; 6427 Cayenne Lane, Carlsbad, CA 92009 (US). **HUGHES, Ronald, J.** [US/US]; 12812 Topaz Street, Garden Grove, CA 92845 (US). **GRAY, Steven, J.** [US/US]; 2470 Stoneway Court NW, Salem, OR 92304 (US).

(74) Agent: **HAZIM, Ansari**; Patentmetrix, 14252 Culver DR., Box 914, Irvine, CA 92064 (US).

(81) Designated States (unless otherwise indicated, for every kind of national protection available): AE, AG, AL, AM, AO, AT, AU, AZ, BA, BB, BG, BH, BR, BW, BY, BZ, CA, CH, CN, CO, CR, CU, CZ, DE, DK, DM, DO, DZ, EC, EE, EG, ES, FI, GB, GD, GE, GH, GM, GT, HN, HR, HU, ID, IL, IN, IS, JP, KE, KG, KM, KN, KP, KR, KZ, LA, LC, LK, LR, LS, LT, LU, LY, MA, MD, ME, MG, MK, MN, MW, MX, MY, MZ, NA, NG, NI, NO, NZ, OM, PG, PH, PL, PT, RO, RS, RU, SC, SD, SE, SG, SK, SL, SM, ST, SV, SY, TJ, TM, TN, TR, TT, TZ, UA, UG, US, UZ, VC, VN, ZA, ZM, ZW.

(84) Designated States (unless otherwise indicated, for every kind of regional protection available): ARIPO (BW, GH, GM, KE, LS, MW, MZ, NA, SD, SL, SZ, TZ, UG, ZM, ZW), Eurasian (AM, AZ, BY, KG, KZ, MD, RU, TJ, TM), European (AT, BE, BG, CH, CY, CZ, DE, DK, EE, ES, FI, FR, GB, GR, HR, HU, IE, IS, IT, LT, LU, LV, MC, MT, NL, NO, PL, PT, RO, SE, SI, SK, TR), OAPI (BF, BJ, CF, CG, CI, CM, GA, GN, GQ, GW, ML, MR, NE, SN, TD, TG).

Published:

- with international search report
- before the expiration of the time limit for amending the claims and to be republished in the event of receipt of amendments

(54) Title: MULTIPLE SCREEN DETECTION SYSTEMS

(57) Abstract: The present invention is a detection system and method for using the detection system in radiant energy imaging systems. In particular, the present invention is an improved detection system employing multiple screens for greater detection efficiency. And more particularly, the present invention is a detection system for detecting electromagnetic radiation having an enclosure having four adjacent walls, connected to each other at an angle and forming a rectangle and interior portion of the enclosure, a front side area and a back side area formed from the four adjacent walls and located at each end of the enclosure, at least two screens, that further include an active area for receiving and converting electromagnetic radiation into light, and a photodetector, positioned in the interior portion of the enclosure, having an active area responsive to the light.

WO 2009/059131 A1

MULTIPLE SCREEN DETECTION SYSTEMS

CROSS-REFERENCE

The present application relies upon, for priority, U.S. Provisional Application No. 60/984,640, filed on November 1, 2007.

FIELD OF THE INVENTION

The present invention relates generally to the field of radiant energy imaging systems. In particular, the present invention relates to detection systems and methods of using the detection systems in radiant energy imaging systems. And more particularly, the present invention relates to an improved detection system employing multiple screens for greater detection efficiency.

BACKGROUND OF THE INVENTION

Security systems are presently limited in their ability to detect contraband, weapons, explosives, and other dangerous objects concealed under clothing. Metal detectors and chemical sniffers are commonly used for the detection of large metal objects and some varieties of explosives, however, a wide range of dangerous objects exist that cannot be detected with these devices. Plastic and ceramic weapons developed by modern technology increase the types of non-metallic objects that security personnel are required to detect; the alternative of manual searching of subjects is slow, inconvenient, and is not well-tolerated by the general public, especially as a standard procedure in, for example, airports.

Further, radiation exposure is an important consideration in X-ray concealed object detection systems. This issue is addressed in the American National Standard "Radiation Safety for Personnel Security Screening Systems Using X-rays" (ANSI/HPS N43.17-2002). This standard permits a radiation exposure of 0.1 microsievert (10 microrem) per scan for security inspection of the general public. It is based on the recommendations of the United States National Council on Radiation Protection (NCRP) in NCRP Report No. 91, "Recommendations on Limits for Exposure to Ionizing Radiation", 1987. In this report, the NCRP states that the health risk of a radiation exposure of less than 10 microsieverts (1000 microrem) per year is negligible, and efforts are not warranted at reducing the level further. Persons employed in high security or secured facilities, or those who frequently travel by airlines, may be subjected to

1 many security examinations per year. The standard criterion thus assures that an individual
2 inspected less than about 100 times per year will not receive a non-negligible radiation dose.

3 Conventional systems and methods for detecting objects concealed on persons have
4 limitations in their design and method which prohibit them from achieving both low dose and
5 high image quality which are prerequisites of commercial acceptance. Specifically, conventional
6 prior art systems for people screening are designed such that they detect radiant energy that has
7 been transmitted through the body, scattered from the body, and/or emitted from the body. In
8 addition, in conventional people screening systems, images are produced by body characteristics
9 and any object concealed under the subject's clothing. The system operator then inspects each
10 image for evidence of concealed objects.

11 An example of such a system is described in United States Patent Number RE 28544,
12 assigned to American Science and Engineering, describes a "radiant energy imaging apparatus
13 comprising: a source of a pencil beam of X-ray radiant energy; radiant energy detecting means
14 defining a curve in fixed relationship to said source; means for scanning with said pencil beam
15 said radiant energy detecting means along said curve to provide an image signal representative of
16 the radiant energy response of the medium in a region traversed by said pencil beam along a path
17 to said detecting means; means for relatively displacing said region and an assembly comprising
18 said source and said detecting means to establish relative translating motion in a direction
19 transverse to a line joining said source and said detecting means to produce a sequence of image
20 signals representative of the radiant energy response of said region in two dimensions; and
21 means responsive to said image signals for producing an image representative of said response."

22 United States Patent Number 5,181,234, assigned to the assignee of the present invention,
23 discloses "X-ray imaging apparatus for detecting a low
24 atomic number object carried by or on a human body positioned at a distance from said apparatus
25 comprising: x-ray source for producing a pencil beam of X-rays directed toward said human
26 body; scanning means for moving the region of intersection of said pencil beam and said human
27 body over the surface of said human body in a scanning cycle, said scanning cycle being
28 sufficiently short to expose said human body to a low radiation dose; a detector assembly
29 providing a signal representative of the intensity of the X-rays scattered from said human body
30 as a result of being scanned by said scanning means, said detector assembly being disposed on a
31 same side of said human body as said X-ray source and having an active area with dimensions

1 sufficient to receive a substantial portion of said scattered X-rays to provide a coefficient of
2 variation of less than 10 percent in said signal; and display means to presenting characteristics of
3 the detector signal to an operator; wherein said scattered X-rays are distributed across said
4 detector to create an edge effect which enhances edges of said low atomic number object to
5 enable detection.”

6 In addition, prior art baggage inspection systems include detection means for both
7 transmitted and backscattered X-rays to independently produce signals from the same incident
8 beam. The separate signals may then be used to enhance each other to increase the system's
9 accuracy in recognizing low Z materials. Clearly, with the incident beam being of sufficient
10 energy to provide both transmitted and backscattered signals, the X-ray energy must be relatively
11 high, making such systems undesirable for personnel inspection. An example of such a system is
12 U.S. Patent Number 4,799,247, assigned to Annis et al., which discloses “a projection imaging
13 system for inspecting objects for highlighting low Z materials comprising: a source of
14 penetrating radiation, means for forming radiation emitted by said source into a beam of
15 predetermined cross-section and for repeatedly sweeping said beam across a line in space, means
16 for moving said object to be imaged relative to said source in a direction perpendicular to said
17 line in space, first radiant energy detector means located to be responsive to radiant energy
18 penetrating said object and emerging from said object, substantially unchanged in direction, for
19 producing first electrical signals, second radiant energy detector means located further from said
20 source than said object and responsive to radiant energy scattered by said object for producing
21 second electrical signals, third radiant energy detector means located closer to said source than
22 said object and responsive to radiant energy scattered by said object for producing third electrical
23 signals, display means responsive to at least a pair of said electrical signals for separately,
24 independently and simultaneously displaying said pair of electrical signals as a function of time”.

25 As mentioned above, conventional systems and methods have limitations that prohibit
26 them from achieving both low dose and high image quality which are prerequisites of
27 commercial acceptance. In addition, in conventional people screening systems, images are
28 produced by body characteristics and any object concealed under the subject's clothing.

29 The prior art systems are disadvantageous, however, because they do not adequately
30 detect plastics, ceramics, explosives, illicit drugs, and other non-metallic objects. One reason in
31 particular is that these materials share the property of a relatively low atomic number (low Z).

1 Low Z materials present a special problem in personnel inspection because of the difficulty in
2 distinguishing the low Z object from the background of the subject's body which also has low Z.
3 An inspection system which operates at a low level of radiation exposure is limited in its
4 precision by the small number of X-rays that can be directed against a person being searched. X-
5 ray absorption and scattering further reduces the number of X-rays available to form an image of
6 the person and any concealed objects. In prior art systems, this low number of detected X-rays
7 has resulted in unacceptably poor image quality.

8 Therefore, what is needed is a method and apparatus that increases the efficiency of a
9 detector to detect electromagnetic radiation and improve the quality of the resultant image
10 generated, thus reducing the overall amount of radiation required.

11 What is also needed is a method for using an improved radiant energy imaging system
12 with enhanced detection capabilities.

13

14 **SUMMARY OF THE INVENTION**

15 It is an object of the present invention to provide an apparatus and method for increasing
16 the efficiency of a detector to detect electromagnetic radiation and improve the quality of the
17 resultant image generated, thus reducing the overall amount of radiation required.

18 It is another object of the present invention to provide a detector configuration that
19 maximizes the efficiency of the detector material. It is yet another object of the present
20 invention to absorb more X-ray photons and thus, improve detection capability.

21 In one embodiment, the present invention is a detection system for detecting
22 electromagnetic radiation comprising: an enclosure having four adjacent walls, connected to each
23 other at an angle and forming a rectangle and interior portion of the enclosure; a front side area
24 and a back side area formed from the four adjacent walls and located at each end of the
25 enclosure; at least two screens, wherein each screen further comprises an active area for
26 receiving and converting electromagnetic radiation into light; and a photodetector, positioned in
27 the interior portion of the enclosure, having an active area responsive to the light.

28 In another embodiment, the present invention is a detection system for detecting
29 electromagnetic radiation comprising: an enclosure having four adjacent walls, connected to each
30 other at an angle and forming a rectangle and interior portion of the enclosure; a front side area
31 and a back side area formed from the four adjacent walls and located at each end of the

1 enclosure; a screen located in the front side area, further comprising an active area for receiving
2 and converting electromagnetic radiation into light; at least one screen located in the interior
3 portion of the enclosure; and a photodetector, positioned in the interior of the enclosure, having
4 an active area responsive to the light.

5 In one embodiment, the front side area is formed from at least one of the plurality of
6 screens. In another embodiment, the active area on each of the plurality of screens comprises a
7 scintillator material, where the scintillator material is calcium tungstate. In one embodiment, the
8 photodetector is a photomultiplier tube.

9 In one embodiment, the detection system enclosure is capable of receiving, but not
10 leaking electromagnetic radiation. In another embodiment, the interior surface of the adjacent
11 enclosing walls is light reflective.

12 In one embodiment, the active area of at least one of the plurality of screens is larger than
13 the active area of the photodetector and the areal density is 80 mg/cm^2 .

14 In one embodiment, the surface geometry of at least one of the plurality of screens is
15 straight or smooth. In another embodiment, the surface geometry of at least one of the plurality
16 of screens is irregular. In yet another embodiment, the surface geometry of at least one of the
17 plurality of screens is contoured. In still another embodiment, the surface geometry of at least
18 one of the plurality of screens is corrugated.

19 In another embodiment, the present invention is a radiant energy imaging system
20 comprising: a radiation source; a detection system, comprising i) an enclosure having four
21 adjacent walls, connected to each other at an angle and forming a rectangle and interior portion
22 of the enclosure; ii) a front side area and a back side area formed from the four adjacent walls
23 and located at each end of the enclosure; iii) a plurality of screens, wherein each screen further
24 comprises an active area for receiving and converting electromagnetic radiation into light; and
25 iv) a photodetector, positioned in the interior of the enclosure, having an active area responsive
26 to the light; an image processor for receiving signals from the photodetector and generating an
27 image; and a display for displaying the image generated.

28 In one embodiment, the radiant energy imaging system is a people screening system.

29 In another embodiment, the radiant energy imaging system is a baggage screening system.

BRIEF DESCRIPTION OF THE DRAWINGS

These and other features and advantages of the present invention will be appreciated, as they become better understood by reference to the following detailed description when considered in connection with the accompanying drawings, wherein:

5 Figure 1 is a front view illustration of a conventional detector enclosure, having one screen;

Figures 2a and 2b illustrate the incidence of electromagnetic radiation on a first screen of a conventional detector enclosure;

10 Figure 3 illustrates one embodiment of the detector enclosure of the present invention, having a plurality of screens, showing the incidence of electromagnetic radiation on the plurality of screens;

Figure 4 illustrates another embodiment of the detector enclosure of the present invention, having a plurality of screens, showing the incidence of electromagnetic radiation on the plurality of screens;

15 Figure 5 illustrates one embodiment of a backscatter inspection system in which any of the detector enclosures of the present invention can be implemented; and

Figure 6 illustrates one embodiment of a traditional transmission X-ray screening system in which any of the detector enclosures of the present invention can be implemented.

DETAILED DESCRIPTION OF THE INVENTION

20 The present invention is directed towards several embodiments of an electromagnetic radiation detector in which a plurality of screens is employed. The present invention is directed towards a detection system enclosure having at least one screen. Electromagnetic radiation is absorbed by the screen which emits light photons that are detected by a photomultiplier tube
25 located within the enclosure. In one embodiment, the detection system of the present invention has one screen located at the front of the enclosure and at least one screen located in the interior of the enclosure. In one embodiment, the at least one screen comprises an active area for receiving and converting electromagnetic radiation into light (photons). In one embodiment, the active area of the at least one screen comprises a scintillator material. In one embodiment, the
30 scintillator material is calcium tungstate.

In one embodiment, the at least one screen has a thickness (areal density) of 80 mg/cm². In one embodiment, the surface geometry of the at least one screen is straight or smooth. In one embodiment, the surface geometry of the at least one screen is irregular. In another embodiment, the surface geometry of the at least one screen is contoured. In another embodiment, the surface geometry of the at least one screen is corrugated; a corrugated surface geometry provides a greater surface area for receiving and converting electromagnetic radiation into light, by allowing for an increase in the electromagnetic radiation path length without increasing the light output path length, for maximum detection efficiency. It should be understood by those of ordinary skill in the art that any surface geometry may be used for the screen to increase the amount of electromagnetic radiation absorbed.

The present invention is also directed towards the use of at least one screen in the interior of the enclosure, thus increasing the amount of electromagnetic radiation reaching the detector, and subsequently, the amount of photons reaching the photomultiplier. In one embodiment, the at least one screen located in the interior of the enclosure has identical specifications to the screen located in the front of the enclosure. In one embodiment, the at least one screen positioned in the interior of the enclosure is different from the screen located in the front of the enclosure, in terms of at least one of chemical composition, surface geometry, thickness and energy response. The use of a screen at the front of the enclosure and the at least one screen in the interior of the enclosure increases the amount of electromagnetic radiation absorbed and therefore, the number of photons generated, further improving detection capability, and thus image quality.

Thus, the present invention is directed towards a detector configuration that maximizes the efficiency of the detector material. Detection efficiency is a measure of the efficiency of the detector screen, or, the probability that electromagnetic radiation will be absorbed by the screen to produce light photons detectable by the photomultiplier tube. X-ray detectors need to interact with incident x-ray photons to record their presence; x-rays that pass through the detector without interaction are wasted. Detection efficiency is mainly determined by the interaction probability of the photons with the detector material and the thickness of the material. The following equation can be used to calculate the efficiency of a detector:

$$I=I_0 * e^{-\mu x}$$

where I_0 is the number of photons of a certain energy incident or entering the slab of material; x is the thickness of the slab, I is the number of photons that have passed through a layer of thickness x , and μ is the linear attenuation coefficient of the material for photons of this particular energy. The photons that do not get through have interacted within the slab of material and are either absorbed or scattered. The number of photons absorbed by a certain thickness is the difference $I_0 - I$. However, instead of calculating for different I 's, the ratio of $(I_0 - I)/I$ is calculated and it is called the "Percent Absorption." Conventional screens typically achieve far less than 100% efficiency. The present invention is directed toward absorbing more of the otherwise wasted X-ray photons and thereby improving the detection capability.

In another embodiment, the present invention is also directed towards a detection system enclosure that further comprises a photo-multiplier tube, positioned in the interior of the enclosure, having an active area responsive to the light. In another embodiment, the active area of the at least one screen is larger than the active area of the photo-multiplier tube so that the amount of electromagnetic radiation absorbed is maximized.

The present invention is directed towards multiple embodiments. Language used in this specification should not be interpreted as a general disavowal of any one specific embodiment or used to limit the claims beyond the meaning of the terms used therein. Reference will now be made in detail to specific embodiments of the invention. While the invention will be described in conjunction with specific embodiments, it is not intended to limit the invention to one embodiment.

Figure 1 is a front view illustration of a conventional detector enclosure, having one screen. Detector 100 comprises an enclosure having four adjacent walls, 102a, 102b, 102c, and 102d, connected to each other at an angle. The four adjacent walls 102a, 102b, 102c, and 102d form a rectangular shape. Adjacent walls 102a, 102b, 102c, and 102d further form a front side area 106 and a back side area 104 at the ends of the enclosure. The enclosure formed from adjacent walls 102a, 102b, 102c, 102d, front side area 106 and back side area 104 is capable of receiving, but not leaking electromagnetic radiation, thereby blocking the exit of incoming radiation from a radiation source. The ability of the enclosure to receive, and not leak, radiation, is facilitated by the light reflective interiors of the enclosing walls. Typically, the interiors of walls 102a, 102b, 102c, and 102d are painted white so that they are highly light reflective.

The front side area 106 of detector enclosure 100 is used for receiving radiation and thus faces the object under inspection when in use in an exemplary scanning system. Front side area 106 further comprises a screen 107. Detector enclosure 100 further comprises a photo-detector 108, placed in the interior of the enclosure proximate to back side area 104. The photo-detector 108 is a photomultiplier tube. Photomultiplier tubes are well-known to those of ordinary skill in the art and will not be discussed herein.

Figures 2a and 2b illustrate the incidence of electromagnetic radiation on a first screen of a conventional detector enclosure. In operation, the screening system directs electromagnetic radiation from a source toward a subject or object under inspection such that the X-rays are incident upon the subject or object. The X-rays are then, depending upon the intensity of the X-ray and the type of inspection system being employed, scattered from or transmitted through the subject or object under inspection. The radiation source and the nature of the X-ray beam are described in detail with respect to Figures 5 and 6 below and will not be discussed further.

Now referring to Figure 2a scattered or transmitted X-rays 210 reach the detector enclosure 200 and first impinge upon screen 207. Screen 207 absorbs at least a portion of the scattered or transmitted X-rays 210 and converts the X-rays into light photons 206 in the interior of detector enclosure 200. As shown in Figure 2b, however, some of the X-rays are not absorbed and thus pass through screen 207. In addition, in a conventional detector enclosure with only one front screen, at least a portion of photons 206 reflect off of the highly reflective interior walls of the enclosure and are subsequently detected by photomultiplier tube 208.

Referring to Figure 3, the present invention is a detector enclosure comprising at least one additional screen (not shown in Figures 2a and 2b) in the interior of the enclosure. The at least one additional screen further increases the exposure rate of the scattered or transmitted X-rays 210. The net effect of the at least one additional screen is to increase the photo-detection efficiency of photomultiplier tube 208 by absorbing more electromagnetic radiation, subsequently converting that radiation to light, and thus, providing the photomultiplier tube with a stronger signal to detect.

Figure 3 illustrates one embodiment of the detector of the present invention, having a plurality of screens. Detector enclosure 300 is similar to the enclosure described with respect to Figure 1, in that it comprises four adjacent side walls, the proximal sides of which form a front side area 306 and distal sides of which form a back side area 304. One of ordinary skill in the art

should appreciate that the detector enclosure of Figure 1 can be modified to create the embodiment shown in Figure 3.

Referring now to Figure 3, first screen 307a is located on the front side area 306 of detector enclosure 300. In one embodiment, second and third screens 307b and 307c are positioned inside the detector enclosure 300. The X-rays scattered from or transmitted through the subject or object under inspection 310 first impinge upon first screen 307a of detector enclosure 300. Some of the scattered or transmitted X-rays, however, are not absorbed by first screen 307a and thus pass through first screen 307a.

To increase detection efficiency, in one embodiment, detector enclosure 300 further comprises second and third screens, 307b and 307c, respectively in the interior of the enclosure. Second and third screens, 307b and 307c, respectively, further increase the exposure rate and thus, absorption of the scattered or transmitted X-rays 310. The overall effect of the first, second, and third screens is an increase in the photo-detection efficiency of photomultiplier tube 308 by absorbing more electromagnetic radiation, subsequently converting that radiation to light, and thus, providing the photomultiplier tube with a stronger signal to detect.

In one embodiment, first screen 307a comprises an active area for receiving and converting electromagnetic radiation into light (photons). In one embodiment, first screen 307a is a fluorescent chemical screen. In one embodiment, scintillators in the fluorescent chemical screen 307a detect a large fraction of the incident radiation, produce significant light output to the photomultiplier tube, and exhibit a temporal decay time which is short compared to the pixel to pixel scanning rate of the radiation beam.

In one embodiment, the fluorescent chemical screen includes calcium tungstate. Generally, a calcium tungstate screen has a relatively short decay time of 10 microseconds that allows rapid scanning of the radiation beam with minimal image degradation. The calcium tungstate screen is capable of detecting approximately 70% of the backscattered or transmitted radiation, and thus, produces approximately 250 usable light photons per 30 KeV X-ray.

Additionally, the use of a thicker screen enables the detection of more of the radiation incident upon the detector at the expense of lower light output. In one embodiment, the areal density of the screen is 80 milligrams per square centimeter.

In one embodiment, the at least one screen located in the interior of the enclosure has identical specifications to the screen located in the front of the enclosure. Thus, in one

embodiment, second and third screens 307b and 307c, respectively, are identical to first screen 307a. In one embodiment, the at least one screen positioned in the interior of the enclosure is different from the screen located in the front of the enclosure, in terms of at least one of chemical composition, surface geometry, thickness and energy response. Thus, in one embodiment,
5 second and third screens 307b and 307c, respectively, are different from first screen 307a.

Although exemplary screens have been described above, it should be noted that the characteristics of the screen can vary widely in terms of chemical composition, surface geometry, thickness and energy response, and that any type of screen may be used in the present invention, as would be evident to those of ordinary skill in the art.

10 Figure 4 illustrates another embodiment of the detector enclosure of the present invention, having a plurality of screens. In one embodiment, the surface geometry of the at least one screen is straight or smooth. In one embodiment, the surface geometry of the at least one screen is irregular. In another embodiment, the surface geometry of the at least one screen is contoured. In another embodiment, the surface geometry of the at least one screen is corrugated.
15 A corrugated surface geometry provides a greater surface area for receiving and converting electromagnetic radiation into light, by allowing for an increase in the electromagnetic radiation path length without increasing the light output path length, for maximum detection efficiency. It should be understood by those of ordinary skill in the art that any surface type may be used for the screen to increase the amount of electromagnetic radiation absorbed.

20 In one embodiment, screen 407 located on front side area 404 of detector enclosure 400 is corrugated. The corrugated surface of screen 404 provides a greater surface area for absorbing scattered or transmitted electromagnetic radiation 410, incident upon the detector enclosure 400. It should be noted that because light generated in spaces 411, defined by screens 407 and 408, cannot escape easily, the detection efficiency, or effective detection area is reduced.

25 Figure 5 illustrates one embodiment of a scanning system in which any of the detector enclosures of the present invention can be implemented. In one embodiment, the detector enclosure of the present invention is employed in a backscatter X-ray scanning system, such as but not limited to a people screening system. In one embodiment, inspection system 500 comprises radiation source 508 and at least one detector enclosure 502. As described in detail
30 above, the at least one detector enclosure 502 may comprise any number of arrangements including, but, not limited to at least one detector screen. In addition, at least one detector

enclosure 502, in another embodiment, may comprise any number of arrangements including, but, not limited to a plurality of detector screens. While various arrangements of detectors will not be repeated herein, it should be understood by those of ordinary skill in the art that any number of detector arrangements can be employed, as described above and the exemplary
5 embodiment is not intended to limit the present invention.

Referring back to Figure 5, X-ray source 508 is used to generate radiation. In one embodiment, X-ray source 508 is employed to generate a narrow pencil beam 506 of X-rays directed towards an object or subject under examination 504. In one embodiment, pencil beam is formed with the integration of an x-ray tube, a mechanical chopper wheel, and a slit.

10 In one embodiment, x-ray source 508 operates with an empirically and theoretically determined optimum X-ray tube potential of 50 KeV and 5 milliamps, resulting in X-rays of approximately 30 KeV. The vertical and horizontal dimension of the X-ray beam is approximately six millimeters (6 mm) where it strikes subject 504. Subject 504 is a body that is being subjected to X-ray imaging. In one embodiment, subject 504 is a human. In another
15 embodiment, subject 504 is an object. Initially, X-ray beam 506 strikes only the body of subject 504. Many of the X-rays penetrate a few centimeters into the body, interact by Compton scattering, and exit the body through the same surface that they entered. X-ray sensitive detector enclosures 502 are placed symmetrically around incident X-ray pencil beam to detect backscattered X-rays 510 and provide an electronic signal characteristic of the X-ray reflectance.
20 It should be understood to those of ordinary skill in the art that any number of ionizing radiation sources may be used, including but not limited to gamma radiation, electromagnetic radiation, and ultraviolet radiation.

Detectors 502 are positioned for uniform X-ray detection on all sides of X-ray beam 506. In one embodiment, arrays of detectors 502 are placed around source 508 for uniform detection
25 of backscattered rays 510. Detectors 502 include an enclosure capable of enclosing or "trapping" scattered rays 510. A photo-detector generates electronic signals in response to detected rays that are initially converted into light. Details about the structure and operation of several embodiments of a detector 502 are discussed in detail with respect to Figures 1-4 and will not be repeated herein.

30 In one embodiment, each detector 502 produces electronic signals which are directed to a processor. The processor analyzes the received signals and generates an image on a display

means 512. The intensity at each point in the displayed image corresponds to the relative intensity of the detected scattered X-rays. In one embodiment, X-ray source 508 communicates synchronization signals to the processor. The processor analyzes the detected signals and compares them to the synchronization signals to determine the display image.

5 In one embodiment, display means 512 is a monitor and is employed to display graphical images signaled by the processor. Display means 512 can be any display or monitor as commonly known in the art, including a cathode ray tube monitor or an LCD monitor. In one embodiment, the digitized scatter image displayed by display means 512 preferably consists of 480 rows by 160 columns with 8 bits per pixel.

10 Referring back to Figure 5, detectors 502 are separated by an opening through which x-ray beam 506 passes before striking subject 504. In one embodiment, detectors 502 can move in a vertical direction while X-ray beam 506 moves in a horizontal direction by movement of X-ray source 508 in the horizontal direction. However, the placement and movement of detectors 502 and source 508 is not limited to the description provided herein. In other embodiments, detectors
15 502 and source 508 can be placed and moved by any method as is commonly known in the art. The intersection of x-ray beam 506 and subject 504 defines an image picture element (pixel) of a specified area.

Figure 6 illustrates another embodiment of a scanning system in which any of the detector enclosures of the present invention can be implemented. In another embodiment, the
20 scanning system is a traditional X-ray scanning system, in which X-rays are transmitted through the object under inspection. In one embodiment, the traditional transmission X-ray scanning system is a baggage scanning system.

In one embodiment, inspection system 600 comprises radiation source 608 and at least one detector enclosure 602. As described in detail above, the at least one detector enclosure 602
25 may comprise any number of arrangements including, but, not limited to at least one detector screen. In addition, at least one detector enclosure 602, in another embodiment, may comprise any number of arrangements including, but, not limited to a plurality of detector screens. While various arrangements of detectors will not be repeated herein, it should be understood by those of ordinary skill in the art that any number of detector arrangements can be employed, as described
30 above and the exemplary embodiment is not intended to limit the present invention.

Referring back to Figure 6, X-ray source 608 is used to generate radiation. In one embodiment, X-ray source 608 is employed to generate a narrow pencil beam 606 of X-rays directed towards an object or subject under examination 604. In one embodiment, pencil beam is formed with the integration of an x-ray tube, a mechanical chopper wheel, and a slit.

5 Object 604 is an item that is subjected to X-ray imaging. In one embodiment, object 604 is a piece of luggage or carry-on baggage. Initially, X-ray beam 606 strikes only the object 604. Many of the X-rays are transmitted through the object, interact by Compton scattering, and exit the object through the opposite surface that they entered. X-ray sensitive detector enclosures 602 are placed symmetrically around incident X-ray pencil beam to detect transmitted X-rays 610
10 and provide an electronic signal characteristic of the X-ray transmission.

It should be understood to those of ordinary skill in the art that any number of ionizing radiation sources may be used, including but not limited to gamma radiation, electromagnetic radiation, and ultraviolet radiation.

Detectors 602 are positioned for uniform X-ray detection on all sides of X-ray beam 606.
15 In one embodiment, arrays of detectors 602 are placed around object 604 for uniform detection of transmitted rays 610. Detectors 602 include an enclosure capable of enclosing or “trapping” scattered rays 610. A photo-detector generates electronic signals in response to detected rays that are initially converted into light. Details about the structure and operation of several embodiments of a detector 602 are discussed in detail with respect to Figures 1-4 and will not be
20 repeated herein.

In one embodiment, each detector 602 produces electronic signals which are directed to a processor. The processor analyzes the received signals and generates an image on a display means 612. The intensity at each point in the displayed image corresponds to the relative intensity of the detected transmitted X-rays. In one embodiment, X-ray source 608
25 communicates synchronization signals to the processor. The processor analyzes the detected signals and compares them to the synchronization signals to determine the display image. In one embodiment, display means 612 is a monitor and is employed to display graphical images signaled by the processor. Display means 612 can be any display or monitor as commonly known in the art, including a cathode ray tube monitor or an LCD monitor. In one embodiment,
30 the digitized image displayed by display means 612 preferably consists of 480 rows by 160 columns with 8 bits per pixel.

In one embodiment, detectors 602 can move in a vertical direction while X-ray beam 606 moves in a horizontal direction by movement of X-ray source 608 in the horizontal direction. However, the placement and movement of detectors 602 and source 608 is not limited to the description provided herein. In other embodiments, detectors 602 and source 608 can be placed
5 and moved by any method as is commonly known in the art. The intersection of x-ray beam 606 and object 604 defines an image picture element (pixel) of a specified area.

The above examples are merely illustrative of the many applications of the system of present invention. *The appended claims define distinctly and in explicit terms the subject matter of the invention for which an exclusive privilege or property is claimed.*

10

Therefore, the present examples and embodiments are to be considered as illustrative and not restrictive, and the invention is not to be limited to the details given herein, but may be modified within the scope of the appended claims.

CLAIMS

1. A detection system for detecting electromagnetic radiation comprising:
an enclosure having four adjacent walls, connected to each other at an angle
5 and forming an interior portion of the enclosure;
at least two screens, wherein each screen further comprises an active area for
receiving and converting electromagnetic radiation into light, and one of the screens is
positioned at the front of the enclosure and one of the screens is positioned in the
interior of the enclosure; and
10 a photodetector, positioned in the interior portion of the enclosure, having an
active area responsive to the light.
2. The detection system of claim 1 wherein the enclosure formed from the adjacent
walls, has a front side area and back side area.
15
3. The detection system of claim 1 wherein the interior surface of the adjacent
enclosing walls is light reflective.
4. The detection system of claim 2 wherein the front side area is formed from at least
20 one of the plurality of screens.
5. The detection system of claim 1 wherein the active area on each of the plurality of
screens comprises a scintillator material.
- 25 6. The detection system of claim 4 wherein the scintillator material is calcium
tungstate.
7. The detection system of claim 1 wherein the active area of at least one of the
plurality of screens is larger than the active area of the photodetector.
30
8. The detection system of claim 1 wherein the areal density of at least one of the
plurality of screens is 80 mg/cm^2 .
9. The detection system of claim 1 wherein the surface geometry of at least one of the
35 plurality of screens is straight or smooth.

10. The detection system of claim 1 wherein the surface geometry of at least one of the plurality of screens is irregular.
- 5 11. The detection system of claim 1 wherein the surface geometry of at least one of the plurality of screens is contoured.
12. The detection system of claim 1 wherein the surface geometry of at least one of the plurality of screens is corrugated.
- 10 13. The detection system of claim 1 wherein the photodetector is a photomultiplier tube.
14. A radiant energy imaging system comprising:
- 15 a radiation source;
- a detection system, comprising an enclosure having four adjacent walls, connected to each other at an angle and forming an interior portion of the enclosure; at least two screens, wherein each screen further comprises an active area for receiving and converting electromagnetic radiation into light, and one of the screens is
- 20 positioned at the front of the enclosure and one of the screens is positioned in the interior of the enclosure; and a photodetector, positioned in the interior of the enclosure, having an active area responsive to the light;
- an image processor for receiving signals from the photodetector and generating an image; and
- 25 a display for displaying the image generated.
15. The radiant energy imaging system of claim 14 wherein the system is a people screening system.
- 30 16. The radiant energy imaging system of claim 14 wherein the system is a baggage screening system.

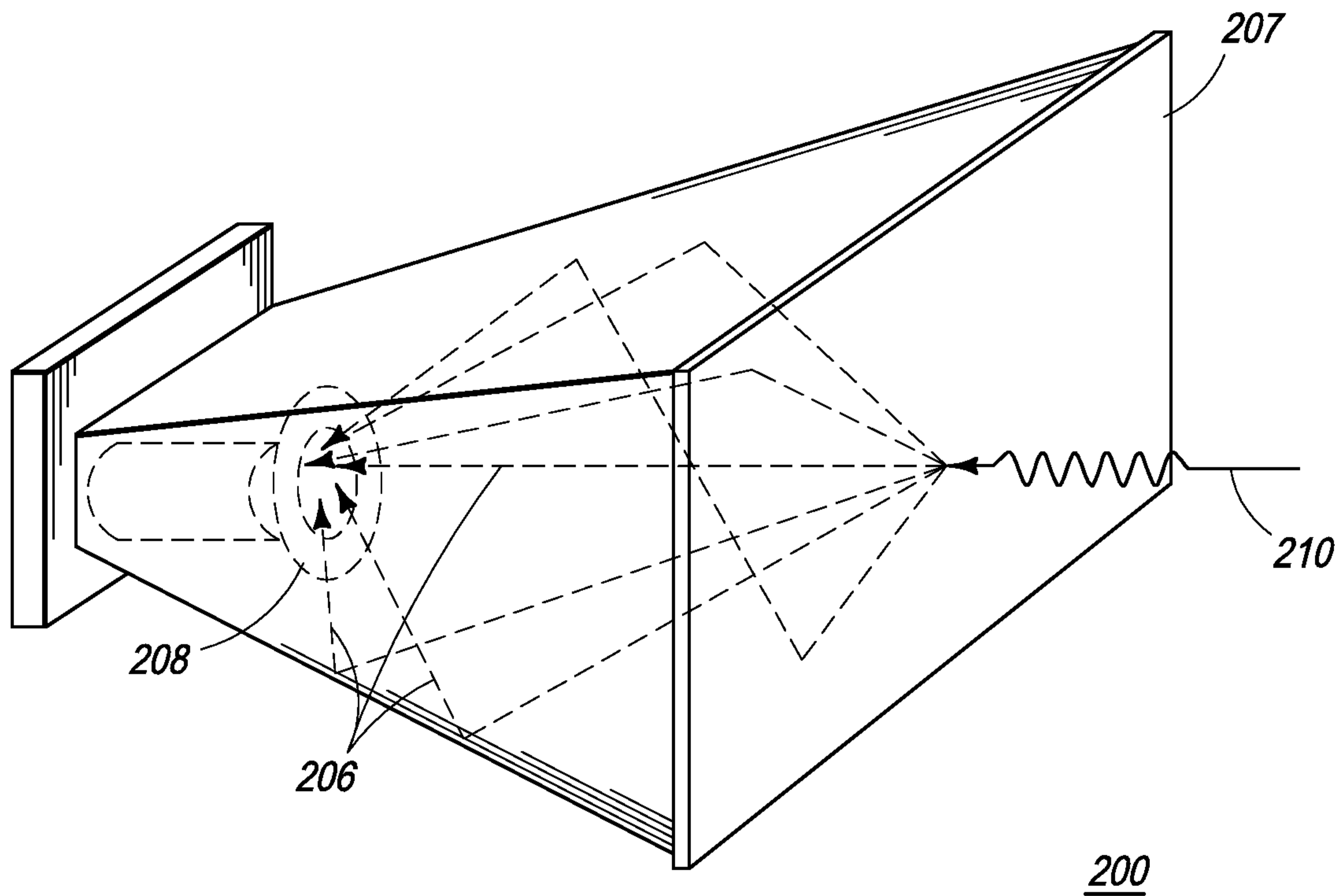
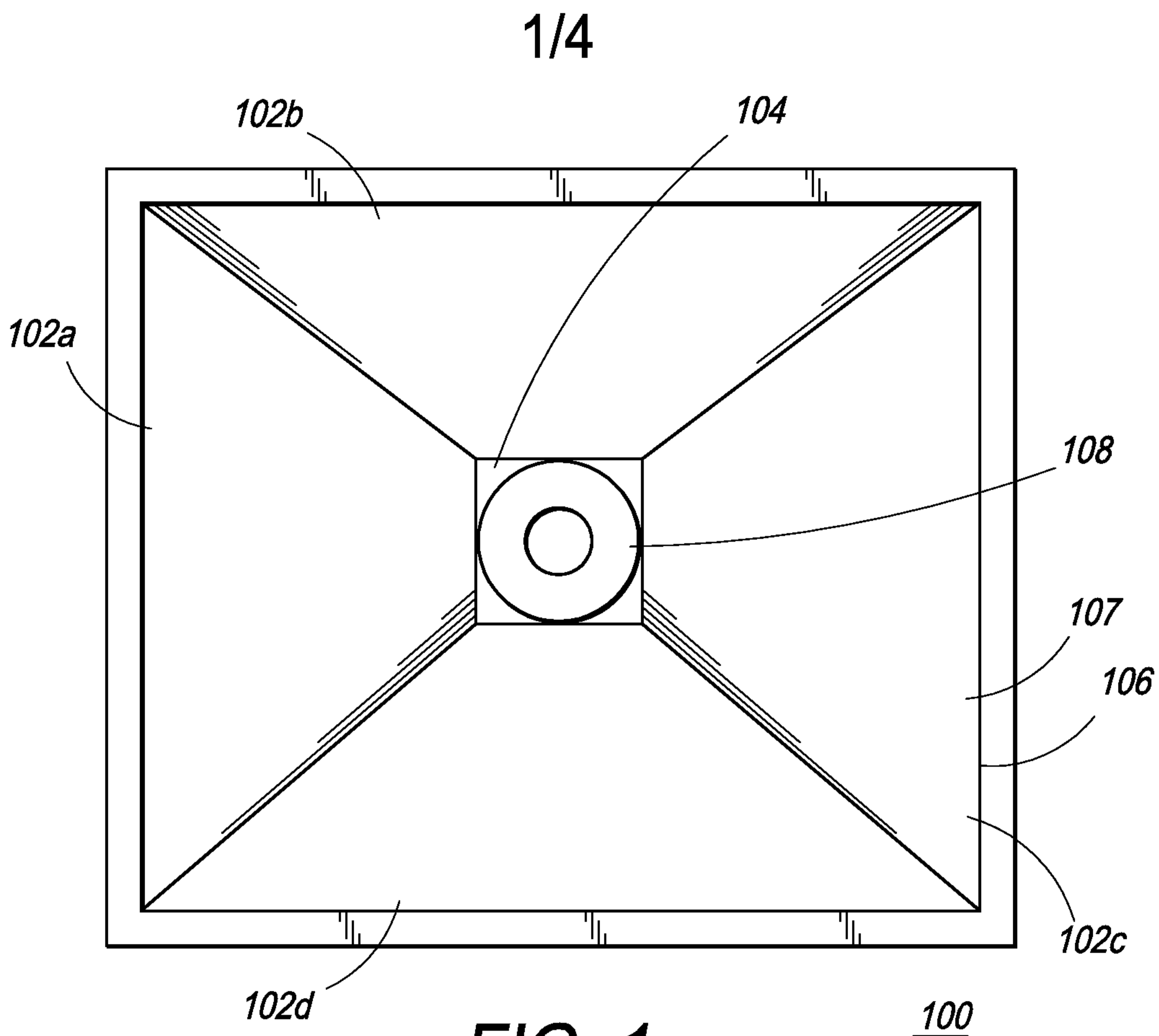

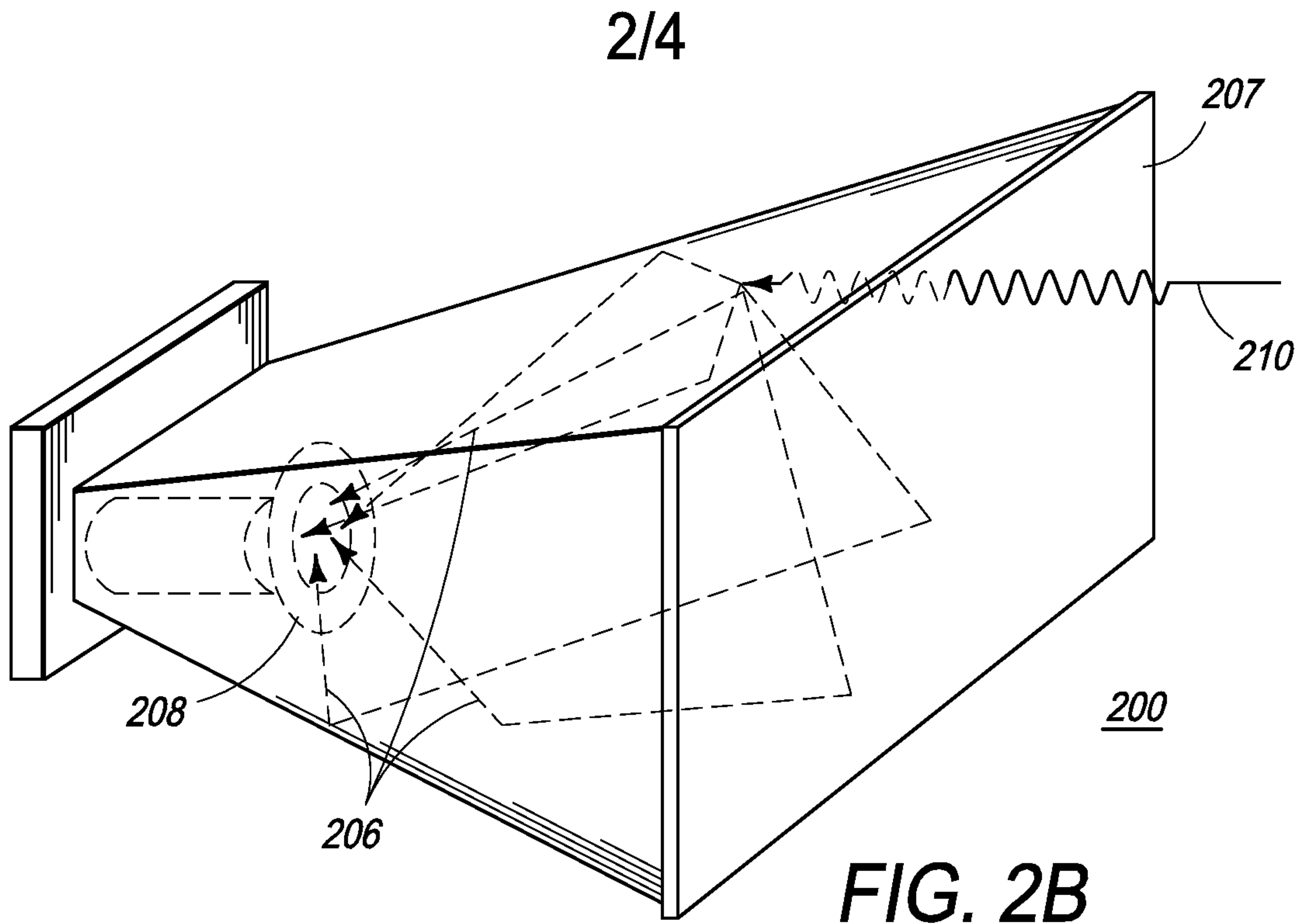

FIG. 2B
Prior Art

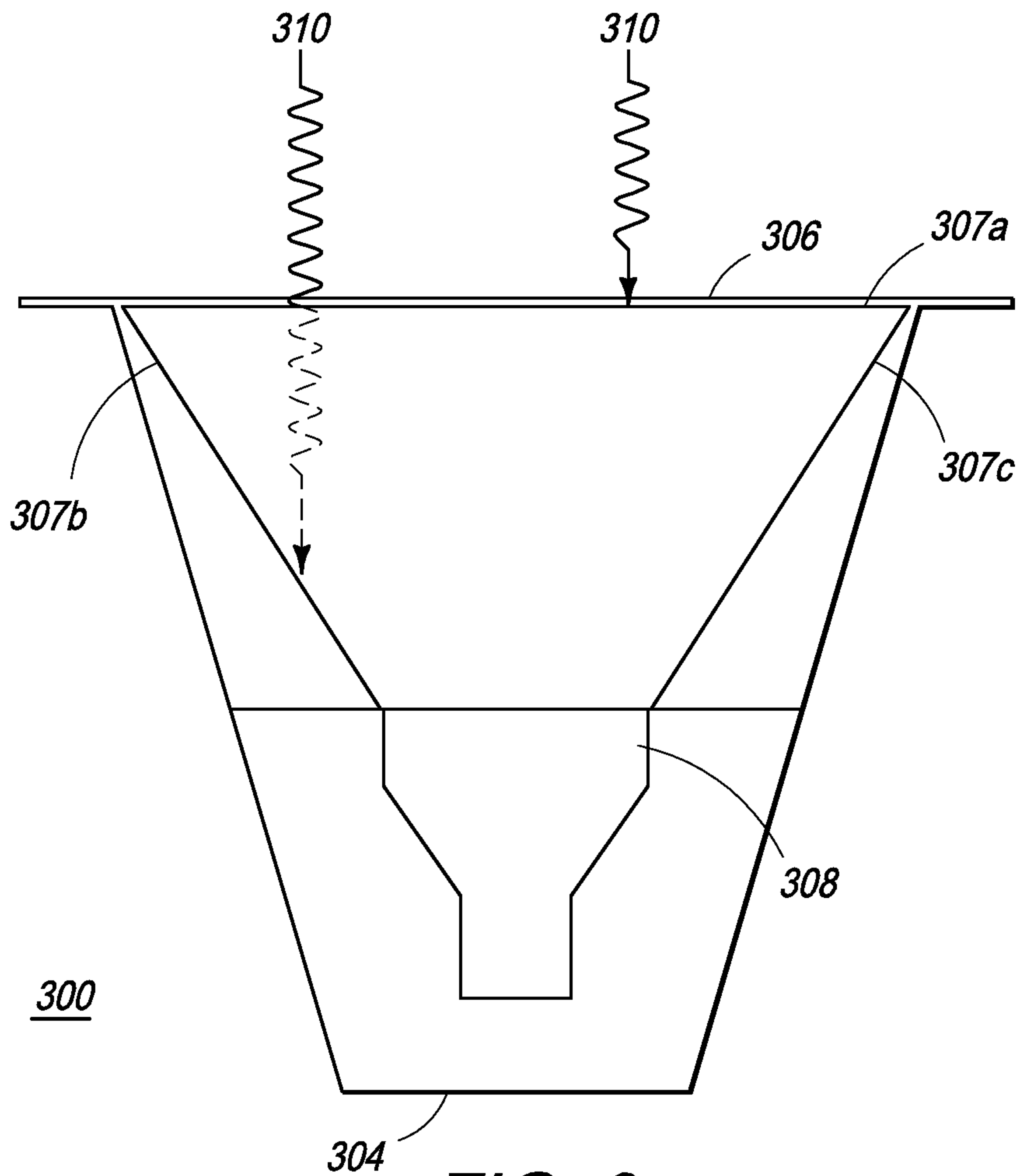

FIG. 3

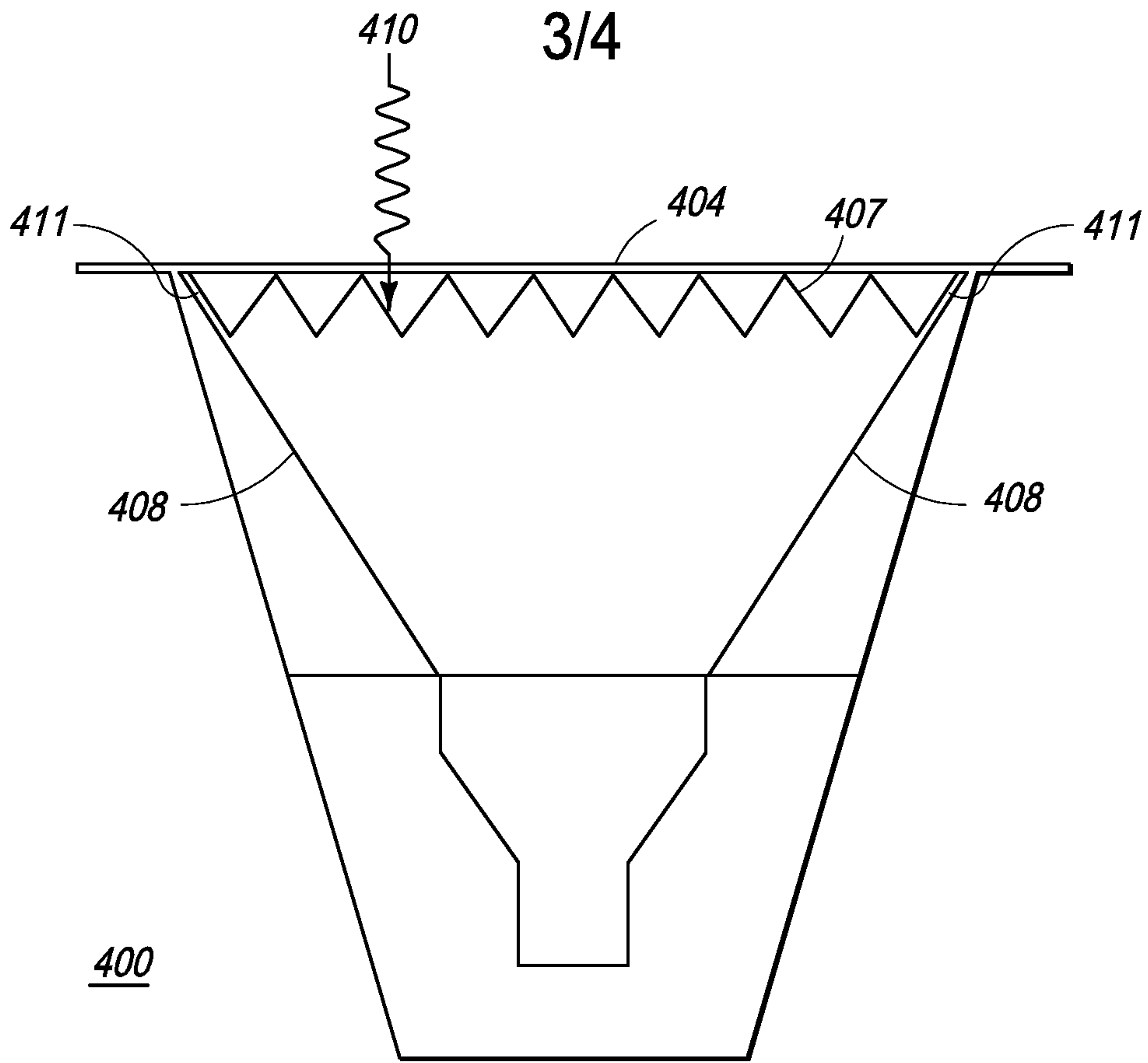

FIG. 4

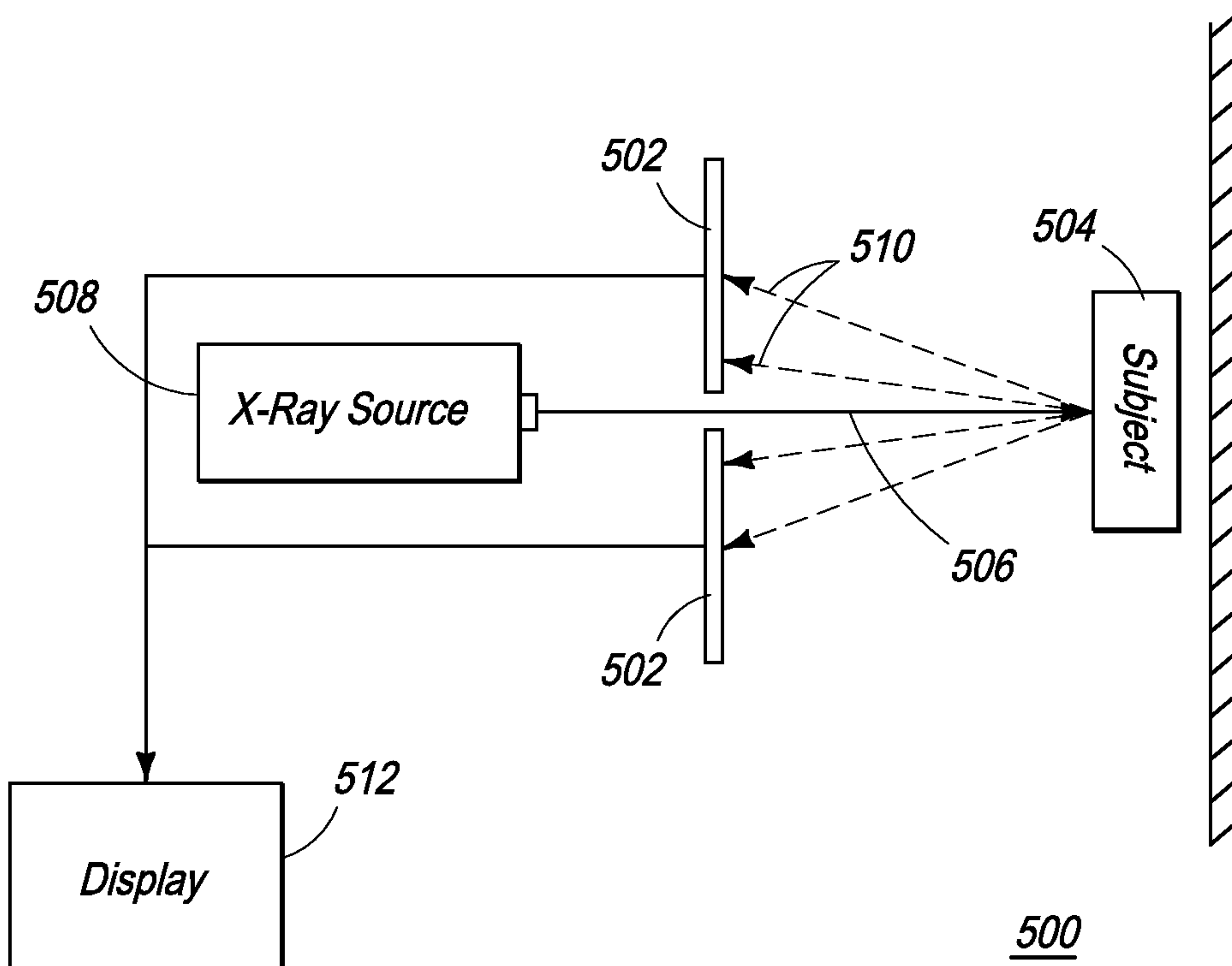

FIG. 5

4/4

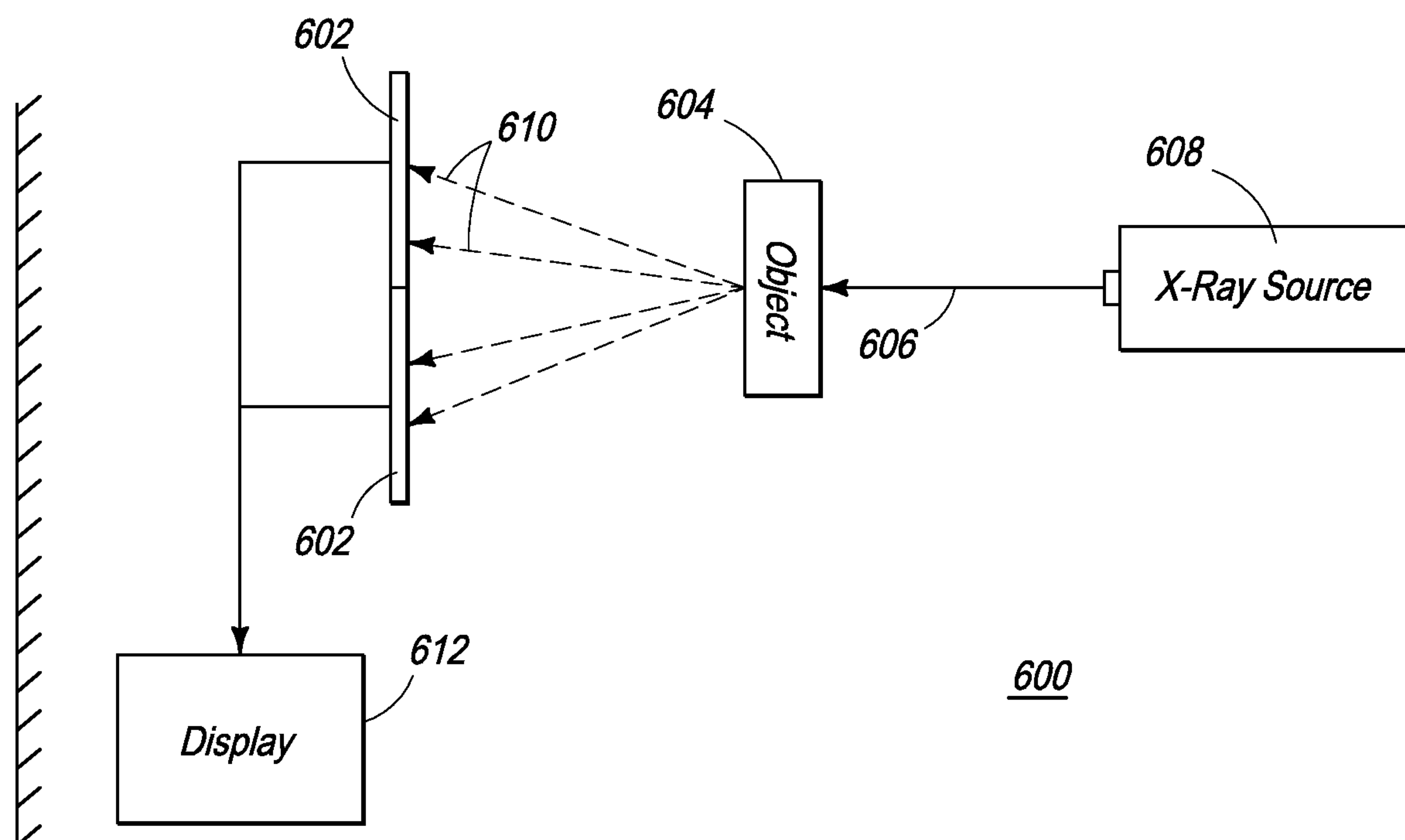

FIG. 6

