

Aug. 24, 1965

B. W. VAN HENNIK
BOMBING GAME APPARATUS WITH LIGHT BEAM
PROJECTING SIMULATED ANTI-AIRCRAFT GUN

3,202,425

Filed June 10, 1964

2 Sheets-Sheet 1

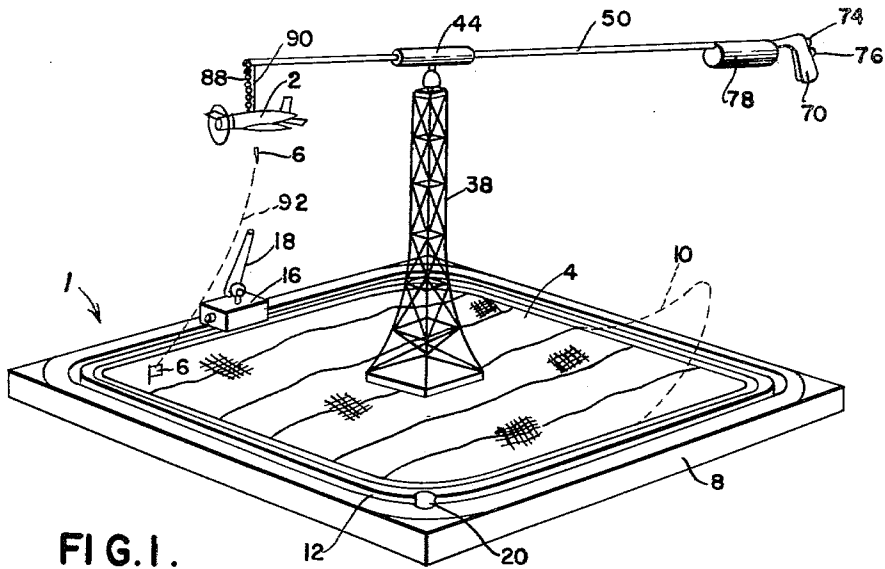

FIG. 1.

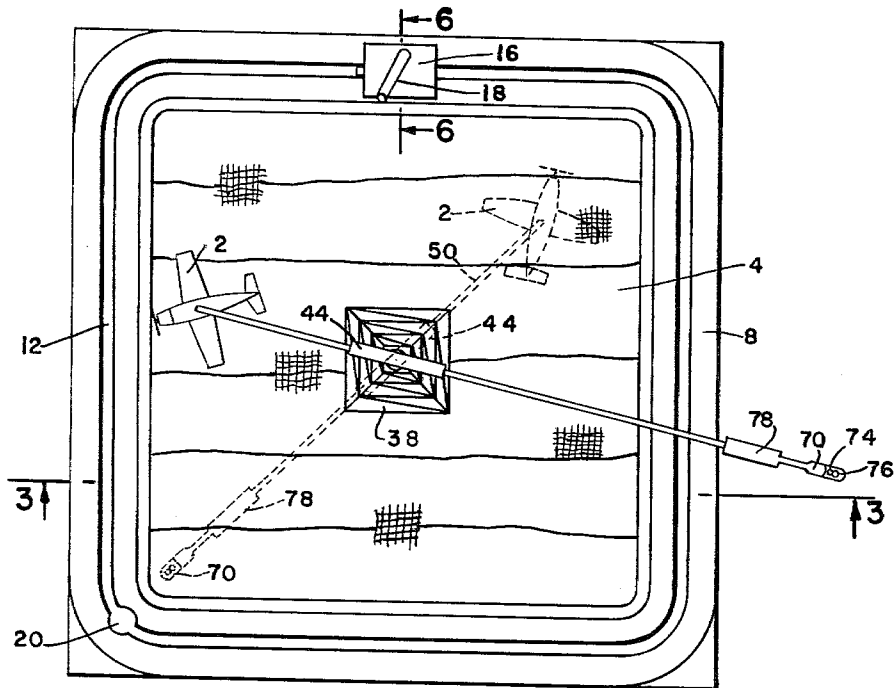

FIG. 2.

INVENTOR
Burtis W. VanHennik

BY *Clive H. Bramson*

ATTORNEY

Aug. 24, 1965

B. W. VAN HENNIK
BOMBING GAME APPARATUS WITH LIGHT BEAM
PROJECTING SIMULATED ANTI-AIRCRAFT GUN

3,202,425

Filed June 10, 1964

2 Sheets-Sheet 2

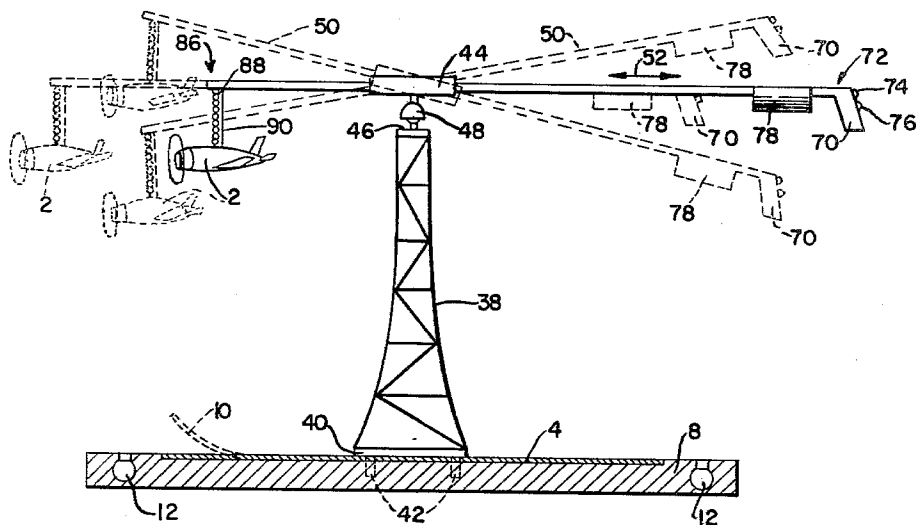

FIG. 3.

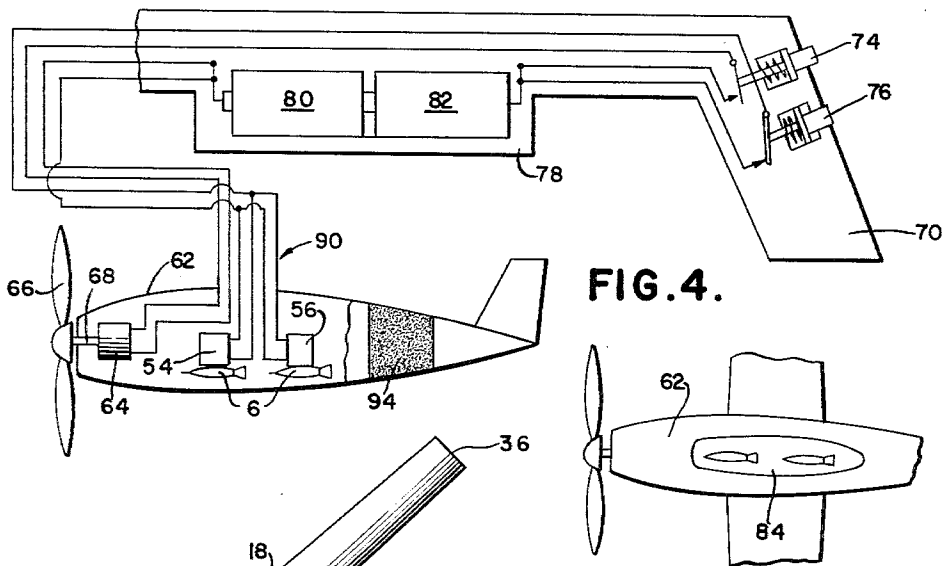

FIG. 4.

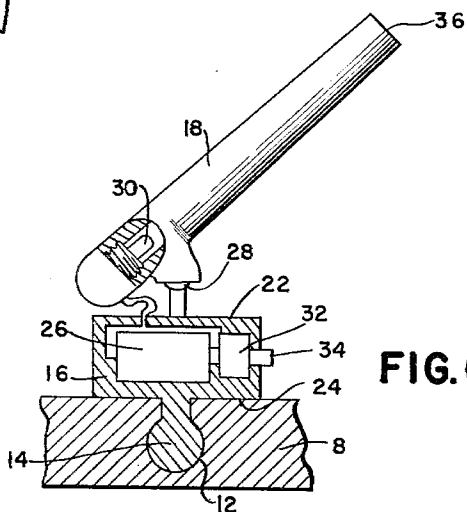

FIG. 5.

FIG. 6.

INVENTOR
Burtis W. Van Hennik

BY *Clive H. Bramson*

ATTORNEY

1

3,202,425

BOMBING GAME APPARATUS WITH LIGHT BEAM PROJECTING SIMULATED ANTI-AIRCRAFT GUN

Burtis W. Van Hensik, 99 Lenore Lane, Farmingville, N.Y.

Filed June 10, 1964, Ser. No. 374,097
4 Claims. (Cl. 273-101.1)

This invention relates generally to amusement devices and more particularly to a war game apparatus especially suited for the entertainment of children, said apparatus including a model bombing airplane maneuverable by a first player and a laser simulating light-beam-emitting-gun operated by a second player, each player concurrently seeking to destroy the weapon of the other.

Accordingly, and consonant with the foregoing, the instant invention has for an object the provision of a bombing game apparatus including a model airplane having at least one bomb remotely releasable by a player, said player being able to maneuver the airplane over a target area, whereby a bomb, when released, will fall in a trajectory path to the target area.

Another object of the present invention resides in the provision of a light-emitting anti-aircraft gun which is mobile with respect to the periphery of the target area and which, when properly aimed by the opposing player, will with the light-beam, strike the bombing airplane and thus simulate the destruction thereof.

Another object of this invention is to provide a game-board which has a pictorial target superposed surfacedly thereof, said target being removable and capable of being replaced by another pictorial target.

A further object of the present invention resides in the provision of a bombing game apparatus of the foregoing character wherein the model bombing airplane includes an electrically-motivated propellor and electro-magnetic bomb supports, each of the latter being operable while the player conducts the airplane through various attack and defensive aerial maneuvers.

Another general object of the present invention is to provide a device of the described character which will be simple in structure, economical of manufacture, and entertaining and interesting in use.

Other objects and advantages of the instant bombing game apparatus will be set forth in part hereinafter and in part will be obvious herefrom, or may be learned by practice of the invention, the same being realized and attained by means of the structure defined and pointed out in the appended claims.

The accompanying drawings referred to herein and constituting a part hereof, illustrate one embodiment of the invention, and together with the description, serve to explain the principles of the invention.

FIGURE 1 is a perspective view of the game apparatus showing the gameboard, the anti-aircraft gun, the model airplane and supporting structure therefore, all operatively positioned;

FIGURE 2 is a plan view of the apparatus, the maneuverability of the plane being shown therein;

FIGURE 3 is a side elevational cross-sectional view of the gameboard taken along line 3-3 of FIGURE 2, the bombing airplane being shown in multiple positions and attached to the guiding tubular member, said tubular member being illustrated pivotally supported by a pylon tower extending upwardly of the gameboard;

FIGURE 4 is an enlarged schematic view of the handle means, the battery casing adjacent thereto and the model airplane, the wiring connections between the electrical components thereof being illustrated;

FIGURE 5 is an enlarged fragmentary plan view of the bottom of the model airplane showing the bomb-bay openings and the bombs adjacent thereto; and

2

FIGURE 6 is an enlarged cross-sectional view of the anti-aircraft gun and the slidable reception of the tongue thereof within the peripheral groove of the gameboard, said view being taken along line 6-6 of FIGURE 2.

Referring now in detail to the present preferred embodiment of the invention illustrated in the accompanying drawings, FIGURE 1 shows the bombing game apparatus designated generally by numeral 1 and FIGURES 2 and 3, which present the instant game apparatus in plan and elevational view forms, respectively, are especially directed to showing the model bombing airplane 2 disposed in various positions above the target area 4 whereby predetermined locations of said target area may be "destroyed" by a bomb 6 remotely releasable by a player in accordance with the disclosure hereinbelow following.

As shown in the aforesaid figures, the bombing game apparatus will be seen to comprise substantially rectangular gameboard 8 having a removably superposed target area 4 positioned surfacedly thereof. With reference to FIGURES 1 and 3 the removability of the target area which is imprinted on sheet paper, plastic or other suitable material, is shown in broken line designation 10, said sheet material being liftable from the board 8 as shown.

Groove 12 is provided in board 8 and is disposed peripherally of target area 4 as will be observed by reference to FIGURE 2. The groove shown is circular in cross-section, the function thereof being to slidably receive and retain spherical tongue 14 which extends downwardly of housing 16 which supports gun barrel 18, the latter being shown in FIGURE 6 and further described hereinbelow. Accordingly, the groove 12 may be modified into cross-sections other than circular, to slidably accept and retain tongue 14 should the latter be formed of similarly modified configurations. Groove 12 is provided with an entrance opening 20 into which the spherical tongue 14 is initially inserted, after which the tongue, although precluded against vertical movement, is free to slide horizontally within groove 12, the latter acting as a monorail permitting the housing 16 and gun barrel 18 to be manually moved peripherally of the target area.

Said battery housing 16, as illustrated in FIGURE 6 of the drawings, includes top and bottom walls 22 and 24, respectively, and contains a battery 26 therewithin and aforesaid tubular gun barrel 18 is swivelly mounted by means of knuckle joint 28 upon said top wall 22 of the housing. Electrical light bulb 30 is mounted within the gun barrel and will be seen by virtue of the cut-away portion of the barrel shown in FIGURE 6. Circuit closing switch 32 actuated manually upon depression of button 34 is adapted to complete the electrical connection between said bulb and battery to thus cause the emission of a light-beam from end 36 of the gun barrel, said light-beam being simulative of a laser beam for the purpose of the present game apparatus.

Pylon tower 38, which is removably connected at the lower end 40 thereof and by means of dowels 42 to gameboard 8, extends upwardly of the latter and substantially centrally thereof, the precise position of said tower with respect to the board being within the purview of selection and not intended as critical with respect to the present disclosure. Tubular sleeve 44 is swivelly secured to the upper end 46 of said pylon tower by means of knuckle joint 48, tubular member 50 being received within said tubular sleeve 44 and slidable therewithin as indicated by arrow 52 shown in FIGURE 3 of the drawings. As particularly shown in FIGURE 3 and also in FIGURE 2, the swivel connection between sleeve 44 and the upper end 46 of the pylon tower permits tubular member 50 to assume varied angles of inclination and direction,

thereby rendering model airplane 2 maneuverable when manually guided as below described.

The model airplane which is shown enlarged and schematically in FIGURE 4 will be seen to include electro-magnets 54, 56 therewithin and dart-bombs 6, 6 which are electro-magnetically held by magnets 54 and 56, respectively, by dint of the energization of the latter, said bombs being constructed of ferrous metal or other suitable magnetic material. Also included within the airplane fuselage 62 is electrically operated motor 64, propeller 66 being drivingly connected thereto by intermediary shaft 68. It will be understood that the motion of the model airplane is not dependent upon the rotation of the propeller but rather upon the manual activation of tubular member 50 by the player "flying" the airplane.

Handle 70 as shown in FIGURES 1-3 is integral with end 72 of the tubular member and contains circuit closing switches 74 and 76 therewithin as illustrated in the schematic illustration provided in FIGURE 4 of the drawings. Said switches 74 and 76 which are manually actuatable from positions externally of said handle, respectively permit control of the propeller 66 and of the release of bombs 6, 6. That is, as wired in the diagram according to FIGURE 4, the propeller driving motor 64 will be energized upon depression of switch 74 and the de-energization of electro-magnets 54 and 56 will be accomplished upon release of switch 76, the latter being depressed for retention of said bombs by the electro-magnets.

Battery casing 78 which contains batteries 80, 82, is attached to said tubular member 50 adjacently of handle 70 as shown in FIGURES 1-4, said batteries being the power source utilized for actuating said propeller and electro-magnets as aforedescribed.

FIGURE 5 indicates bay opening 84 within fuselage 62 through which the bombs 6, 6 are adapted to fall upon de-energization of said electro-magnets.

As shown in FIGURE 3, model airplane 2 is flexibly suspended at end 86 of said tubular member by link chain 88, wires 90 entering said airplane being grouped adjacently of said link chain as illustrated and extending through said tubular member to said battery casing 78 and switches 74, 76 to provide the electrical circuit as above described.

Accordingly, it will be appreciated that while one player guides the model airplane into position to impart the desired trajectory 92 to bombs 6, the other player will attempt to strike reflecting surface 94 provided on the airplane with the light-beam emitted from the gun barrel 18. Should the light-beam strike said surface prior to a predetermined portion of target area 4 being "hit," the player "manning" the anti-aircraft laser gun will win the battle. In the event a bomb finds its mark first, the bombing plane "flying" player is the victor.

Although the preferred embodiment of the bombing game apparatus has been described, it will be understood that within the purview of this invention various changes may be made in the forms, details, proportion and arrangement of parts, the combination thereof and mode of operation, which generally stated consists in a device capable of carrying out the objects set forth as disclosed and defined in the appended claims.

What is claimed is:

1. A bombing game apparatus, comprising a substantially rectangular board having a removably superposed target area positioned surfacedly thereof, a groove provided in said board and disposed peripherally of said target area, a battery housing having top and bottom walls, a battery within said housing, a tubular light-beam-emitting gun swivelly mounted upon the top wall of said housing, a tongue formed integrally with said bottom wall, said tongue being slidably securable within said groove, a pylon tower removably connected at one end thereof to said board, said tower extending upwardly of the latter and substantially centrally thereof, a tubular sleeve

swivelly secured to the other end of said pylon tower, a tubular member slidably received within said tubular sleeve, a model airplane flexibly suspended from one end of said tubular member, said airplane including at least one electromagnet therewithin and at least one simulated bomb releasably attached thereto, an electrically operated motor and a propeller drivingly connected to said motor, handle means integral with the other end of said tubular member, switch means within said handle means, a battery casing attached to said tubular member adjacently of said handle means, a battery within said casing, said battery, said at least one electro-magnet, said motor and said switch means being electrically connected, said switch means being manually actuatable externally of said handle means, said gun being manually movable within said groove and the light-beam-emitting gun being directable at said airplane.

2. A bombing game apparatus, comprising a substantially rectangular board having a removably superposed target area positioned surfacedly thereof, a groove provided in said board and disposed peripherally of said target area, a battery housing having top and bottom walls, a battery within said housing, a tubular gun barrel swivelly mounted upon the top wall of said housing, an electrical bulb mounted within said gun barrel, said battery and bulb being electrically connectable whereby said gun barrel will emit a light-beam when the battery and bulb are connected, a tongue formed integrally with said bottom wall, said tongue being slidably securable within said groove, a pylon tower removably connected at one end thereof to said board, said tower extending upwardly of the latter and substantially centrally thereof, a tubular sleeve swivelly secured to the other end of said pylon tower, a tubular member slidably received within said tubular sleeve, a model airplane flexibly suspended from one end of said tubular member, said airplane including at least one electro-magnet therewithin and at least one simulated bomb releasably attached thereto, handle means integral with the other end of said tubular member, switch means within said handle means, a battery casing attached to said tubular member adjacently of said handle means, a battery within said casing, said battery, said switch means and said at least one electro-magnet being electrically connected, said switch means being manually actuatable externally of said handle means, said battery housing being manually movable within said groove and the light-beam emitted from the gun barrel being directable at said airplane, and reflecting means disposed surfacedly of said airplane, said deflecting means being adapted to reflect the light-beam when the latter falls upon the former.

3. A bombing game apparatus, comprising a board having a target area positioned surfacedly thereof, a groove provided in said board and disposed peripherally of said target area, a housing having top and bottom walls, a gun barrel swivelly mounted upon the top wall of said housing, a tongue extending integrally of said bottom wall, said tongue being slidably securable within said groove, a pylon tower removably connected at one end thereof to said board, said tower extending upwardly of the latter, a tubular sleeve swivelly secured to the other end of said pylon tower, a tubular member slidably receivable within said tubular sleeve, a model airplane flexibly suspended from one end of said tubular member, electrically operable means on said model airplane for releasably supporting a simulated bomb, handle means integral with the other end of said tubular member and switch means within handle means, said switch means being manually actuatable externally of said handle means, said switch means being included in a circuit for controlling said supporting means and operable to release a simulated bomb carried by said model airplane, said housing being manually movable within said groove and said gun barrel being directable at said airplane.

4. A bombing game apparatus, comprising a board

5

having a target area provided surfacedly thereof, a pylon tower removably supported at one end thereof upon said board, said tower extending upwardly of the latter and above the target area thereof, a tubular sleeve swivelly secured to the other end of said pylon tower, a tubular member slidably received within said tubular sleeve, a model airplane flexibly suspended from one end of said tubular member, said airplane including at least one electro-magnet therewithin and at least one simulated bomb releasably attached thereto, handle means integral with the other end of said tubular member, switch means within said handle means, a battery casing, a battery within said casing, said battery, said switch means and said at least one electro-magnet being electrically connected, and said switch means being manually actuatable externally of said handle means, whereby said at least one simulated bomb will be permitted to fall upon said target

6

area when said switch means is actuated to de-energize said at least one electro-magnet.

References Cited by the Examiner

UNITED STATES PATENTS

1,348,283	8/20	Koehl.	
2,280,623	4/42	Broomfield.	
2,562,648	7/51	Sparrow	----- 273—101.1
3,083,019	3/63	Giuliano.	

FOREIGN PATENTS

252,791	10/48	Switzerland.
998,125	9/51	France.
1,266,389	5/61	France.

DELBERT B. LOWE, *Primary Examiner.*