

(19) World Intellectual Property  
Organization  
International Bureau



(43) International Publication Date  
12 August 2004 (12.08.2004)

PCT

(10) International Publication Number  
**WO 2004/067372 A1**

- (51) International Patent Classification<sup>7</sup>: **B63B 21/50**
- (21) International Application Number: PCT/NO2004/000021
- (22) International Filing Date: 26 January 2004 (26.01.2004)
- (25) Filing Language: English
- (26) Publication Language: English
- (30) Priority Data: 20030424 27 January 2003 (27.01.2003) NO
- (71) Applicant (for all designated States except US): **MOSS MARITIME AS** [NO/NO]; P.O. Box 120, N-1325 Lysaker (NO).
- (72) Inventors; and
- (75) Inventors/Applicants (for US only): **KRISTENSEN, Per, Herbert** [NO/NO]; Mallingsrudveien 28, N-1349 Rykkin (NO). **PETTERSEN, Erik** [NO/NO]; Grindene 3, N-3408 Tranby (NO).
- (74) Agent: **ONSAGERS AS**; P.O. Box 6963 St. Olavs plass, N-0130 OSLO (NO).
- (81) Designated States (unless otherwise indicated, for every kind of national protection available): AE, AG, AL, AM, AT, AU, AZ, BA, BB, BG, BR, BW, BY, BZ, CA, CH, CN, CO, CR, CU, CZ, DE, DK, DM, DZ, EC, EE, EG, ES, FI, GB, GD, GE, GH, GM, HR, HU, ID, IL, IN, IS, JP, KE, KG, KP, KR, KZ, LC, LK, LR, LS, LT, LU, LV, MA, MD, MG, MK, MN, MW, MX, MZ, NA, NI, NO, NZ, OM, PG, PH, PL, PT, RO, RU, SC, SD, SE, SG, SK, SL, SY, TJ, TM, TN, TR, TT, TZ, UA, UG, US, UZ, VC, VN, YU, ZA, ZM, ZW.
- (84) Designated States (unless otherwise indicated, for every kind of regional protection available): ARIPO (BW, GH, GM, KE, LS, MW, MZ, SD, SL, SZ, TZ, UG, ZM, ZW), Eurasian (AM, AZ, BY, KG, KZ, MD, RU, TJ, TM), European (AT, BE, BG, CH, CY, CZ, DE, DK, EE, ES, FI, FR, GB, GR, HU, IE, IT, LU, MC, NL, PT, RO, SE, SI, SK, TR), OAPI (BF, BJ, CF, CG, CI, CM, GA, GN, GQ, GW, ML, MR, NE, SN, TD, TG).

[Continued on next page]

(54) Title: FLOATING STRUCTURE

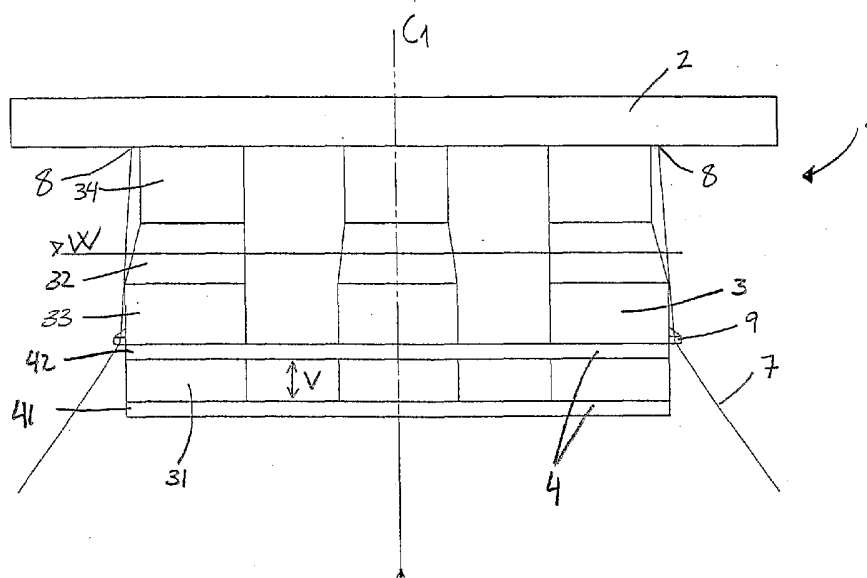

(57) Abstract: The invention relates to a floating structure 1, for instance a semi submersible platform, comprising a deck structure 2, vertical columns 3 and a pontoon structure 4. The floating structure 1 is moored to the seabed with anchor lines 7. The mooring of the floating structure is done with taut line anchoring system, where the vertical stiffness in the anchoring system is approximately 20% of the water plane stiffness for the floating structure. The invention also relates to a floating structure as described above where the pontoon structure 4 comprises at least two levels of pontoons and where the columns 3 are formed to give variable water plane stiffness.

WO 2004/067372 A1



**Published:**

— *with international search report*

*For two-letter codes and other abbreviations, refer to the "Guidance Notes on Codes and Abbreviations" appearing at the beginning of each regular issue of the PCT Gazette.*

## FLOATING STRUCTURE

The invention relates to a system for dampening the movement of a floating structure, for instance a semi submersible platform, where the floating platform comprises a deck structure, several columns which support the deck structure and penetrate the water plane surface and a pontoon structure and which floating structure is moored to the seabed.

There are several reasons why a floating structure should have as little movement or as reduced heave pitch and roll movement as possible. Especially for floating structures as semi submersible platforms or wellhead platforms are there a strong need to reduce the motion. A wellhead platform normally is understood to be a platform in an oil / gas offshore installation complex which accommodate the production risers of the production streams, preferably with dry wellheads and some process equipment for oil / gas treatment, but normally not full production package for treatment of the hydrocarbons to final export specifications. There will also be export risers, which can be hard risers, flexible risers or steel catenary risers (SCR), since there is limited storage capability in a semi submersible platform.

In order to accommodate dry wellheads, the motion characteristics of the unit must be favourable to reduce tensioner stroke requirements and extra loads on the risers. Traditionally, wellhead platforms have been jackets for small drafts of water and tension leg platforms (TLPs) for larger drafts. Jackets become unsuitable for drafts in excess of a couple of hundred meters. TLP platforms will be expensive and difficult to install for drafts in excess of about 1000 meters. Especially the tethers and the foundations of the TLPs are increasingly complex for the larger drafts.

An ordinary semi submersible platform will not possess the motion characteristics required to allow dry wellheads in most required environments. Such a platform must therefore get special characteristics to reduce the motions to a level that can be acceptable for dry wellhead and their riser tension compensators

There have been several attempts to reduce the motion characteristics of a floating structure as a semi submersible platform. Some of these techniques are mentioned below.

In US 4,829,928 and ocean platform has a negative buoyant pontoon suspended from the balance of the platform to increase the heave resonant period to at least 25 seconds. Tendons suspend the pontoon to a depth where dynamic wave forces do not materially act directly on it in seas of normally occurring periods of up to about 15 seconds. Columns and upper pontoon provide buoyancy for the platform.

EP 359 702 describes a semi submersible platform which includes a fully submerged lower hull and a plurality of stabilizing columns which extend from the lower hull to an upper hull. Each column has a dynamic wave zone in the design seaway. At least one column has means adapted to reduce its water plane area to

increase the natural heave period of the platform, so that the natural heave period becomes greater than the longest period of any wave with substantial energy in the design seaway, thereby lowering the platform's heave response. These means are a channel which in use becomes flooded with sea water.

5 US 6431 107 describes a floating offshore structure with a buoyant hull with sufficient fixed ballast to place the centre of gravity of the floating structure below the centre of buoyancy of the hull. A support structure coupled to an upper end of the hull supports and elevates a superstructure above the water surface. A soft tendon is attached between the hull and the seafloor.

10 This floating structure has as a consequence a very high natural period during heave, and due to very little restoring force it may have large second order heave motions. To reduce the second order heave motion the platform is provided with a vertical anchoring system with a vertical stiffness as large as possible but limited so that the resulting natural period during heave is at least 20 second.

15 To secure a tension within acceptable limits in the risers and secure the riser and other equipments between the platform and the seabed from damage, is there still with these solutions a necessity to have larger riser tension compensators on the deck structure of the floating structure. These tension compensators have generally a large weight and a method to reduce or eliminate the need for these compensators  
20 would give large benefits, since weights is a crucial factor when designing a floating structure and especially a platform structure with processing equipments topside.

The aim for the present invention is to achieve a floating structure which is moored to the seabed with reduced motion characteristics.

25 It is an aim to especially reduce the heave motion of the floating structure by tuning the natural period of the floating structure in with the cancellation period.

There is also an aim for the present invention to achieve a floating structure that has a favourable motion characteristic during a large range of external conditions, for instance different wavelengths of the waves or swells in the sea.

30 In addition there is an aim of achieving a floating structure for instance in the form of a semi submersible platform with favourable motion characteristics at the same time as the platform may have larger topside deck loads than the standard semi submersible platforms.

35 These aims are achieved with a floating structure according to the following independent claims.

In order to reduce the requirements to the riser tension compensators, it is primarily the heave motions that have to be reduced, but pitch/roll motions must also be within acceptable limits.

5 The present invention relates to a floating structure, for instance a semi submersible platform but it can also be another type of floating platform as a wellhead platform or a smaller process platform. The floating structure comprises a deck structure, mainly vertical columns supporting the deck structure and penetrating the water plane surface, and a pontoon structure. The deck structure may have several levels and there may on the deck be all kinds of equipment and connections point for  
10 risers, umbilicals, other lines running from the deck structure to the seabed or installations on the seabed. The floating structure is moored to the seabed, with anchor lines. These anchor lines may be more or less grouped or bundled on for instance four opposite sides of the floating structure or they may be more evenly distributed around the structure.

15 The mooring of the floating structure is done with a taut line anchoring system, where the vertical stiffness in the anchoring system is approximately 20% of the water plane stiffness for the floating structure, where the water plane stiffness is given by  $\rho g A_w$ , where  $\rho$  is the density of water,  $g$  the acceleration of gravity and  $A_w$  is the water plane area. This gives behaviour of the floating structure which is  
20 favourable especially in relation to an eventually need of tension compensators.

In one aspect of the inventions the anchoring system consists of several anchor lines, which may be steel wires and/or fibre ropes attached between the floating structure and anchors embedded in the seabed.

25 In addition gives the present invention a floating structure as mention above which has a favourable motion characteristic in all kinds of conditions by the combination of features regarding the mooring system, the pontoon structure and the configuration of the columns.

30 In this the pontoon structure comprises at least two levels of pontoons, a first and a second pontoon level, where the pontoon levels is arranged in the vicinity of a bottom part of the vertical columns, the one above the other in the mainly vertical direction, so that water is "trapped" between the two pontoons to give added mass to the floating structure.

35 The mooring of the floating structure is done as described above, with a taut line anchoring system, where the vertical stiffness in the anchoring system is approximately 20% of the water plane stiffness for the floating structure, where the water plane stiffness is given by  $\rho g A_w$ , where  $\rho$  is the density of water,  $g$  the acceleration of gravity and  $A_w$  is the water plane area.

As the last feature in the combination the columns are formed to give a variable water plane stiffness, where at least one of the columns have a part penetrating the water plane surface with variable cross section in the vertical direction.

5 In another aspect of the inventions the section of at least one of the columns penetrating the water plane surface, has a conical shape in the longitudinal direction of the column with the smaller diameter closest to the deck structure. The tapered section has an inclined centreline, where the centreline converges upwards towards a vertical centreline for the floating structure.

10 For the floating structure the mainly vertical distance between the different pontoon levels is a function of the overlapping area between two neighbouring levels in another aspect of the invention. The different pontoon levels may consist of only one pontoon and that the pontoon is partly symmetrical about a centre axis of the floating structure and has a through going central opening. The pontoons in the different levels may be substantially equal in form. The above mentioned mainly  
15 vertical distance between the pontoon levels may be in the range of 25 to 40 percent of the horizontal distance between an outermost and an innermost point of the overlapping area between two neighbouring pontoons in a radial direction from the centreline of the floating structure.

20 The theoretical background for the present invention of a floating structure with the favourable motion characteristic, for instance for the case where there for normal semi submersibles, would be a need for using large riser tension compensators, is as follows.

25 The heave motion characteristics for a floating object is normally described by Response Amplitude Operators (RAO's), also called transfer functions. A typical RAO for a semi submersible platform is shown in figure 3. In the figure the regular wave periods is used as abscissa and the response amplitude pr. m wave amplitude as ordinate. It should be remembered that the RAO is most correctly described by complex numbers, i.e. in addition to the amplitude, also phase angles must be provided.

30 Such a RAO has some special features. The region pointed out by arrow A is called the cancellation region. The peak below arrow B is the natural period. To the right of the natural period in the figure, it is the water plane stiffness that mostly governs the motions, and the RAO will asymptotically approach 1.0 for long waves, i.e. the unit will "ride the waves".

35 To the left of the natural period in the figure, the total mass and hydrodynamic excitation forces will be governing for the motions. The cancellation region is caused by the fact that the hydrodynamic excitation forces, with their origin from water particle accelerations and the dynamic pressure under the columns, tend to

cancel each other out at this period. This is a very attractive feature for a semi submersible platform, and is a major reason for the favourable motion characteristics of such a platform.

5 The peak caused by the natural period is, however, a problem in long waves. If there is wave excitation energy in this region, excessive heave motions may be the result. Tuning of the platform to a very long heave natural period could help the problem, but will also worsen the motions in normal and shorter waves. Excessive motions in long waves could be very hampering for a wellhead platform, where the tension compensators could exceed their design stroke and damage the risers. In  
10 some regions, where use of such wellhead platforms is in use (e.g. West of Africa) swells with extra long periods occur and can cause problems if the response is not reduced.

There are several strategies for reducing the effect of the natural period of the heave.

15 The present invention gives a solution of how to tune the natural period to the cancellation period. It can be shown mathematically that the natural period will always exist at longer periods than the cancellation period for a free floating object. These two periods can therefore not be tuned without external stiffness contribution.

20 The invention is to provide this external extra stiffness by means of the mooring system of the unit.

By using a taut wire system, there will be a significant vertical stiffness in addition to the horizontal mooring stiffness. Since a taut wire system has no line element resting on the bottom and the catenary effect is small, it is the elastic stiffness of the lines that compose the vertical stiffness.

25 It has been found that if the mooring system has a vertical stiffness corresponding to about 20% of the water plane stiffness, the natural period correspond to the cancellation period. The water plane stiffness is defined as  $\rho g A_w$ , where:

$A_w$  is the water plane area

$P$  is the density of water and

30  $g$  is the acceleration of gravity.

Analysing the invented platform with hydrodynamic programs has confirmed this. One analysis is carried out by means of the program AQWA-LINE. This is a linear sink-source program for frequency domain analysis. The other program is AQWA-NAUT. This is a program using the hydrodynamic coefficients from the sink-source  
35 solution, but calculates real (non-linear) restoring. The program operates in the time domain, where the coefficients are mapped from frequency to time domain.

The results from both analyses are shown in Figure 4. As shown, the natural period has been eliminated by the cancellation in both analyses. The resulting heave motion when exposed to waves with long periods will not be adversely affected by the heave natural period any longer. This platform can consequently be used in  
5 regions where long periodic waves (swells) exist.

In order to achieve a floating structure which have a favourable motion characteristic in all kinds of conditions with respect of heave, pitch and roll it is a necessity to combine the above mentioned feature with other features for the floating structure.

10 The design should be such that the natural period is at higher wave periods than the wave excitation spectrum. Since the natural period is a function of the total mass and the water plane stiffness, this can be achieved by increasing the mass and reducing the water plane stiffness as much as permissible. In the present invention, this has been achieved by entrapping a large amount of water between the several  
15 levels of pontoons, favourable two levels of pontoons. This gives a larger added mass than normally achieved by ordinary (small draft) semi submersible platforms.

The magnitude of the natural period peak is dependent on the damping of the structure at the natural period. In the present invention, the structure with several levels of pontoons, create a large viscous damping due to a large surface and the  
20 water flow in the split between the pontoons. This also gives the possibility of having a larger load on the superstructure of the platform.

Disturbing the uniquely defined natural period by having variable water plane stiffness can also reduce the magnitude of the natural period. The natural period will therefore not have a constant value but will depend on the motion amplitude. It  
25 is a well-known fact that such non-linearity in stiffness will reduce the response amplitude. This solution is described in the applicants own application PCT/NO02/00228, where design does consequently have a conical section in the water plane area to provide this non-linearity. This design will also reduce parametric couplings between heave and pitch/roll motions.

30 By combining the three different features for a floating structure, one achieves a floating structure which has a superior motion characteristic for all kinds of conditions. These features complement each other in an unexpected way and give a favourable platform construction which is simple and have the benefit of being able to have not only an addend mass on the deck structure but at the same time being  
35 within the desired motion characteristics with respect to heave, pitch roll so that it is especially suitable as a well head platform with dry wellheads. This means one can produce a relatively compact and small platform whit a lot more functionality than a normal semi submersible platform, and thereby achieve cost benefits.

In the following the invention will be explained with reference to the following drawings where:

Fig. 1 is a side view of a floating structure, a semi submersible platform according to the present invention,

5 Fig. 2 shows a principal sketch of the platform in figure 1 seen from above,

Fig. 3 a diagram showing the typical heave transfer function (RAO) for a semi submersible platform,

Fig. 4 is a diagram showing the cancellation of the heave natural period for a semi submersible platform in accordance with the invention,

10 Fig. 5 shows a second embodiment of the semi submersible platform shown in fig. 1.

Figure 1 shows a floating structure 1 according to the invention. The floating structure 1 is in this case a semi-submersible platform. The platform comprises

15 a deck structure 2. Four vertical columns 3 support the deck structure 2. The columns 3 run from the deck structure 2, penetrate the water plane surface W and are in the bottom part 31 connected to a pontoon structure 4. The pontoon structure 4 is mainly horizontal. The floating structure 1 is moored to the seabed with anchor lines 7. The anchor lines 7 run from the connection point 8 to the floating structure 1, which in this case is on the deck structure 2, toward the seabed through anchor  
20 line guides 9.

The mooring of the floating structure 1 is done with taut line anchoring system, where the vertical stiffness in the anchoring system is approximately 20% of the water plane stiffness for the floating structure. The vertical stiffness in the anchoring system can be achieved in several ways and it will be up to a person  
25 skilled in the art to choose the most suitable way.

The columns 3 of the floating structure 1 are mainly vertical, and have a cylindrical shape in the vertical direction. The columns 3 are positioned symmetrical about a centre axis C1 of the floating structure 1. The columns 3 have a first cylindrical section 33 with a diameter D1, which section comprises the bottom part 31 to which  
30 the pontoon structure 4 is connected. Above the first cylindrical section 33 there is a section 32 which penetrates the water surface W during wave motions. This section 32 is tapered from a diameter D1 equal to the diameter for the first cylindrical section 33 to a second diameter D2 which is smaller than the first diameter D1. The centre line for the tapered section 32 of the columns 3 is inclined so that it  
35 converges upwards with the centreline C1 of the floating structures. The columns continue vertically upwards with a second cylindrical section 34 with a mainly

vertical centreline and with a diameter equal to the second diameter D2. The second cylindrical section supports the deck structure 2 of the semi submersible platform.

The semi submersible platform will naturally have risers, and in other cases umbilicals, drill strings etc, which are not shown in the figures running from the seabed or the well or other submerged installation to the top of deck structure 2 through a moon pool 21. The moon pool 21 is shown schematically in fig. 2, but risers etc. are not shown in the figures to make the figures more clear. The deck structure will also have other equipment necessary for performing the desired processes on the deck structure and exit risers to other offshore facilities.

10 The pontoon structure 4 of the platform 1 consist in this embodiment of the invention of a two level structure, with a first pontoon level 41 and a second pontoon level 42. In this embodiment the two pontoon levels 41 and 42 respectively, are equal and each level provide an octagonal ring shaped unitary  
15 pontoon, symmetrical about the centreline C1 of the floating structure 1. The width of the ring shaped pontoon is determined by the difference between the distance H2 from the centreline of the floating structure to the outer perimeter of a section part of the octagonal shaped pontoon and the distance H1 from the centreline to the inner perimeter of the same section part. The different pontoon levels 41 and 42 are  
20 advantageous, but other designs may be favourable, dependent of the circumferential parameters and the use of the floating structure.

As shown in the second embodiment in fig. 5 there may be trusses 5 between the different pontoon levels 41, 42 respectively, in the pontoon structure 4.

## CLAIMS

1. Floating structure (1) for instance a semi submersible platform, comprising a deck structure (2), mainly vertical columns (3) supporting the deck structure (2) and penetrating the water plane surface, and a pontoon structure, where the floating  
5 (1) structure is moored to the seabed,  
characterised in that  
the mooring of the floating structure (1) is done with a taut line anchoring system,  
where the vertical stiffness in the anchoring system is approximately 20% of the  
waterplane stiffness for the floating structure (1), where the waterplane stiffness is  
10 given by  $\rho g A_w$ , where  $\rho$  is the density of water,  $g$  the acceleration of gravity and  
 $A_w$  is the waterplane area.
2. Floating structure according to claim 1, characterised in that  
the anchoring system consists of several anchor lines (7), which may be steel wires  
15 and/or fibre ropes attached between the floating structure (1) and anchors embedded  
in the seabed.
3. Floating structure according to one of the preceding claims, characterised in  
that  
20 at least one of the columns (3) has a section (32) penetrating the waterplane surface  
with variable cross section in the mainly vertical direction, so that the floating  
structure (1) has variable waterplane stiffness.
4. Floating structure according to claim 3, characterised in that  
25 the section (32) of the column (3) penetrating the water plane surface, has a conical  
shape in the longitudinal direction of the column (3) with the smaller diameter  
closest to the deck structure (2) and with an inclined centreline, where the centreline  
converge upwards towards a vertical centreline (C1) for the floating structure (1).
- 30 5. Floating structure according to one of the preceding claims, characterised in  
that  
the pontoon structure (4) comprises at least two levels of pontoons, a first and a  
second pontoon level (41, 42 respectively), where the pontoon levels is arranged in  
the vicinity of a bottom part (31) of the vertical columns (3), the one above the  
35 other in the mainly vertical direction, so that water is "trapped" between the two  
pontoons to give added mass to the floating structure (1).
6. Floating structure according to claim 5, characterised in that  
the mainly vertical distance (V) between the different pontoon levels (41, 42) is a  
40 function of the overlapping area between two neighbouring levels.

7. Floating structure according to claim 5 or 6, characterised in that each of the different pontoon levels (41, 42) consist of one unitary pontoon for each level and that the pontoon for each level is partly symmetrical about a centre axis (C1) of the floating structure and has a through going central opening (6).
- 5
8. Floating structure according to one of the claims 5-7, characterised in that the pontoons in the different levels are substantially equal in form.
9. Floating structure according to claim 7 and 8, characterised in that
- 10 the mainly vertical distance (V) between the pontoon levels is in the range of 25 to 40 percent of the horizontal distance (H1, H2) between an outermost and an innermost point of the overlapping area between two neighbouring pontoons in a radial direction from the centreline (C1) of the floating structure.
- 15 10. Floating structure (1), for instance a semi submersible platform, comprising a deck structure (2), vertical columns (3) supporting the deck structure (2) and penetrating the water plane surface, and a pontoon structure (4), where the floating structure (1) is moored to the seabed with anchor lines (7), characterised in the combination of that
- 20 - the pontoon structure (4) comprises at least two levels of pontoons, a first and a second pontoon level, where the pontoon levels is arranged in the vicinity of a bottom part of the vertical columns, the one above the other in the mainly vertical direction, so that water is "trapped" between the two pontoons to give added mass to the floating structure,
- 25 - the mooring of the floating structure is done with taut line anchoring system, where the vertical stiffness in the anchoring system is approximately 20% of the water plane stiffness for the floating structure, where the water plane stiffness is given by  $\rho g A_w$ , where  $\rho$  is the density of water,  $g$  the acceleration of gravity and  $A_w$  is the water plane area,
- 30 - the columns are formed to give a variable water plane stiffness, where at least one of the columns have a section (32) penetrating the water plane surface with variable cross section in the vertical direction.

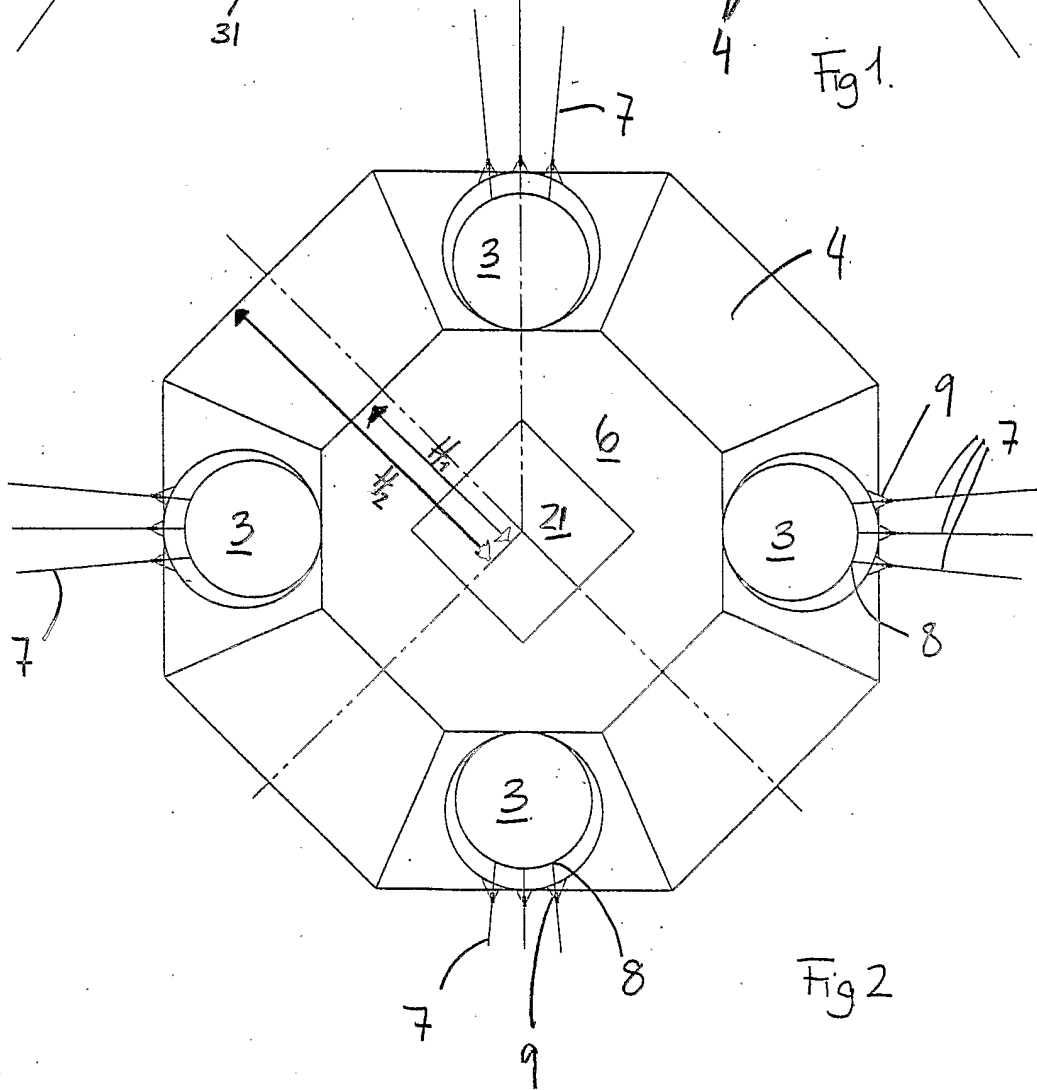
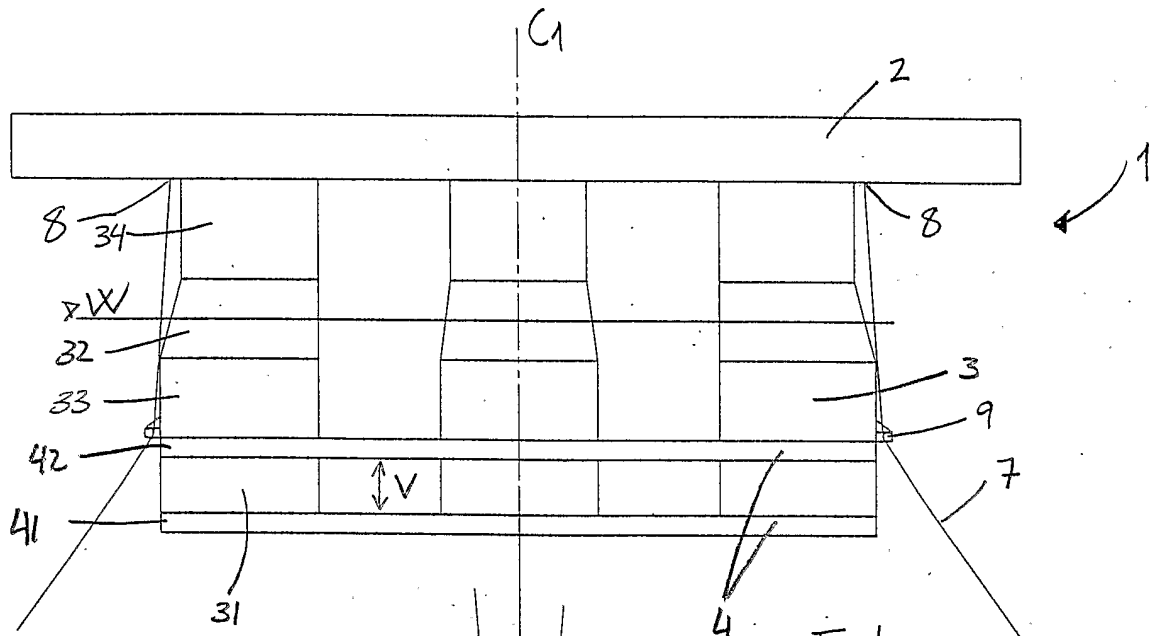

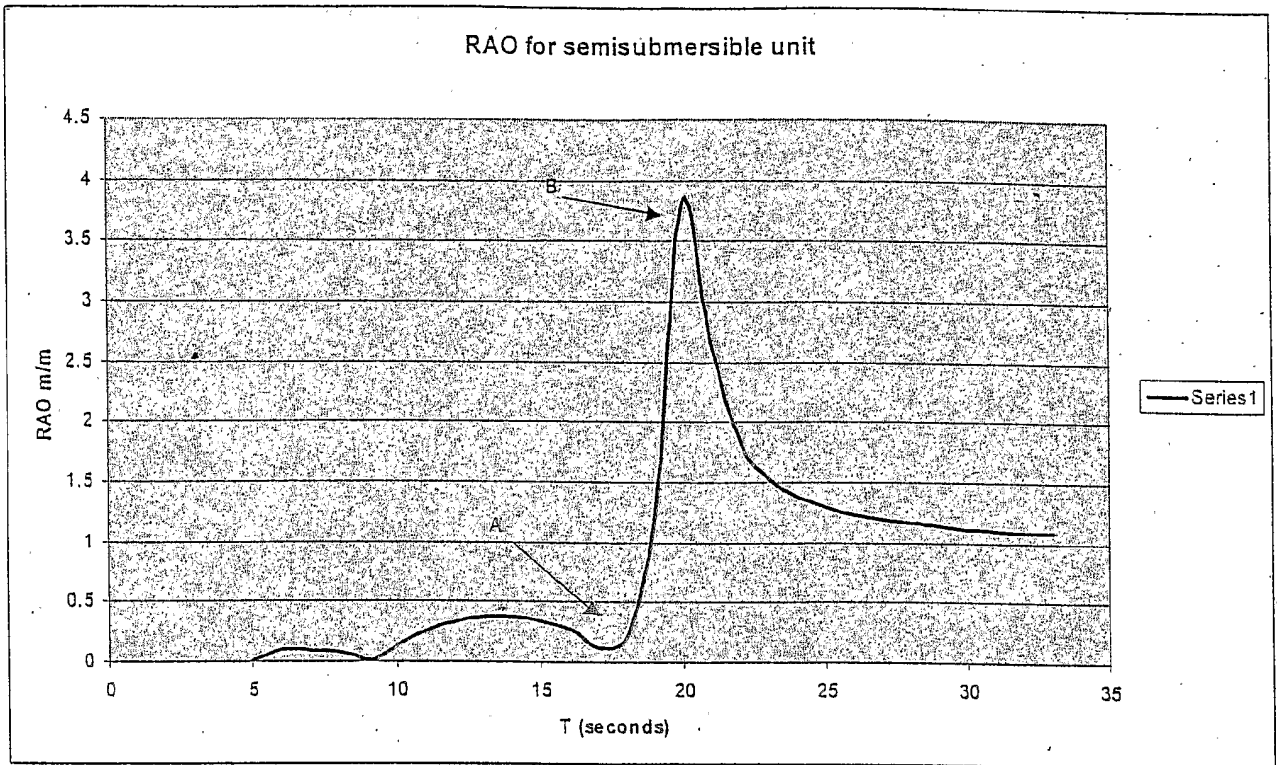

Fig 3

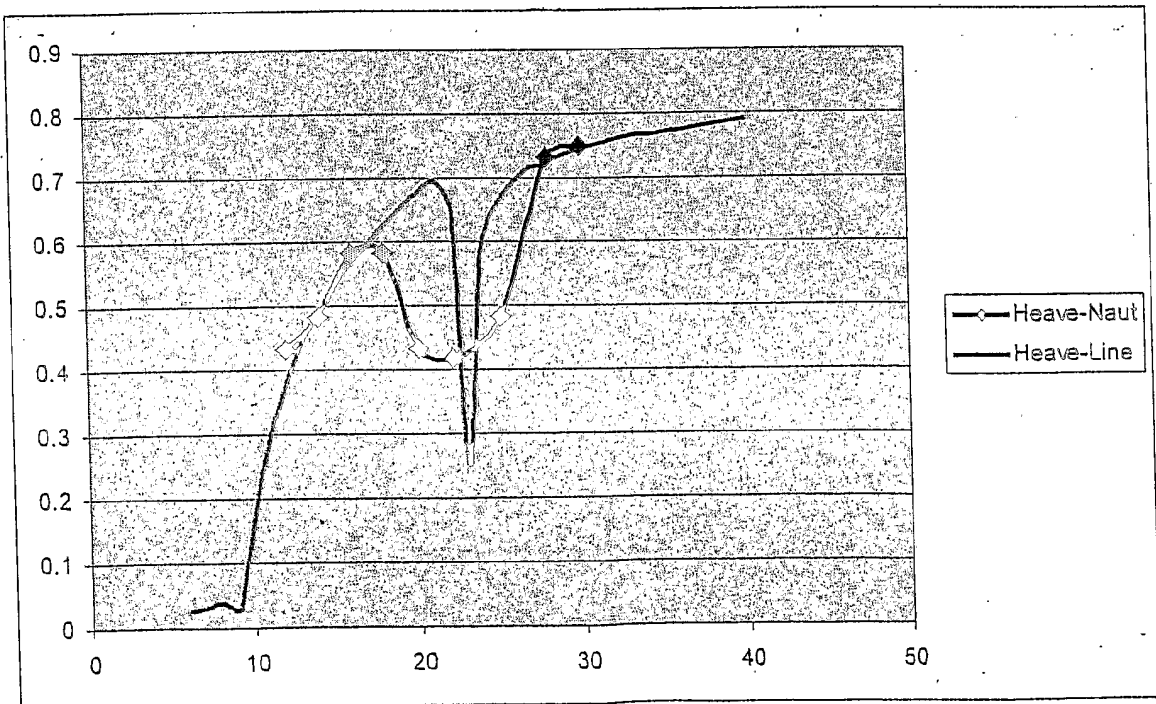
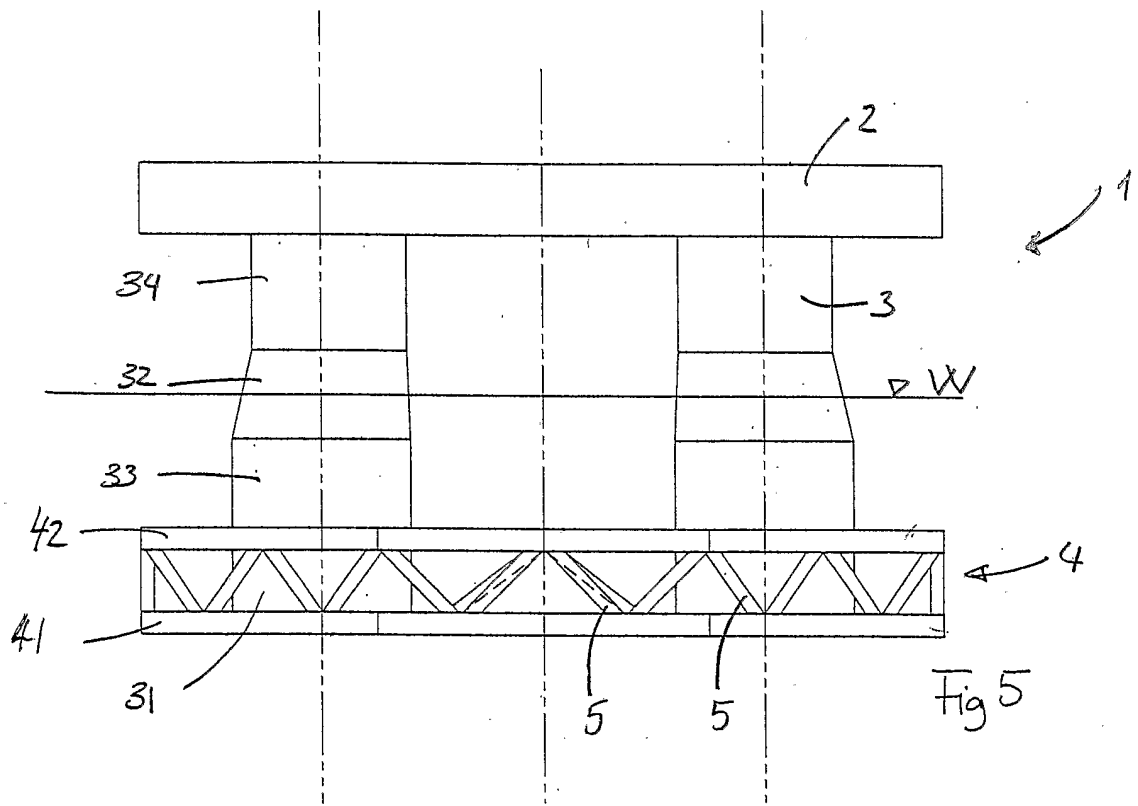

Fig 4



# INTERNATIONAL SEARCH REPORT

International Application No  
PCT/NO2004/000021

**A. CLASSIFICATION OF SUBJECT MATTER**  
IPC 7 B63B21/50

According to International Patent Classification (IPC) or to both national classification and IPC

**B. FIELDS SEARCHED**

Minimum documentation searched (classification system followed by classification symbols)  
IPC 7 B63B

Documentation searched other than minimum documentation to the extent that such documents are included in the fields searched

Electronic data base consulted during the international search (name of data base and, where practical, search terms used)

EPO-Internal

**C. DOCUMENTS CONSIDERED TO BE RELEVANT**

Category °	Citation of document, with indication, where appropriate, of the relevant passages	Relevant to claim No.
A	EP 0 357 269 A (CONOCO INC) 7 March 1990 (1990-03-07) column 6, line 34 -column 7, line 10; figures 1,2	1,2
A	EP 0 359 702 A (ODECO INC) 21 March 1990 (1990-03-21) cited in the application the whole document	1,2
A	US 6 273 018 B1 (PIERMATTEI EARL J ET AL) 14 August 2001 (2001-08-14) figures 1-4	3

Further documents are listed in the continuation of box C.

Patent family members are listed in annex.

° Special categories of cited documents :

- \*A\* document defining the general state of the art which is not considered to be of particular relevance
- \*E\* earlier document but published on or after the international filing date
- \*L\* document which may throw doubts on priority claim(s) or which is cited to establish the publication date of another citation or other special reason (as specified)
- \*O\* document referring to an oral disclosure, use, exhibition or other means
- \*P\* document published prior to the international filing date but later than the priority date claimed

- \*T\* later document published after the international filing date or priority date and not in conflict with the application but cited to understand the principle or theory underlying the invention
- \*X\* document of particular relevance; the claimed invention cannot be considered novel or cannot be considered to involve an inventive step when the document is taken alone
- \*Y\* document of particular relevance; the claimed invention cannot be considered to involve an inventive step when the document is combined with one or more other such documents, such combination being obvious to a person skilled in the art.
- \*&\* document member of the same patent family

Date of the actual completion of the international search

17 May 2004

Date of mailing of the international search report

25/05/2004

Name and mailing address of the ISA

European Patent Office, P.B. 5818 Patentlaan 2  
NL - 2280 HV Rijswijk  
Tel. (+31-70) 340-2040. Tx. 31 651 epo nl,  
Fax: (+31-70) 340-3016

Authorized officer

DE SENA HERNAND... , A

# INTERNATIONAL SEARCH REPORT

Information on patent family members

International Application No PCT/N02004/000021
---

Patent document cited in search report	Publication date	Publication date	Patent family member(s)	Publication date
EP 0357269	A	07-03-1990	US 4938630 A	03-07-1990
			BR 8904137 A	10-04-1990
			DK 409889 A	23-02-1990
			EP 0357269 A1	07-03-1990
			JP 2106488 A	18-04-1990
			NO 893036 A	23-02-1990
EP 0359702	A	21-03-1990	US 4850744 A	25-07-1989
			BR 8904384 A	24-04-1990
			EP 0359702 A1	21-03-1990
			NO 893066 A	05-03-1990
US 6273018	B1	14-08-2001	AU 746242 B2	18-04-2002
			AU 8816698 A	16-03-1999
			WO 9910230 A1	04-03-1999
			GB 2328408 A ,B	24-02-1999
			GB 2337964 A ,B	08-12-1999