

(19)
(12)

(KR)
(B1)

(51) 。 Int. Cl. ⁷
H01L 21/60

(45)
(11)
(24)

2003 03 26
10 - 0377472
2003 03 12

(21) 10 - 1999 - 0056409
(22) 1999 12 10

(65) 2001 - 0055255
(43) 2001 07 04

(73) 957

(72) 가 2 335 - 13
465 - 7
110 - 3
221 - 82302

(74)
:

(54)

, CCD

가

가

2a

1

2a 2c 1,2,3

3a 3g 1

100,101,103;

2; 2a;

10; 11;

12; 13;

14; 15;

16; 17;

18; 20;

21; 30;

50;

CCD

CCD Charge Coupled Devices

3

가

MOS

CCD

MOS

(LSI)

. CCD

가

가

1,500 ,

512 x 320

CCD 가

CCD
가

(100') 1

(2a)가

CCD

(2)

CCD

(2)

(10)

(10)

(11)

(2)

(15)

(15)

(2)

(10)

(15)

(12)

(14)

(10)

(13)가

(13)

(2)

(2a)

(10)

(12)

(20)

(10)

(15)

(2)

(2)

(20)

(30)가

(14)

(100')

(13)

(2)

가

(20),

가 가

가

가

' , ' , .
 , 가
 .
 ,
 가 .
 가 , ,
 ; , ;
 가 ;
 ;
 ;
 , , , .
 , 가
 , .
 ,
 , 가
 .

가 가

2a	2c	1,2,3	(100,101,102)	.
2a	(2)	(100)	(2a)가	(2)
(10)	(11)	(10)	(15)	(11)
	(13)		(12)	(14)
			(2)	(11)
	(15)		(12)	(13)
				(18)

42 , , (12) (13) (Cu) (Alloy)

(12) (Ag) , (13) (30) (2) (2a)
(Au), (Ag), (Ni) (Pd)

(10) (11)
(circuit tape), (circuit film)

(10) (15) (50)가 (15) (50)
(2) (50) (2)

(2) (2a) (10) (12)
(30)

(21) (10) (12) (2)
(20)가 (21)

(21) (2) (2a) (12)
(20)가

(10) (13) 가 가
(17)

2b (101) 2a (10) (15) (16)가

, 2 (11) (12) (11) (12) (
11) (12) (16)

(16)가 (21)

, 2c (102) 2a (12)가 (10) (15) (21)
(2) (2a) (10) 2c

(102) 2b

3a 3g 1 (100)

(11) (2) (15)가
(11) (12) (13) (10)

(14)

, (12) (13) (18) ,
 (10) .

, (15) (16)가 (15) (12)가 (10)
 (10) (50) (15) .(3a)
) (50) , ,

, (10) (15) (50) (2a)가 (2)
 .(3b)

가 (50) (2)

, (2) (2a) (10) (12)
 (30) .(3c)

12) , (10) (15) (12)가 ()
 (2) (2a) .

.(3d) (10) (12) (21)
 (21) .

, (21) (20) (2)
 (2) .(3e) ,

(3f) (10) (13) (17) .

가 가 .

가

가 가 .

(57)

1.

가 ;

가

, ;

, ,

;

;

,

;

2.

1

,

,

,

3.

1

,

가

.

4.

1

,

,

,

,

5.

1

,

가

.

6.

가

,

,

,

,

;

가

;

;

;

;

7.

6 ,

8.

6 ,

가

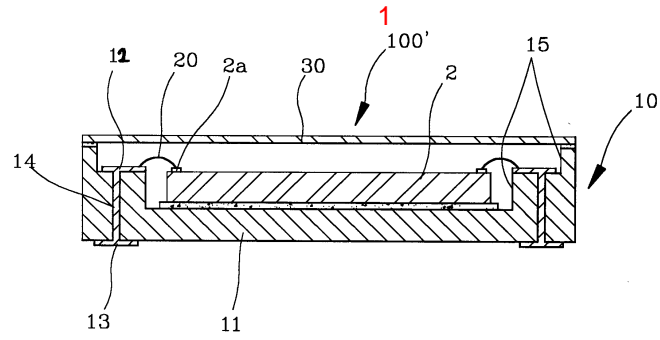

2a

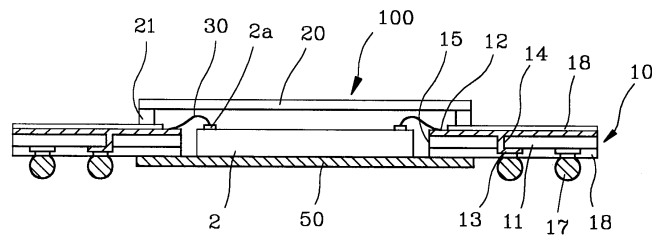

2b

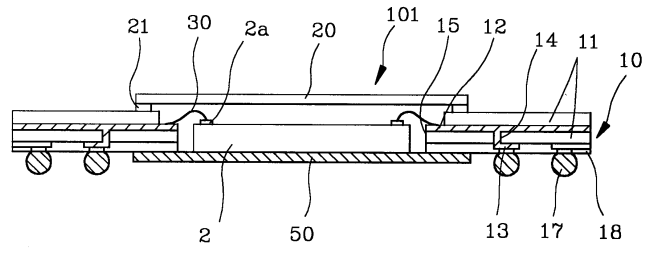

2c

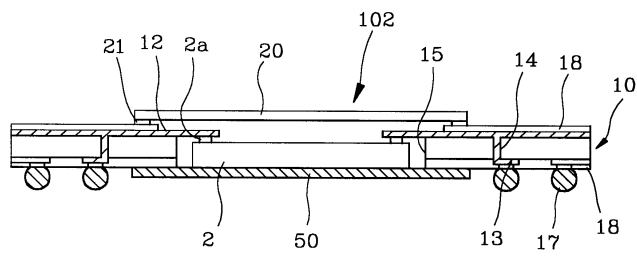

3a

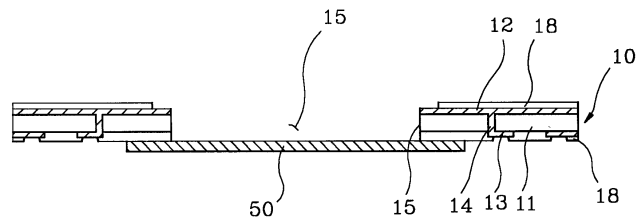

3b

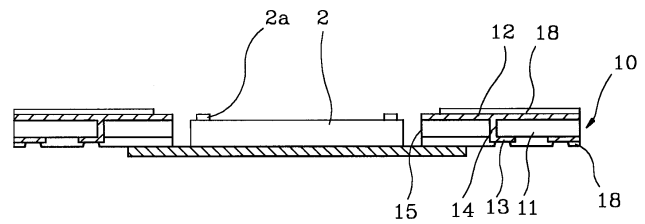

3c

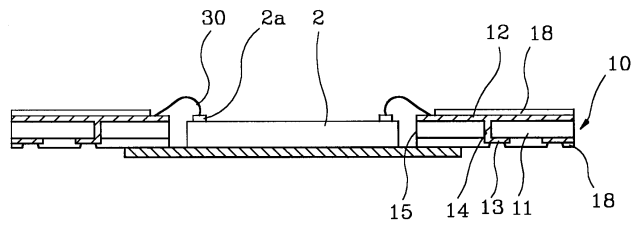

3d

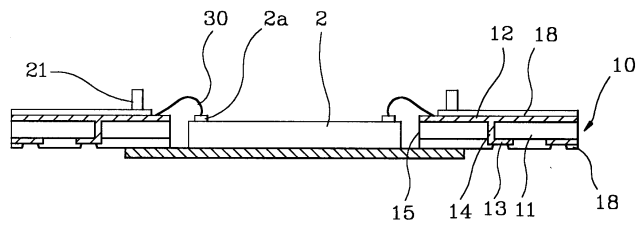

3e

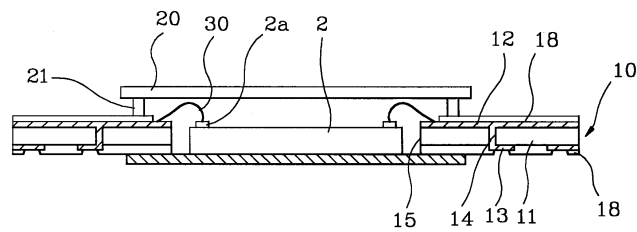

3f

