

L. TREMMEL.
CELLAR WINDOW.

No. 523,137.

Patented July 17, 1894.

Fig. 1.

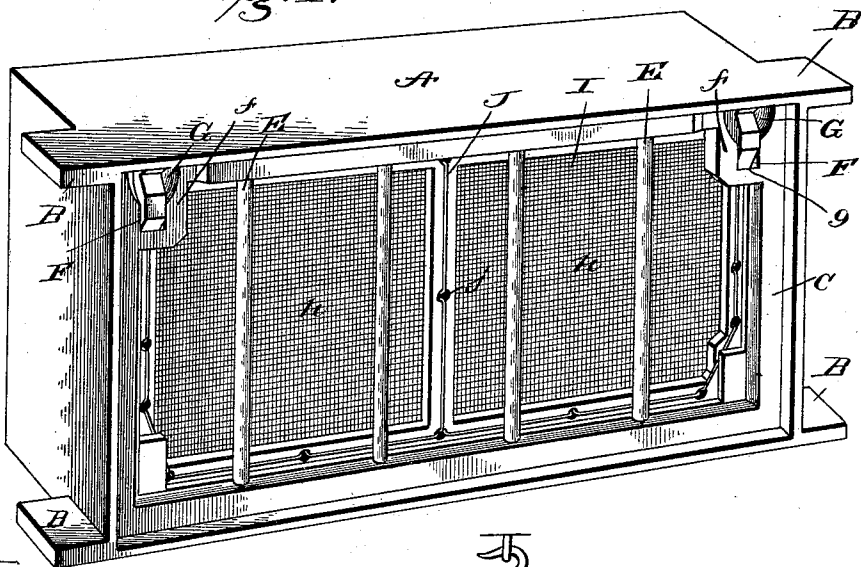

Fig. 2.

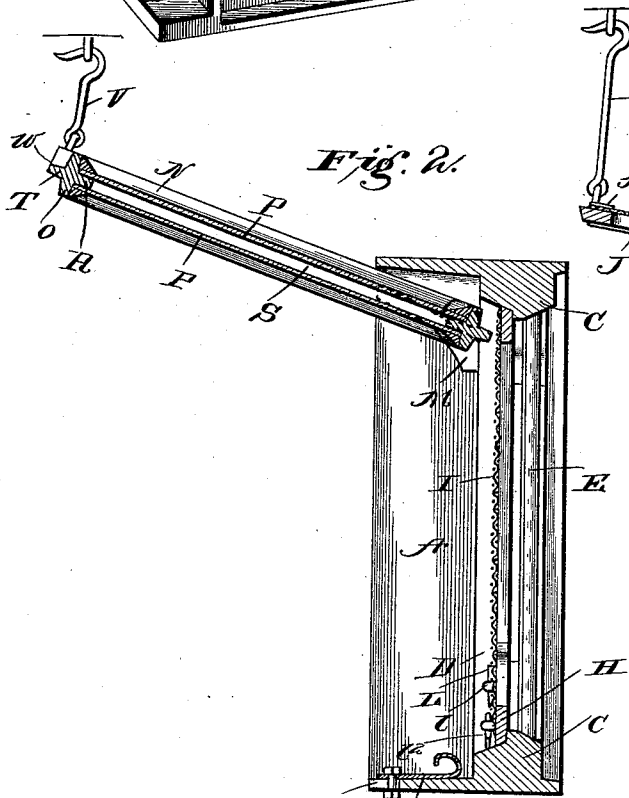
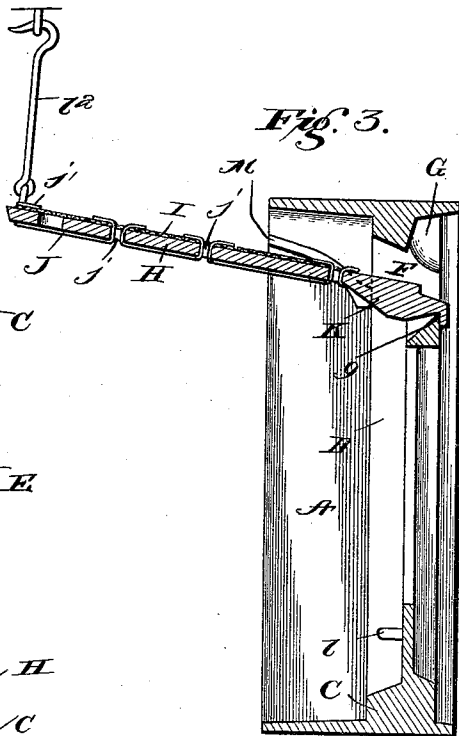

Fig. 3.



Inventor

Leonard Tremmel

By his Attorneys.

Chas. Snow & Co.

Witnesses

John C. Shaw
D. C. Hollander

(No Model.)

2 Sheets—Sheet 2.

L. TREMMEL.
CELLAR WINDOW.

No. 523,137.

Patented July 17, 1894.

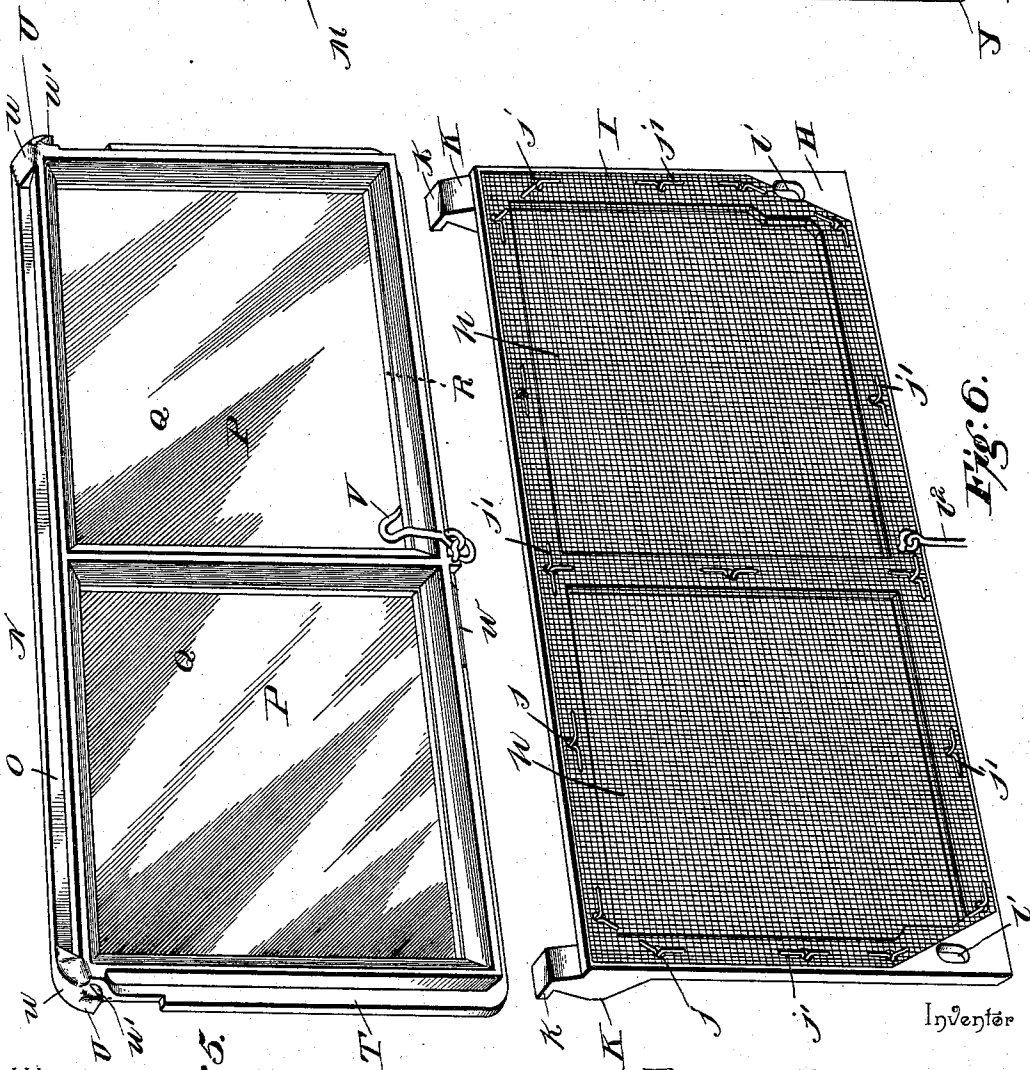
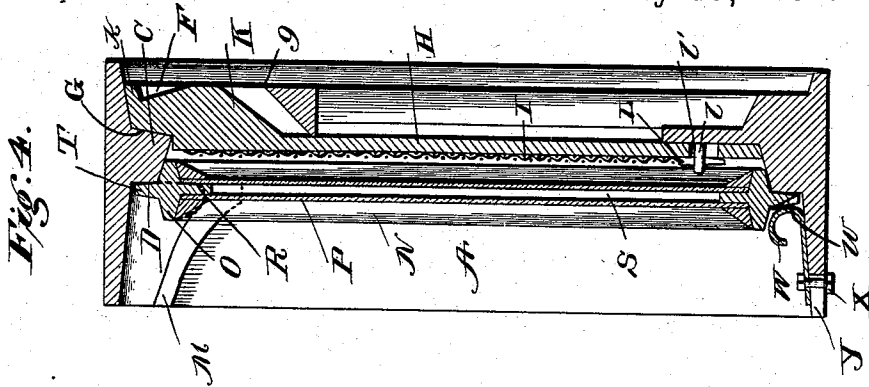

Witnesses

John Shaw
D. P. Walchaupt

Fig. 5.

By his Attorneys.

Leonard Tremmel,

Chas. Snow & Co.

UNITED STATES PATENT OFFICE.

LEONARD TREMMEL, OF WALTON, NEW YORK.

CELLAR-WINDOW.

SPECIFICATION forming part of Letters Patent No. 523,137, dated July 17, 1894.

Application filed December 11, 1893. Serial No. 493,444. (No model.)

To all whom it may concern:

Be it known that I, LEONARD TREMMEL, a citizen of the United States, residing at Walton, in the county of Delaware and State of New York, have invented a new and useful Cellar-Window, of which the following is a specification.

This invention relates to cellar or basement windows; and it has for its object to provide an improved window including the frame and sashes thereof, which shall be especially adapted for use within a wall at the point where cellar windows are usually located.

To this end the main and primary object of the invention is to provide a window of this character which shall be constructed with reference to its strength and durability so as to withstand the weight placed thereon without becoming misshapened or decayed, while at the same time providing simple and efficient means for effectually closing out the frost of winter, permitting a free circulation of air in the summer and warm weather, and also admitting of transferring objects or materials into the cellar or basement.

With these and other objects in view which will readily appear as the nature of the invention is better understood, the same consists in the novel construction, combination and arrangement of parts hereinafter more fully described, illustrated and claimed.

In the drawings:—Figure 1 is a perspective view of a cellar window constructed in accordance with this invention, showing the front or outer side thereof. Fig. 2 is a central transverse sectional view of the window showing the inner swinging sash swung open and the screen sash or frame closed. Fig. 3 is a similar view with the inner swinging sash removed and the screen frame swung in its open position. Fig. 4 is an enlarged transverse sectional view of the window near one end thereof and including the hinge connection of the swinging screen frame with the window frame. Fig. 5 is a detail in perspective of the inner double-lighted sash. Fig. 6 is a similar view of the screen frame or sash.

Referring to the accompanying drawings, A represents a rectangular window frame which is adapted to be built within the wall of a building at the point where the small cellar or basement windows are usually ar-

anged, and said rectangular frame A, is formed out of a single metal casting so as to complete a metal cellar-window which will be capable of withstanding any weight which might settle thereon, and will always preserve its shape and thereby render the sashes of the window easily opened and closed.

The open rectangular metallic window frame A, is provided at its opposite ends with integral upper and lower retaining or masonry lugs B, which project beyond the ends of the frame and secure a purchase in the masonry or wall built around the frame, and assist to hold such frame properly in position within the wall. Near the outer edge thereof, the open frame A, is further provided with an inner peripheral flange C, which flange C, is reduced at one side to form an inner shouldered edge D, inside of which fit the sashes of the window to be presently referred to, and the lower horizontal portion of the peripheral shouldered edge D, is inwardly beveled as clearly shown in the drawings. The peripheral flange C, extends continuously around the inner periphery or sides of the frame A, and the upper and lower portions of such flange are connected by the vertical grating bars E. The vertical grating bars E, are cast firmly into the metal of the frame to form a front grating for the outer exposed side of the window, and these grating bars not only serve to strengthen the frame against any weight placed thereon, but also prevent burglars or intruders from entering the cellar or basement of a building through the cellar window. It is to be also noted that the grating bars E, while subserving the functions just noted, are sufficiently wide apart to admit of coal and similar supplies to be passed into the cellar or basement.

At the upper opposite corners of the inner peripheral flange C, the same is provided with the vertically disposed hinge slots F. The hinge slots F, are mostly formed in the off-sets *f*, projected inwardly from the upper opposite corners of the flange C, as a part of such flange, and at the upper outer ends of the slots F, are formed the recesses or pockets G, while the corresponding lower ends or edges of the hinge slots are pointed as at *g*, for the purpose to be described.

A removable swinging screen frame or sash

H, is adapted to be detachably arranged at the inner side of the flange C, and when closed, to fit snugly within the inner shouldered edge D, thereof, and said screen frame or sash H, is provided with the separate screen openings *h*, which are covered by the screen I removably secured to the inner side of the frame H. The screen I, is preferably secured to the inner side of the frame I by means of the copper wire fasteners J, which are passed through the securing openings *j*, in the edges of the frame H, and have their ends bent upon themselves as at *j'*, to engage over the screen I, and hold it in place, it being noted that the copper wire fasteners will not rust and permit the screen to eventually work loose from its frame.

The screen frame H, is provided at its opposite upper corners with the off-standing hinge brackets or arms K, projected from one side of the frame and having at their outer extremities the hinge lips *k*. In placing the screen in position within the window frame, the upper edge of the screen frame is presented toward the flange C, and the off-standing hinge brackets or arms K, pass through the hinge slots F, which are located inside of the window frame and near the top thereof as described, and by then lowering the screen frame or sash to bring it snugly within the inner shouldered edge D, at one side of the flange C, the brackets or arms K, will be disposed in an upright position snugly within the recesses or pockets G, at the upper outer ends of the slots F. The screen is held locked in this closed position by means of suitable securing keys or pins L, removably passed through the pin eyes *l*, projected from the flange C, at the opposite lower corners thereof and adapted to pass through the eye openings *l'*, formed in the frame H, near its opposite lower corners. With the screen locked in this position a free circulation of air may be admitted to the cellar, while at the same time keeping out mice, flies, &c. By removing the pins or keys L, the screen may be readily lifted out of the window frame if desired, or may be simply swung up on its hinges and secured by the hook *l''*, in an open position, such hook being adapted to engage a suitable eye or fastening attached to the cellar ceiling. In swinging the screen frame up on its hinges, the brackets or arms K ride on the lower pointed edges of the slot F, and the hinge lips *k*, engage at the outer sides of such slots to securely hold the screen frame in position and prevent it from falling out of engagement with the window frame when being swung open.

The metallic casing A, is provided at directly opposite points on the opposite ends thereof with the inner curved supporting ribs M, which are located at one side of the inner peripheral flange C, and decline inwardly and downwardly from the inner edge of the window frame to the inner shouldered edge

D, of the flange C, and these inner supporting ribs M, serve to support and guide in position the inner swinging double sash N. The inner swinging double sash N, consists of the metallic sash frame O, and the window lights P. The sash frame O, is provided with the separate sash openings Q, which are encircled by a central dividing flange R, extending entirely around the light openings at a point intermediate of the opposite side edges of the sash frame, and serve to separate the window lights P, one of which is placed at each side of the dividing flange R, in each light opening, so as to complete a double lighted sash having air spaces S, formed between the separated lights P, thereof, it being clearly seen from the drawings that there are two lights to each light opening, and by reason of this construction a warm air space is formed which will prevent the cold or frost from penetrating into the cellar or basement in very cold weather.

The inner swinging sash N, or more properly speaking the sash-frame thereof, is surrounded by an external rib T, which admits of one side of the sash fitting snugly within the shouldered edge D, and at the upper opposite corners thereof is further provided with the projected hinge lugs U, beveled at the top as at *u*, to provide for passing in the space between the top of the window frame and the ribs M, and provided with lower curved bearing edges *u'*, which bear on top of the ribs M, to provide for the hinging of the sash N.

In placing the sash N, in position, the pointed ends of the lugs U, are passed into the space above the ribs M, and after reaching the inner side of the flange C, will have a movement above the said ribs sufficient to permit the inner sash being swung open and closed. When swung open, the inner sash is held in such a position by means of a supporting hook V, attached to the lower edge thereof and adapted to engage any convenient point of attachment, but when closed, the said inner sash is held snugly at one side of and partly within the shouldered edge D, to form an air and water tight joint therewith, by means of the removable lock spring W. The spring W, is curved or beveled so as to be freely engaged by the beveled lower edge *w*, of the sash N, when the same is being opened against the pressure of such spring, and the latter is removably held in position by means of the bolt X, fitted into the notch or slot Y, formed in the lower inner edge of the sash frame A.

From the foregoing description it will be apparent that by reason of the detachable and hinge mounting of the sash and screen frame, either or both of these parts of the window may be used at one time, and together complete a window which is well adapted for the purposes herein referred to, and I will have it understood that changes in the form, proportion and the minor details of construction

may be resorted to without departing from the principle or sacrificing any of the advantages of this invention.

Having thus described this invention, what is claimed, and desired to be secured by Letters Patent, is—

1. In a cellar window, the combination of a rectangular metallic frame having a front grating, an inner peripheral flange, and supporting ribs at one side of said flange, a screen detachably hinged at one side of said flange, and a glazed sash provided with oppositely disposed hinge lugs adapted to work on top of said supporting ribs, substantially as set forth.

2. The combination with a window frame, having an inner shouldered peripheral flange of the metallic sash mounted within said window frame and having an external rib adapted to fit at one side of the shouldered peripheral flange, light openings and central dividing flanges encircling the light openings at an intermediate point, and separated window lights arranged within the light openings at both sides of the dividing flanges to inclose therebetween warm air spaces, substantially as set forth.

3. In a cellar window, the combination with the metallic rectangular frame having an inner shouldered peripheral flange, and inwardly declining supporting ribs at one side of said flange, and an inner swinging glazed sash having an external rib adapted to fit at one side of the shouldered edge of the peripheral flange, and oppositely disposed hinge lugs working on top of said supporting ribs, substantially as set forth.

4. In a cellar window, the combination of the frame having an inner peripheral flange, and inner curved supporting ribs located at one side of said flange and declining inwardly within the frame, and a swinging glazed sash detachably mounted within the window frame and having at its upper opposite corners projected hinge lugs beveled at the top and pro-

vided with lower curved bearing edges adapted to engage on top of said curved supporting ribs, substantially as set forth.

5. In a cellar window, the combination of the open metallic frame having a front grating, an inner peripheral flange having a shouldered edge at one side and vertically disposed hinge slots at the upper opposite corners thereof, and a removable screen detachably arranged at one side of the inner flange and provided with opposite off-standing hinge brackets or arms loosely engaging said hinge slots, substantially as set forth.

6. In a cellar window, the metallic frame having an inner peripheral flange provided at its upper opposite corners with vertically disposed hinge slots, recesses or pockets at the upper outer ends of said slots, and inwardly projecting pin-eyes at the corresponding lower opposite corners, a removable screen frame adapted to register at one side of said inner flange and having eye openings to receive said pin-eyes, and off-standing hinge brackets or arms, adapted to loosely engage said hinge slots and provided at their outer extremities with hinge lips, and suitable pins or keys adapted to engage said pin eyes at one side of the screen frame, substantially as set forth.

7. In a window of the class described, the window casing having a notch or slot at the lower inner edge thereof, a removable swinging sash detachably hinged at its upper end within the window frame and provided with a lower beveled edge, a bolt removably fitted into said notch or slot, and a curved removable lock spring attached to said bolt and normally bearing against the lower edge of said sash, substantially as set forth.

In testimony that I claim the foregoing as my own I have hereto affixed my signature in the presence of two witnesses.

LEONARD TREMMEL.

Witnesses:

LEWIS BUSH,
M. W. MARVIN.