



(12) UK Patent (19) GB (11) 2 151 382 B

(54) Title of invention
File deletion system

(51) INTCL⁴; G06F7/00

(21) Application No
8431288

(22) Date of filing
12 Dec 1984

(30) Priority data

(31) **58/233630**

(32) **13 Dec 1983**

(33) **Japan (JP)**

(43) Application published
17 Jul 1985

(45) Patent published
19 Nov 1986

(73) Proprietors
**Oki Electric Industry Co Ltd
(Japan)
7-12 Toranomom 1-chome
Minato-ku
Tokyo
Japan**

(72) Inventors
**Mitsuji Furusawa
Osamu Ueno
Hideyuki Kobayashi**

(74) Agent and/or
Address for Service
**Gill, Jennings & Every,
53-64 Chancery Lane,
London WC2A 1HN**

(52) Domestic classification
(Edition H)
G4H 13D 1A TAA

(56) Documents cited
None

(58) Field of search
**G4H
H4T**

Fig. 1 (A)

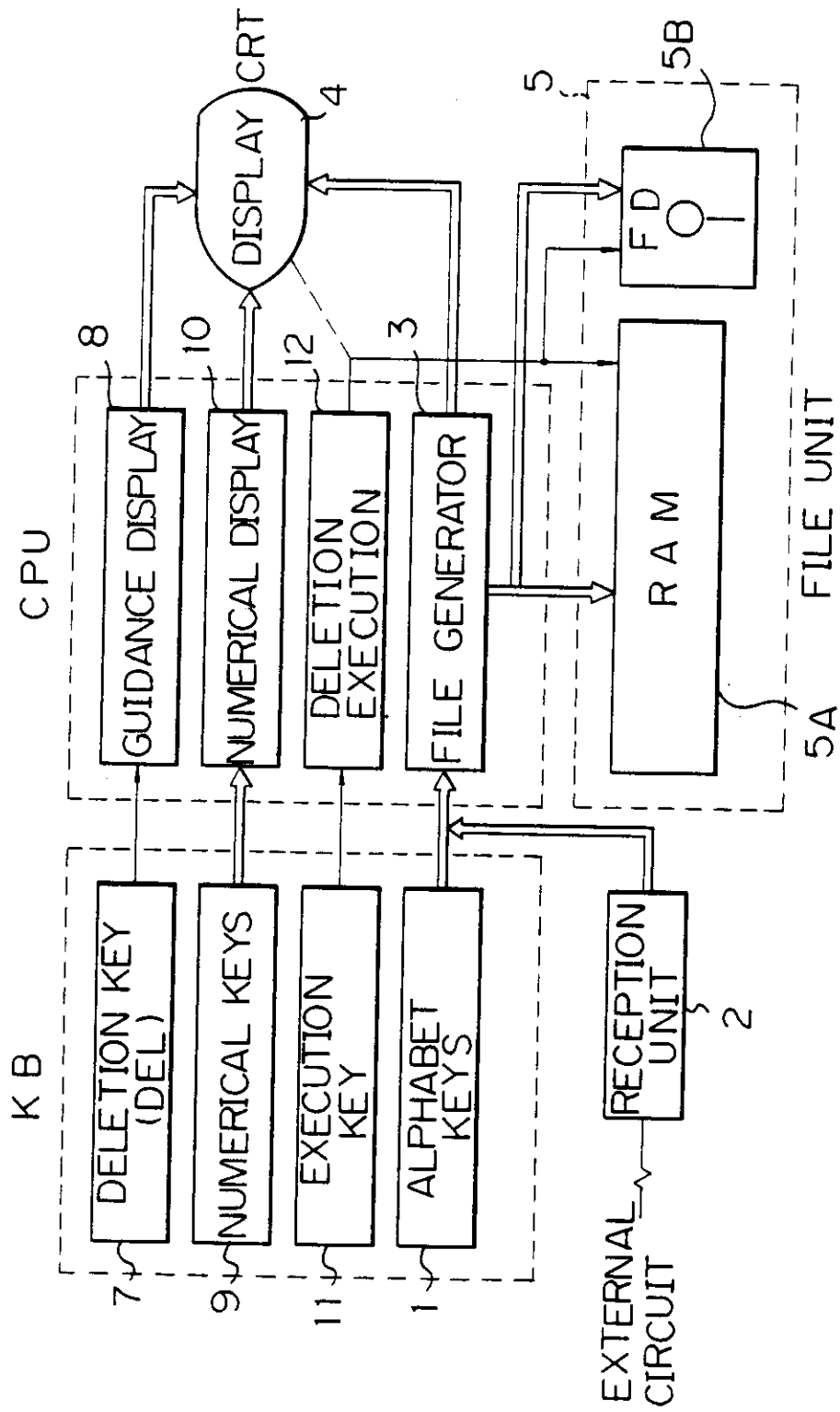
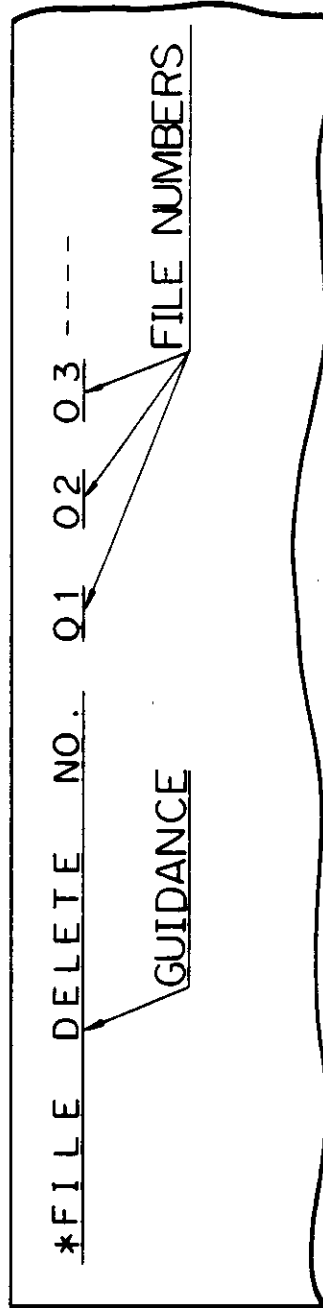

Fig. 1(B)



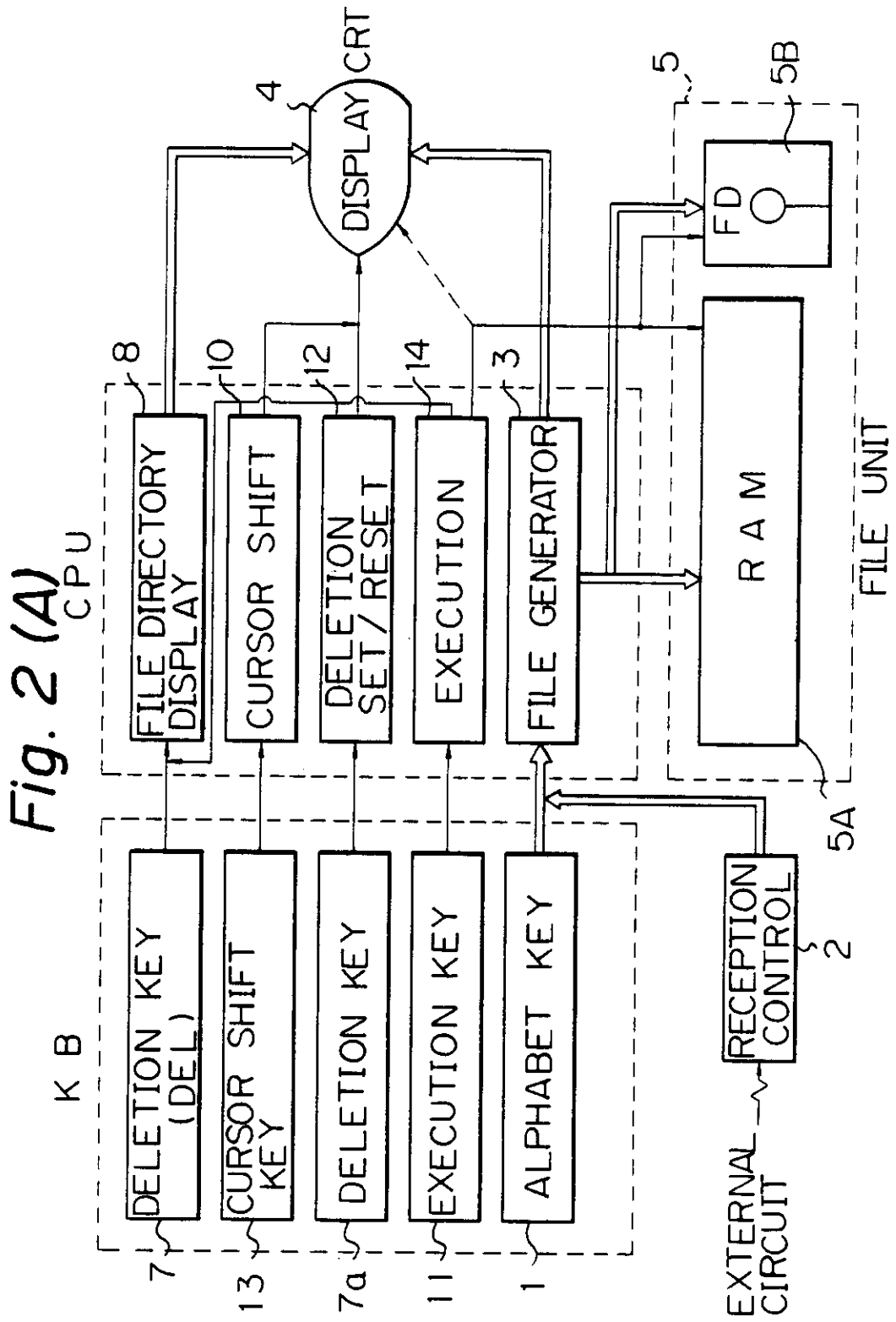

Fig. 2 (A)

CPU

K B

FILE UNIT

Fig. 2(B)

```

*FILE DIRECTOR Y-ALL TITLE
*01P(001):THE QUICK BROWN---
*02S(010):MT-100 VSR TELEP---
*03R(100):ABCDEFGHIJKLMNOP
}
*10P(200):XYZ
END

```

```

1
2
3
4
-
-
↑

```

Fig. 3

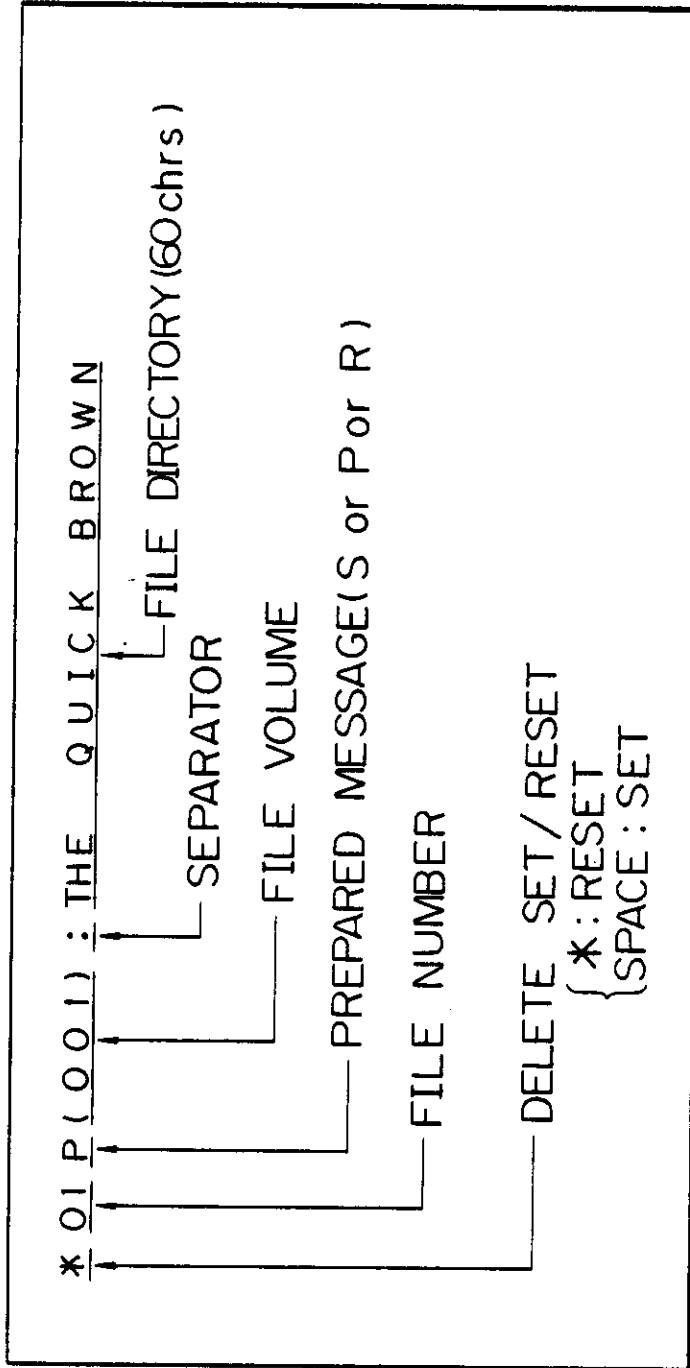

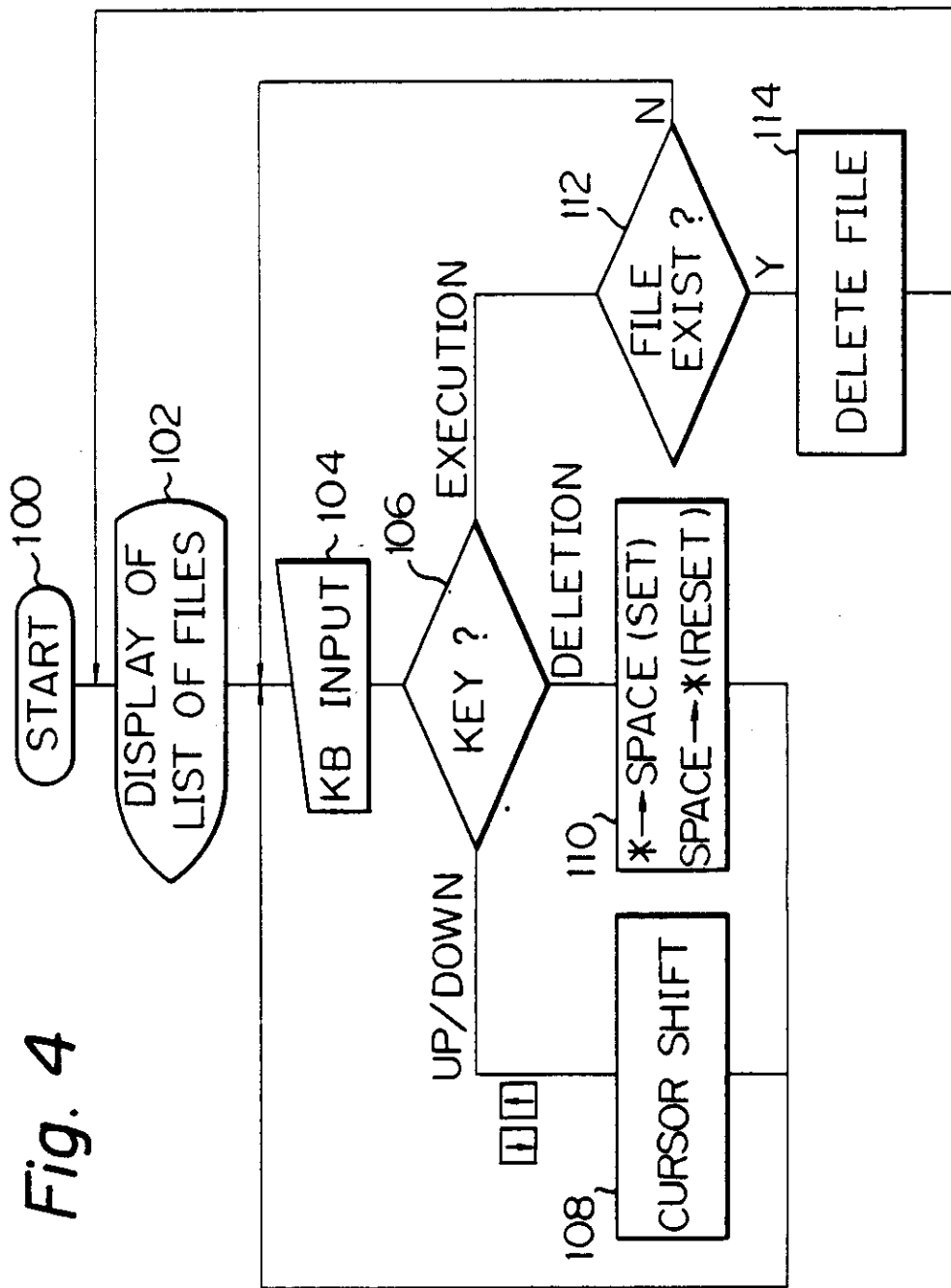

Fig. 4

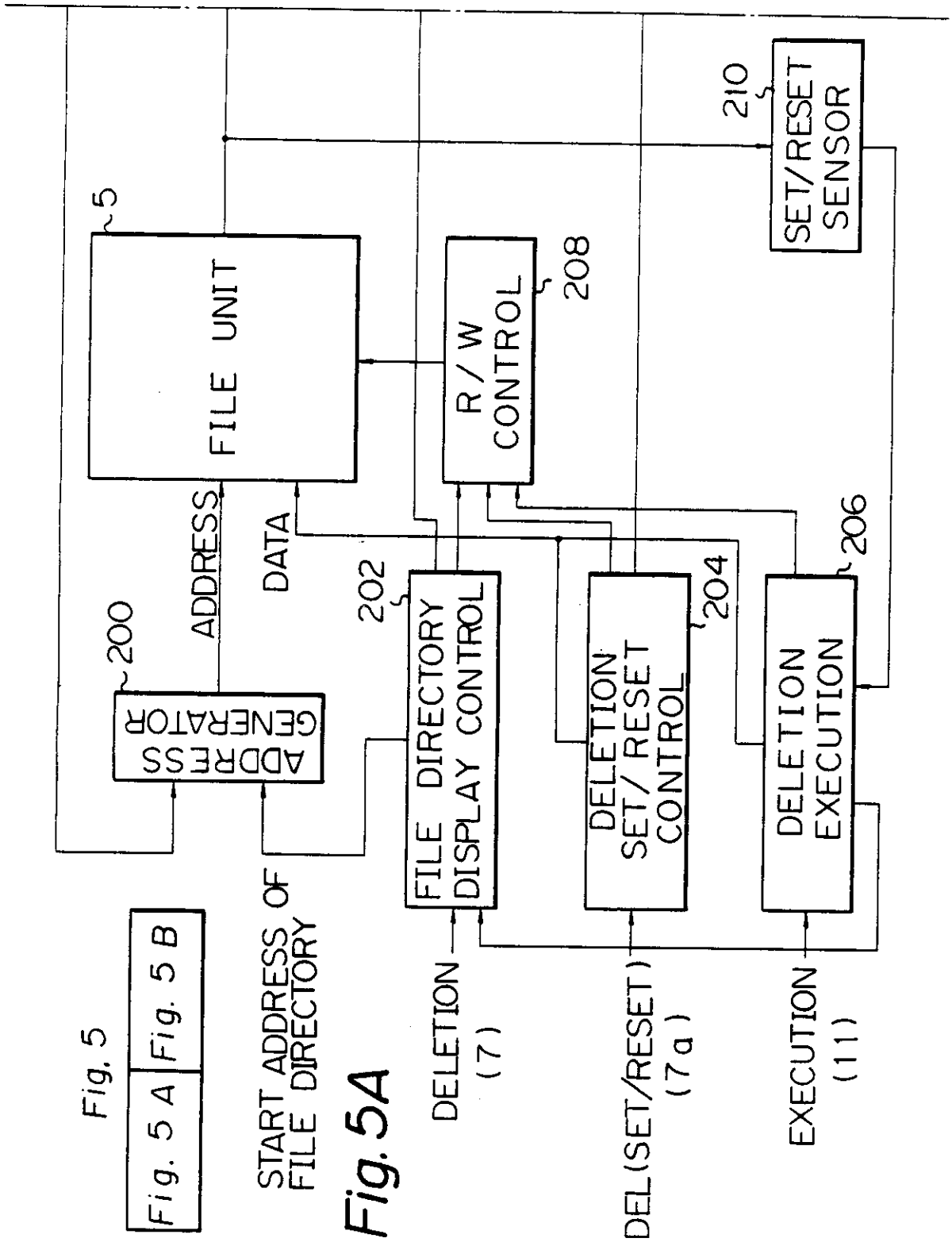

Fig. 5

Fig. 5 A Fig. 5 B

START ADDRESS OF FILE DIRECTORY

Fig. 5A

DELETION (7)

DEL(SET/RESET) (7a)

EXECUTION (11)

Fig. 5B

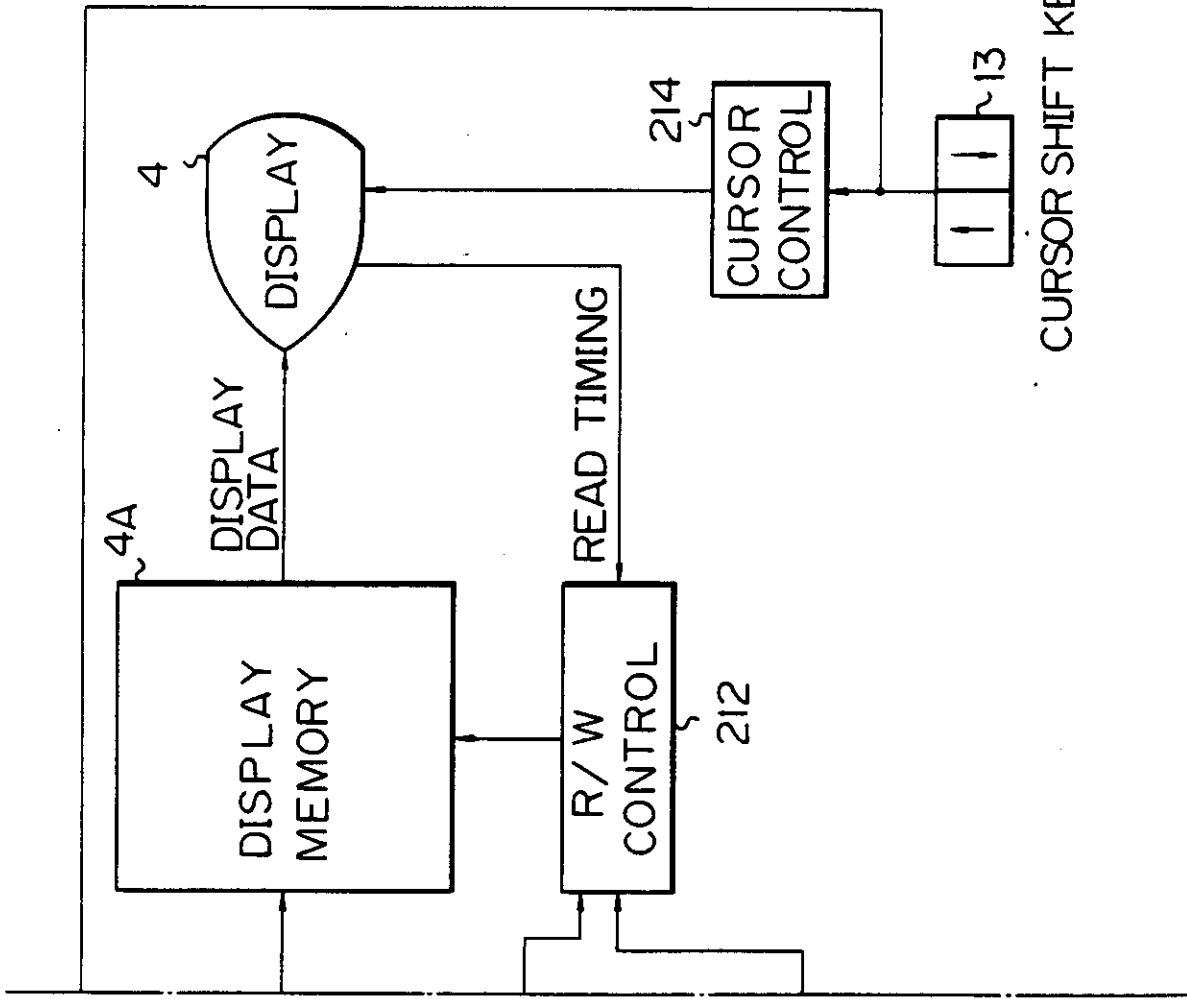

FILE DELETION SYSTEM

This invention relates to a file deletion system which deletes designated messages in a file memory, such as a floppy disc. It can be usefully applied to, for example, a telex^(RTM) terminal, a word processor or a personal computer.

A conventional file deletion system is shown in Figure 1A of the accompanying drawings. The system comprises a keyboard KB, a programmed processor CPU, a cathode ray tube display CRT, alphabet keys 1 for generation of a message, a receiver unit 2 which receives a message from an input line, a file generator 3 for generating a file which is to be stored, a screen 4 for indicating input data and guidance information, a file unit 5 having a random access memory 5A and a floppy disc 5B for storing files, a deletion key 7 for designating deletion of a file, a guidance display circuit 8 for producing signals for the display of guidance information on the screen 4, numerical keys 9 for designating the number of a file to be deleted, a numerical display control 10 for producing signals for the display of numbers of files to be deleted, an execution key 11 for initiating deletion of the designated message, and a deletion execution circuit 12 for executing the deletion of a designated message on the RAM or the floppy disc.

When a new message is fed in by the alphabet keys 1 or the receiver unit 2, the file generator 3 designates an available file number which is not used for a message, and the input data are displayed on the screen 4. The message is then recorded in the file unit with the designated file number. Thus, a plurality of files are generated in the floppy disc 5B of the file unit 5.

When it is desired to delete a message from the file unit 5, the operator depresses the deletion key 7, and

the guidance display means 8 causes the display of guidance information on the screen 4. An example of the guidance information is shown in Figure 1B. Then the operator depresses selected numerical keys 9 to designate the number of the message to be deleted. That number is fed to the numeral display control 10, which displays on the screen 4 the number of the message to be deleted. When a plurality of messages are deleted simultaneously, a plurality of numbers are indicated as shown in Figure 10 1B. When the numbers of the messages to be deleted are indicated on the screen 4, the operator depresses the execution key 11, and deletion of the designated messages is carried out. The deletion execution means 12 reads the number to be deleted as indicated on the screen 4.

15 Accordingly, the conventional file deletion system shown in Figures 1A and 1B has the disadvantages that the message is identified by merely the file number, and therefore the operator must have a list of messages to check the message number and the content of the message, and misoperation, which causes deletion of a message 20 which should not have been erased, frequently occurs.

It is an object of the present invention to provide a new and improved file deletion system which indicates not only a message number, but also at least a part of 25 the content of the message to be deleted.

According to the invention, there is provided a file deletion system for deleting a particular message stored in a file unit, comprising a keyboard; display means for displaying data; file generator means for generation and 30 editing of a message by use of the keyboard and the display means, the message generated by the file generator means being stored in the file unit; file directory control means for causing a file directory list of messages to be shown on the display means in response 35 to actuation of a first key of the keyboard, the file

directory including a deletion set or reset code and a group of initial characters of each message; cursor control means for shifting a cursor on the display means in response to actuation of at least one second key of the keyboard and for causing the cursor to locate on the deletion set or reset code of a first message upon actuation of said first key; deletion set or reset control means actuatable by a third key of the keyboard to change the set or reset code indicated by the cursor from a set code to a reset code or vice versa; and deletion executing means for deleting from the file unit a message with a deletion set code, designated by the file directory, upon depression of a fourth key of the keyboard.

Embodiments of the invention will now be described, by way of example, with reference to the accompanying drawings, in which

Figure 1A is a block diagram of a prior file deletion system as described above,

Figure 1B shows an example of part of a message displayed by the apparatus of Figure 1A,

Figure 2A is a block diagram of a file deletion system according to the invention,

Figure 2B shows an example of part of a message displayed by the apparatus of Figure 2A,

Figure 3 shows an example of details of a display in a system according to the invention,

Figure 4 is a flow diagram of the operation of the present file deletion system, and

Figure 5 is another block diagram of a file deletion system according to the invention.

In Figure 2A, the references 1 to 7 indicate the same components as in Figure 1A. The central processing unit CPU is programmed so that it has the following functions; a file directory display function 8 which

causes the screen 4 to display a directory of the file unit 5, in response to depression of the deletion key 7; a cursor shift function 10 which shifts a cursor on the screen in response to operation of the cursor up and down shift keys 13; a deletion set/reset function 12 which sets or rests a deletion code on the screen 4 in response to depression of a deletion key 7a; an execution function 14 which executes the actual deletion of a designated message upon depression of the execution key 11; and a file generation function 3 which is the same as the conventional one in Figure 1A.

The keyboard KB has the deletion keys (DEL) 7 and 7a for entering the file deletion operation, and setting and resetting of the deletion of the files, the cursor up and down shift keys 13, and the execution key 11 for the actual execution of the deletion.

The deletion key 7a may double for the other deletion key 7. The keyboard KB also has the alphanumeric keys 1 for data input.

When a particular message which is stored in the file unit 5 is to be deleted, an operator depresses the deletion key 7, and the file directory display function 8 then displays the file directory of the messages stored in the file unit 5 (box 102 in Figure 4). The format of the display is shown briefly in Figure 2B, and is shown in detail in Figure 3, in the case of a telex^(RTM)/terminal.

In Figure 2B, or Figure 3, the first line (*FILE DIRECTORY-ALL) shows merely the title of the display. Each line of the display except the first line has the set/reset code (*or a space). When that code is *, the message following the symbol * on the line is not deleted, and when the code is a space, the message following the code is to be deleted by the next operation. That code (* or space) is changed alternately by depressing the deletion key 7a. The second term of

the file directory (01,02,---, 10) shows the file number. The next one bit code (P or S or R) shows the attribute or the nature of the message in the case of a telex^(RTM) terminal. When the attribute code is "P", the message is a prepared message which is to be transmitted, when the code is "S", the message is a message which has been sent already, and when the code is "R", the message is a received message.

The next figures in parentheses show the file volume or the length of the message and how many lines the message has. The next code ":" is merely a separator on the screen. Following the separator ":", the first 60 characters of the message are displayed.

Accordingly, the file directory thus displayed by use of the invention gives detailed information regarding the message, which is different from that of the prior display of Figure 1B, and an operator can recognise and identify the message using only the display.

When the file directory is displayed, the cursor is located at the first line of the message, and at the extreme left column on the set/reset code as shown by the rectangular box in Figure 2B.

At the end of the file directory display, the code END is displayed to show the end of the display (see Figure 2B).

It will now be assumed that the message No. 03, which is the received message having 100 lines beginning with characters indicated by ABCDEFGHIJK---, is to be deleted.

In that case, the operator depresses the cursor shift down key 13 twice so that the cursor shifts to the fourth line, which shows the message 03, from the second line on which the cursor was previously located (the operation is shown in the flow chart of Figure 4 as proceeding from a box 104, boxes 106 and 108 and back to

the box 104). The cursor shift function 10 (Figure 2A) then shifts the cursor downwards by two lines.

Next, the operator depresses the deletion set/reset key 7a, and the deletion function 12 then changes the set/reset code at the end of the fourth line from (*) to a space, which indicates that the message is to be deleted. Designation of deletion of a plurality of messages is possible by changing a plurality of the (*) codes to the space codes. If the deletion key 7a is depressed again, the space code returns to the (*) code which shows that the message is not deleted. Therefore, the depression of the deletion key 7a switches the message indicated by the cursor from a deletion message to a non-deletion message or vice versa. The operation of the depression of the deletion key 7a is shown by the path through the boxes 104, 106 and 110 in Figure 4.

Next, the operator depresses the execution key 11, and the execution function 14 then executes the deletion of the messages having the space code at the set/reset code location. In the present embodiment, the message 03 is deleted. After completion of the deletion, the new file directory, which does not include the deleted messages, is displayed on the screen. The operation of the depression of the execution key 11 is shown by the path through the boxes 104, 106, 112 and 114 in Figure 4.

The above operation is carried out either by a programmed computer as shown in Figure 2A, or a hardware configuration as shown in Figure 5. The apparatus in Figure 5 comprises a display 4, a display memory 4A, a file unit 5, cursor up and down shift keys 13, an address generator 200 for feeding address information to the file unit 5, a file directory display control 202, a deletion set/reset control 204, a deletion execution control 206, a read/write control 208 for the file unit 5, a set/reset sensor 210 which detects whether the set/reset code of

each message in the file unit has the deletion code (space) or the non-deletion code (*), a read/write control 212 for the display memory 4A, a cursor control 214 for location of the cursor on the screen 4 in response to depression of the cursor shift keys 13.

In operation, upon depression of the deletion key 7, the file directory display control 202 reads the file directory in the file unit 5, and the file directory thus read out is written in the display memory 4A, the content of which is displayed on the screen 4. The cursor is located at the left hand end of the first message, as shown in Figure 2B.

Then, upon depression of the cursor shift keys 13, the cursor shifts upward or downward. With the shifting of the cursor, the address generator 200 provides the address at which the message designated by the cursor is stored.

Then, upon depression of the deletion set/reset key 7a, the deletion set/reset control 204 changes the (*) code to the space, and changes the space to the (*) code, both in the file unit 5 and in the display memory 4A.

Next, upon depression of the execution key 11, the deletion execution control 206 deletes the message with the deletion code (a space) in the file unit 5. After the deletion of the message, the new file directory is displayed on the screen 4.

Accordingly, it should be appreciated that the message to be deleted is indicated not only with the file number, but also with the initial 60 characters of the file and, therefore, an operator can identify the message to be deleted. Also, the message to be deleted is designated by a set/reset code (* or space) on each line. Therefore, a mistake in the designation of a deletion message is prevented.

CLAIMS

1. A file deletion system for deleting a particular message stored in a file unit, comprising a keyboard; display means for displaying data; file generator means
5 for generation and editing of a message by use of the keyboard and the display means, the message generated by the file generator means being stored in the file unit; file directory control means for causing a file directory list of messages to be shown on the display means in
10 response to actuation of a first key of the keyboard, the file directory including a deletion set or reset code and a group of initial characters of each message; cursor control means for shifting a cursor on the display means in response to actuation of at least one second key of
15 the keyboard and for causing the cursor to locate on the deletion set or reset code of a first message upon actuation of said first key; deletion set or reset control means actuatable by a third key of the keyboard to change the set or reset code indicated by the cursor
20 from a set code to a reset code or vice versa; and deletion executing means for deleting from the file unit a message with a deletion set code, designated by the file directory, upon depression of a fourth key of the keyboard.

25 2. A system according to claim 1, wherein a single key which functions as both said first key and said third key is provided on the keyboard.

3. A system according to claim 1 or claim 2, wherein the file directory of each message is indicated
30 in one respective line on the display means.

4. A system according to any preceding claim, wherein the file unit comprises a floppy disc unit.

5. A file deletion system substantially as hereinbefore described, with reference to Figures 2A to
35 5B of the accompanying drawings.

Publication No.
2151382 A dated 17 July 1985

Patent Granted: SECTION 25(1) 19 NOV 1986

Application No.
8431288 filed on 12 December 1984

Priority claimed:
13 December 1983 in Japan doc: 58/233630

Title:
File deletion system

Applicant:
Oki Electric Industry Co Ltd (Japan), 7-12 Toranomon 1-chome, Minato-ku, Tokyo, Japan.

Inventors:
Mitsuji Furusawa, c/o Oki Electric Industry Co Ltd, 7-12 Toranomon 1-chome, Minato-ku, Tokyo, Japan.

Osamu Ueno, c/o Oki Electric Industry Co Ltd, 7-12 Toranomon 1-chome, Minato-ku, Tokyo, Japan.

Hideyuki Kobayashi, c/o Oki Electric Industry Co Ltd, 7-12 Toranomon 1-chome, Minato-ku, Tokyo, Japan.

Classified to:
G4H

Examination requested 12 December 1984

Address for Service:
Gill Jennings & Every, 53-64 Chancery Lane, London WC2A 1HN.