

(12) STANDARD PATENT
(19) AUSTRALIAN PATENT OFFICE

(11) Application No. **AU 2006256924 B2**

(54) Title
Sock

(51) International Patent Classification(s)
A41B 11/00 (2006.01) **D04B 1/26** (2006.01)

(21) Application No: **2006256924** (22) Date of Filing: **2006.06.09**

(87) WIPO No: **WO06/131380**

(30) Priority Data

(31) Number	(32) Date	(33) Country
10 2005 027 100.6	2005.06.10	DE
10 2005 043 821.0	2005.09.13	DE

(43) Publication Date: **2006.12.14**

(44) Accepted Journal Date: **2012.01.12**

(71) Applicant(s)
X-Technology Swiss GmbH

(72) Inventor(s)
Lambertz, Bodo W.

(74) Agent / Attorney
Davies Collison Cave, Level 14 255 Elizabeth Street, Sydney, NSW, 2000

(56) Related Art
DE20016825
US5353524
CA2541455
DE20111503
US5724836

(12) NACH DEM VERTRAG ÜBER DIE INTERNATIONALE ZUSAMMENARBEIT AUF DEM GEBIET DES PATENTWESENS (PCT) VERÖFFENTLICHTE INTERNATIONALE ANMELDUNG

(19) Weltorganisation für geistiges Eigentum
Internationales Büro



(43) Internationales Veröffentlichungsdatum
14. Dezember 2006 (14.12.2006)

PCT

(10) Internationale Veröffentlichungsnummer
WO 2006/131380 A3

- (51) Internationale Patentklassifikation:
A41B 11/00 (2006.01) D04B 1/26 (2006.01)
- (21) Internationales Aktenzeichen: PCT/EP2006/005509
- (22) Internationales Anmeldedatum:
9. Juni 2006 (09.06.2006)
- (25) Einreichungssprache: Deutsch
- (26) Veröffentlichungssprache: Deutsch
- (30) Angaben zur Priorität:
10 2005 027 100.6 10. Juni 2005 (10.06.2005) DE
10 2005 043 821.0
13. September 2005 (13.09.2005) DE
- (71) Anmelder (für alle Bestimmungsstaaten mit Ausnahme von US): X-TECHNOLOGY SWISS GMBH [CH/CH]; Samstagerstrasse 45, CH-8832 Wollerau (CH).
- (72) Erfinder; und
- (75) Erfinder/Anmelder (nur für US): LAMBERTZ, Bodo, W. [DF/CH]; Fitzelstrasse 25, CH-8808 Pfäffikon (CH).
- (74) Anwalt: DÖRNER, KÖTTER & KOLLEGEN; Stresemannstrasse 15, 58095 Hagen (DE).
- (81) Bestimmungsstaaten (soweit nicht anders angegeben, für jede verfügbare nationale Schutzrechtsart): AE, AG, AL, AM, AT, AU, AZ, BA, BB, BG, BR, BW, BY, BZ, CA, CH, CN, CO, CR, CU, CZ, DE, DK, DM, DZ, EC, EE, EG, ES, FI, GB, GD, GE, GH, GM, HR, HU, ID, IL, IN, IS, JP, KE, KG, KM, KN, KP, KR, KZ, LC, LK, LR, LS, LT, LU, LV, LY, MA, MD, MG, MK, MN, MW, MX, MZ, NA, NG, NI, NO, NZ, OM, PG, PH, PL, PT, RO, RU, SC, SD, SE, SG, SK, SL, SM, SY, TJ, TM, TN, TR, TT, TZ, UA, UG, US, UZ, VC, VN, YU, ZA, ZM, ZW.
- (84) Bestimmungsstaaten (soweit nicht anders angegeben, für jede verfügbare regionale Schutzrechtsart): ARIPO (BW,

[Fortsetzung auf der nächsten Seite]

(54) Title: SOCK

(54) Bezeichnung: SOCKE MIT KLIMAKANAL

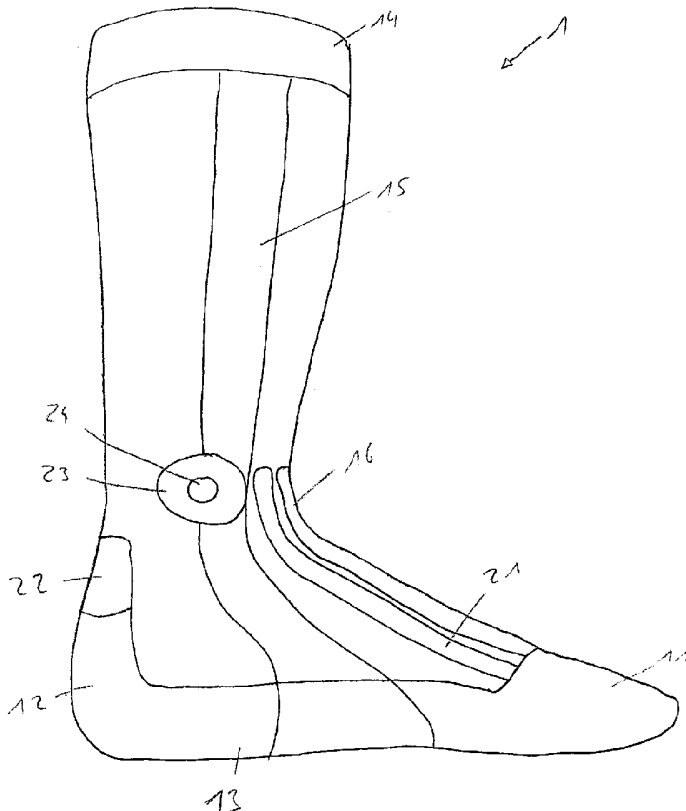

(57) Abstract: The invention relates to a sock, in particular for use during sports, said sock comprising cushioned sections. A ventilation channel (16), which is preferably positioned between at least two parallel cushioned sections (21), is situated on the dorsum of the foot (17).

(57) Zusammenfassung: Die Erfindung betrifft eine Socke, insbesondere zum Einsatz bei sportlichen Aktivitäten, die bereichsweise eine Polsterung aufweist, wobei auf dem Fußrücken (17) ein Klimakanal (16) angeordnet ist, der bevorzugt zwischen mindestens zwei parallel zueinander angeordneten Polsterungen (21) vorgesehen ist.

WO 2006/131380 A3



GH, GM, KE, LS, MW, MZ, NA, SD, SL, SZ, TZ, UG, ZM, ZW), eurasisches (AM, AZ, BY, KG, KZ, MD, RU, TJ, TM), europäisches (AT, BE, BG, CH, CY, CZ, DE, DK, EE, ES, FI, FR, GB, GR, HU, IE, IS, IT, LT, LU, LV, MC, NL, PL, PT, RO, SE, SI, SK, TR), OAPI (BF, BJ, CF, CG, CI, CM, GA, GN, GQ, GW, ML, MR, NE, SN, TD, TG).

Erklärung gemäß Regel 4.17:

— *Erfindererklärung (Regel 4.17 Ziffer iv)*

Veröffentlicht:

— *mit internationalem Recherchenbericht*

(88) Veröffentlichungsdatum des internationalen

Recherchenberichts:

8. März 2007

Zur Erklärung der Zweibuchstaben-Codes und der anderen Abkürzungen wird auf die Erklärungen ("Guidance Notes on Codes and Abbreviations") am Anfang jeder regulären Ausgabe der PCT-Gazette verwiesen.

(12) INTERNATIONAL PATENT OFFICE

WORLD ORGANIZATION FOR INTELLECTUAL PROPERTY

(19) International patent published on

the basis of the Patent Cooperation Treaty

(10) INTERNATIONAL PUBLICATION NO. WO 2006/131380 A2

(51) International Patent Classification: A 41 B 11/00 (2006.01)

D 04 B 1/26 (2006.01)

(21) International Filing No.: PCT/EP2006/005509

(22) International Filing Date: June 9, 2006

(43) International Publication Date: December 14, 2006

(30) Priority

Date: June 10, 2005

Country: DE

No.: 10 2005 027 100.6

Date: September 13, 2005

Country: DE

No.: 10 2005 043 821.0

(25) Language of Submission: German

(26) Language of Publication: German

(54) SOCK

(72) Inventor; and

(75) Inventor/Applicant (only for US): Bodo W. Lambertz [DE/CH]
 Etzelstrasse 25
 CH-8808 Pfäffikon (CH)

(71) Applicant (for all designated
 states except US):

X-TECHNOLOGY SWISS GMBH
 [CH/CH]
 Samstagernstrasse 45
 CH-8832 Wollerau (CH)

(74) Agent:

DÖRNER, KÖTTER &
 KOLLEGEN
 Stresemannstrasse 15
 58095 Hagen (DE)

Designated States (unless otherwise specified, for
 every available type of national legal protection):

AE, AG, AL, AM, AT, AU, AZ, BA,
 BB, BG, BR, BW, BY, BZ, CA, CH,
 CN, CO, CR, CU, CZ, DE, DK, DM,
 DZ, EC, EE, EG, ES, FI, GB, GD,
 GE, GH, GM, HR, HU, ID, IL, IN,
 IS, JP, KE, KG, KM, KN, KP, KR,
 KZ, LC, LK, LR, LS, LT, LU, LV,
 LY, MA, MD, MG, MK, MN, MW,
 MX, MZ, NA, NG, NI, NO, NZ,

OM, PG, PH, PL, PT, RO, RU, SC,
 SD, SE, SG, SK, SL, SM, SY, TJ,
 TM, TN, TR, TT, TZ, UA, UG, US,
 UZ, VC, VN, YU, ZA, ZM, ZW

Designated States (unless otherwise specified, for
 every available type of regional legal protection):

ARIPO (BW, GH, GM, KE, LS,
 MW, MZ, NA, SD, SL, SZ, TZ, UG,
 ZM, ZW), Eurasian (AM, AZ, BY,
 KG, KZ, MD, RU, TJ, TM),
 European (AT, BE, BG, CH, CY,
 CZ, DE, DK, EE, ES, FI, FR, GB,
 GR, HU, IE, IS, IT, LT, LU, LV,
 MC, NL, PL, PT, RO, SE, SI, SK,
 TR), OAPI Patent (BF, BJ, CF, CG,
 CI, CM, GA, GN, GQ, GW, ML,
 MR, NE, SN, TD, TG)

Declaration according to Rule 4.17:

- Inventor's declaration (Rule 4.17 number iv)

Published

- Without International Search Report; must be republished after the receipt of the report

For an explanation of the two-letter codes and the other abbreviations, please refer to the explanations ("Guidance Notes on Codes and Abbreviations") at the start of each regular edition of the PCT Bulletin.

(57) Abstract: The invention relates to a sock, in particular for use during sports, said sock comprising cushioned sections. A ventilation channel (16), which is preferably positioned between at least two parallel cushioned sections (21), is situated on the dorsum of the foot (17).

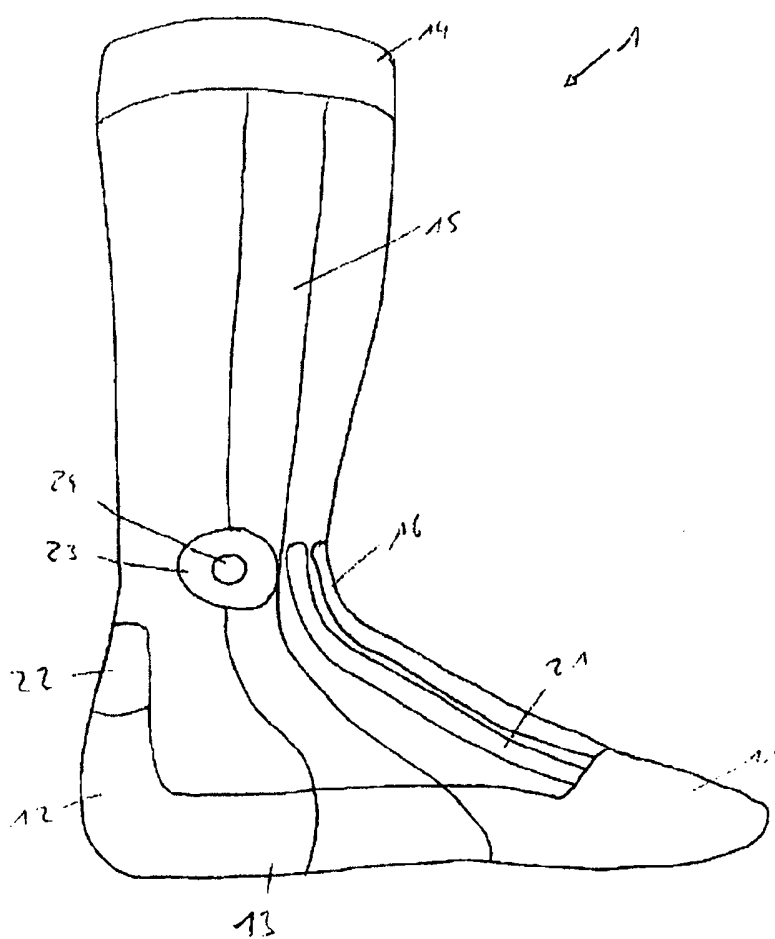

Sock

The invention relates to a sock, in particular for use during sports, said sock comprising cushioned sections.

When humans move a lot and rapidly, in particular, for example, during sports, their feet are held in sturdy footwear. The purpose of the footwear is, on the one hand, to function as a shock absorber and to hold the foot firmly, and, on the other hand, to prevent injuries caused the sole of the foot as a result of stepping on sharp protrusions or objects on the ground.

The body heats up considerably during movement. For heat regulation, the body excretes perspiration to achieve a cooling effect due to cold from evaporation. However, inside the footwear, such evaporation is inhibited. This leads, among other effects, to considerable warming of the foot inside the footwear, to which the body reacts by further increasing the perspiration. The increase in perspiration in socks that are worn in the shoes leads to the entire foot becoming humid, and softening of the skin. As a result, the protective effect of the horny layer of the foot is reduced, and there is an increase in blister formation. The foot is no longer capable of bearing a load.

To promote the evaporation of the perspiration that has formed in the footwear, shoes are provided with a membrane fabric. However, it has been found that not enough of the humid environment can be removed in this way from the interior of the shoe. In addition, the use of membrane surfaces is possible only to a limited extent, because excess use would affect the stability of the footwear.

This is the problem the invention proposes to solve. The invention is based on the problem of producing a sock which allows sufficient environmental control inside the shoe, and thus ensures a dry foot skin even during sports activities. According to the invention, this problem is solved by arranging a ventilation channel on the back of the foot.

The invention produces a sock which allows sufficient ventilation control of the shoe and thus ensures a dry foot skin even during sports activities. When the foot rolls from heel to toe, there is an alternation of excess pressure and low pressure between the back of the foot and the tongue, which promotes air exchange through the ventilation channel.

The ventilation channel is provided advantageously between at least two mutually parallel cushioned sections. As a result, the gap height with respect to the surrounding shoe is increased, which improves the air circulation and thus the evaporation of humidity.

The cushioned sections preferably form bulges on both sides of the tongue of the shoe upper, so that the ventilation channel is positioned directly under the tongue. As a result, an optimal air exchange through the ventilation channel is ensured. It is advantageous for the ventilation channel to be designed as a flat mesh fabric, preferably Jacquard fabric.

In an embodiment of the invention, an air gap is formed in the rest position between the ventilation channel of the sock and the tongue of a shoe. As a result, the excess and low pressure effect caused by the foot rolling from heel to toe is reinforced.

In another embodiment of the invention, a ventilation channel is provided on the internal and/or external side of the sock, extending from the stepping surface to the collar of the sock. As a result, the excess and low pressure effect, which can also be observed to a lesser extent on the side of the footwear as the foot rolls from heel to toe, is used to remove humid air from the shoe. The result is a further increase in the ventilation control in the shoe.

In a variant of the invention, the longitudinal sides of the ventilation channel are interconnected by means of at least one band, which is diagonal with respect to the stepping surface. The result is that the position of the ventilation channel on the back of the foot is fixed, and any folding of the sock on the back of the foot is prevented. The band
5 tightly fixes the ventilation channel on the back of the foot. As a result, the middle portion of the foot is also supported. The band is made preferably of elasthane.

In a preferred variant of the invention, the ventilation channel extends over the entire surface of the back of the foot. The effect of this arrangement is an optimal
10 dehumidification of the back of the foot.

According to one aspect the present invention provides a sock, particularly for use during sports, which includes cushioned sections and a ventilation channel which is arranged on the dorsum of the foot characterized in that between ventilation channel of the sock and the
15 tongue of a shoe, an air gap forms in the rest position.

Other variants and embodiments of the invention are indicated in the dependent claim.

An embodiment of the invention is represented in the drawings and described below in detail. In the drawing:

20 Figure 1 shows the representation of a sock in a side view;

Figure 2 shows the simplified representation of a shoe in a side view;

Figure 3 shows the sock represented in Figure [sic] in combination with the shoe represented in Figure 2;

25 Figure 4 shows the cross section along line IV in Figure 3 in an enlarged representation, and

Figure 5 shows the representation of a sock in a side view in another embodiment;

Figure 6 shows the representation of the sock from Figure 5 in the top view, and

Figure 7 shows the representation of a sock pair in the view from below.

The sock, which bears the general reference numeral 1, presents a toe area 11, a
30 heel area 12, and a stepping surface 13 located between the toe area and the heel area. The areas 11, 12

and 13, as represented in the embodiment example according to Figures 1 and 3, can be manufactured for cushioning from reinforced material. It is also possible to use combinations of materials, such as, for example, virgin wool with elastofiber materials, such as, elastane.

The foot part of the sock transitions into a shaft area, which extends over the calf, in the embodiment example according to Figures 1 and 3. It is also possible for the sock to end above or below for cushioning the ankle. At the end which is turned away from the foot part, the shaft is provided with a collar 14. In the embodiment example, a ventilation channel 15 starts from the collar 14, and extends into the stepping surface 13; it is formed from a ventilation regulating woven mesh fabric. The ventilation channel 15 contributes to moving the humidity upward and out of the stepping surface. Such a ventilation channel 15 can be provided on the inner side of the leg, on the outer side of the leg, or on both sides of the sock.

On the back of the foot 17 of the sock, a ventilation channel labeled 16 is also provided. The ventilation channel 16 extends from the toe area 11 to above the foot joint. The ventilation channel can be extended to the collar 14 of the sock 1. This extension increases the effect of the ventilation channel 16. The ventilation channel 16 is produced from a very flat fabric, for example, a woven mesh fabric or a Jacquard fabric. The result is the formation of an offset between the ventilation channel 16 and the adjacent areas.

In the embodiment example, spacer cushion pads 21 are provided additionally on both sides of the ventilation channel 16 on the back of the foot 17 of the sock 1. The spacer cushion pads 21 form bulges and extend from the toe area 11 to the foot joint. The spacer cushion pads 21 are made from a material that is thicker than the material used for the front part of the foot; particularly in comparison to the ventilation channel 16 which is formed from a very flat ventilation-regulating woven mesh fabric.

The sock 1 is provided, for example, with additional cushion pads 2. In the embodiment example according to Figure 1, a spacer cushion pad 22 is arranged in the area of the heel on the sock 1. Here, the shape of the spacer cushion pad 22 is adapted to the anatomy of the foot in this area. Furthermore, in the area of the ankle, i.e., in the transitional area between the foot part and the shaft of the sock, a cushion pad 23 is provided which presents a substantially annular design. The annular cushion pad 23 encloses a substantially circular surface 24. The cushion pad 23 is designed so that it protrudes clearly over the surface 24.

The cushion pads 2 are made generally of plastic yarns, compound fabrics or compound yarns, or similar materials. In the embodiment example, the cushioned sections 2 of the sock 1 are made of hollow-chamber fibers, around which wool or cotton is spun. Hollow-chamber plastic yarns are particularly strong shock and pressure absorbers. The stepping surface 13 can be made from a microfiber woven material, which helps reduce abrasion. In the toe and heel areas 11, 12, the footbed is made of microfiber fabrics, depending on the requirement.

On both sides of the ventilation channel 16, in the embodiment example according to Figures 5-7, six bands 18 are provided in each case, which extend, starting from the spacer cushion pads 21, through the stepping surface 13, and are connected to the facing side of the ventilation channel 16. If, in deviation from the embodiment example, no spacer cushion pads 21 are provided as lateral delimitation of the ventilation channel 16, the bands 18 start immediately from one side of the ventilation channel 16, and they end, after looping around the stepping surface 13, on the other side of the ventilation channel 16. In the embodiment example, two mutually parallel elasthane bands 18 are arranged in each case on the external sides, and in the middle, of the ventilation channel 16. As a result, the ventilation channel 16 is stretched evenly over the back of the foot 17.

The shoe, which is represented in the embodiment example according to Figure 2 and which bears the general reference numeral 3, has a sole 31 on which a closed upper 32 is arranged. When the shoe is worn (Figure 3), the wearer's foot is supported by the sole 31, while the remaining part of the foot, up to the ankle, is surrounded by the upper 32. The upper 32 can be made of different materials. While in the past leather was used predominantly as material for the upper 32, plastic fibers and plastics are used predominantly today.

The upper 32 of the shoe 3 has a tongue 33 over which are situated laces (not shown) for tying the shoe. For this purpose, the shoe is provided with eyelets 34. The tongue 33 is provided with padding to prevent foot pain when the user ties the shoe tightly, or in case of a heavy load. On the sides of the shoe 3, ventilation zones 35 are provided, which, as a function of the intended use of the shoe, are provided at different places and in different shapes and sizes. The ventilation zones 35 are made of a membrane fabric.

The effect of the special arrangement of the spacer cushion pads 21 and the ventilation channel 16 is explained below in reference to Figures 3 and 4: In the rest position, because of the different thickness of the ventilation channel 16, an air gap 4 with respect to the adjacent fabric of the sock 1 and of the tongue 33 of the shoe 3 is formed. This effect is reinforced by the spacer cushion pad 21 which is provided in the embodiment example. The bands 18 also have the effect that the ventilation channel 16 is stretched evenly on the back of the foot, which prevents folding, for example.

While the foot rolls from heel to toe, the ventilation channel 16 is pressed against the tongue 33, which generates excess pressure in this area. The excess pressure causes an accelerated removal of the humid air through the ventilation channel 16 to the exterior. When the foot returns to its rest position, the air gap 4 between the ventilation channel 16 and the tongue

33 forms again, generating a low pressure in this area. As a result of the low pressure, dry external air is now transported through the ventilation channel 16 into the interior of the shoe. This alternation between excess pressure and low pressure between the tongue 33 and the ventilation channel 16 occurs continuously during running, and thus leads to optimal ventilation control in the interior of the shoe.

A similar effect can be achieved on the internal side and the external side, respectively, of the shoe. During running, the separation between the shoe upper 32 and the foot changes continuously so that in this area as well a pumping effect is achieved, although it is slight. This pumping effect can be used to improve the ventilation control inside the shoe by means of a ventilation channel 15, which is arranged on the side of the sock 1, and which extends from the stepping surface 13 of the sock to above the foot joint.

Throughout this specification and the claims which follow, unless the context requires otherwise, the word "comprise", and variations such as "comprises" or "comprising", will be understood to imply the inclusion of a stated integer or step or group of integers or steps but not the exclusion of any other integer or step or group of integers or steps.

The reference in this specification to any prior publication (or information derived from it), or to any matter which is known, is not, and should not be taken as, an acknowledgement or admission or any form of suggestion that that prior publication (or information derived from it) or known matter forms part of the common general knowledge in the field of endeavour to which this specification relates.

The Claims defining the invention are as follows:

1. Sock, particularly for use during sports, which includes cushioned sections and a ventilation channel which is arranged on the dorsum of the foot characterized in that
5 between the ventilation channel of the sock and the tongue of a shoe, an air gap forms in the rest position.
2. Sock according to Claim 1, characterized in that the ventilation channel is provided between at least two mutually parallel cushioned sections.
10
3. Sock according to Claim 1 or 2, characterized in that the cushioned sections form bulges on both sides of the tongue of the upper of a shoe, so that the ventilation channel is positioned directly under the tongue.
- 15 4. Sock according to any one of Claims 1 to 3, characterized in that the ventilation channel is formed from a flat mesh fabric, preferably a Jacquard fabric.
5. Sock according to any one of the preceding claims, characterized in that the cushion pads are made of hollow-chamber fibers, around which wool or cotton is spun.
20
6. Sock according to any one of the preceding claims, characterized in that, in the area of the ankle, an annular cushion pad is provided, which encloses a circular surface.
7. Sock according to any one of the preceding claims, characterized in that the
25 longitudinal sides of the ventilation channel are interconnected by at least one band, which is diagonal with respect to the stepping surface.
8. Sock according to claim 7, characterized in that the band is made of elasthane.

- 13 -

9. Sock according to any one of the preceding claims, characterized in that the ventilation channel extends over the entire surface of the back of the foot.

10. A sock substantially as herein described with reference to the accompanying
5 figures.

2006256924 24 Nov 2011

Fig. 1

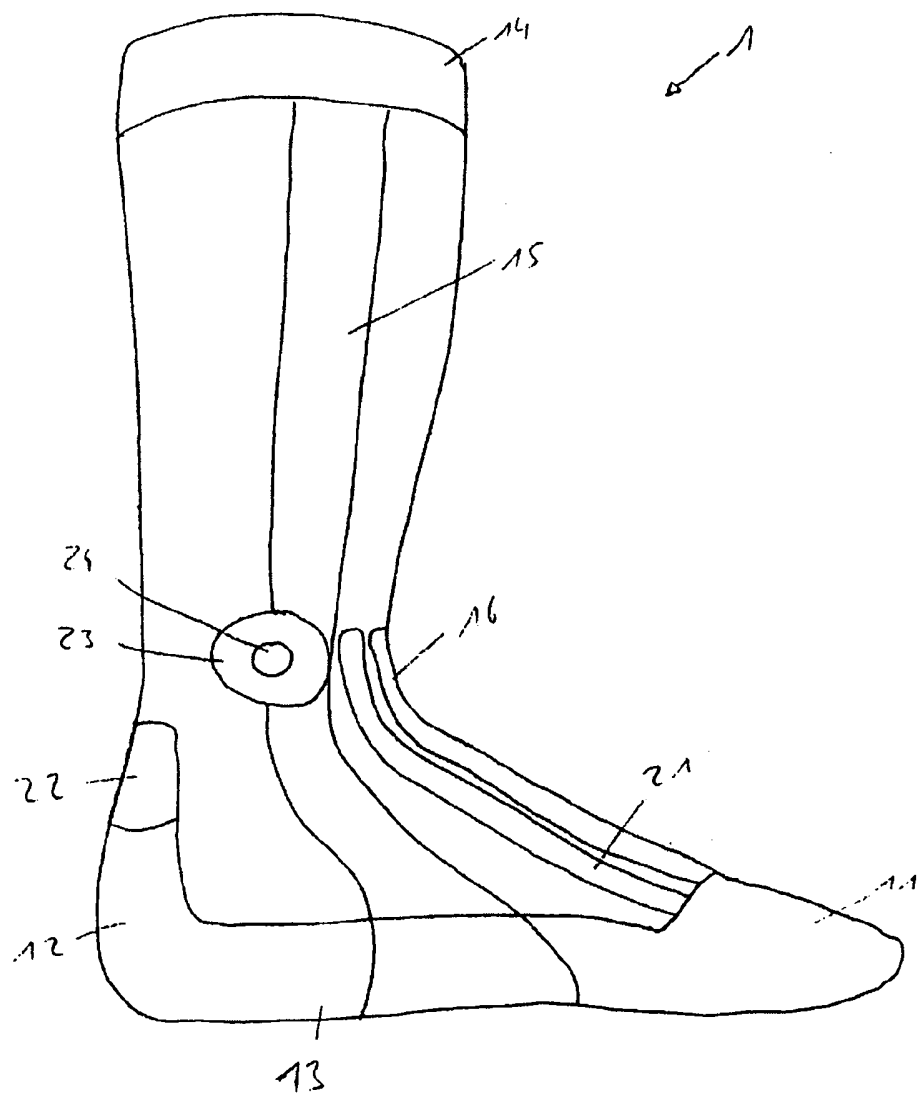

Fig. 2

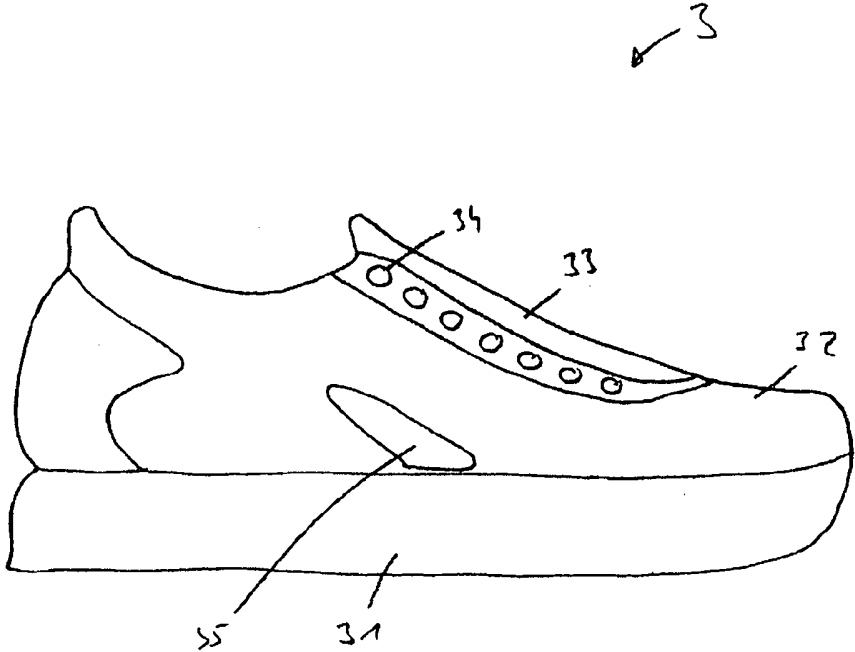

Fig. 3

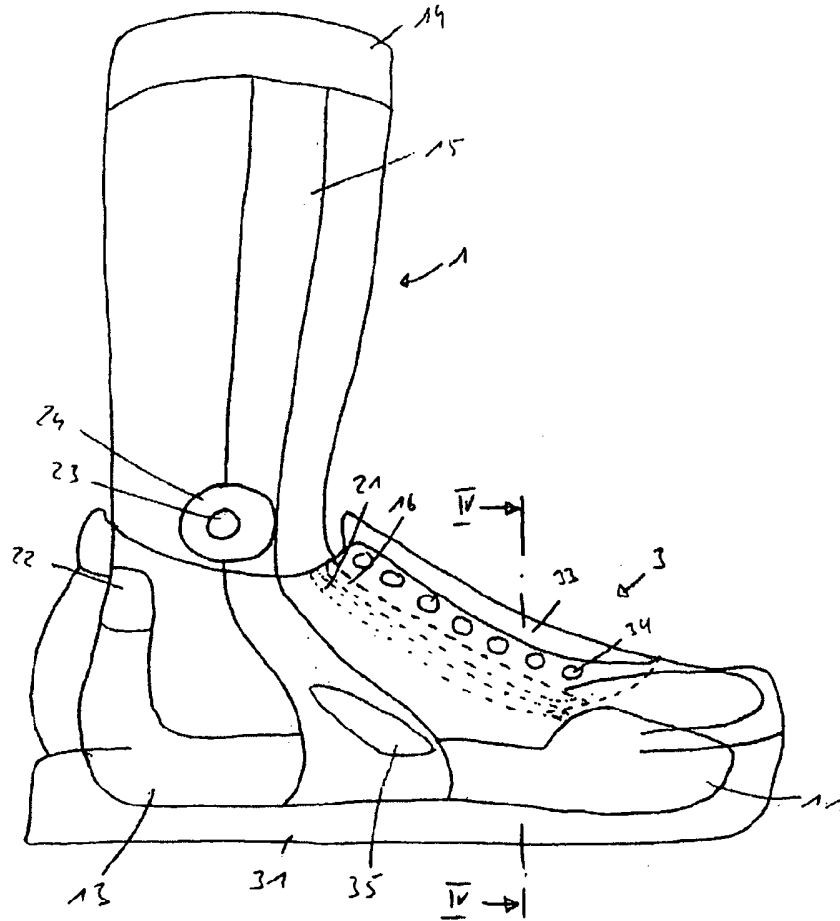

Fig. 4

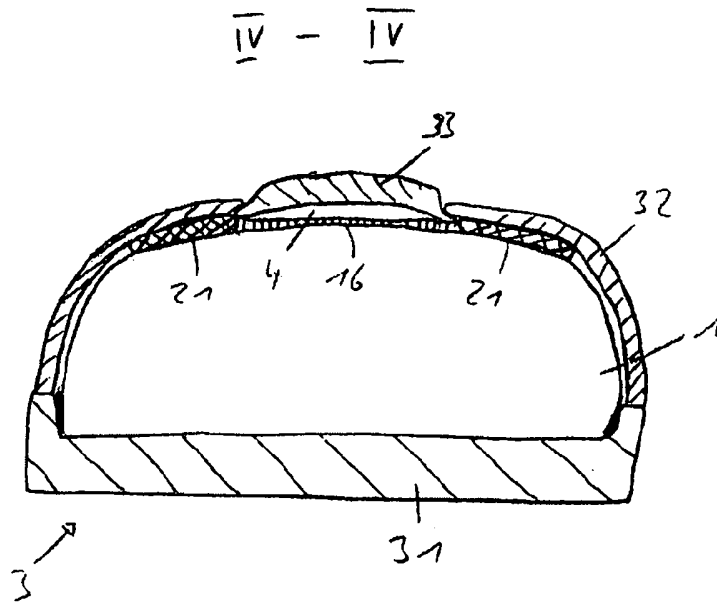

Fig. 5

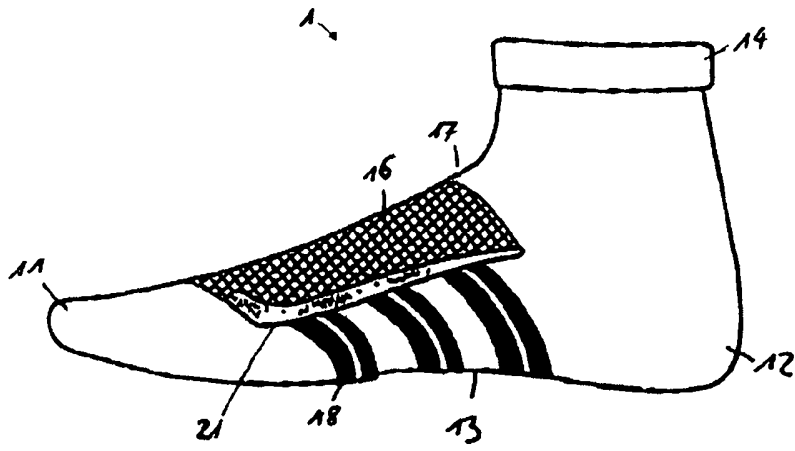

Fig 6

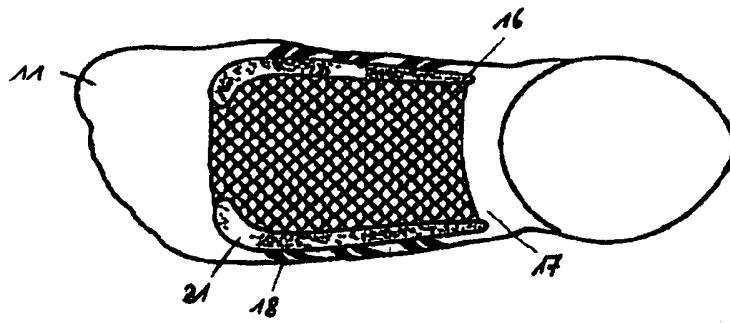

Fig. 7

