

No. 686,151.

Patented Nov. 5, 1901.

J. W. SIMONS.

HEMMING AND HEMSTITCHING ATTACHMENT.

(Application filed Apr. 16, 1901.)

(No Model.)

2 Sheets—Sheet I.

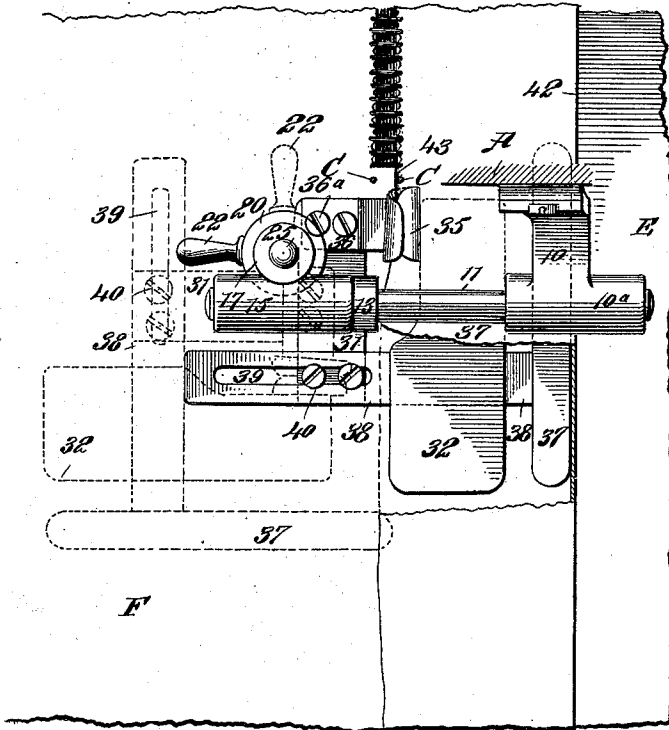

Fig. 1.

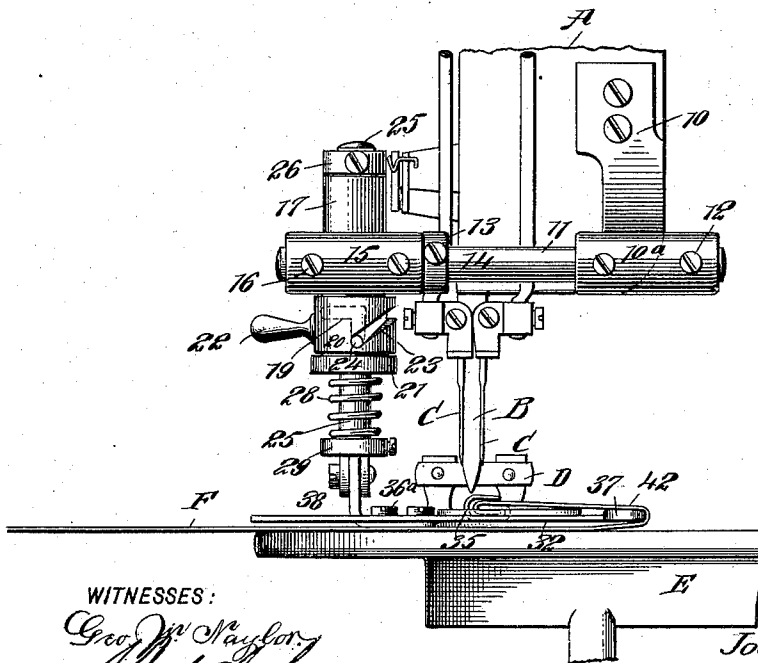

Fig. 2.

WITNESSES:

Geo. W. Naylor
Ed. H. Keen

INVENTOR

Joseph W. Simons

BY

Munn
 ATTORNEYS

No. 686,151.

Patented Nov. 5, 1901.

J. W. SIMONS.

HEMMING AND HEMSTITCHING ATTACHMENT.

(Application filed Apr. 16, 1901.)

(No Model.)

2 Sheets—Sheet 2.

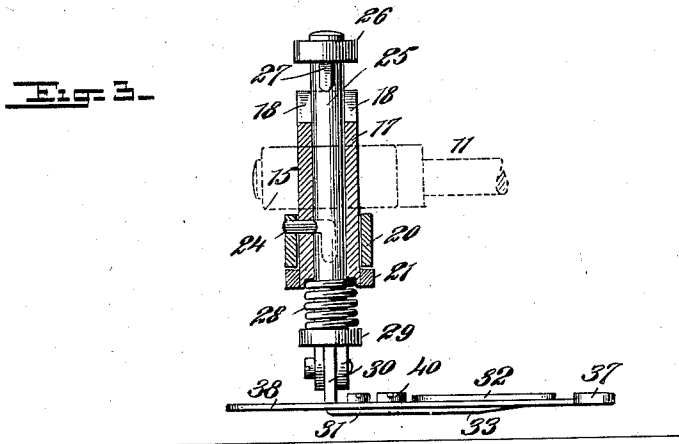

Fig. 4.

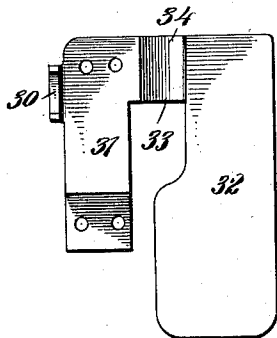

Fig. 5.

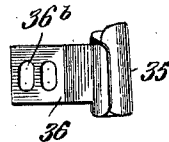
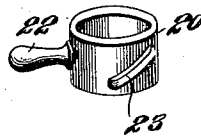

Fig. 6.



WITNESSES:

Geo. W. Taylor
J. H. [Signature]

INVENTOR

Joseph W. Simons

BY

Wm. [Signature]
 ATTORNEYS

UNITED STATES PATENT OFFICE.

JOSEPH W. SIMONS, OF PORTCHESTER, NEW YORK.

HEMMING AND HEMSTITCHING ATTACHMENT.

SPECIFICATION forming part of Letters Patent No. 686,151, dated November 5, 1901.

Application filed April 16, 1901. Serial No. 56,072. (No model.)

To all whom it may concern:

Be it known that I, JOSEPH W. SIMONS, a citizen of the United States, and a resident of Portchester, in the county of Westchester and State of New York, have invented a new and Improved Hemming and Hemstitching Attachment, of which the following is a full, clear, and exact description.

My invention relates to a hemming and hemstitching attachment for sewing-machines.

The purpose of the invention is to fold or lay a hem of any desired width to the line where the threads are drawn and to stitch or fasten the hem down as the hemstitch is made. Heretofore it has been necessary to crease and baste the hem down first in order to bring the hem to a line with the drawn threads and to have the ends of the hem even when the operation of hemming is accomplished. The improved device dispenses with the operation of creasing and basting and produces more perfect work.

Another purpose of the invention is to provide an open device of the character described which avoids any resistance or friction on the material. The feed coming against the under side of the material in the ordinary hemstitching attachments carries the lower portion of the hem along faster than the upper or turn edge can do it for the upper portion of the hem; and one of the purposes of this invention is to overcome this defect by means of a plate or bridge which will permit the operator to help the upper edge of the material along and cause the said upper edge to naturally come out even with the under edge and, furthermore, to insure the edge of the hem being properly turned over in the turning device.

In circular articles—such as pillow-cases, skirts, and the like—the purpose of the invention is to provide means for turning the fold-gage from within the fold or hem, and in accordance with such construction the operator may start at any point on the garment and continue around to a point about the width of the hem from the starting-point. At this time the fold-gage is turned out of the hem or fold, and the work being left in a straight line can be finished with ease.

Another purpose of the invention is to so construct the attachment that it may be used

to great advantage on work where there are to be two or more rows of hemstitching.

The invention consists in the novel construction and combination of the several parts, as will be hereinafter fully set forth, and pointed out in the claims.

Reference is to be had to the accompanying drawings, forming a part of this specification, in which similar characters of reference indicate corresponding parts in all the figures.

Figure 1 is a plan view of the attachment shown in two positions—namely, the fold-gage and table within the hem and the fold-gage and table withdrawn from the hem. Fig. 2 is a front elevation of the attachment, illustrating it applied to the head of a hemstitch sewing-machine. Fig. 3 is a vertical section through the shifting member of the attachment and an edge view of the bed portion of the attachment. Fig. 4 is a plan view of the table by means of which the upper feed is accelerated and a branch from the table which is adapted to carry the edge-turner and with which the fold-gage is adjustably connected. Fig. 5 is a perspective view of the edge-turner, and Fig. 6 is a perspective view of the sleeve which is actively employed for operating the shifting member of the attachment.

In the drawings I have illustrated the attachment applied to the head A of a hemstitch sewing-machine. B represents the spear, which forms the openings between the stitches in the hemstitch. C represents the two needles which act in connection with the spear. D represents the double presser-foot common to such class of machines, and E represents the table of the machine.

The attachment consists of an arm 10, which is adapted to be connected to the head A of the sewing-machine, as is shown in Figs. 1 and 2, the said arm 10 being provided at its lower end with a horizontal sleeve 10^a, through which one end of a horizontal shaft 11 is passed, and the shaft is held in the sleeve 10^a by means of set-screws 12 or their equivalents. A collar 13, provided with a set-screw 14, is mounted to slide on the shaft 11 between the sleeve 10^a and a horizontal sleeve 15, provided likewise with set-screws 16, which sleeve 15 is secured to an upright tubular casing 17. (Shown best in Figs. 2 and 3.) This tubular casing 17 is provided at its up-

per end with vertical slots 18 in opposite sides, and between the center and bottom of the tubular casing 17 a bayonet-slot 19 is produced in the said casing, as is shown in dotted lines in Fig. 2. A collar 20 is mounted to turn on the casing 17 at that portion where the bayonet-slot 19 is produced, as is shown in Figs. 2 and 3, and this collar 20 (shown in detail in Fig. 6) is held in place on the casing by a ring 21 or its equivalent secured to the bottom portion of the casing. The said collar is provided with a handle 22, by means of which the collar is turned, and, furthermore, the collar is provided with an inclined slot 23. A pin 24 extends out through the bayonet-slot 19 in the casing 17 and through the slot 23 in the collar, the said pin being secured to a rod 25, which has vertical movement in the casing 17. This rod is provided at its upper end with a cap 26, either attached thereto or made integral therewith, and below the cap opposing vertical lugs 27 are formed on the rod, which lugs are adapted for engagement either with the upper edge of the casing 17 or are adapted to enter the slots 18 in the top of the casing.

When the lugs 27 engage with the top of the casing 17, a spring 28 is placed under compression, which spring is coiled around the bottom portion of the rod or bar 25 and has bearing against the bottom of the casing 17 and against an offset 29, produced upon or attached to the said rod or bar at a point below the casing 17.

In the construction of the base portion of the attachment a vertical arm 30 is secured in any approved manner, preferably in a detachable manner, to the lower end of the bar or rod 25, and this vertical arm 30 extends up from the outer longitudinal edge of a base-plate 31. Practically parallel with this base-plate 31 is located a table 32, connected at one end with one end of the base-plate 31 by a connecting member 33, provided, preferably, with a transverse depression 34 in its upper face, as is best shown in Fig. 4. This table 32 is preferably made of greater width at its inner end, or the end which faces the operator, than at its forward or outer end, or that end which is connected with the base-plate 31. The depression 34 is adapted to receive an edge-turner 35 of any approved construction, provided with a shank 36, which shank is secured by screws 36^a or their equivalents to the upper face of the forward portion of the base-plate 31, as is shown best in Fig. 1. This edge-turner is adjustably attached, since the set-screws 36^a pass through elongated slots 36^b in the shank of the edge-turner, as is illustrated in Fig. 5.

A fold-gage 37 extends parallel with the longitudinal edge of the table 32; but the fold-gage 37 is spaced from the said table, as is illustrated in Figs. 1, 2, and 3. This fold-gage near its forward end is attached to an arm 38, provided with a longitudinal slot 39, and the slotted end of the arm 38 is passed

across the upper face of the forward end of the base-plate 31. Set-screws 40 are passed through the slot 39 into suitably-threaded apertures made in the base-plate 31, as is shown in Figs. 1 and 4. Thus it will be observed that the arm 38, carrying the fold-gage 37, renders the said gage adjustable, and the said arm passes beneath the table 32.

The material F in which the hemstitched hem is to be produced is passed beneath the base portion of the attachment, and the edge of the material is carried over the fold-gage 37, as is shown in Fig. 2, and the rear edge of the hem or fold thus formed is made to enter the edge-turner 35, said material being provided with a drawn-thread section 43, up to which line the fold is carried. When the material is being placed in position, the collar 20 is turned by moving the handle 22, and the bar or rod 25 is carried to the upper position (shown in Fig. 3) and is swung out from the needles. After the adjustment of the material has been made the collar 20 is restored to its normal position, thus carrying the base of the device to the position shown in positive lines in Fig. 1 and in such position that the material can be acted upon by the spear and the needles of the machine; but the material may be adjusted on the attachment while said attachment is in its normal position.

In circular work after the hem has been stitched to a point near its commencement the collar 20 is manipulated to raise the rod or bar 25 and carry the fold-gage and table out from the hem or fold of the material, leaving but a short straight section of the hem to be finished in the usual way. When the attachment is carried out from the hem or fold, it occupies the position shown in dotted lines in Fig. 1.

The table 32 is of great importance. In operation it lies within the hem or fold, and as the feed at the under face of the material is necessarily greater than that at the top or where the material passes through the edge-turner in order that the ends of the hem shall be even throughout the work by placing a hand on the material over the table the operator may not only assist in the forward feed of the material, but is also enabled to effectually guide the material into or through the edge-turner.

The collar 13, mounted on the shaft 11, is for the purpose of locating the adjustment of the sleeve 15 on the shaft, so that when the attachment is not needed the sleeve 15 may be removed from said shaft and when again required will occupy the same position on the shaft which it occupied when removed.

Having thus described my invention, I claim as new and desire to secure by Letters Patent—

1. In a hemming and hemstitching attachment for sewing-machines, a hand-feed table adapted to enter the hem, an edge-turner at one side of the forward end of the table, and

a fold-gage arranged parallel with one longitudinal edge of the table, and extending throughout the length of the same, said gage being also adapted to enter the hem, as set forth.

2. In a hemming and hemstitching attachment for sewing-machines, a movable support, a hand-feed table carried by the support and adapted to enter the hem, a fold-gage also carried by the support and adapted to extend into the hem, said gage being arranged parallel with one longitudinal edge of the table and extending throughout the length of the same, an edge-turner carried by the support at one side of the forward portion of the table, and means whereby the said support may be moved to bring the parts carried thereby into operative position, as set forth.

3. A hemming and hemstitching attachment for sewing-machines, comprising a base-plate, mounted to rotate about a vertical axis, a table connected with the base-plate, an adjustable fold-gage carried by the base-plate parallel therewith, and an edge-turner carried by the base-plate and located between the table and base-plate.

4. In a hemming and hemstitching attachment for sewing-machines, a sliding and swinging support, a base-plate carried by the support, a fold-gage adjustably attached to the base-plate, a hand-feed table carried by the base-plate and located between the said plate and the fold-gage, and an edge-turner located between the hand-feed table and the base-plate, as described.

5. In a hemming and hemstitching attachment for sewing-machines, a hand-feed table, an edge-turner at one side of the table, a fold-gage arranged parallel with one longitudinal edge of the table and adjustable toward and from the same, the table and gage both being adapted to enter the hem to be stitched, and a support for the table, edge-turner and gage, said support being mounted to rotate about a vertical axis, as set forth.

6. In a hemming and hemstitching attachment for sewing-machines, a base-plate, a table parallel with the base-plate and connected therewith at one end by a connecting member having a transverse depression, and an edge-turner secured to the base-plate and located in the depression of the said connecting member, as set forth.

7. In a hemming and hemstitching attachment for sewing-machines, a base-plate, a ta-

ble secured at one end to the base-plate by a connecting member having a transverse depression, said table extending parallel with the base-plate, an edge-turner adjustably secured to the base-plate and arranged in the depression of the connecting member, and a fold-gage adjustably secured to the base-plate and extending parallel with the table, as set forth.

8. In a hemming and hemstitching attachment for sewing-machines, the combination with an edge-turner, and a fold-gage, of a casing adapted to be secured to the sewing-machine head, a rod mounted to slide and turn in the said casing, said rod carrying the edge-turner and gage, and means for operating said rod, as set forth.

9. In a hemming and hemstitching attachment for sewing-machines, the combination with an edge-turner, and a fold-gage, of a casing adapted to be secured to the sewing-machine head and provided with a bayonet-slot, a rod loosely mounted in the casing and carrying the edge-turner and gage, a collar mounted to turn on the casing and provided with an inclined slot, and a pin secured to the rod and working in the bayonet-slot of the casing and inclined slot of the collar, as set forth.

10. In a hemming and hemstitching attachment for sewing-machines, a base-plate, a table secured to the base-plate at one end by a connecting member and extending parallel with the base-plate, an edge-turner secured to the member connecting the table with the base-plate and a fold-gage adjustably secured to the base-plate and extending parallel with the table, as set forth.

11. In a hemming and hemstitching attachment, a base-plate having a laterally-projecting member at one end, said member having a transverse depression, a table secured to the lateral member of the base-plate and extending parallel with the base-plate, an edge-turner secured in the depression of the lateral member of the base-plate, and a fold-gage adjustably secured to the base-plate and extending parallel therewith, as set forth.

In testimony whereof I have signed my name to this specification in the presence of two subscribing witnesses.

JOSEPH W. SIMONS.

Witnesses:

HARRY S. CARPENTER,
EDWARD W. SIMONS.