



(12) **EUROPEAN PATENT APPLICATION**

(43) Date of publication: **21.07.2004 Bulletin 2004/30** (51) Int Cl.7: **B65D 90/04, B65D 90/34**

(21) Application number: **04250201.3**

(22) Date of filing: **16.01.2004**

(84) Designated Contracting States:
**AT BE BG CH CY CZ DE DK EE ES FI FR GB GR
 HU IE IT LI LU MC NL PT RO SE SI SK TR**
 Designated Extension States:
AL LT LV MK

(72) Inventors:
 • **Dudding, Sheron Leslie**
Broomfield East Yorkshire HU15 1RR (GB)
 • **Massie, Michael Peter Douglas**
North Ferriby East Yorkshire HU14 3BX (GB)

(30) Priority: **16.01.2003 GB 0300933**

(74) Representative: **W.P. Thompson & Co.**
Coopers Building
Church Street
Liverpool L1 3AB (GB)

(71) Applicant: **Linertech Limited**
Elland, West Yorkshire HX5 9BX (GB)

(54) **A liner for bulk cargo containers**

(57) The discharge end of rear end of a bulk liner (10) for an ISO container has a discharge sleeve (not visible) located behind a triangular flap (12). The bottom edge of the flap (12) extends under the liner (10) for a distance and is secured thereto by welding or by adhesive tape. The apex of the flap (12) covering the discharge

sleeve is secured to the inside of the container so as to lift the adjacent edge of the floor of the liner and place the flap under tension. The flap supports and retains the weight of the product within the liner as the discharge hatch is opened, thereby preventing bulging of the liner which would otherwise prevent the discharge hatch from being closed.

BACK (DISCHARGE) END

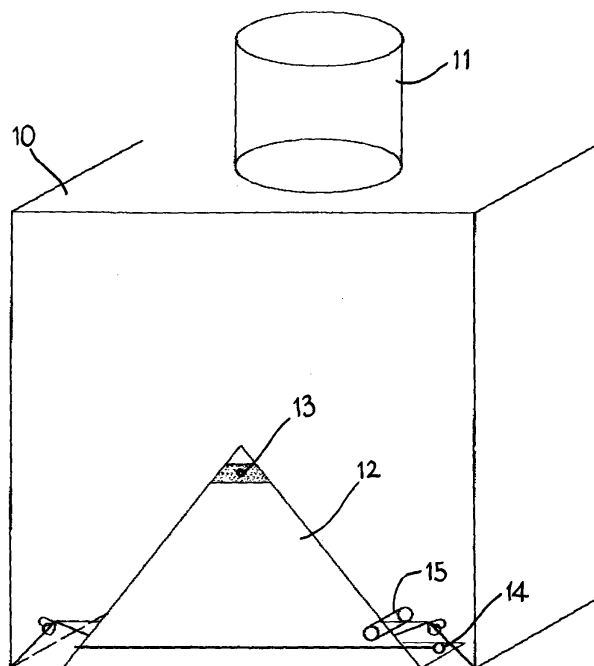

Fig. 1

Description

[0001] This invention relates to improvements to a flexible liner for an 'ISO container.

[0002] ISO containers specially adapted for the carriage of bulk cargo are well known, and generally comprise a large rectangular prismatic shaped container specifically designed in modular sizes to fit on road trailers, rail trucks and container-carrying ships. The top of the container will generally incorporate one or more hatches to facilitate filling of the container, and some form of hatch in the lower part of one end to allow discharge of the product. The product is most commonly discharged by tipping the whole container, so that it flows out through the hatch into a hopper, rotary valve or other means by which it is transported to a silo or other receptacle.

[0003] When such containers are filled with bulk cargoes, it is common to fit a liner made from a flexible film or material inside the container. This encapsulates the product and isolates it from the container, thereby preventing contamination of the container by the product, or contamination of the product by moisture ingress, residues already in the container or from other sources.

[0004] The liner is usually fitted with filling sleeves located to match the positions of the hatches at the top of the container, and a hanging system to suspend it within the container. The liner also incorporates a discharge sleeve which is situated behind the discharge hatch. This discharge sleeve is commonly of triangular or fish-tail shape, and is folded so that when the hatch is opened, it may be unfolded and used to direct the contents into a suitable receptacle.

[0005] When the liner is filled, the filling sleeves are tied off, or closed in other suitable fashion, and documents relating to the consignment are commonly put into a pouch attached to the top of the liner before the hatches are closed and transport seals fitted to all doors and hatches.

[0006] When the loaded container has been transported to the delivery point, it has been the practice to climb onto the top of the container and open one or more hatches, both to recover the documentation from the document pouch, and to open one or more filling sleeves to permit the ingress of air to replace the product as it is discharged. It is furthermore common practice for the customer to require a sample for testing, and this is also taken through the top filling sleeves.

[0007] All the foregoing operations on the top of the container carry some measure of risk, both to the operator who climbs onto the top in what may be icy or wet conditions, and to the product which could be contaminated by the ingress of pollutants through the opened filling sleeve.

[0008] It has been proposed that the document pouch should be sited under the discharge hatch, so that the operative does not need to climb onto the top of the container, and also that the sample should be taken from

around the discharge area for the same reasons. However, if the discharge hatch is opened after the container has been filled, the pressure of the product within the liner will make it bulge out through the hatch aperture, thereby preventing subsequent closure of the hatch, either for subsequent sealing and transport, or to await the results of sample checking.

[0009] According to the present invention there is provided a liner for a bulk cargo container having a cargo discharge hatch, the liner comprising support means in the region corresponding to the discharge hatch to prevent bulging of the liner through the discharge hatch.

[0010] By preventing the liner from bulging through the discharge hatch it is possible for pre-discharge requirements to be met without the driver or operator needing to go on top of the container. In particular, documentation relating to the content of the liner can be kept in a pouch behind the discharge hatch for inspection because the discharge hatch can be easily closed again. It is also possible to discharge the contents of the liner without it being necessary to open the filling sleeves to permit ingress of air, and to take samples of the content of the liner through the discharge hatch.

[0011] Preferably, the support means is movable from a first position in which it supports, and prevents bulging of the liner to a second a position in which the liner is not supported.

[0012] Preferably, the support means for preventing bulging of the liner comprises a flap formed from a sheet of strong flexible material which is preferably adapted to be anchored along one edge between the lower face or floor of the liner and the container floor, and which is also preferably adapted to be secured to the container body at a point or points above the discharge hatch.

[0013] The liner may further comprise a discharge sleeve which is normally covered by the flap.

[0014] In a preferred embodiment of the present invention the flap is attached to the liner itself. By virtue of the edge of the flap being attached to the floor of the liner, the edge is trapped and secured in place under the weight of the liner when filled. Conveniently, the edge of the flap is attached to the floor of the liner by adhesive tape or similar, but it will be appreciated that other attachment means may be employed. However, the flap may be attached to the floor of the container and/or it may be of sufficient length to extend under the liner whereby the weight of the filled liner acts on the flap, thereby ensuring that it is trapped by the weight of the liner when filled.

[0015] With the edge of the flap firmly secured to the floor of the liner it can be pulled up to cover that part of the liner which lies behind the discharge hatch and anchored in position to the container body so as to be taut enough to prevent bulging of the liner and the discharge sleeve, if present. Conveniently, the flap may be anchored to the container using hooks or similar devices already provided in the container for the purpose of hanging the liner, or purposely designed anchor points

can be provided in the container. Where the container anchors take the form of hooks, reinforced eyelets may be provided in the sheet which can be positioned over the hooks.

[0016] Preferably, the flap is anchored prior to filling the liner and is anchored in such a way as to lift the front edge of the floor of the liner from the floor of the container, thus ensuring that as the liner is filled the sheet is tautened.

[0017] The sheet preferably comprises a material which is not prone to stretching, such as heavy duty polythene or polypropylene. The material may also comprise a reinforced plastics sheet. Conveniently, a rip cord is provided in the sheet which may be used to cut through the sheet when discharging of the liner is to be carried out. Once the sheet has been cut through the discharge sleeve is made accessible. Also, a document pouch may be provided in the sheet.

[0018] In order to facilitate pre-discharge sampling of the contents of the liner a small sleeve may be provided in that part of the liner which is accessible in use through the open discharge hatch. Conveniently, this sleeve is provided in the liner at the side thereof where the liner content is likely to remain quite static. The sleeve is usually closed off to prevent product from leaking out through it, but can be opened to allow a sample of product to be taken, or to admit a test probe. The sampling tube may be positioned to one side of the said sheet or it may pass through a hole in the sheet.

[0019] The flap may extend over the liner so as to substantially fully cover that area of it which is exposed when, in use, the discharge hatch is opened. However, because the product tends to be static along the sides of the liner so that it tends to bulge in the middle, it may conveniently be triangular in shape so as to cover only that part of the liner which is subject to bulging.

[0020] Preferably, a self venting port is provided in the liner which obviates the need for one or more of the filling sleeves to be opened prior to discharge. This conveniently takes the form of an aperture in the wall of the liner which aperture is filled with an air permeable material which admits air, but prevents ingress of dust and other contaminants. This aperture is covered by an impermeable sheet which is folded, pleated or otherwise shaped to form corrugations so that air can be admitted but water or condensation will run off.

[0021] The present invention also includes a liner in accordance with the present invention in combination with a tank container.

[0022] An embodiment of the present invention will now be described, by way of example only, with reference to the accompanying drawings, in which:-

Fig. 1 shows the discharge or rear end of a bulk liner according to the present invention; and
Fig. 2 shows the front end of the bulk liner with the venting aperture therein and covering flap.

[0023] Referring to Fig. 1 there is shown the discharge or rear end of a bulk liner 10 for an ISO container, with filling sleeves 11 and a discharge sleeve (not visible) located towards the bottom thereof, behind a triangular flap 12. The bottom edge of the flap 12 extends under the liner 10 for a distance and is secured thereto by welding or adhesive tape. Towards the apex of the flap 12 is provided a reinforced attachment point consisting of an eyelet 13, which is intended, in use, to be attached to a hook or other fixing inside the container.

[0024] In use the liner 10 is suspended within a container using conventional hangers with the filling sleeves 11 adjacent to the filling hatches therein and the discharge sleeve adjacent to the discharge hatch therein. The apex of the flap 12 covering the discharge sleeve is secured to the inside of the container so as to lift the adjacent edge of the floor of the liner and place the flap under tension. The liner is then filled.

[0025] It will be understood that the triangular flap supports and retains the weight of the product within the liner when the discharge hatch is opened, thereby preventing bulging of the liner which would otherwise prevent the discharge hatch from being closed. Consequently, it is possible to carry out certain operations which would otherwise have to be carried out through the filling hatches. Documentation can be carried on the liner behind the discharge hatch and the product can be sampled through the discharge hatch. To this latter end a sample extraction tube 15 is provided in the liner to one side of the flap 12.

[0026] To facilitate hanging the liner within a container the apex of the flap 12 is attached to the liner by means of welding or adhesive tape.

[0027] A rip cord 14 is provided behind the flap 13 and extends the full width of the flap 13. By pulling on the free end of the rip cord 14 it is possible to cut across the flap 13 to make the discharge sleeve in the liner accessible.

[0028] Referring to Fig. 2 there is shown a venting port provided in the front or forward face of the liner. This venting port comprises an aperture filled with air permeable material 18 and covered by a pleated or corrugated flap 19 of water impermeable material. The flap hangs down over the aperture to prevent water or condensate seeping into the liner, but allows air to pass freely through the pleats therein.

Claims

1. A liner for a bulk cargo container having a cargo discharge hatch, the liner comprising support means in the region corresponding to the discharge hatch to prevent bulging of the liner through the discharge hatch.
2. A liner as claimed in claim 1, wherein the support means is movable from a first position in which it

- prevents bulging of the liner to a second position in which the liner is not supported.
3. A liner as claimed in claim 1 or claim 2, wherein the support means comprises a flap formed from a sheet of flexible material. 5
4. A liner as claimed in claim 3, further comprising a discharge sleeve which, in use, is covered by the flap. 10
5. A liner as claimed in claim 3 or claim 4, wherein the sheet of flexible material is adapted to be anchored along an edge between the lower face or floor of the liner and the floor of the bulk cargo container. 15
6. A liner as claimed in claim 5, further comprising means for securing the flap to the container body at a point or points above the discharge hatch. 20
7. A liner as claimed in any of claims 3 to 6, wherein the flap is attached to the liner.
8. A liner as claimed in claim 7, wherein an edge of the flap is attached to the floor of the liner. 25
9. A liner as claimed in any of claims 3 to 8, wherein the edge of the flap is attached to the floor of the liner by means of adhesive tape. 30
10. A liner as claimed in claim 8 or claim 9, wherein the flap is of sufficient length to extend under the liner whereby the weight of the filled liner acts on the flap.
11. A liner as claimed in any of claims 3 to 10, wherein the flap can be positioned to cover that part of the liner which, in use, lies behind the discharge hatch of the container, the liner further comprising means for anchoring the flap to the container body in a condition sufficiently taut to prevent bulging of the liner. 40
12. A liner as claimed in any of claims 3 to 11, wherein the flap comprises means for releasable connection to an anchor point of a container. 45
13. A liner as claimed in claim 12, wherein the flap comprises a reinforced eyelet.
14. A liner as claimed in any of claim 12 or claim 13, wherein when the flap is secured to an anchor point of the container, the front edge of the floor of the liner is lifted from the floor of the container. 50
15. A liner as claimed in any of claims 3 to 14, wherein the flap comprises a rip cord for severing the flap to allow discharge of the cargo. 55
16. A liner as claimed in any of claims 3 to 15, wherein the flap comprises a document pouch.
17. A liner as claimed in any of claims 3 to 16, wherein the flap extends so as to cover substantially the whole of the area of the liner which is exposed when, in use, the discharge hatch is opened.
18. A liner as claimed in any of claims 3 to 17, wherein the flap is triangular in shape.
19. A liner as claimed in any of claims 3 to 18, wherein the sheet comprises a material which is resistant to stretching.
20. A liner as claimed in claim 19 wherein the sheet comprises polythene.
21. A liner as claimed in claim 20, wherein the sheet comprises heavy duty polythene.
22. A liner as claimed in claim 19, wherein the sheet comprises polypropylene.
23. A liner as claimed in any of claims 19 to 22, wherein the sheet comprises reinforced plastics.
24. A liner as claimed in any of the preceding claims, further comprising a sleeve formed in a part of the liner which is accessible in use through an open discharge hatch of the container.
25. A liner as claimed in claim 24, wherein the sleeve is provided at the side of the liner.
26. A liner as claimed in any of the preceding claims, further comprising a self-venting port.
27. A liner as claimed in claim 26, wherein the self-venting port comprises an aperture in the wall of the liner filled with an air-permeable material.
28. A liner as claimed in claim 27, further comprising a liquid-impermeable sheet located over the air-permeable material.
29. A liner as claimed in claim 28, wherein the liquid-impermeable sheet is folded, pleated or otherwise shaped to form undulations to allow air to reach the air-permeable material but to allow liquid to run off.
30. The combination of a tank container and a liner as claimed in any of the preceding claims.

BACK (DISCHARGE) END

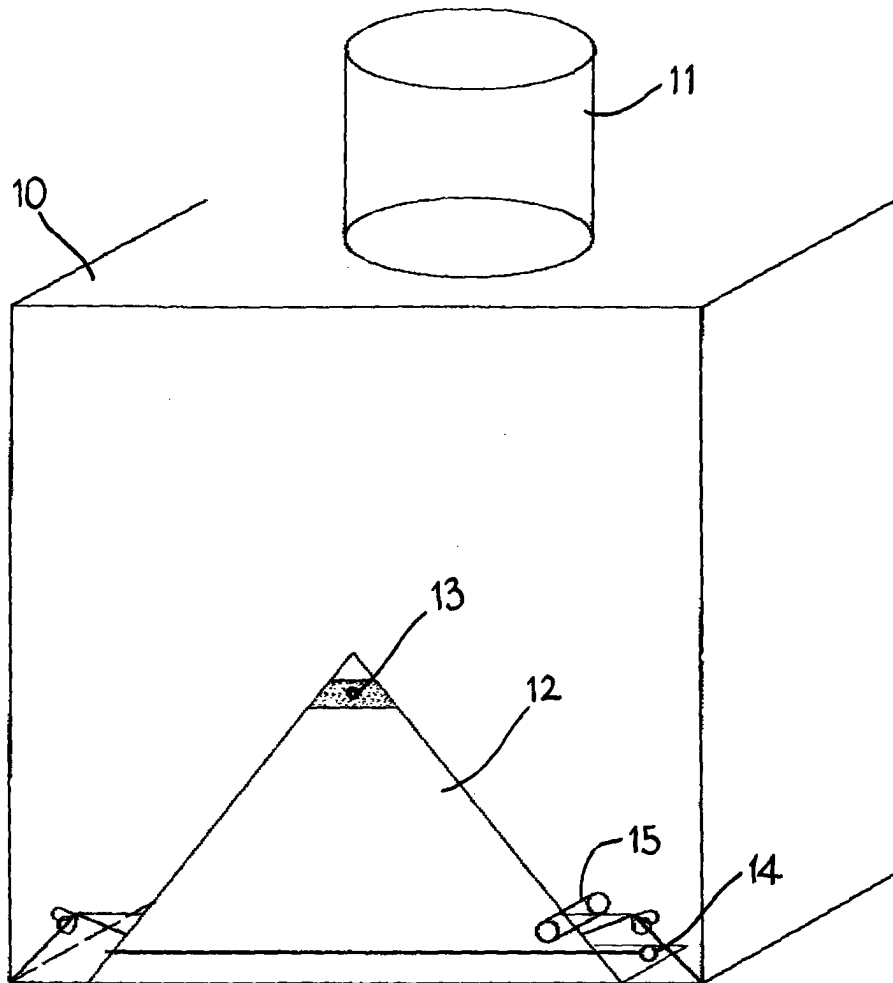

Fig. 1

FRONT END

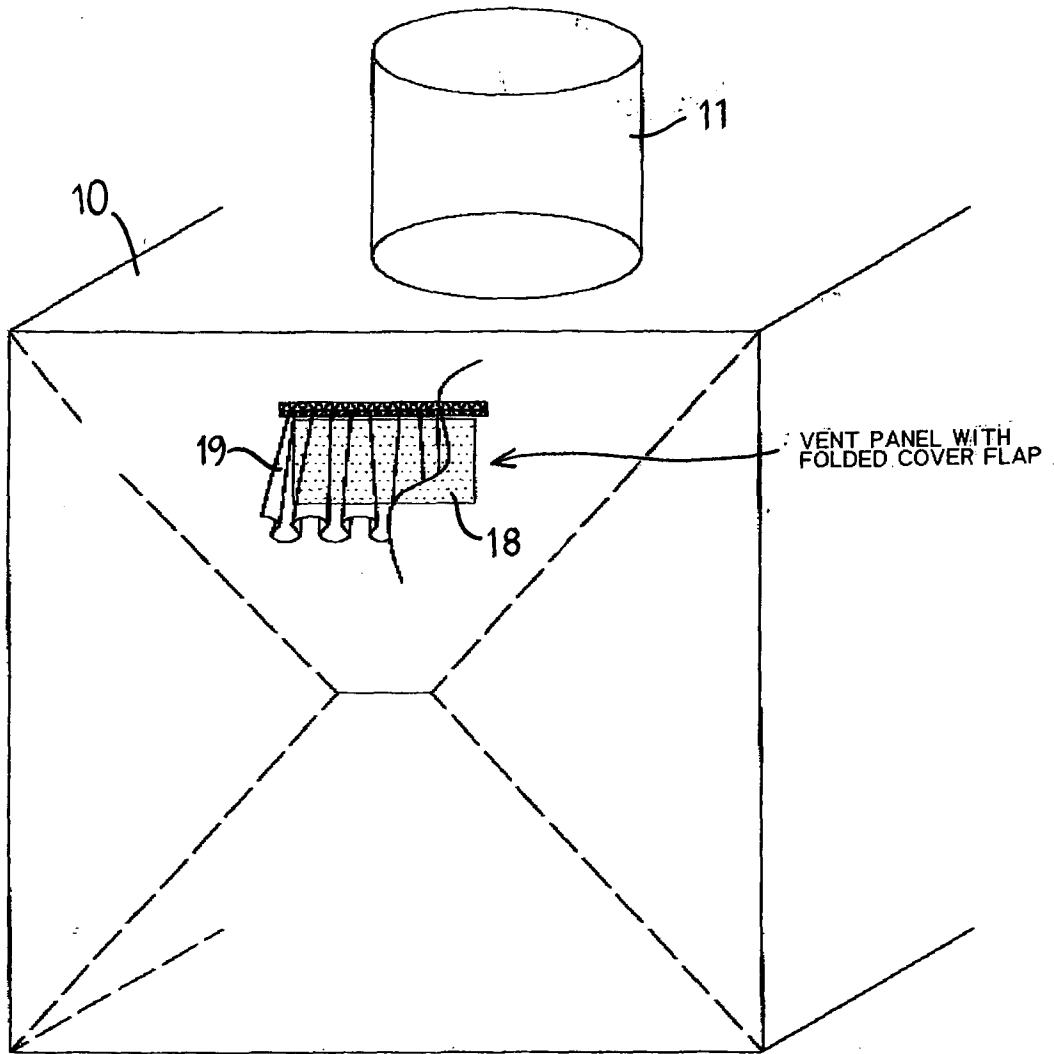

Fig. 2



DOCUMENTS CONSIDERED TO BE RELEVANT			
Category	Citation of document with indication, where appropriate, of relevant passages	Relevant to claim	CLASSIFICATION OF THE APPLICATION (Int.Cl.7)
X	DE 101 22 885 A (BASF AG) 14 November 2002 (2002-11-14) * paragraph '0008! *	1-8,10, 19-25,30	B65D90/04 B65D90/34
Y	* column 3, line 55 - line 57; figure 1 * ---	26,27	
Y	GB 2 375 096 A (GIBBONS GEORGE ALFRED JOSEPH) 6 November 2002 (2002-11-06) Page 4, legend of icons (ref.4, 7) * figure 1 *	26,27	
A	---	1,16	
X	US 5 421 476 A (MATIAS CARLOS J D) 6 June 1995 (1995-06-06) * column 4, line 5 - line 11 * * column 10, line 65 - column 11, line 7; figure 16 * * column 13, line 30 - line 36 *	1,30 26	
A	---		
X	FR 2 461 661 A (KLEBER COLOMBES) 6 February 1981 (1981-02-06) * page 2, line 11 - line 18; figure 2 *	1-3,26, 30	
A	---		
A	US 5 193 710 A (PODD SR VICTOR T ET AL) 16 March 1993 (1993-03-16) * column 5, paragraph 2 *	1,23,30	TECHNICAL FIELDS SEARCHED (Int.Cl.7) B65D
A	---		
A	GB 2 121 361 A (FELL LAWRENCE LTD;FELL DON LTD) 21 December 1983 (1983-12-21) * page 2, line 16 - line 18; figure 5 * -----	1,26,30	
The present search report has been drawn up for all claims			
Place of search THE HAGUE		Date of completion of the search 15 April 2004	Examiner Zanghi, A
CATEGORY OF CITED DOCUMENTS X : particularly relevant if taken alone Y : particularly relevant if combined with another document of the same category A : technological background O : non-written disclosure P : intermediate document		T : theory or principle underlying the invention E : earlier patent document, but published on, or after the filing date D : document cited in the application L : document cited for other reasons & : member of the same patent family, corresponding document	

EPO FORM 1503 03/82 (P04/C01)



<p>CLAIMS INCURRING FEES</p> <p>The present European patent application comprised at the time of filing more than ten claims.</p> <p><input type="checkbox"/> Only part of the claims have been paid within the prescribed time limit. The present European search report has been drawn up for the first ten claims and for those claims for which claims fees have been paid, namely claim(s):</p> <p><input type="checkbox"/> No claims fees have been paid within the prescribed time limit. The present European search report has been drawn up for the first ten claims.</p>
<p>LACK OF UNITY OF INVENTION</p> <p>The Search Division considers that the present European patent application does not comply with the requirements of unity of invention and relates to several inventions or groups of inventions, namely:</p> <p>see sheet B</p> <p><input type="checkbox"/> All further search fees have been paid within the fixed time limit. The present European search report has been drawn up for all claims.</p> <p><input checked="" type="checkbox"/> As all searchable claims could be searched without effort justifying an additional fee, the Search Division did not invite payment of any additional fee.</p> <p><input type="checkbox"/> Only part of the further search fees have been paid within the fixed time limit. The present European search report has been drawn up for those parts of the European patent application which relate to the inventions in respect of which search fees have been paid, namely claims:</p> <p><input type="checkbox"/> None of the further search fees have been paid within the fixed time limit. The present European search report has been drawn up for those parts of the European patent application which relate to the invention first mentioned in the claims, namely claims:</p>



The Search Division considers that the present European patent application does not comply with the requirements of unity of invention and relates to several inventions or groups of inventions, namely:

1. Claims: 1-25, 30

A liner for a bulk cargo container having a cargo discharge hatch, the liner comprising support means in the region corresponding to the discharge hatch to prevent bulging of the liner through the discharge hatch wherein the support means is movable from a first position in which it prevents bulging of the liner to a second position in which the liner is not supported.

2. Claims: 26-29

A liner for a bulk cargo container having a cargo discharge hatch, the liner comprising support means in the region corresponding to the discharge hatch to prevent bulging of the liner through the discharge hatch wherein the liner further comprises a self-venting port.

ANNEX TO THE EUROPEAN SEARCH REPORT
ON EUROPEAN PATENT APPLICATION NO.

EP 04 25 0201

This annex lists the patent family members relating to the patent documents cited in the above-mentioned European search report. The members are as contained in the European Patent Office EDP file on
The European Patent Office is in no way liable for these particulars which are merely given for the purpose of information.

15-04-2004

Patent document cited in search report		Publication date	Patent family member(s)	Publication date
DE 10122885	A	14-11-2002	DE 10122885 A1	14-11-2002
			WO 02092471 A1	21-11-2002
			EP 1387803 A1	11-02-2004
GB 2375096	A	06-11-2002	NONE	
US 5421476	A	06-06-1995	US 5222621 A	29-06-1993
			US 5137170 A	11-08-1992
			US 5542563 A	06-08-1996
			US 5657896 A	19-08-1997
			JP 6024486 A	01-02-1994
			AT 177401 T	15-03-1999
			BR 9202694 A	23-03-1993
			DE 69228579 D1	15-04-1999
			DE 69228579 T2	18-11-1999
			EP 0528533 A1	24-02-1993
FR 2461661	A	06-02-1981	FR 2461661 A1	06-02-1981
US 5193710	A	16-03-1993	AU 1356495 A	04-05-1995
			AU 655141 B2	01-12-1994
			AU 2581792 A	05-04-1993
			AU 719432 B2	11-05-2000
			AU 6063198 A	04-06-1998
			BR 9206496 A	14-03-1995
			CA 2114613 A1	18-03-1993
			DE 69215378 D1	02-01-1997
			DE 69215378 T2	13-03-1997
			EP 0603293 A1	29-06-1994
			JP 8509187 T	01-10-1996
			KR 239945 B1	02-03-2000
			KR 202445 B1	15-06-1999
			KR 202444 B1	15-06-1999
			WO 9304955 A2	18-03-1993
			US 5632400 A	27-05-1997
			US 5692546 A	02-12-1997
GB 2121361	A	21-12-1983	CA 1179613 A1	18-12-1984

EPO FORM P0459

For more details about this annex : see Official Journal of the European Patent Office, No. 12/82