

(No Model.)

3 Sheets—Sheet 1.

A. HUNTER. SCALPING AND GRADING DEVICE.

No. 420,723.

Patented Feb. 4, 1890.

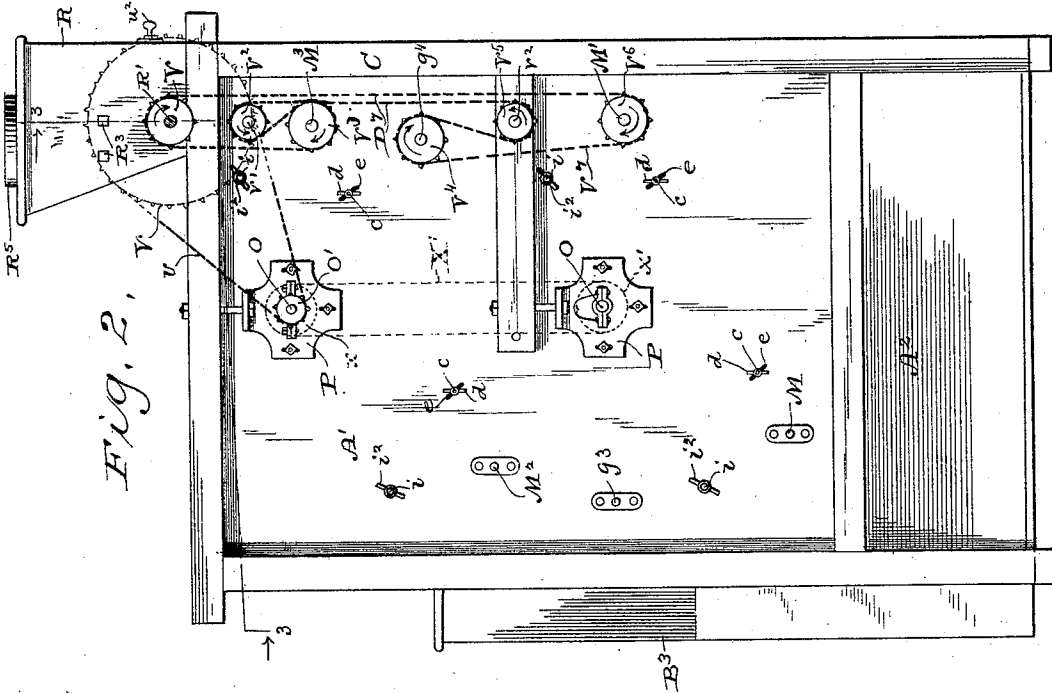

Fig. 2.

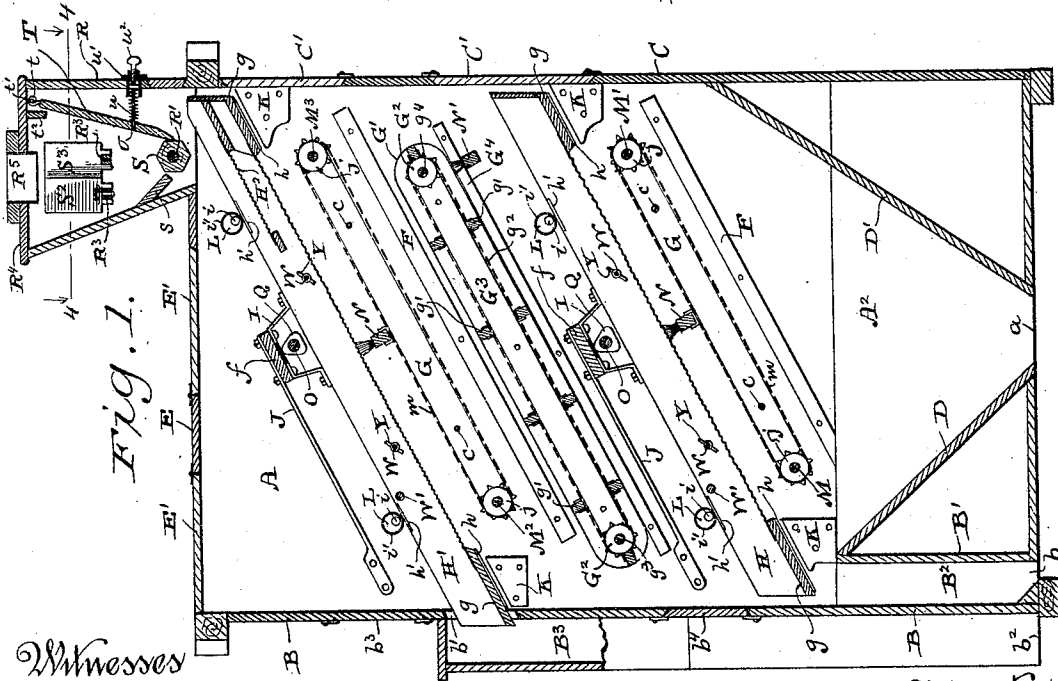

Fig. 1.

Witnesses
 Geo. W. Louny.
 N. E. Oliphant

Inventor
 Andrew Hunter
 By J. H. Underwood
 Attorneys

(No Model.)

3 Sheets—Sheet 2.

A. HUNTER.
SCALPING AND GRADING DEVICE.

No. 420,723.

Patented Feb. 4, 1890.

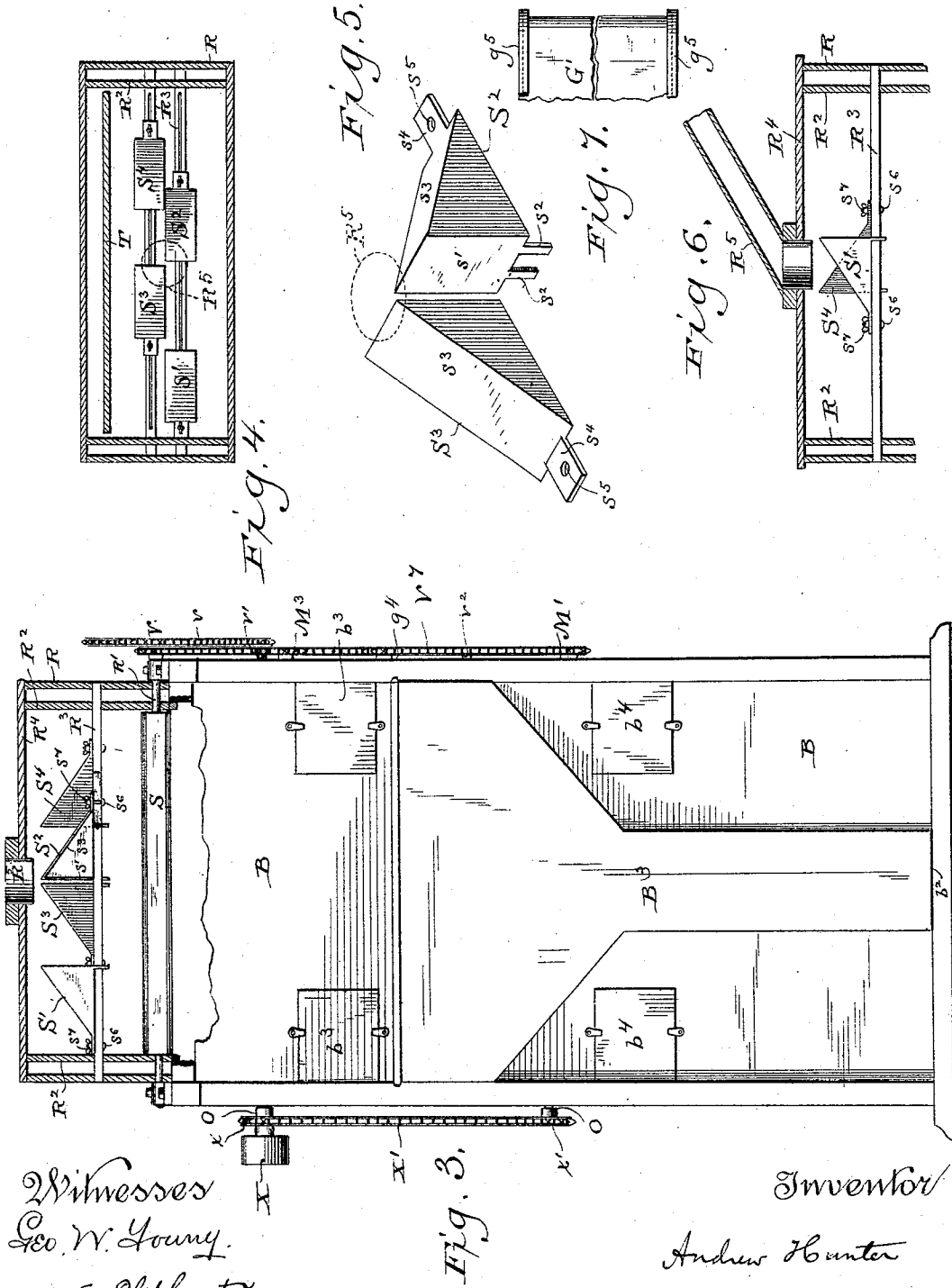

Witnesses
Geo. W. Young.
N. E. Slipant

Fig. 3.

Inventor
Andrew Hunter
By *Frank Underwood*
Attorneys

(No Model.)

3 Sheets—Sheet 3.

A. HUNTER.
SCALPING AND GRADING DEVICE.

No. 420,723.

Patented Feb. 4, 1890.

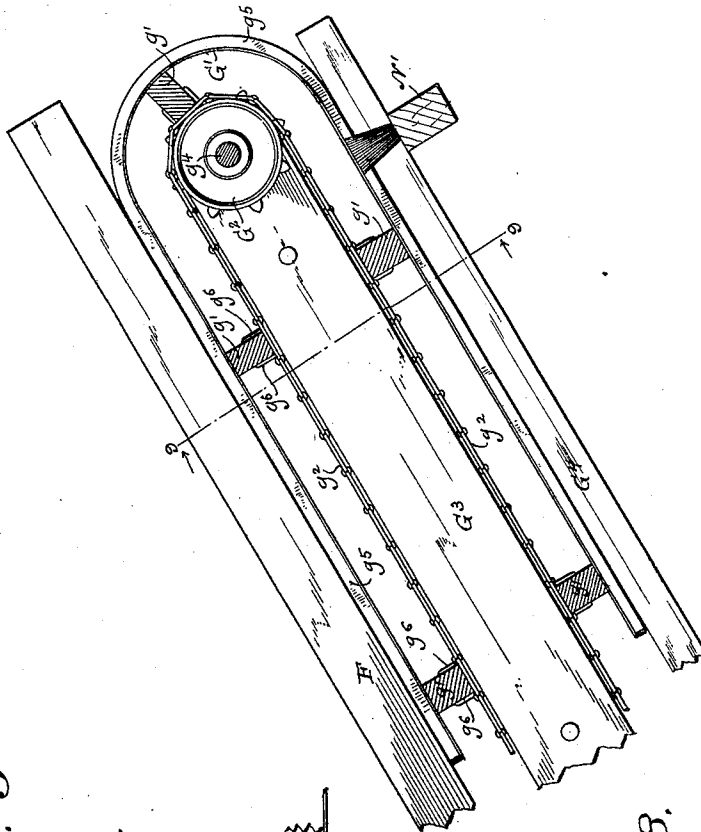

Fig. 9

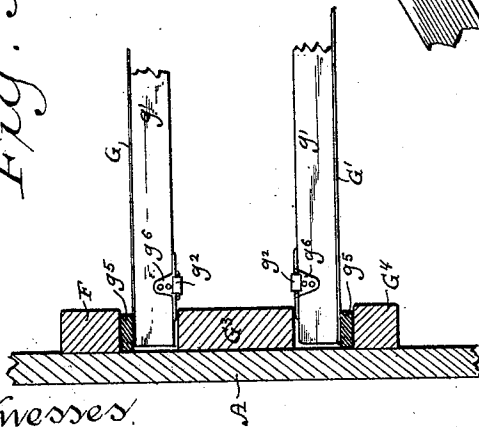

Fig. 8.

Witnesses
Geo. W. Young.
A. E. Diphant

Inventor
Andrew Hunter
By Stout & Underwood
Attorneys

UNITED STATES PATENT OFFICE.

ANDREW HUNTER, OF MILWAUKEE, WISCONSIN.

SCALPING AND GRADING DEVICE.

SPECIFICATION forming part of Letters Patent No. 420,723, dated February 4, 1890.

Application filed February 26, 1889, Serial No. 301,212. (No model.)

To all whom it may concern:

Be it known that I, ANDREW HUNTER, of Milwaukee, in the county of Milwaukee, and in the State of Wisconsin, have invented certain new and useful Improvements in Scalping and Grading Devices; and I do hereby declare that the following is a full, clear, and exact description thereof.

My invention relates to scalping and grading devices for the treatment of breaks and other products resulting from the manufacture of grain into flour, and will be fully set forth hereinafter, and pointed out in the claims.

In the drawings, Figure 1 is a vertical longitudinal section through my improved machine, taken near one side thereof. Fig. 2 is a side elevation. Fig. 3 is an elevation of the tail end of my machine, with the upper portion partially in section on the line 3 3 of Fig. 2. Fig. 4 is a sectional view of the feed-hopper on the line 4 4 of Fig. 1. Fig. 5 is a detail perspective view of the adjustable distributors in the hopper. Fig. 6 is a vertical longitudinal sectional view of the feed-hopper, but with two of the adjustable distributors in a different position from that shown in Fig. 3 and the others removed. Fig. 7 is a detail of the endless carrying-apron. Fig. 8 is an enlarged detail longitudinal sectional view; and Fig. 9 is an enlarged detail transverse sectional view on the line 9 9 of Fig. 8, illustrating the construction and operation of the endless carrying-apron.

My present invention is, in part, an improvement on that set forth in my application for patent filed January 9, 1889, Serial No. 295,868, and, like that machine, comprises side walls A A', tail end B, and head end C, a four-sided hopper in the lower part of the machine formed by the inclined cant-boards A², (projecting inwardly from the lower portions of the side walls A and A',) D, and D', with discharge-opening *a*, the cant-board D' extending up to the head-wall C, while the board D extends up only to the height of the partition B', which forms one wall of the spout B² between said partition and the tail-wall B, said spout having its discharge-opening at *b*, all as before described in said prior

application; but in this present device I show an additional spout B³ on the exterior of the tail-wall B, which spout communicates with the interior of the machine at *b'* and has its discharge-opening at *b²*, there being openings in the tail-wall B above said spout, closed by doors or slides *b²b³*, and lower down, as shown at *b⁴b⁴*, for affording a convenient means of access to the interior of the machine from the rear.

E represents the top of the machine having openings at convenient intervals closed by doors E'. The head-wall C has similar doors C'.

In my present machine I show a series of screens, which are each practically the same as the single screen shown in said former application, except in variation of mesh, as hereinafter described, and while I have here illustrated two of such screens (marked H and H') it will be understood that I may employ any suitable number, each screen having its separate discharge-spout at the tail end, and each two adjacent screens may be separated, if desired, by the endless apron or carrier shown and hereinafter described.

Each screen, as in my said prior application, has secured to the top of its side walls and at about the center thereof stirrups I, united by a transverse piece *f*, to each end of which is secured one end of a wooden or metallic spring-strip J, whose other ends are secured to the side walls of the machine, and the arrangement of cross-strips *g g* on the under side of the screens and the subadjacent brackets or rests K K is the same as before, save that I have here shown the leather, rubber, or other pieces *h h* as secured to the cross-strips *g g*, instead of said brackets K K. Above the screens I have shown the same eccentric stops L as before, having shanks *i*, which pass through and are (after adjustment) secured to the side walls A A' of the machine, as by thumb-nuts *i²*, and the said stops L may be covered with rubber or like material *i'*, as before, and are placed above and near each end of the screen-frames, which latter may have pieces of rubber or other suitable material on the top surface of the side walls, as at *h'*, as before, and like stops L

may be similarly placed above each of the spring-strips J, all as described in said prior application.

M M' and M² M³ are the rods extending through the machine, carrying the inside sprocket-wheels *j*, engaging with sprocket-chains *m*, which latter are united by the transverse brushes or scrapers N, whose ends travel around adjustable guides G and between the same and stationary guides F, (the adjustment of the guides G being provided by means of slots *e* in the side walls, bolts *c*, and thumb-nuts *d*.) the said brushes or scrapers operating against the lower surfaces of the screens H and H', as in said prior application, and, as before, the screens are agitated by cams Q on shafts O, journaled in vertically-adjustable boxes P.

Interposed between the upper screen H' and lower screen H, in Fig. 1, I show an endless carrying-apron G', secured to cross-strips *g' g'*, which latter are in turn secured to extension-links *g⁶* in sprocket-chains *g²*, which engage with sprocket-wheels G² on shafts *g³* *g⁴*, and the ends of these cross-strips *g' g'* travel around a guide G³, and between it and a subadjacent guide G⁴ (both stationary) and near the head end of this carrying-apron its under side is in contact with a transverse stationary brush N'. My upper screen H' differs from the lower screen only in the addition of a strip of coarser-meshed screen-cloth H², extending back from its head end a certain distance and being of the full width of the screen and located above the screen-bottom, so as to first receive the material from the feed-hopper R, allowing the fine particles to pass through its meshes and the coarser particles to fall from its rear edge upon the bottom of said upper screen H'. In some cases for the largest mills I may place another complete screen directly above the screen H', in place of adding the screen-cloth H² to said upper screen; but in ordinary cases I prefer the construction illustrated.

I have shown my present screens provided with cross-rods W and thumb-nuts Y, as in my prior application, to stretch the wire-cloth or other material of which the screen-bottoms are composed and prevent sagging, the sides of the screens being united by cross-rods W' and the transverse strips *f* above the plane of the cross-rods W.

The feed-hopper R, like that in my prior application hereinbefore named, is provided with a feed-roller S on a shaft R', cant-board *s*, pivoted feed-board T, hung by hooks *t* to loops or eyes *t'*, transverse guard-strip *l²*, and springs *u* on guide-pins U in cups *u'*, with adjusting-screws *u²*, and extending the entire width of the machine. The hopper is made with inner end pieces R² R², (to make the feed of the hopper within the width of the screen,) and extending from end to end of said hopper are two longitudinally-slotted bars R³ R³, located above the feed-roller S and cant-board *s* and about midway in height of the hop-

per, and supported on these bars R³ are the adjustable distributors S' S² S³ S⁴, each having an inner vertical face *s'*, terminating in downward projections *s²* *s²*, which straddle one of the bars R³, and an outwardly and downwardly inclined face *s³*, terminating in a horizontal flange *s⁴*, which rests on said bar R³, and has a perforation *s⁵* in line with the slot in said bar for the reception of a securing-bolt *s⁶*, passed through said slot and perforation and fastened by a thumb-nut *s⁷* when the distributor is in the desired position. These distributors may be of metal or wood and either solid or shells, but are preferably formed of iron plates, which may be simply bent into the required shape and need not have any other faces or sides than those just described.

My feed-hopper R has a closed top R⁴, perforated for the reception of the delivery-pipe R⁵, which conveys the breaks, middlings, or other material which is to be treated to said hopper.

In Figs. 2 and 3 I show the driving-connections as applied to a machine having two screens, such as is illustrated in Fig. 1. X is the driving-pulley, which receives power from the main belt, (not shown,) and this pulley is on one end of the upper cam-shaft O, which carries a sprocket wheel or pulley *x*, connected by chain or belt X' with another sprocket wheel or pulley *x'* on the end of the lower cam-shaft O, and thus drives the latter, while the other end of the upper shaft O carries a sprocket-wheel O', connected by sprocket-chain *v* to a larger sprocket-wheel V on the end of feed-roller shaft R', and just inside this larger wheel V is a small sprocket-wheel V' on the same shaft R', below which is a sprocket-idler V², mounted on a stud *v'* on the side wall A' of the machine, and below this a sprocket-wheel V³ on the end of the shaft M³, below this a sprocket-wheel V⁴ on the end of shaft *g⁴*, and next a sprocket-idler V⁵ on a stud *v²*, and finally a sprocket-wheel V⁶ on the end of shaft M', and these various sprocket wheels and idlers are all connected by a sprocket-chain V⁷, which engages them in this order: V', V⁶, V⁴, V⁵, V², V³, and back to V', as shown by the arrows in Fig. 2.

It will be understood that if I increase the number of screens I must add sprocket wheels and idlers for the shafts thereof and rearrange my driving chains or belts correspondingly.

The operation of my machine will be readily understood from the foregoing description of its construction. Suppose the delivery-pipe R⁵ is a straight pipe, set in either a perpendicular position or at an angle to such position, but in a line at right angles to the greatest length of the hopper. Then the adjustable distributors would be moved on their bars R³ until the vertical faces *s'* of each pair are in contact beneath the center of the discharge end of the spout R⁵, and secured in this position by the set bolts and nuts *s⁶* *s⁷* described. Then the material will be evenly divided, and

half will be deflected toward each end of the feed-roller below. By separating slightly each pair of distributors at the center the material will be divided, so that a part will go to the center of the feed-roller S, and the balance be divided, as before, and directed toward the ends thereof. If, again, we leave, say, distributors S³ and S² in this last position and move distributors S¹ and S⁴ out of the way, as shown in Figs. 3 and 4, about half of the material will fall directly on the center of the feed-roller, and the balance will be distributed between the center and ends of the feed-roller. Again, suppose the pipe R⁵ approaches the feed-hopper R in line with the greatest length of said hopper, as shown in Fig. 6. The material in running down precipitates the middlings to the bottom of this pipe, with the lighter particles on top of said middlings, and hence the hereinbefore-described positions of the distributors would not satisfactorily and evenly divide the contents of the pipe R⁵, but would, if the distributors were all together at the center, send the light particles toward one end of the feed-roller and the heavy particles toward the other end; or if the distributors were as shown in Figs. 3 and 4, then half of the lighter particles would be sent toward one end and half of the heavy particles toward the other end, and the balance of each be distributed between the center and ends, but still kept separate; hence to overcome this difficulty I would remove distributors S² and S³, (or push them back away from beneath the discharge-opening of the pipe R⁵), and adjust distributors S¹ and S⁴ to the relative positions shown in Fig. 6, and then the contents of the pipe would be evenly distributed and equal quantities of the combined heavy and light particles would be directed toward each end of the feed-roller. It will thus be seen that there is practically no limit to the changes which may be made in the adjustment of my distributors to compensate for the different angles or positions of the feed-delivery pipes in different machines.

The operation of my screens, cam-shafts, and traveling brushes is obvious and identical with that set forth in my hereinbefore-named prior application; but the interposed carrying-apron produces a new and better result in connection with a series of said screens; the upper screen being provided with cloth of a coarser mesh than the screen below, and this being the case with all the screens in the series, each one being of coarser mesh than the screen below and of finer mesh than the screen above.

The object of the carrying-apron G¹ is to receive the material that sifts through the meshes of the screen above it on the entire upper exposed portion of said apron and to carry the same continuously up to the head end of the machine, and by the revolution of

said apron to cause said material to drop off onto the upper or head end of the screen below, this action being, as stated, continuous, and, on account of the described chain connections, automatic. The apron is freed from adhesive particles at any suitable point on its under side by means of the stationary brush N¹.

To prevent the material from falling off the sides of the apron while being elevated thereby, and also to form a bearing-surface for said apron on the guides G⁴, I re-enforce the apron on its outer surface on each side, along the entire edge, with flexible strips g⁵ g⁵, preferably of leather, said strips being of sufficient thickness to serve to retain the material between them and to keep the apron from frictional contact with the described guides G⁴ on its downward travel; and, further, by reason of the contact of said strip g⁵ with the casing of the machine, they exclude air and prevent the deposit of light pulverized material within the space between the parallel faces of the said apron.

Having thus described my invention, what I claim as new, and desire to secure by Letters Patent, is—

1. The combination of a feed-hopper and a feed-roller located in the lower portion of said hopper with supporting-bars above said feed-roller and a series of distributors adjustably secured to said bars, substantially as set forth.

2. The combination of a feed-hopper having a closed top provided with an opening, a feed-delivery pipe communicating with said opening, a feed-roller located in the lower portion of said hopper, supporting-bars above said feed-roller, and a series of distributors secured to said bars and capable of adjustment thereon to vary their relative position with respect to the feed-pipe opening above, substantially as set forth.

3. The combination, with a feed-hopper and feed-roller, of a series of distributors adjustably supported above said feed-roller within said hopper, and each having a vertical inner face and a downward and outwardly inclined upper face, substantially as set forth.

4. In a scalping and grading device, the combination of a pair of inclined screens with an interposed endless carrying-apron, stationary guides for said apron, and flexible strips secured to the outer surface of said apron on each side along the entire edge, substantially as and for the purposes set forth.

In testimony that I claim the foregoing I have hereunto set my hand, at Milwaukee, in the county of Milwaukee and State of Wisconsin, in the presence of two witnesses.

ANDREW HUNTER.

Witnesses:

H. G. UNDERWOOD,
WILLIAM KLUG.