

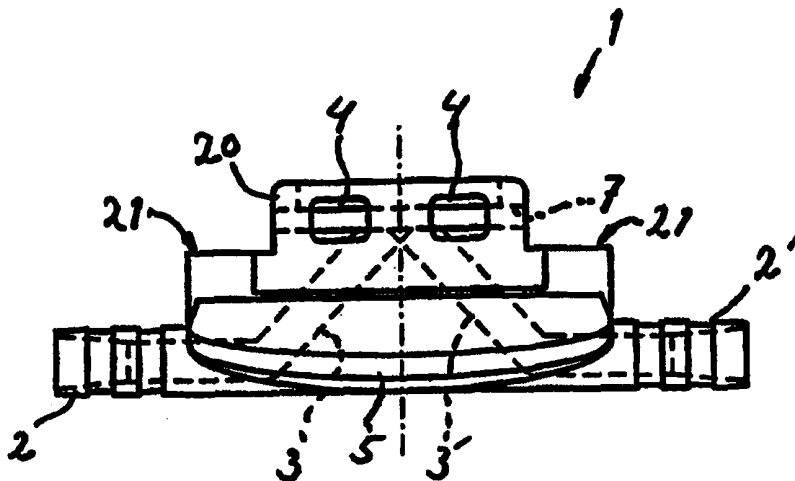

INTERNATIONAL APPLICATION PUBLISHED UNDER THE PATENT COOPERATION TREATY (PCT)

(51) International Patent Classification ⁶ : A61M 39/02, 39/00, 1/00	A1	(11) International Publication Number: WO 99/20338 (43) International Publication Date: 29 April 1999 (29.04.99)
<p>(21) International Application Number: PCT/SE98/01880</p> <p>(22) International Filing Date: 20 October 1998 (20.10.98)</p> <p>(30) Priority Data: 9703839-2 21 October 1997 (21.10.97) SE</p> <p>(71) Applicant (for all designated States except US): HEMAPURE AB [SE/SE]; P.O. Box 938, S-751 09 Uppsala (SE).</p> <p>(72) Inventors; and (75) Inventors/Applicants (for US only): DANIELSON, Bo, G. [SE/SE]; S Parkvägen 1, S-756 45 Uppsala (SE). PERS-SON, Dick [SE/SE]; PL 605, S-820 50 Los (SE).</p> <p>(74) Agents: MODIN, Jan et al.; Axel Ehner's Patentbyrå AB, P.O. Box 10316, S-100 55 Stockholm (SE).</p>	<p>(81) Designated States: AL, AM, AT, AT (Utility model), AU, AZ, BA, BB, BG, BR, BY, CA, CH, CN, CU, CZ, CZ (Utility model), DE, DE (Utility model), DK, DK (Utility model), EE, EE (Utility model), ES, FI, FI (Utility model), GB, GD, GE, GH, GM, HR, HU, ID, IL, IS, JP, KE, KG, KP, KR, KZ, LC, LK, LR, LS, LT, LU, LV, MD, MG, MK, MN, MW, MX, NO, NZ, PL, PT, RO, RU, SD, SE, SG, SI, SK, SK (Utility model), SL, TJ, TM, TR, TT, UA, UG, US, UZ, VN, YU, ZW, ARIPO patent (GH, GM, KE, LS, MW, SD, SZ, UG, ZW), Eurasian patent (AM, AZ, BY, KG, KZ, MD, RU, TJ, TM), European patent (AT, BE, CH, CY, DE, DK, ES, FI, FR, GB, GR, IE, IT, LU, MC, NL, PT, SE), OAPI patent (BF, BJ, CF, CG, CI, CM, GA, GN, GW, ML, MR, NE, SN, TD, TG).</p> <p>Published With international search report. In English translation (filed in Swedish).</p>	

(54) Title: CONNECTING DEVICE FOR MEDICAL PURPOSES



(57) Abstract

Device for external connection of the bloodstream of a patient to an external circuit or a fluidum source for medical purposes, comprising: a main body (1) with at least a first opening (8, 8') being surrounded by (a) first sealing surface (-s) (9, 9') and being adapted to be protected by a removable protective member (24), and a connecting member (10) with at least one second opening (12, 12') being arranged to be protected by a protective body (27) which is removable with respect to the connecting member, wherein the connecting member (10) is connectable to the main body (1) under simultaneous removal of the protective member (24) and the protective body in order to obtain leakproof connection between said openings, wherein the main body (1) is provided with holding elements (6) forming a guide (7) which is open in both ends for the protective member and the connecting member respectively. The invention also concerns a connecting unit for the connecting device.

FOR THE PURPOSES OF INFORMATION ONLY

Codes used to identify States party to the PCT on the front pages of pamphlets publishing international applications under the PCT.

AL	Albania	ES	Spain	LS	Lesotho	SI	Slovenia
AM	Armenia	FI	Finland	LT	Lithuania	SK	Slovakia
AT	Austria	FR	France	LU	Luxembourg	SN	Senegal
AU	Australia	GA	Gabon	LV	Latvia	SZ	Swaziland
AZ	Azerbaijan	GB	United Kingdom	MC	Monaco	TD	Chad
BA	Bosnia and Herzegovina	GE	Georgia	MD	Republic of Moldova	TG	Togo
BB	Barbados	GH	Ghana	MG	Madagascar	TJ	Tajikistan
BE	Belgium	GN	Guinea	MK	The former Yugoslav Republic of Macedonia	TM	Turkmenistan
BF	Burkina Faso	GR	Greece	ML	Mali	TR	Turkey
BG	Bulgaria	HU	Hungary	MN	Mongolia	TT	Trinidad and Tobago
BJ	Benin	IE	Ireland	MR	Mauritania	UA	Ukraine
BR	Brazil	IL	Israel	MW	Malawi	UG	Uganda
BY	Belarus	IS	Iceland	MX	Mexico	US	United States of America
CA	Canada	IT	Italy	NE	Niger	UZ	Uzbekistan
CF	Central African Republic	JP	Japan	NL	Netherlands	VN	Viet Nam
CG	Congo	KE	Kenya	NO	Norway	YU	Yugoslavia
CH	Switzerland	KG	Kyrgyzstan	NZ	New Zealand	ZW	Zimbabwe
CI	Côte d'Ivoire	KP	Democratic People's Republic of Korea	PL	Poland		
CM	Cameroon	KR	Republic of Korea	PT	Portugal		
CN	China	KZ	Kazakstan	RO	Romania		
CU	Cuba	LC	Saint Lucia	RU	Russian Federation		
CZ	Czech Republic	LI	Liechtenstein	SD	Sudan		
DE	Germany	LK	Sri Lanka	SE	Sweden		
DK	Denmark	LR	Liberia	SG	Singapore		
EE	Estonia						

CONNECTING DEVICE FOR MEDICAL PURPOSES

This invention concerns a device according the preamble of claim 1. It also concerns a connecting unit and a protective unit for use in such a device.

WO 92/13590 (corresponds to SE-B-467 769) concerns such a device, wherein a housing is provided with inward sealing surfaces surrounding connecting openings which are adapted to co-operate with outward sealing surfaces surrounding conduit openings on a coupling member which communicates with an external circuit. The sealing surfaces of the housing as well as of the connecting member are covered and protected by protective members in a non-connected position which in the process of connecting are adapted to be removed from and thereby uncover the respective sealing surfaces for achieving a leakproof connection.

The purpose of protecting the sealing surfaces is to avoid contamination of these as well as of the channels and thereby avoid or at least radically reduce the infection risks encountered by a patient using the connecting device.

The device being known from the cited document is functioning well but is relatively complex, which has resulted in likewise complicated and thereby relatively expensive production.

It is an aim of this invention to set the said problems aside and to provide a development of the known device which with retained high hygienic standard is uncomplicated to produce, simple to handle and possible to produce at a reduced cost.

These aims are achieved in a device as above by the feature of the characterising portion of claim 1.

By the holding elements forming a guide which is open at both ends for parts to be connected (the protective member and the connecting member respectively) it is achieved that the

5 connecting procedure may be accomplished by displacements of the part intended to be connected along said guide in one single displacement movement, whereby with this simple movement, as an example in case of connecting the connecting member, at the same time the protective member is removed from

10 the main body and thereby its active position. The displacement of the connecting member to the connecting position thus results in that co-operation is obtained between the respective sealing surfaces at the same time as the protective body is brought from the position where it protects the second sealing

15 surface (surfaces). It should be noted that a relative movement between the parts is intended and that in practice the protective body may be fix while the other parts are subject to a movement. When disconnecting the connecting member after completed treatment, the invention provides a corresponding

20 simultaneous placement of the protective member.

The connecting member thus does not have to be brought down into a housing in order to obtain the connecting position, which otherwise is the case with the prior art, where the

25 housing is provided with inward sealing surfaces. This results in considerable simplified manufacture compared to the known device, since the respective sealing surfaces are located on a surface which extends along the guide, resulting in essentially simplified production. A further advantage is that the hygienic

30 standard is further improved, since, according to the invention, no protective lid or the like has to be removed from the main body before the connecting procedure, which thus eliminates the need of exposing the inside of the housing

before it is possible to connect the connecting member. Instead connection may be made with a totally "closed" main body.

The main body hereby has no movable parts, which results in simplified and more economic manufacture and further better security and higher hygienic standard, in particular when it is applied as an implant (claims 5-8 etc.).

Claim 2 states a preferred embodiment of the guide, but also the construction according to claim 3 is adaptable and advantageous in certain cases.

By the sealing surfaces being plane, manufacture is simplified and the resulting product more economic.

The feature according to claim 5 concerns the use of the device according to the invention as a so called blood vessel valve which is useful for medical purposes where access to the blood stream is desirable, for example when taking samples from the blood stream, administration of different medicals, nutrition, cell treatment, determining of levels of substances in the blood stream etc. The means for supporting growth may be flange-like, longitudinally oriented elements or the like. An implanted main body will have the skin level somewhat above these means and with the upper part with the guide etc. above the skin level and being accessible for connecting the respective element. The construction according to the invention with open guide configuration in this connection results in simplified handling for the patient and/or the medical personnel.

30

In use of the blood vessel valve for CRRT (Cronic Renal Replacement Therapy), blood treatment/dialyses and in a number of different applications i.e. connecting other types of artificial organs than artificial kidneys, in gas exchange such

as oxidisation etc. there are two coupling means and two first and two second openings in the device according to the invention (claim 6). The construction of the main body hereby allows effective drawing of channels such as to effectively
5 reduce the flow resistance in the device as a whole. All taken together, the device according to the invention is particularly preferred as a blood vessel valve.

The feature according to claim 7 allows simply producible and
10 easy to handle means for mutual holding.

The feature according to claim 8 results in that the coupling means are connected to each other in a simple way when the protective member is placed in its active position which in
15 case of an implant assures that all the time there is a flow through the device, thus eliminating the formation of coagulated blood.

An aspect of the invention which considerably simplifies
20 handling the device is defined in claim 9 and particularly in claim 10. To this end the protective body thus comprises a guiding means for simplified application, and when lockable and openable fastening means are present for co-operation with the main body, the user thus only needs to activate these means in
25 order to obtain adequate guidance of the connecting member (or any other part), which means that the device will be essentially more simple to handle for the patient himself or the medical personnel in case of an implanted main body.

30 The feature according to claim 11 allows direct access to the blood stream through a membrane which is penetratable with an injection needle.

The feature according to claim 12 results in advantageous sealing functions.

5 The invention also concerns a connecting unit and a protective unit respectively for the use with a device in accordance with any of claims 1-12.

The invention will now be described in more detail at the background of embodiments and with reference to the annexed
10 drawings wherein:

Fig. 1a - 1c shows a main body in a side view, and end view and a plane view from above respectively,

15 Fig. 2a - 2c shows a connecting member in a plane view from above, a longitudinal section and an end view as seen in the direction against the insertion direction respectively,

20 Fig 3a - 3b shows a protective member in a plane view from above and a longitudinal section respectively,

Fig 4 shows a main body and a protective body with applied connecting member before an imagined connecting process with the protective body having an open holding means,
25

Fig 5 shows the protective body having a closed holding means,

30 Fig. 6a - 6c shows a modified main body in a side view, and end view and a plane view from above respectively,

Fig. 7a - 7b shows a modified connecting member in a plane view from above and in an longitudinal section,

Fig. 8a - 8c shows a membrane unit in a plane view from above, from below and in a transverse section respectively,

Fig. 9 shows the modified main body of Fig. 6 and a modified protective body having applied connecting member before an imagined connecting process, and

Fig. 10a and 10b shows the protective body of Fig. 9 with the slide in the different displacement positions.

10

In Fig. 1a 1 indicates a main body having oppositely directed outgoing coupling means 2 and 2', which over channels 3 and 3' respectively are connected to first openings 8 and 8' respectively which are placed in a plane extending in parallel with the longitudinal direction of the main body, which is more evident on Fig. 1b and 1c. In the areas around the first openings 8, 8' portions of said plane comprises first sealing surfaces 9 and 9' respectively. In Fig. 1b further are shown holding elements 6 on the main body 1 which are L-shaped, longitudinal, inwardly directed rims which together with the plane providing the sealing surfaces 9, 9' forms a linear guide 7 (Fig. 1b) for co-operation with elements being intended to be connected to the main body. 4 indicates coupling openings allowing access to the guide 7 from the side in a way that will be further explained below. When the main body according to the invention is intended to be implanted, it is preferred that means 5 for supporting growth of human tissue are arranged which means in this case are outwardly directed flange-like wings with possible holes penetrating the material. C.f. Fig. 6c, wherein in growth holes/sewing holes 45' are made in the flange-like means 45.

25

30

From Fig. 1a it is further clear that the main body is made with an overstructure 20 for connecting purposes with respect

to a basic plane 21, which in turn is located below the plane including the first sealing surfaces 9, 9'.

Fig. 2a shows a connecting member 10, which comprises conduits 5 11, 11' (indicated with interrupted lines) for the connection with an external circuit over a nipple portion 13 for the connection of tubing or the like. The connecting member 10 is further provided with holding means 17 formed as sideways directed linear flanges which are intended to co-operate with 10 the holding elements 6 of the main body (see particularly Fig. 1b). Further 14 indicates sideways directed snap wings for locking co-operation with the openings 4 in the main body (see Fig. 1a). 18 indicates locking shoulders which prevent a connecting member 10 from being brought through the guide 7 of 15 the main body, and these shoulders are intended to co-operate with shoulder recesses 19 in the main body (see Fig. 1c) for adequate positioning of the connecting member on the main body. The corresponding is also true for other parts intended to be connected to the main body, for example the protective member 20 (see Fig. 3a-b).

The holding means 17 provides in this case essentially centrally located pressing portions 15 which are comprised of somewhat vaulted resilient portions of the strips 17, said 25 pressing portions 15 being separated sideways from the main part of the connecting member 10 through slots 16. In use these portions 15 will guarantee safe pressing of the sealing surfaces against each other while allowing adequate absorption of possible play at the holding elements of the main body.

30

From Fig. 2b the drawing of one of the conduits 11 inside the connecting member, from the second opening 12 with surrounding second sealing surfaces to the nipple portion 13, is more clearly shown.

From Fig. 2c the construction of the holding means 17 is shown in more detail and being designed as strip-like guide flanges, and the locking shoulders 18 which through their co-operation with the recesses 19 assure fastening and correspondence with respect to the arrangement of openings. Interrupted lines indicate the second openings 12, 12', and 22, 22' indicate the respective second sealing surfaces.

Fig. 3a shows a protective member 24 with means 14, 15, 17 corresponding to the connecting member. It is further shown that the protective member is essentially plate-like having a transverse oblong recess 25, which in the applied position comprises connection channel between the openings 8, 8' in the main body in order to guarantee a continuous flow through the main body. 26 indicates the sealing surface surrounding the recess 25 (best shown in Fig. 3b) and which is co-operating with corresponding sealing surfaces on the main body.

Fig. 4 shows a protective body 27, which also function as a guiding body in respect of the connecting/disconnecting procedures, whereby 28 indicates a linear guide which corresponds to and is intended to coincide with the guide 7 of a main body 1 being inserted into a recess 29 which is adapted for that purpose and which thus is intended to receive the main body 1 surrounding its upper structure 20 (see Fig. 1a), whereby the material thickness of the protective body in the area of the guide is adapted to correspond to the distance between the base plane 21 of the main body 1 and the surface including the sealing surfaces 9, 9'. The protective body - guiding body 27 also includes a fastening arm 31, which is pivoted onto the main part of the body at 32 and which is provided with a snap lock means 33 for co-operation with a snap protrusion 34 at the upper part of the main part. Sideways

directed projections 30 are adapted, in the inserted position of the main body 1 and the upwards pivoted position of the fastening arm 31, to penetrate the openings 4 in the main body 1 and thereby on the one hand safely grip the main body, on the other hand press the snap wings 14 belonging to a protective member 24 being applied on the main body inwardly in such a way that they will disengage from the respective opening 4. Hereby protective member 24 is thus made free from the main body 1 and may be removed. This is accomplished by the connecting member 10, which is placed in the guide 28 of the protective body 27 being brought in the direction upwards as seen in the figure, whereby thus, at the same time the protective member 24 will come out from the main body 1 and be brought upwardly into the upper part of the guide 28. A continued insertion of the connecting member will result in the shoulders 18 abutting the shoulder recesses 19 while simultaneously the snap wings 14 will come in level with the openings which are most at the bottom of the figure. Final snapping-in will be obtained at the opening of the arm 31, when the projections 30 are removed from the openings 4 whereby safe and adequate locking of the connecting member 10 into the main body 1 is guaranteed. The protective body may now be removed from the main body by the arm 31 being pivoted downwardly and the protective body being brought sideways away from the main body. Through the invention is thus obtained very simple and fast switching from - as an example in case of an implanted blood vessel valve having two couplings - a position with active by-pass function through the channel of the protective member to a position with connected connecting member. In order to assure gathering of the connecting member and the protective member in the displacement direction, and thereby avoid separation in a longitudinal direction of these parts in connection with switching and at the same time simplify the displacement process, a displacement slide is preferably arranged so as to be adapted displaceably

on the guide of the protective body and comprising on the one hand means for controlling the position of the elements in the displacement direction, on the other hand for common displacement effect in the form of a "thumb grip" or the like.
5 This arrangement guarantees limited strain to the integration of the skin with the main body.

In order to connect an external circuit, a patient having an implanted main body thus needs a connecting unit including a
10 connecting member applied on and being protected by a protective body for the connecting procedure, and after completed treatment he will need a protective unit consisting of a new protective member applied to and being protected by a new protective body. Both these units are advantageously single
15 use articles.

From Fig. 5 the design of the protective body is shown - the guiding body 27 having upwardly pivoted and snapped-on fastening arm 31. Freeing of the coupling member and by the way
20 of the membrane member from the main body is accomplished in correspondence with what has been said above with respect to the protective member. When a member, coupling member, protective member or membrane member, is to be applied on the main body, the movement of insertion is opposite to the
25 movement of the member to be replaced in the shown embodiment. It is however not excluded that the same movement of insertion be used. In that case the holding arrangement onto the main body is modified.

30 On the modified main body 41 in Fig. 6a - c the outward coupling means 42 and 42' are directed somewhat obliquely downwards in order to enhance the flow through channels and facilitate placement at implantation. In this case there are only two diagonally located coupling openings 44 in order to

assure safety against wrongful connection. 44' concerns a guide opening shaped as an outwardly open one-way hole for co-operation with a sideways directed holder projection in the corresponding protective body/guiding body. 59 concerns in this case only two diagonally located shoulder recesses. Also these arrangements have the purpose of assuring adequate connection of the different details.

The somewhat modified connecting member 50 in Fig. 7a and b is provided with differently located nipple portions 53, which in this case with their channels 51 are comprised of generally straight continuations of channels 43 and 43' in the main body (see Fig. 6a) which gives reduced flow resistance in the device and thereby enhanced performance and also reduced tendency of forming thrombus. Further, in the connecting member, there is only one locking shoulder 58 and the snap wings 54 and the pressing portions 55 are located diagonally. Altogether this results in eliminating wrongful placement of the coupling member onto the main body.

A further advantage with channel disposition according to the invention is that it allows access to the channels in the main body and to the bloodstream for "thrombectomy", i.e. removing of coagulated blood or the like without surgery.

The invention may be modified within the scope of the following claims and is not limited to the shown embodiments. The invention may thus be used in a device with only one coupling and then as an implant as well as a hose coupling for use outside the human body.

Also other and differently shaped components may be arranged to be connected to the main body, for example a membrane unit which may have a construction essentially as the protective

member 24 but having a penetrable membrane limiting the channel
25 from the surroundings. The membrane may in a per se known
manner be penetrated with a needle in order to allow blood
sampling or introduction of medicals etc. into the blood
5 stream.

The membrane unit 80 in Fig. 8a - c thus includes a main part
80' having a body 80' with a through hole into which a
penetrable membrane 81 is inserted sealingly. As the case
10 with the protective member in Fig. 3a - b having the recess 25,
here a connection channel 81 is provided which in this case is
formed of the material of the membrane, whereby a sealing
surface 82 is arranged surrounding the channel 81. This
arrangement results in that safe sealing effect may be obtained
15 between this surface 82 and the corresponding surface of the
main body, eliminating the need of surface treatment of the
surfaces. A membrane unit of this kind may also be allowed to
remain, at least during certain periods, on an implanted main
body and thus replace particular protective members (Fig. 3a -
20 b) so that there will be no need of switching between such
parts before and after for example blood sampling or drug
administration.

As an alternative separate membrane units may be connected to a
25 connecting member over a hose (hoses).

Fig. 9 shows an assembly of the modified parts showing the
protective body 57 with a displacement slide 84 mounted on a
main body 41 and protective member and connecting member 50. 94
30 indicates a recess in the protective body forming a channel for
connection between the conduits 51 of the connecting member.
This construction allows prefilling of the channels in question
with a liquid such as a salt solution before application of the
connecting member in order to avoid introduction of air into

the bloodstream resulting in further increased safety against thrombus.

Fig. 10 a shows diagrammatically a protective body 57 with the
5 displacement slide 84 in an initial position, for example with
applied connecting member (not shown) to be applied to a main
body. The cover portion 85 is covering and prevents
manipulation with stopping and locking elements, namely a
locking tongue 86 which is placed in a first locking recess 87
10 in the protective body and first 89 and second 90 pawls,
whereof the first in this position co-operates with a first
catch recess 91. When connecting for example a connecting
member, the hand grip 93 is brought to the right in the figure,
whereby the first pawl is freed from its catch recess 91,
15 whereafter the entire slide may be brought to the right. In the
right position, in Fig. 10b, the locking tongue 86 co-operates
with a second locking recess 88, which is designed as a lock
catch for preventing movement to the left in the figure, and
the second pawl 90 co-operates with the second catch recess 92.
20 This way the protective body may not be reused unauthorised
whereby risks of infections by using potentially infected
material is avoided. Protective bodies constructed
correspondingly may be used for applying all the additional
parts.

25

The construction of details may deviate from shown embodiments.
The guide may thus be arranged differently, for example with
means corresponding to the holder elements 6 instead of being
placed on connecting member and vice versa. The guide may be
30 curved, for example circular, and the sealing surfaces may be
provided on a curved surface as seen perpendicular to the
connection direction. The drawing of channels may be arranged
differently with for example channels drawn in the same
direction in stead of in opposite directions.

The placement of and provision of snap means such as snap wings, locking shoulders etc. may deviate from what is shown. Also the elements for freeing a snap-locked connecting member or protective member may be varied with respect to construction and location.

The device may be used as an implant or as a separate coupling device having one or two outgoing couplings as well as openings and conduits in the respective portion. The invention provides several advantages whereof here only will be mentioned that the construction provides a safe, painless and convenient access to the bloodstream, so that it may be advantageously used by the patient in the home instead of by trained personnel at a hospital. This is also the result of using the spontaneous flow as the propellant, i.e. the use of the heart as a pump for propelling the blood through the blood treatment equipment or the like is possible and facilitated by an equipment according to the invention.

Materials which may be used are biocompatible if it is needed for the application in question. The construction according to the invention makes manufacture in synthetic materials well adapted, possibly having surfaces treating with blood or/and biocompatible coatings for all the parts in question. The parts may then be comprised of single use articles which are possible to produce at a low cost. Also manufacture in other material such as titanium or titanium alloys, possible having surfaces provided with blood and/or biocompatible layers for the implantable main body, may come into question,

Patent Claims

1. Device for external connection of the bloodstream of a patient to an external circuit or a fluidum source for medical purposes, comprising:

5 a main body (1;41) with at least a first opening (8,8') being surrounded by a first sealing surface (9,9') and communicating with an outward coupling means (2,2';42,42') which is connectable to the bloodstream, wherein in a non-connected position, the first sealing surface (surfaces) (9,9') is (are) adapted to be protected by a removable protective member (24), and

10 a connecting member (10;50) with at least one second opening (12,12') being surrounded by a second sealing surface (22,22') and for communicating with said circuit or source, which in a non-connected position is arranged to be protected by a protective body (27,57) which is removable with respect to the connecting member,

20 wherein the connecting member (10;50) is connectable to the main body (1;41) under simultaneous removal of the protective member 24 from the first sealing surface (surfaces) and the protective body from the second sealing surface (surfaces) in order to obtain co-operation between these surfaces and mainly leakproof connection between said openings, **characterised** in that the main body (1;41) is provided with holding elements (6) for the co-operation with holding means (17) on the protective body and the connecting member respectively, said holding elements forming a guide (7) which is open in both ends for the protective member and the connecting member respectively.

30

2. Device according to claim 1, **characterised** in that the guide 7 is linear.

3. Device according to claim 1, **characterised** in that the guide 7 is curved.
4. Device according to any of claims 1-3, **characterised** in
5 that the sealing surfaces (9,9';22,22';26) are plane.
5. Device according to any of the claims 1-4, **characterised** in
that the main body (1;41) is implantable and is provided with
flange-like means (5;45,45') preferably having several through
10 holes, for supporting growth of human tissue.
6. Device according to any of the claims 1-5, **characterised**
in that there are two coupling means (2,2';42,42') and two
first and two second openings.
15
7. Device according to any of the claims 1-6, **characterised** in
that either one of the main body (1;41) on the one hand and the
connecting member (10;50) and/or the protective member (24) on
the other hand is provided with snap lock means (14;54) for
20 mutual fastening in the respective applied position.
8. Device according to claim 6, or 7 when it depends on claim
6, **characterised** in that the protective member is provided with
a channel (25) for interconnecting the two first openings
25 (8,8') in the applied position.
9. Device according to any of claims 1-8, **characterised** in
that the protective body (27;57) is provided with means for co-
operation with the main body (1;41) so that the connecting
30 member before application thereon is directed into said guide
(7).

10. Device according to claim 9, **characterised** in that said means are comprised of lockable and openable fastening means (30,31)

5 11. Device according to any of the claims 1-10, **characterised** in a conduit member (80) including a penetratable membrane (81), which allows access to the opening (openings) of the main body, whereby preferably a resilient sealing surface (82) is arranged.

10

12. Device according to any of the claims 1-11, **characterised** in that the holding means (17) provides integral resilient pressing portions (15;55).

15

13. Connecting unit for use with a device according to any of the claims 1-12, **characterised** in that it includes a connecting member (10;50) with at least one (second) opening (12) being surrounded by a (second) sealing surface, for communicating with an external circuit or a fluidum source, and in a non-
20 connected position being arranged to be protected by a protective body (27;57) which is removable in respect of the connecting member, whereby the connecting member is provided with holding means (17) which are adapted to co-operate with holding elements (6) on a main body, which form a guide (7)
25 which is open at both ends, and whereby the protective body carries means for co-operation with the main body such that the connecting member before application thereto is arranged to be directed onto said guide.

30

14. Device according to claim 13, **characterised** in that said means are comprised of lockable and openable fastening means respectively (30).

15. Device according to claim 13 or 14, **characterised** in that the protective body is provided with a displacement slide (84), which together with the protective body (57) comprises locking means (86;92) for preventing its replacements after completed
5 connecting displacement.

16. Protective unit for use with a device according to any of the claims 1-12, **characterised** in that it includes a protective member (24) with protective surfaces (26) and a protective body
10 (27;57) which is removable in respect of the protective member, whereby the protective member is provided with holding means (17) which are adapted to co-operate with holding elements (6) on a main body, which form a guide (7) which is open at both ends, and whereby the protective body carries means for co-
15 operation with the main body such that the protective member before application thereto is arranged to be directed onto said guide.

17. Device according to claim 16, **characterised** in that said
20 means are comprised of lockable and openable fastening means respectively (30).

18. Device according to claim 16 or 17, **characterised** in that the protective body is provided with a displacement slide (84),
25 which together with the protective body (57) comprises locking means (86;92) for preventing its replacements after completed connecting displacement.

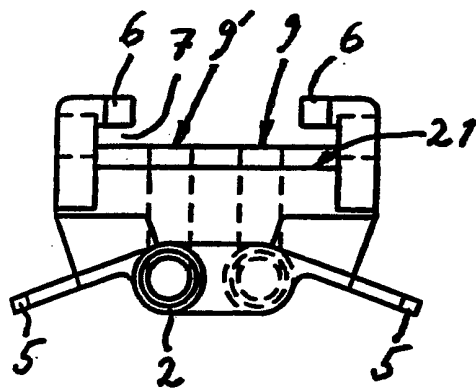
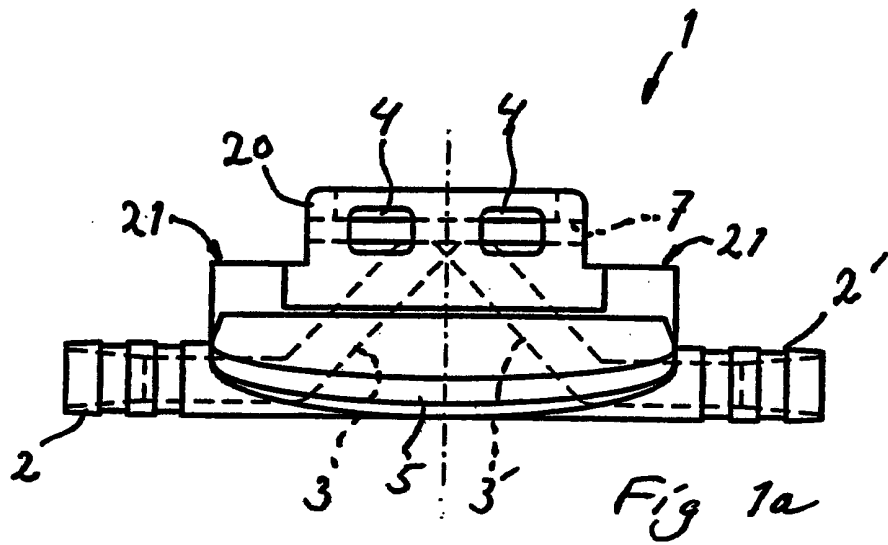

Fig 1b

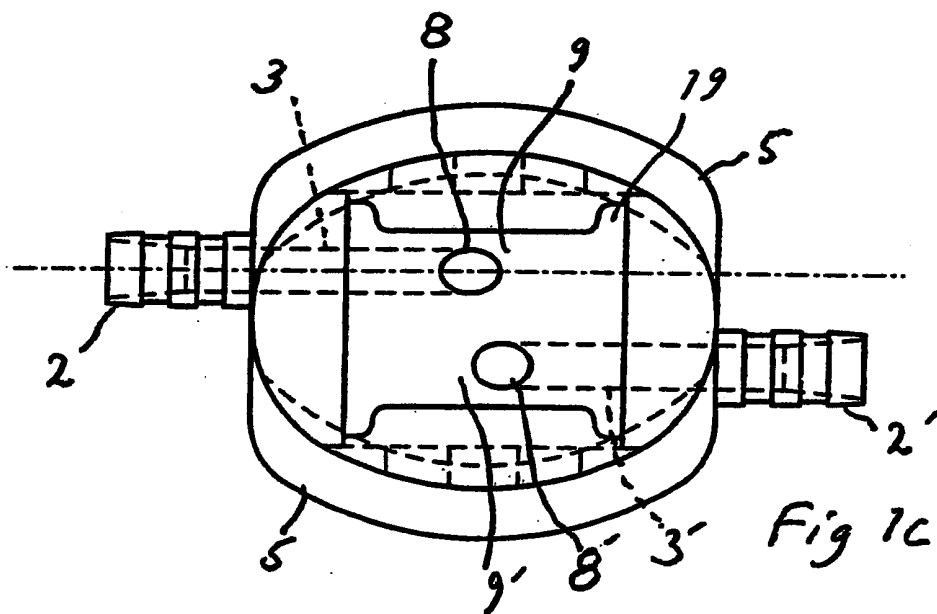
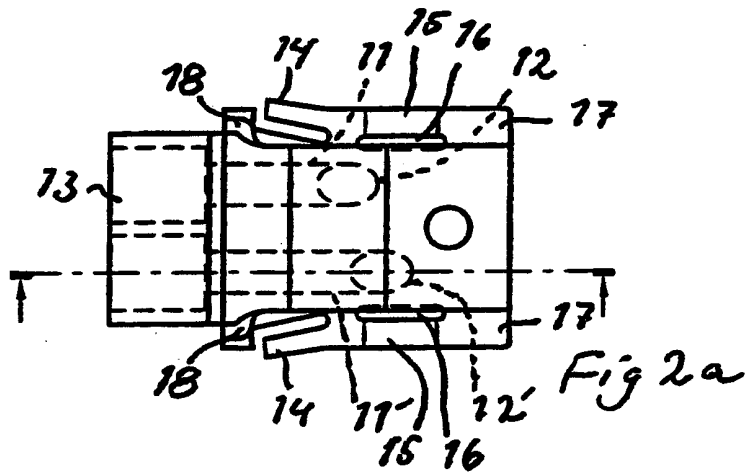
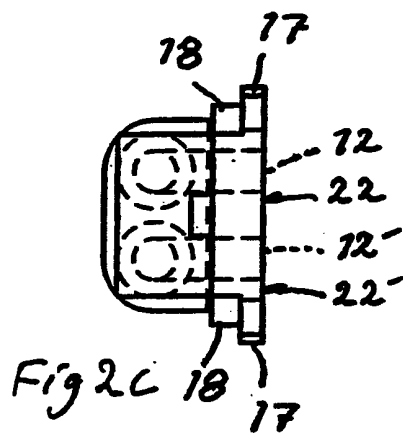
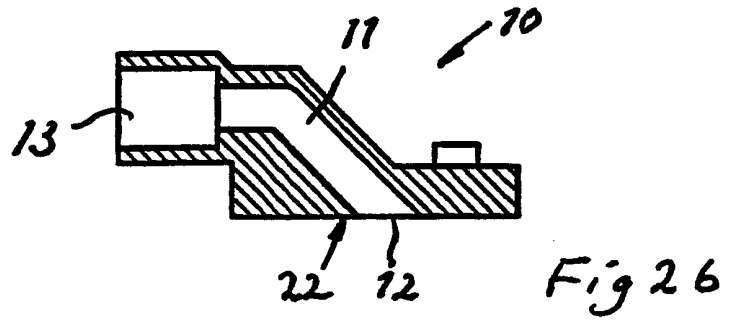
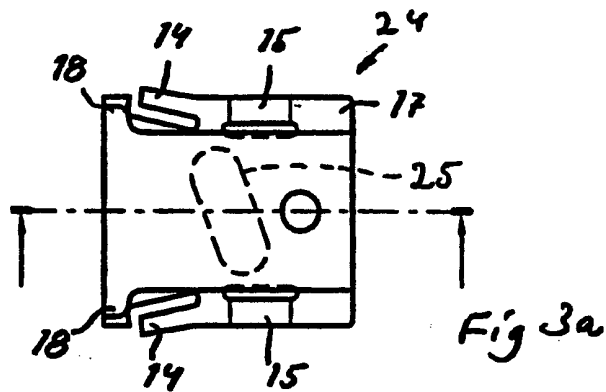
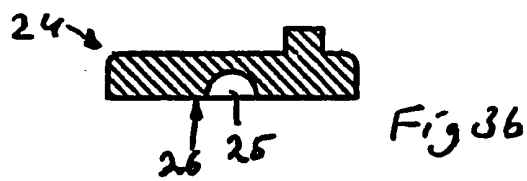
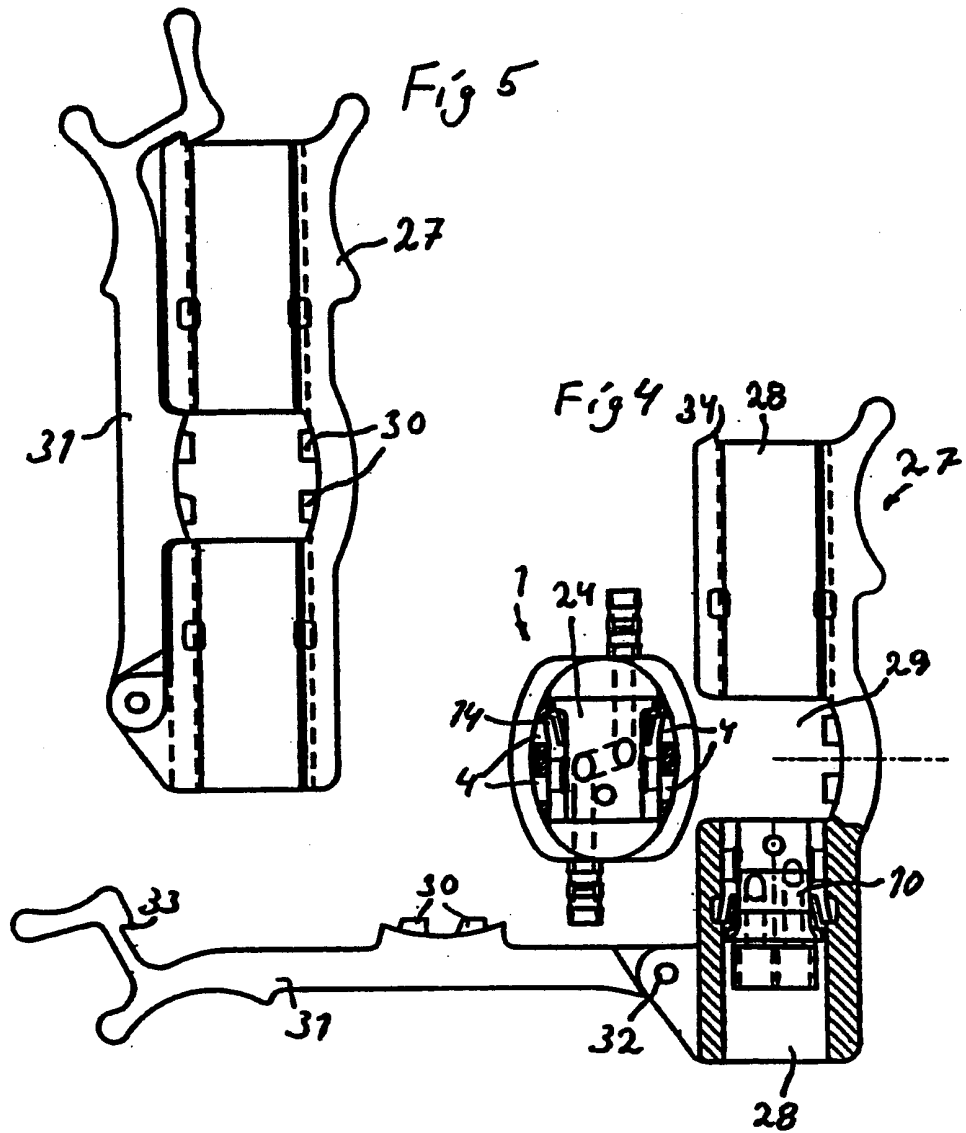
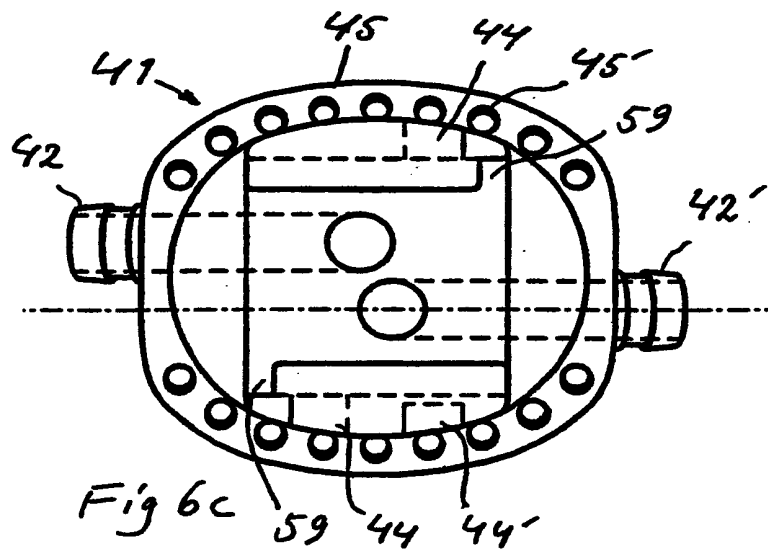
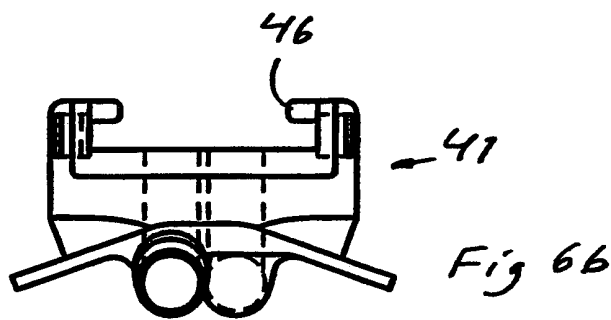
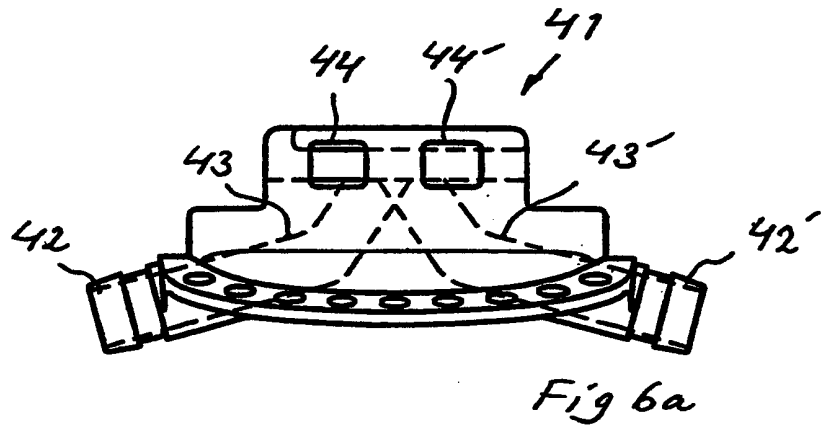
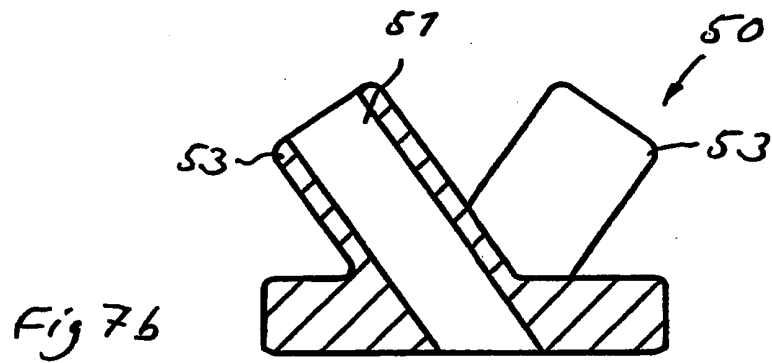
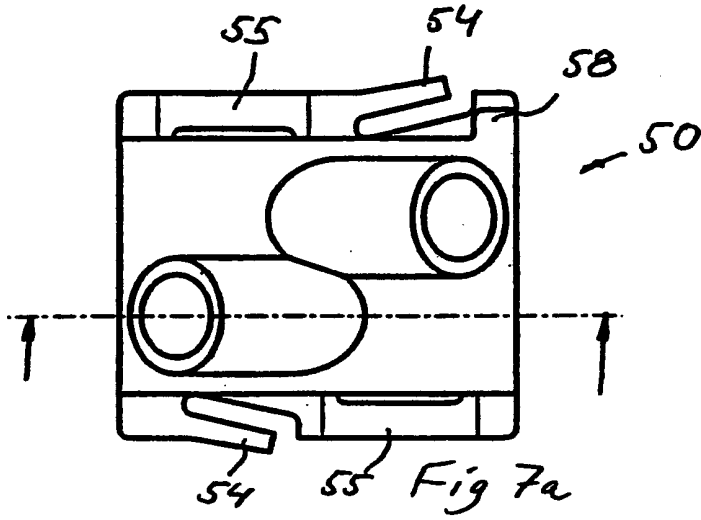

Fig 1c









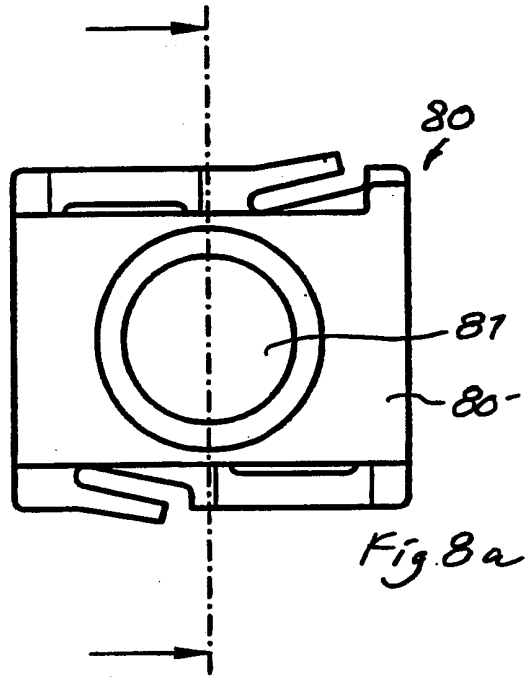

Fig. 8a

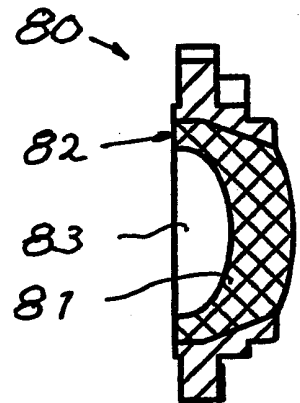

Fig. 8c

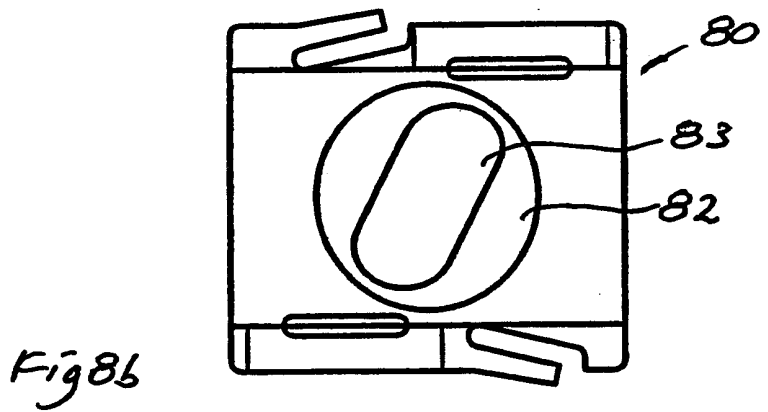
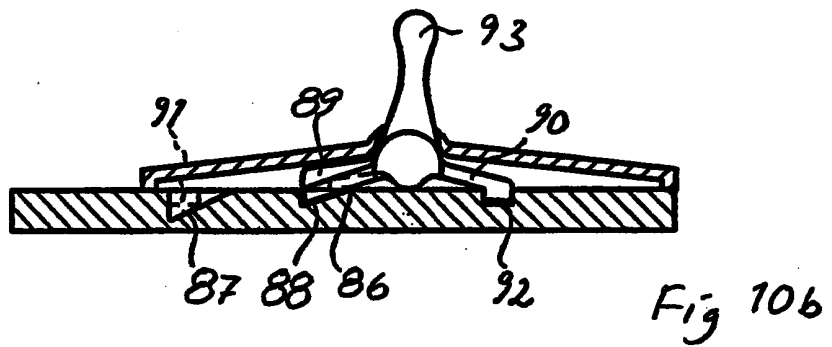
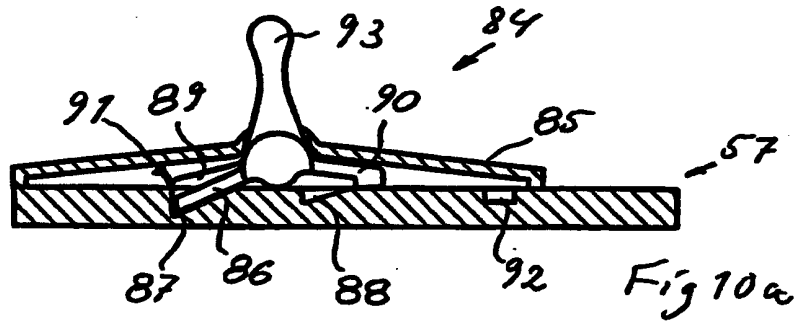
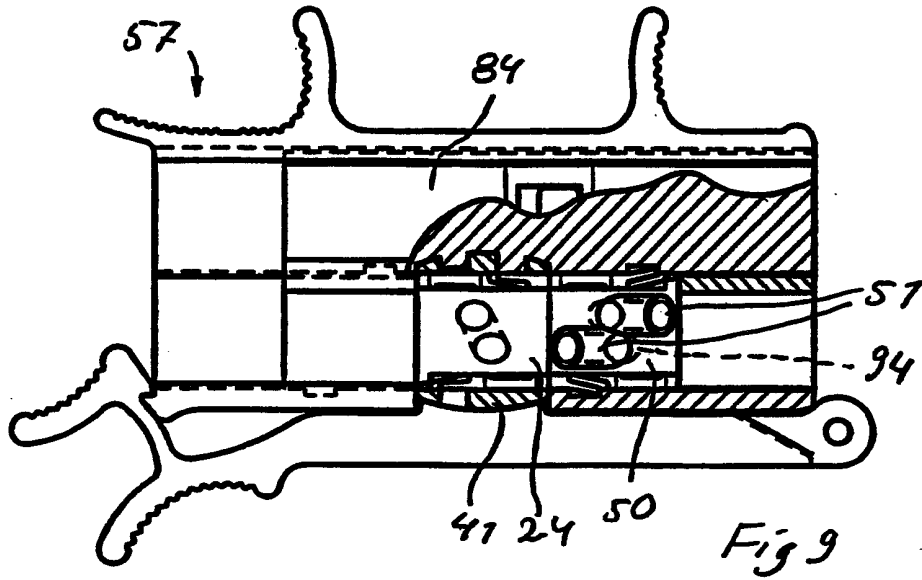

Fig. 8b



INTERNATIONAL SEARCH REPORT

International application No.

PCT/SE 98/01880

A. CLASSIFICATION OF SUBJECT MATTER

IPC6: A61M 39/02, A61M 39/00, A61M 1/00

According to International Patent Classification (IPC) or to both national classification and IPC

B. FIELDS SEARCHED

Minimum documentation searched (classification system followed by classification symbols)

IPC6: A61M

Documentation searched other than minimum documentation to the extent that such documents are included in the fields searched

SE,DK,FI,NO classes as above

Electronic data base consulted during the international search (name of data base and, where practicable, search terms used)

WPI

C. DOCUMENTS CONSIDERED TO BE RELEVANT

Category*	Citation of document, with indication, where appropriate, of the relevant passages	Relevant to claim No.
A	WO 9213590 A1 (HEMAPURE AB), 20 August 1992 (20.08.92), page 3, line 25 - page 5, line 2 --	1-18
A	US 4983162 A (J. METAIS ET AL.), 8 January 1991 (08.01.91), figures 9-12, abstract --	1-18
A	US 4108173 A (V. SLIVENKO ET AL.), 22 August 1978 (22.08.78), figure 1, abstract -- -----	1-18

Further documents are listed in the continuation of Box C.

See patent family annex.

* Special categories of cited documents:

"A" document defining the general state of the art which is not considered to be of particular relevance

"E" earlier document but published on or after the international filing date

"L" document which may throw doubts on priority claim(s) or which is cited to establish the publication date of another citation or other special reason (as specified)

"O" document referring to an oral disclosure, use, exhibition or other means

"P" document published prior to the international filing date but later than the priority date claimed

"T" later document published after the international filing date or priority date and not in conflict with the application but cited to understand the principle or theory underlying the invention

"X" document of particular relevance: the claimed invention cannot be considered novel or cannot be considered to involve an inventive step when the document is taken alone

"Y" document of particular relevance: the claimed invention cannot be considered to involve an inventive step when the document is combined with one or more other such documents, such combination being obvious to a person skilled in the art

"&" document member of the same patent family

Date of the actual completion of the international search

12 January 1999

Date of mailing of the international search report

27 -01- 1999

Name and mailing address of the ISA/

Swedish Patent Office
Box 5055, S-102 42 STOCKHOLM
Facsimile No. +46 8 666 02 86

Authorized officer

Eva Selin
Telephone No. +46 8 782 25 00

INTERNATIONAL SEARCH REPORT

Information on patent family members

01/12/98

International application No.

PCT/SE 98/01880

Patent document cited in search report	Publication date	Patent family member(s)	Publication date
WO 9213590 A1	20/08/92	AT 125453 T	15/08/95
		AU 647587 B	24/03/94
		AU 1152492 A	07/09/92
		BR 9107267 A	14/06/94
		CA 2100789 A	31/07/92
		CZ 281388 B	11/09/96
		DE 69107070 D,T	24/05/95
		DE 69111620 D,T	11/01/96
		DK 570440 T	06/11/95
		EP 0527899 A,B	24/02/93
		EP 0570440 A,B	24/11/93
		ES 2075683 T	01/10/95
		FI 933317 A	23/07/93
		GR 3017844 T	31/01/96
		HU 66155 A	28/09/94
		JP 2742961 B	22/04/98
		JP 6504933 T	09/06/94
		LT 665 A	31/01/95
		LT 3410 B	25/09/95
		LV 10060 A,B	10/05/94
		NO 179603 B,C	05/08/96
		PL 168205 B	31/01/96
		SE 467769 B,C	14/09/92
		SE 9100291 A	31/07/92
		SK 78093 A	08/12/93
		SK 278707 B	14/01/98
		US 5415668 A	16/05/95
		US 5474526 A	12/12/95
US 4983162 A	08/01/91	EP 0318358 A	31/05/89
		FR 2623405 A	26/05/89
US 4108173 A	22/08/78	CA 1124603 A	01/06/82
		DE 2815449 A	12/10/78
		FR 2387044 A,B	10/11/78
		GB 1582522 A	07/01/81
		JP 53126790 A	06/11/78