

F. B. Hunt, Cider Mill.

N^o 26,818.

Patented Jan. 10, 1860.

Fig. 2.

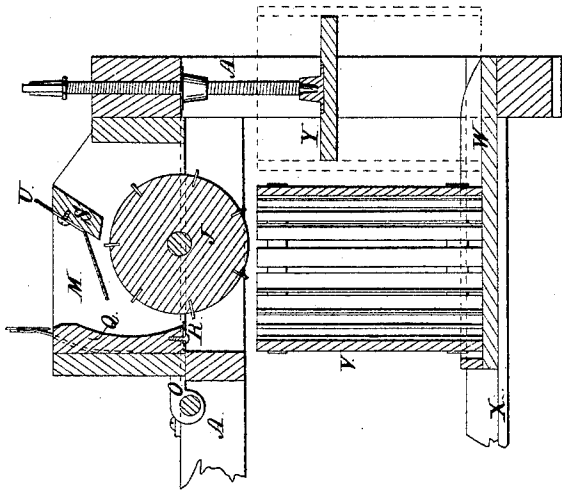

Fig. 4.

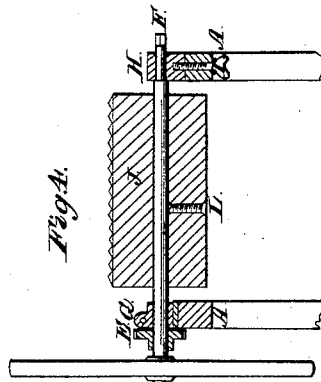

Fig. 1.

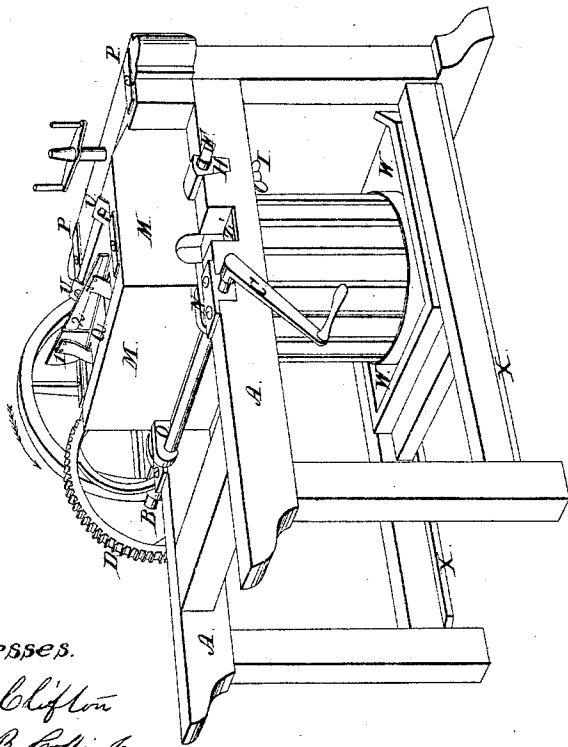
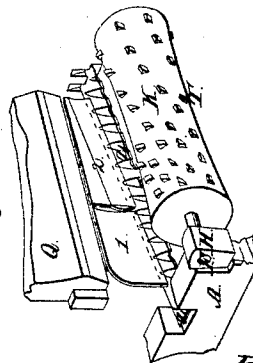

Fig. 3.



Witnesses.

H. C. Clifton
J. P. B. Coffin Jr

Inventor.

Franklin B. Hunt.

UNITED STATES PATENT OFFICE.

FRANKLIN B. HUNT, OF CINCINNATI, OHIO, ASSIGNOR TO R. D. VAN DEURSEN AND IRA B. GIBBS, OF SAME PLACE.

MILL.

Specification of Letters Patent No. 26,818, dated January 10, 1860.

To all whom it may concern:

Be it known that I, FRANKLIN B. HUNT, of Cincinnati, in the county of Hamilton and State of Ohio, have invented a new and useful Improvement in Combined Cider-Mills and Corn-Shellers; and I do hereby declare that the following is a full and exact description thereof, reference being had to the accompanying drawings, and to the letters of reference marked thereon, making part of this specification.

The nature of my invention relates, 1st, to the employment of a reversible block, constructed, and arranged in combination with a grinding cylinder and a shelling cylinder respectively, as and for the purposes hereinafter represented and described; 2nd, to the employment of adjustable feed-plates in combination with the said reversible block, said grinding and shelling cylinders, and a secondary frame substantially in the manner and for the purposes hereinafter represented and described; 3d, to the combination of several parts, constructed, and arranged to operate conjointly, and denominated the cylinder-carrier, as and for the purposes hereinafter represented and described.

With reference to the accompanying drawings Figure 1, is a perspective representation of the improved machine. Fig. 2, is a sectional view; the plane of section passing vertically and longitudinally through the machine. Fig. 3, is a perspective view of the shelling-cylinder, and other details in their proper relative position for operation. Fig. 4, is a sectional view of the cylinder carrier, and the grinding-cylinder.

A, is the frame, upon which is arranged the shaft B, in suitable bearings. This shaft is furnished with the crank C, to which the power is applied to drive the machine, and also with the gear wheel D, which is arranged to play into the pinion E, on shaft F. The shaft F, is arranged in the hinge-bearing G, on one side of the frame and in the removable bearing H, at the other side, these bearings with shaft F, and the screw-bolt I, comprise what I have denominated the cylinder-carrier.

J, is the cylinder for grinding apples, its construction being that of a plain cylinder into the surface of which is fixed the series of serrated plates as seen in Figs. 2, and 4, the serrated portion only of the plates projecting above the surface.

K, is the cylinder for shelling corn the construction of which will be best understood by reference to the drawing. Both of these cylinders are fitted to the shaft, F, and furnished with set-screws by which they may be fastened to, or released therefrom at pleasure. When it is required to change the cylinders, as for instance after grinding apples with cylinder J, to substitute cylinder K, for the purpose of shelling corn, it is necessary simply to release the bearing H, by unscrewing the screw-bolt I, and the set-screw L, being loosened, the shaft F, may be turned up on its hinge G, and both cylinder, and bearing H, removed, the other cylinder is then slipped on in its place the bearing H, and screw I, replaced, and the set-screw T, tightened up.

A secondary frame M, is hinged to frame A, by the hinges N, O, through which is passed the shaft B; its opposite end being fastened down by means of the buttons P, these buttons are released and the frame M, turned up, when it is required to change the cylinders as described. In the frame M, is fitted the reversible block Q, which for the purpose of shelling corn is arranged as shown in Fig. 3, and for grinding apples as in Fig. 2, the plate R, on its lower edge in Fig. 2, is made adjustable with reference to the points of the serrated plates in cylinder J, and should be so set that said points must pass very nearly in contact with it.

A bar S, is arranged as shown across the frame M, and on it are arranged the plates U, made adjustable by means of screws which secure them to bar S, so that one or more of them may be used to adjust the feeding capacity of the feeding mouth formed by the secondary frame M, bar S, block Q, and cylinder S, or K. This variable capacity of the feeding mouth is useful to adapt the machine to the different degrees of power which it may be convenient at different times to employ in driving it.

When grinding apples they fall from cylinder J, into the press-hoop V, until it is properly filled when it with the juice-pan W, is slid along upon the ways X, under the screw and follower Y, as indicated by dotted lines, and the pressing effected thereby in the usual manner, after which the pomace being removed and the press hoop V, and juice pan W, replaced, the grinding proceeds as before, the cylinder rotating in all

cases in the direction indicated by the arrow, Fig. 1, and the apples being drawn thereby between it and the block Q, and its plate R, thus securing the requisite perfection of grinding.

When the machine is arranged for shelling corn the serrated bar Z, is arranged as seen in Fig. 3, with an inclination toward Z', the point of delivery of the cob. The sectional pressure bar 1, 2, serves to keep the ear of corn in contact with the teeth of the cylinder K, with suitable pressure to effect the shelling as it is drawn by the cylinder down in contact with bar Z, and the two sections operating separately serve more effectually to retain the ear until the corn is entirely removed.

The several parts, may be made of such suitable materials as are usually employed for similar purposes.

Having described the construction and operation of my invention, what I claim therein as new and, desire to secure by Letters Patent is as follows.

1. I claim the reversible block (Q), secondary frame (M) and cylinder carrier (F, G, H), constructed and arranged for the use of different cylinders substantially as described.

2. In combination with the above arrangement of parts I claim the feed plates (U) constructed and arranged to operate substantially as described.

In testimony of which invention I have hereunto set my hand in presence of witnesses.

FRANKLIN B. HUNT.

Witnesses:

H. E. CLIFTON,

D. N. B. COFFIN, Jr.