



US 20060219718A1

(19) **United States**

(12) **Patent Application Publication**
Finnestad

(10) **Pub. No.: US 2006/0219718 A1**

(43) **Pub. Date: Oct. 5, 2006**

(54) **INTEGRAL TORTUOUS PATH RECEPTACLE COVER**

(52) **U.S. Cl. 220/254.3**

(75) **Inventor: M. Brian Finnestad, Huntley, IL (US)**

(57) **ABSTRACT**

Correspondence Address:

RATNERPRESTIA

P O BOX 980

VALLEY FORGE, PA 19482-0980 (US)

(73) **Assignee: Sherwood Services, AG**

A cover for a medical waste disposal receptacle and a method of manufacturing a cover for a medical waste disposal receptacle. The cover generally comprises a body portion configured to substantially close an open end of the receptacle and a lid portion hingedly interconnected to the body portion via an integrally formed hinge extending between the lid portion and a portion of the body portion. The body portion includes a covering surface with an access opening therethrough and at least a first, fixed sloped slide surface depending from the covering surface configured to provide a fixed tortuous path extending from the access opening.

(21) **Appl. No.: 11/099,072**

(22) **Filed: Apr. 5, 2005**

Publication Classification

(51) **Int. Cl.**
B65D 51/18 (2006.01)

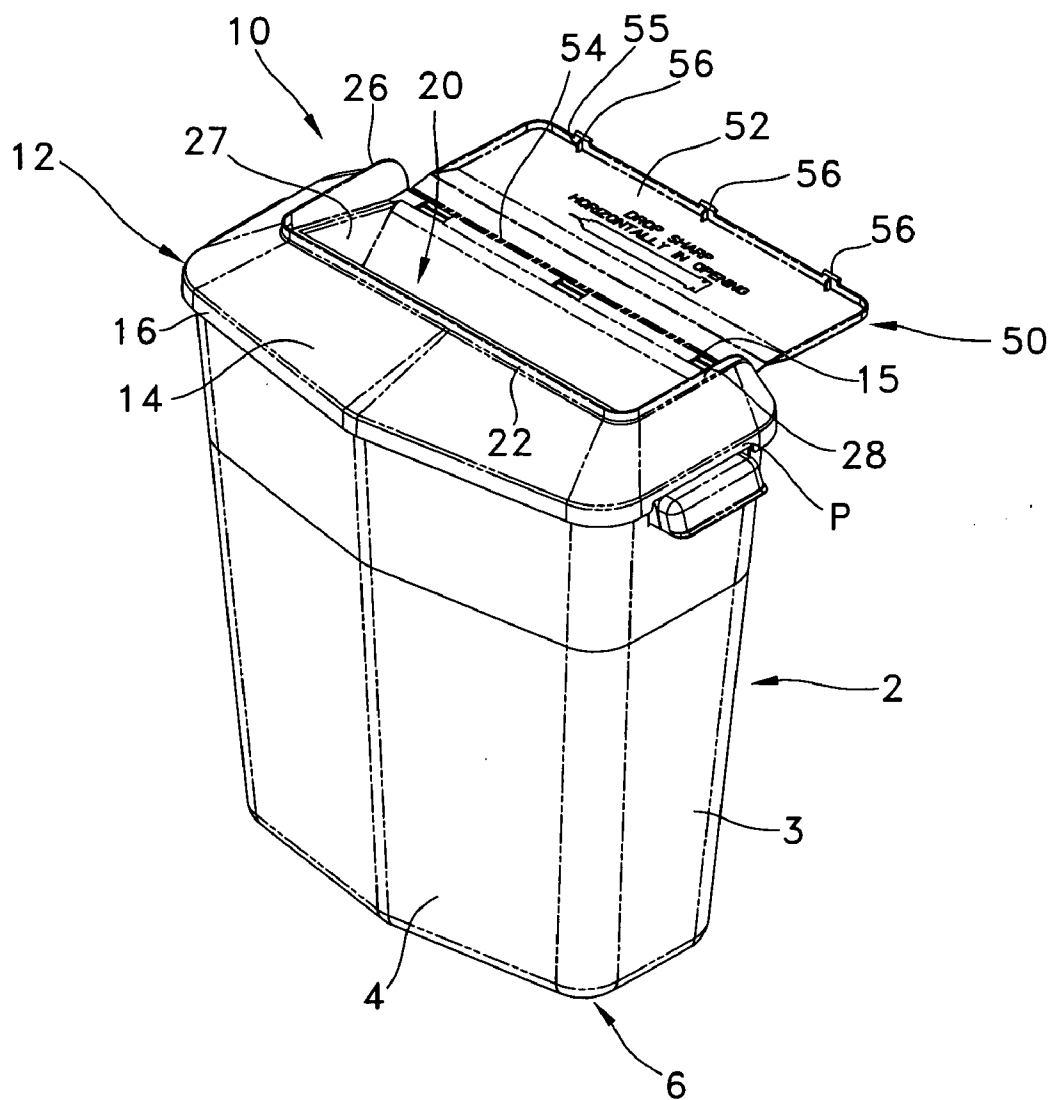

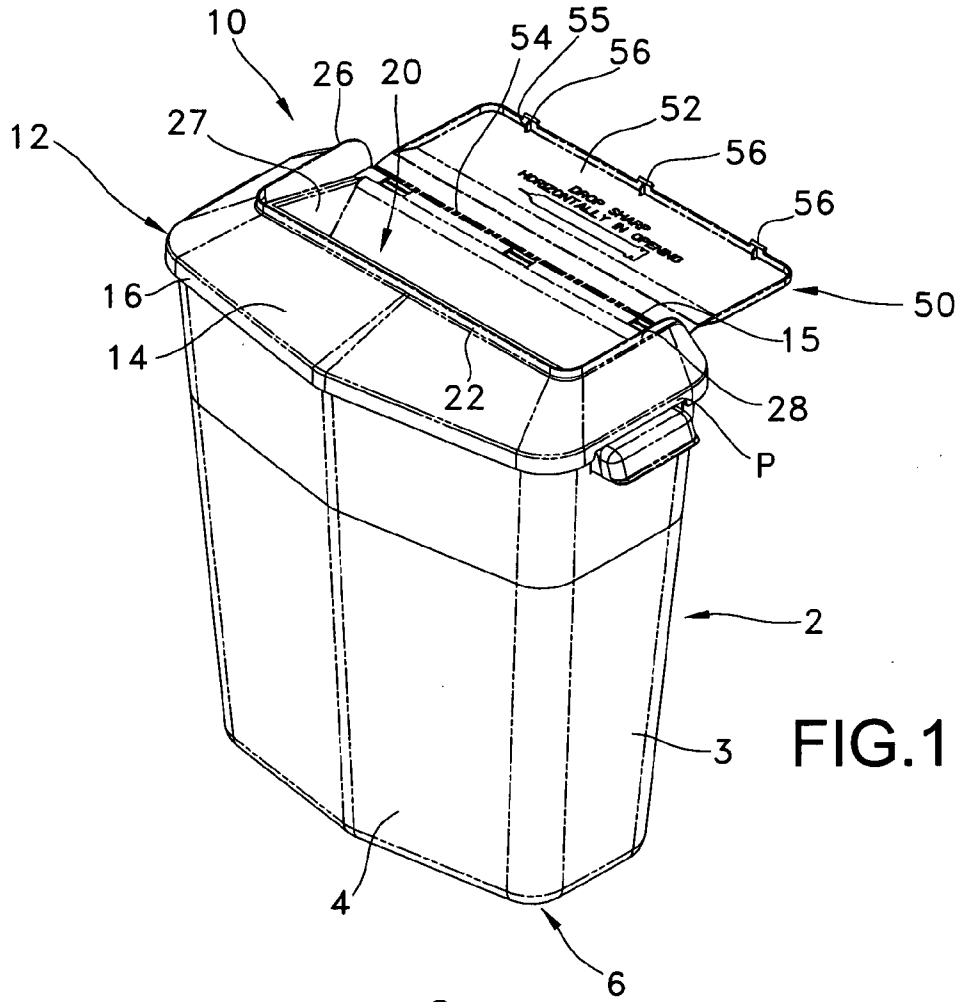

FIG. 1

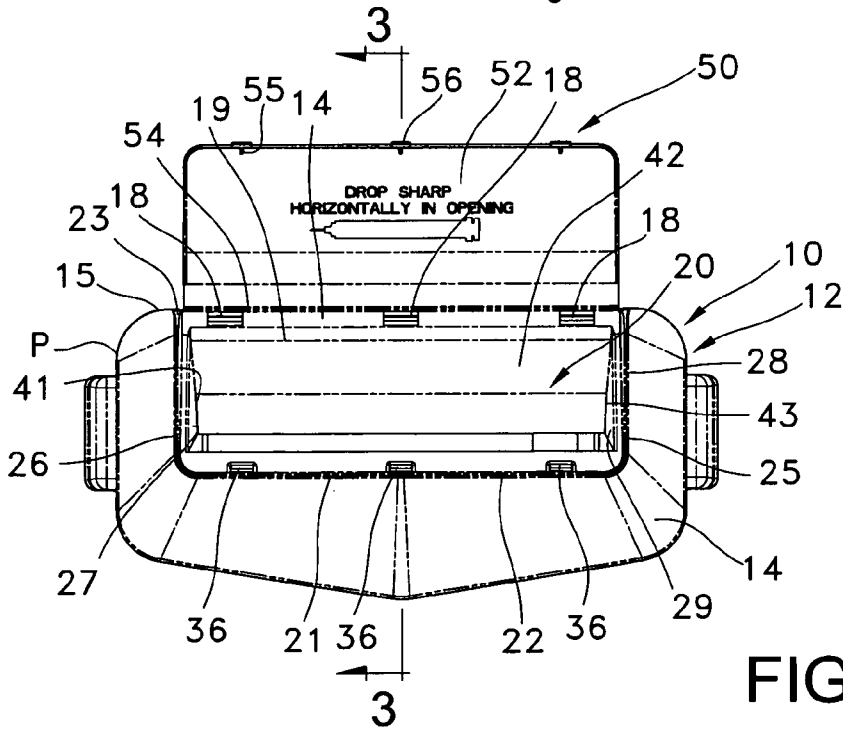
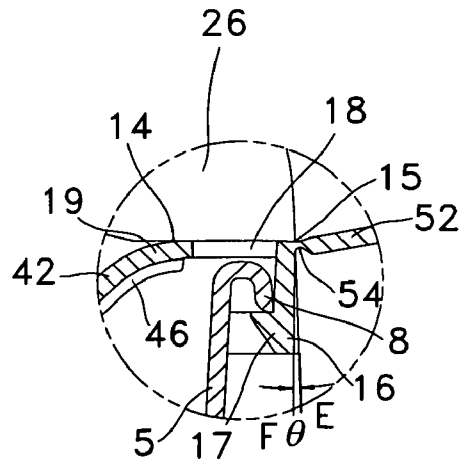
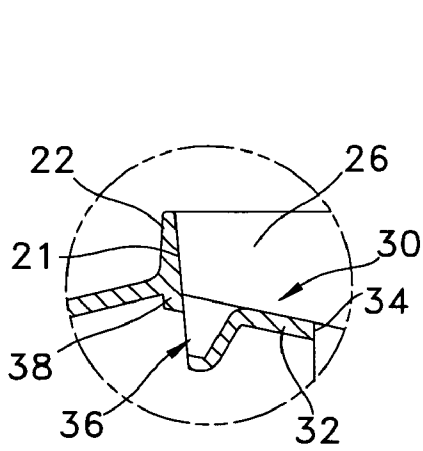
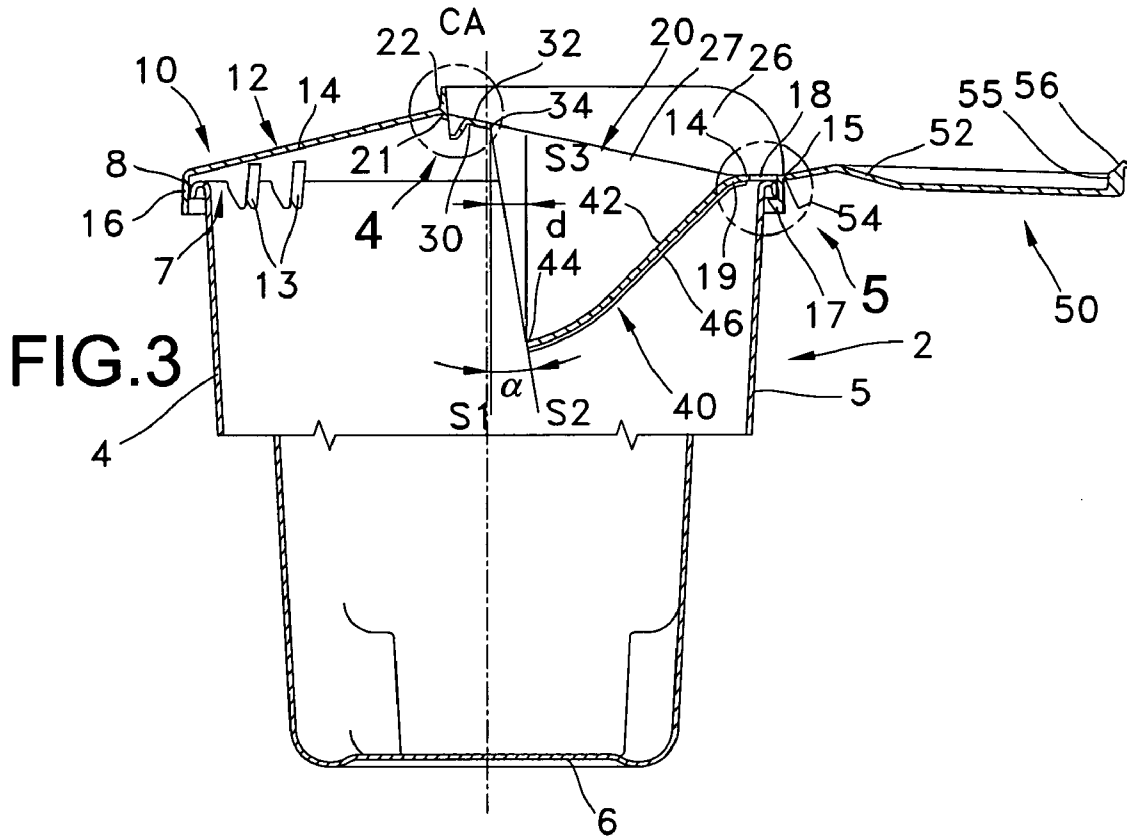
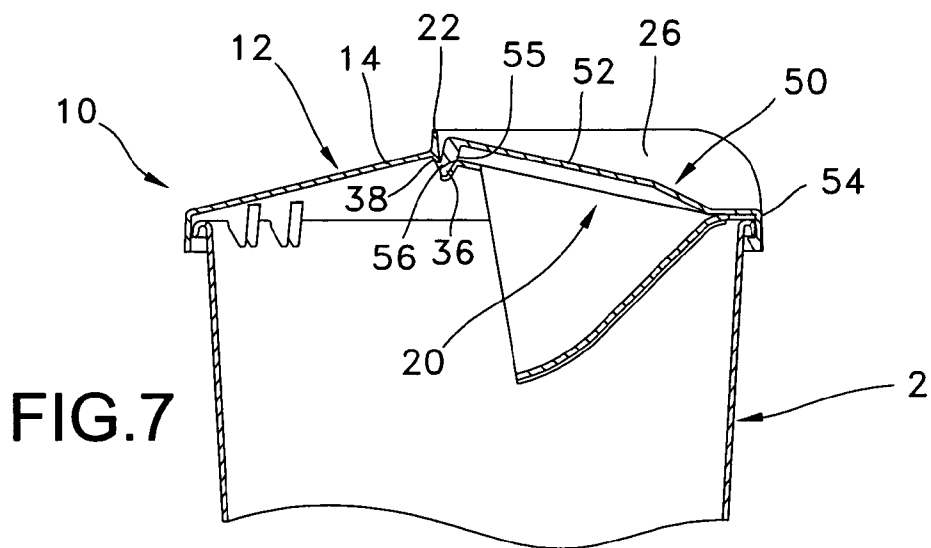
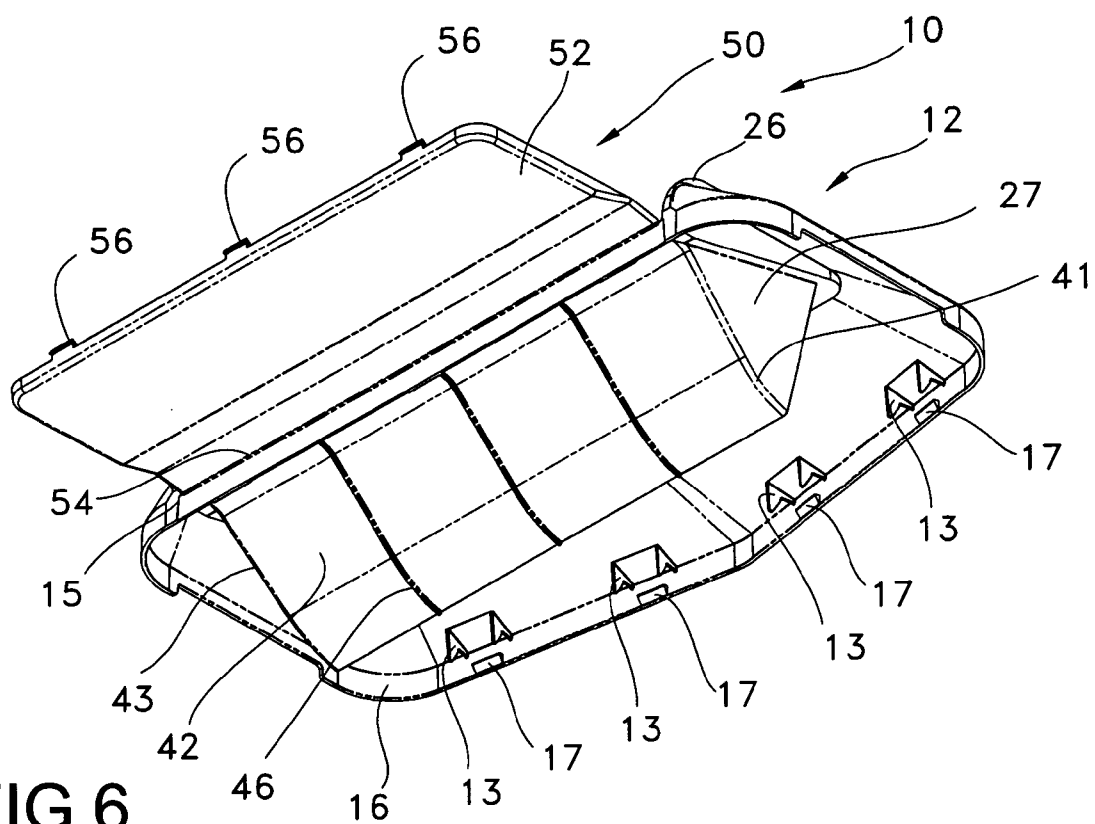
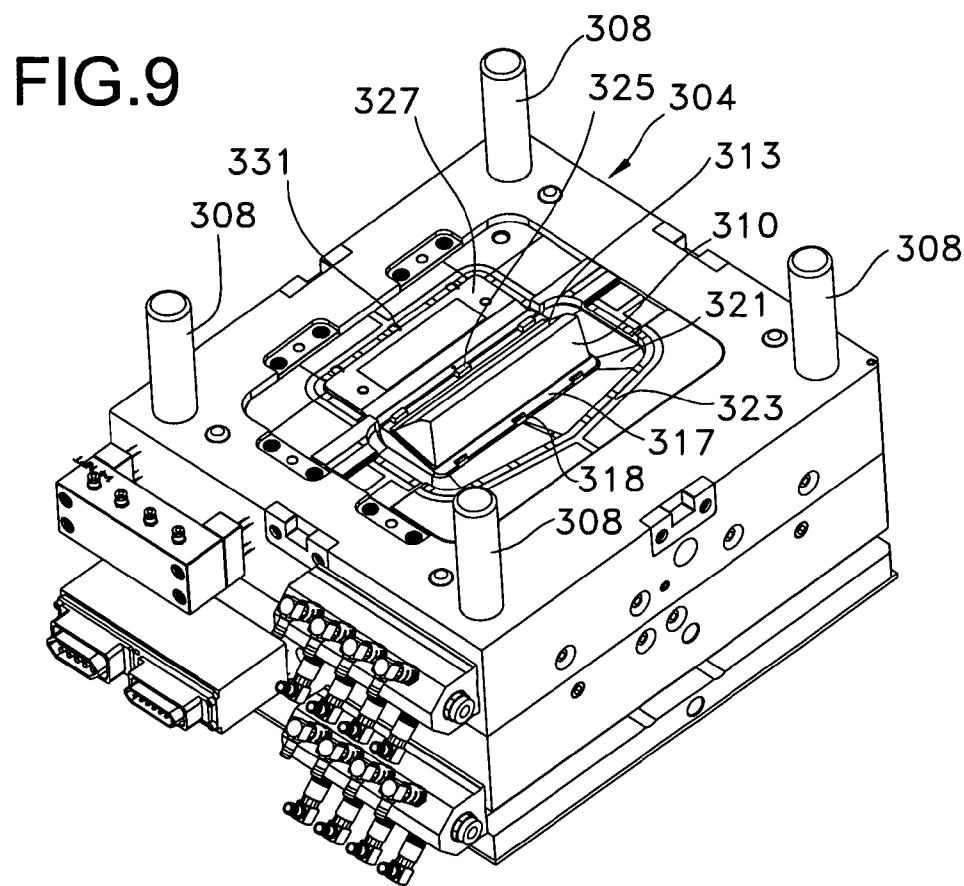
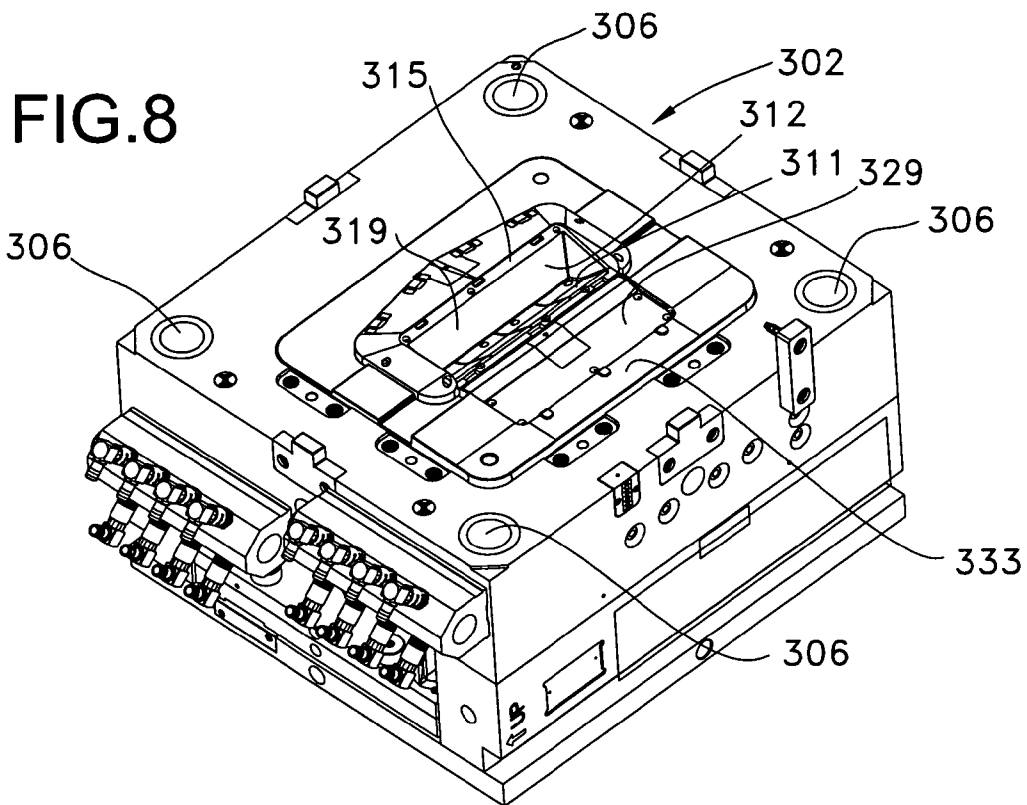

FIG. 2







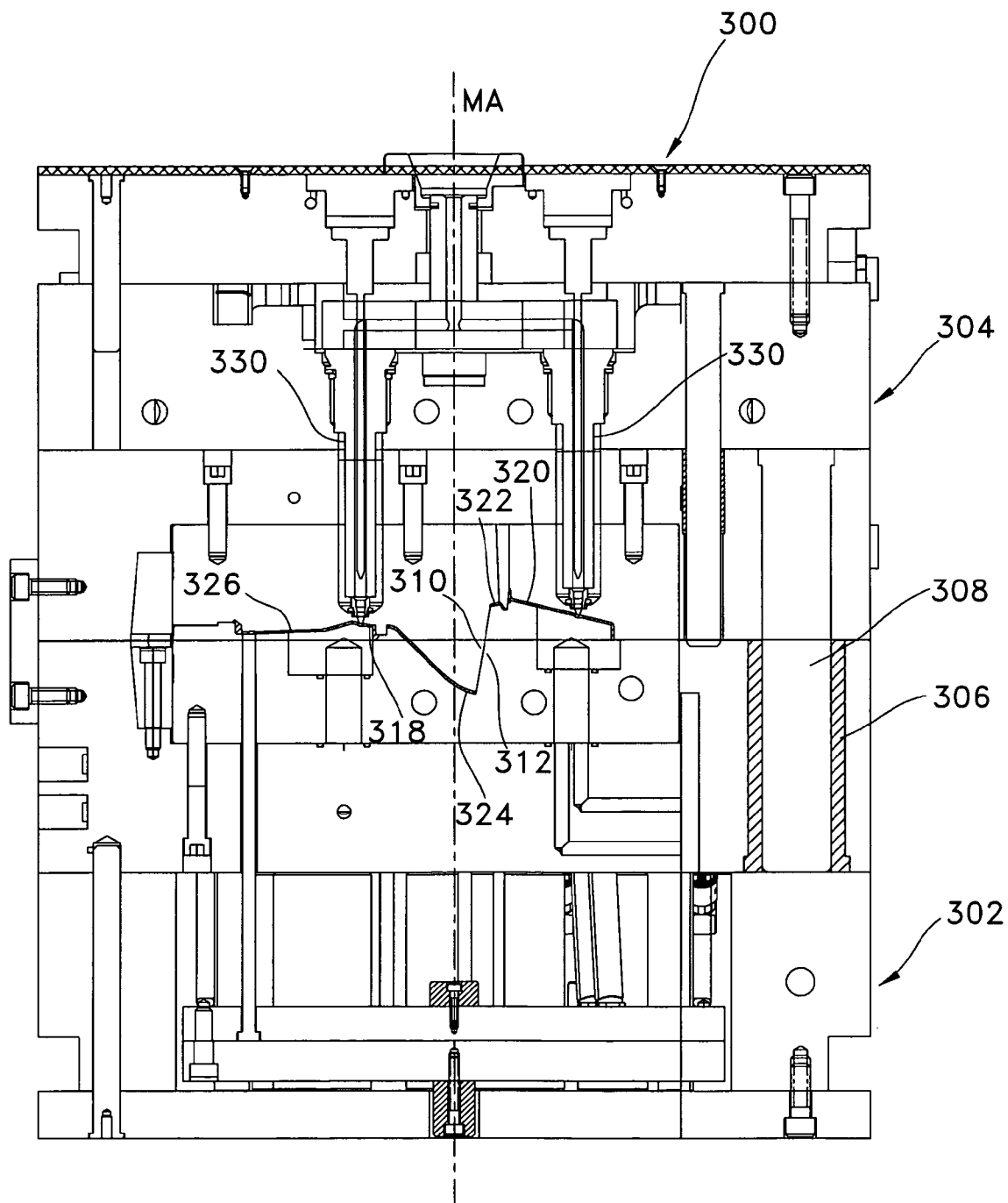

FIG. 10

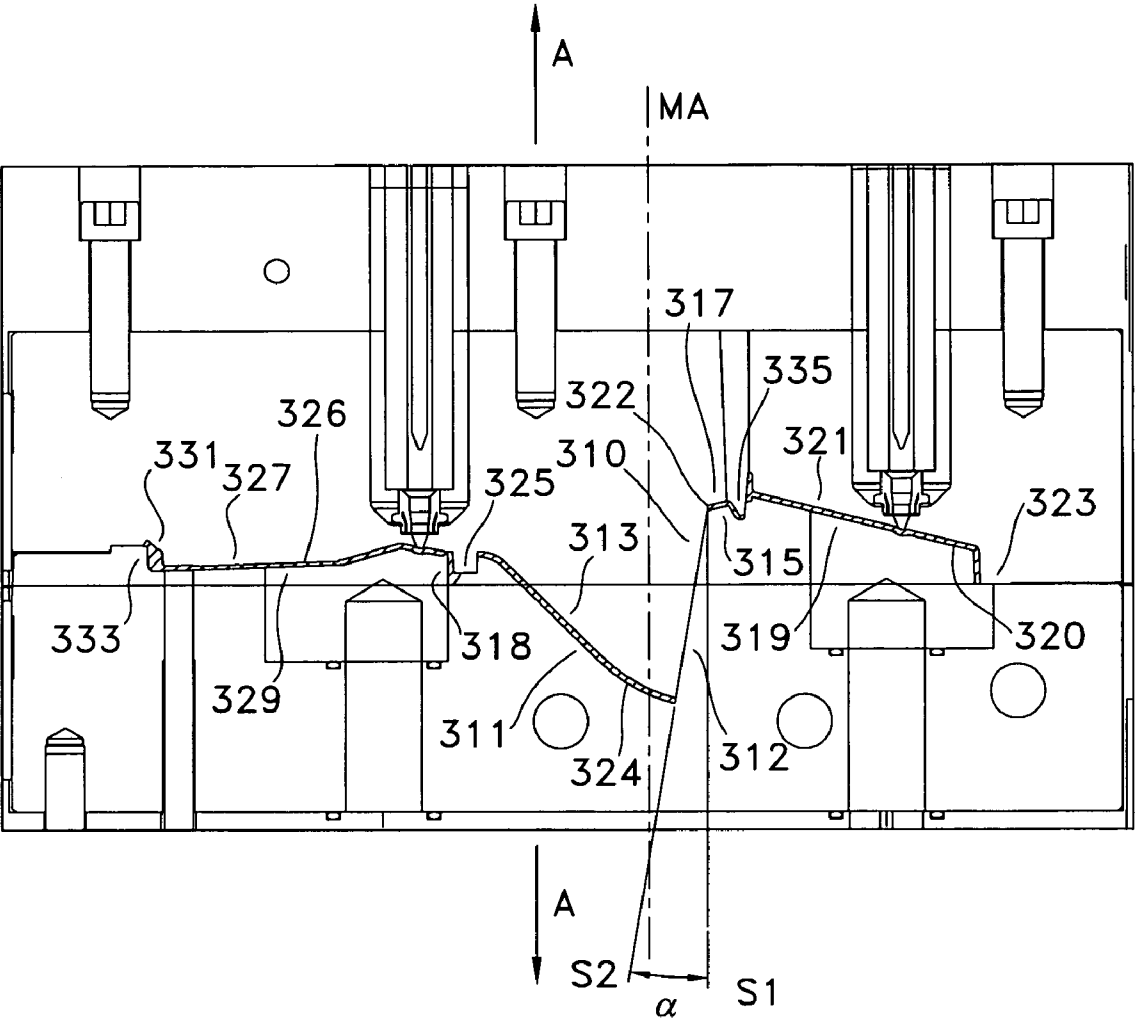

FIG.11

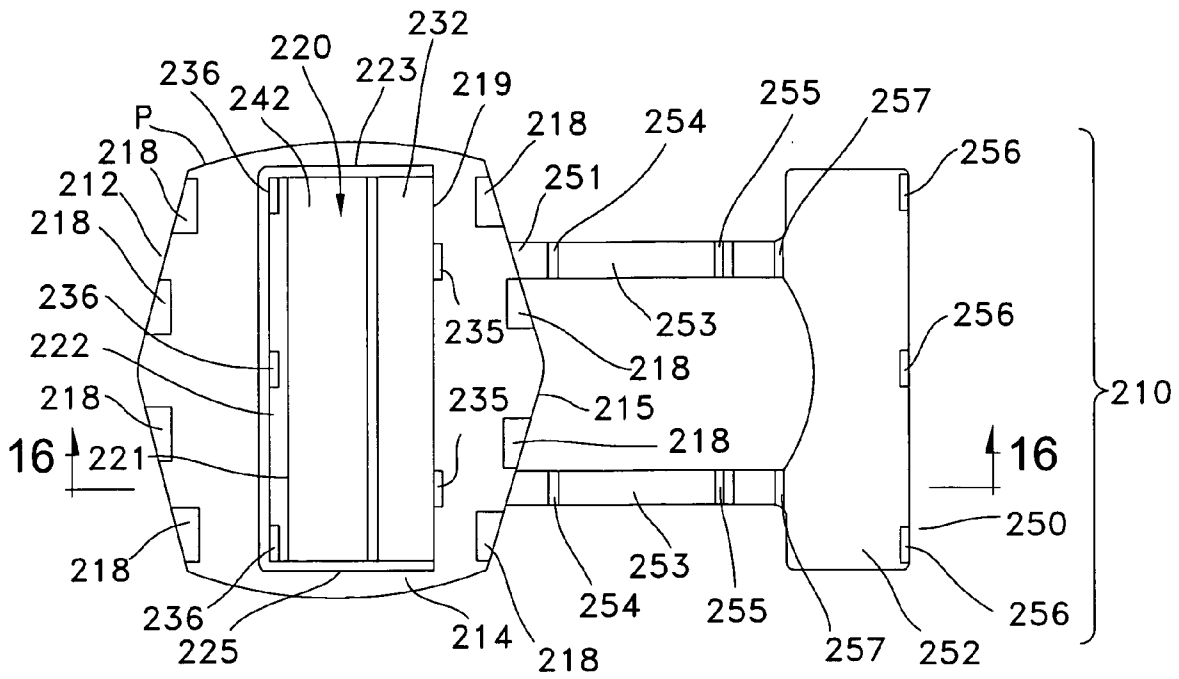

FIG. 15

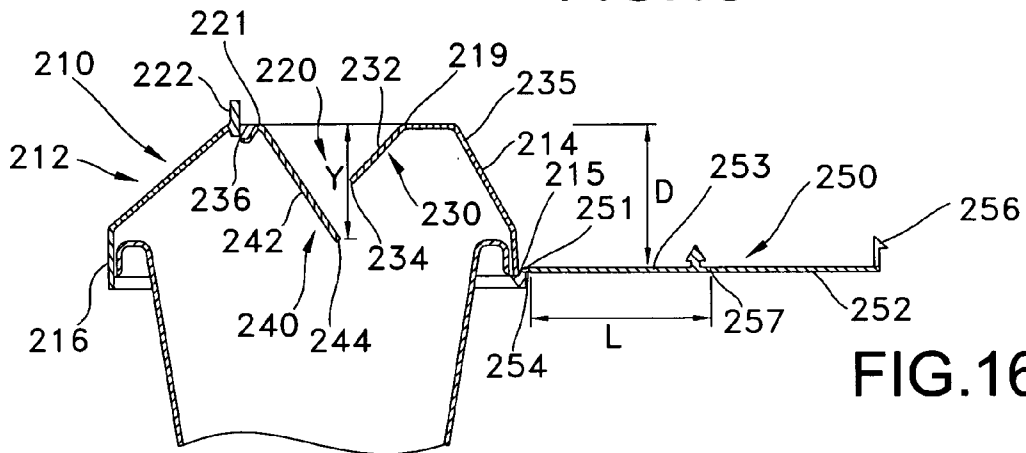

FIG. 16

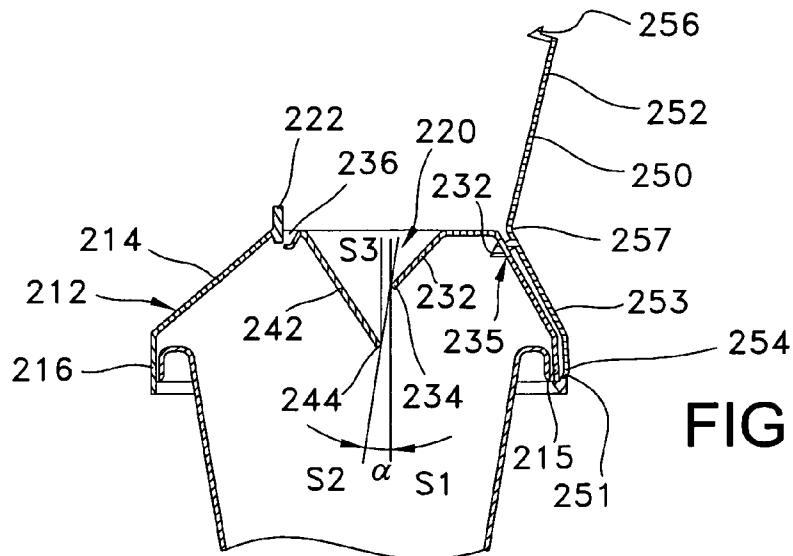

FIG. 17

INTEGRAL TORTUOUS PATH RECEPTACLE COVER

BACKGROUND OF THE INVENTION

[0001] The present invention relates to a cover for a medical waste disposal receptacle and a method of manufacturing a cover for a medical waste disposal receptacle. More specifically, the present invention relates to medical waste disposal receptacles having a flexibly pivoted top closure lid and, more particularly, to a receptacle cover having an integral pivoted lid portion and a body portion having an integral tortuous path access opening.

[0002] Various types of containers for hospital use have been developed for receiving medical waste in a surgical operating room, pre-op or post-op room, a patient's room, or in other clinical or non-clinical settings in which medical waste is generated. These containers are particularly designed to protect the user of such containers, such as doctors, nurses, or other hospital personnel, from the hospital waste products that may be disposed therein. Such hospital waste products might include surgical sharps, such as needles, syringes, scalpel blades, or the like, or might include gauzes, bandages, or sponges. It is important to prevent the user of a sharps container from being accidentally cut or punctured by its contents.

[0003] Examples of such containers include those shown in U.S. Pat. No. 5,058,764, entitled "Mounting Bracket Having A Hidden Lock For A Sharps Collection System"; U.S. Pat. No. 5,080,251, entitled "Tortuous Path In-Patient Room Medical Waste Disposal Container"; and U.S. Pat. No. 5,494,186, entitled "Wall Mounted Medical Waste Disposal Container With Pivoted Top Closure Lid."

[0004] While the prior art containers provide a desired level of protection, they generally require various components to be formed separately and thereafter assembled. These additional steps add cost and complexity to the manufacturing process.

SUMMARY OF THE INVENTION

[0005] In at least one embodiment, the cover comprises a body portion configured to substantially close an open end of the receptacle. The body portion has a given perimeter and defines a tortuous path access opening. A lid portion configured to selectively close the access opening is hingedly interconnected to the body portion via an integrally formed hinge extending between the lid portion and a portion of the body portion given perimeter.

[0006] In at least one embodiment, the cover comprises a body portion including a covering surface configured to substantially close the receptacle open end. The body portion further includes first and second slide surfaces depending from the covering surface. The first and second slide surfaces are axially spaced in non-overlapping relation to define a tortuous path access opening through the covering surface.

[0007] In at least one embodiment, the receptacle includes an open end and a receptacle body having an axis extending from the open end in a given direction and the cover comprises a body portion configured to substantially close the open end of the receptacle. The body portion defines a tortuous path access opening having opposed, axially

spaced, first and second lateral edges. The body portion includes at least a first integral slide surface that defines the first lateral edge. The first and second lateral edges are configured such that a plane extending through the first and second lateral edges is at an angle of between 0 degrees and about 20 degrees relative to a plane parallel to the given direction and extending through the second lateral edge.

[0008] The method, according to one exemplary embodiment, comprises the steps of disposing a moldable material in a linearly separable mold assembly having one or more cavities configured to define the tortuous path receptacle cover, and removing the integrally formed cover from the mold assembly.

BRIEF DESCRIPTION OF THE DRAWINGS

[0009] The invention is best understood from the following detailed description when read in connection with the accompanying drawings. It is emphasized that, according to common practice, the various features of the drawings are not to scale. On the contrary, the dimensions of the various features are arbitrarily expanded or reduced for clarity. Included in the drawings are the following figures:

[0010] **FIG. 1** is a top, front isometric view of a cover that is a first embodiment of the present invention positioned on an illustrative receptacle.

[0011] **FIG. 2** is a top plan view of the cover of **FIG. 1**.

[0012] **FIG. 3** is a cross-sectional view along the line 3—3 in **FIG. 2**.

[0013] **FIG. 4** is a detailed view of a lock portion of the cover as denoted in **FIG. 3**.

[0014] **FIG. 5** is a detailed view of a hinge portion of the cover as denoted in **FIG. 3**.

[0015] **FIG. 6** is a bottom, front isometric view of the cover of **FIG. 1**. **FIG. 7** is a cross-sectional view similar to **FIG. 3** showing a lid portion in a closed position.

[0016] **FIG. 8** is an isometric view of a first portion of an embodiment of a mold assembly utilized to manufacture the cover of **FIG. 1**.

[0017] **FIG. 9** is an isometric view of a second portion of the mold assembly utilized to manufacture the cover of **FIG. 1**.

[0018] **FIG. 10** is a cross-sectional side view showing the first and second mold portions of **FIGS. 8 and 9** in an assembled configuration.

[0019] **FIG. 11** is a detailed view of the cavity portions of the mold assembly of **FIG. 10**.

[0020] **FIG. 12** is a top, front isometric view of a cover that is a second embodiment of the present invention.

[0021] **FIG. 13** is a top plan view of the cover of **FIG. 12**.

[0022] **FIG. 14** is a cross-sectional side view along the line 14—14 in **FIG. 13**.

[0023] **FIG. 15** is a top plan view of a cover that is a third embodiment of the present invention.

[0024] **FIG. 16** is a cross-sectional side view along the line 16—16 in **FIG. 15**.

[0025] FIG. 17 is a cross-sectional side view similar to FIG. 16 showing the lid portion in an operable position.

DETAILED DESCRIPTION OF THE INVENTION

[0026] This invention will now be described with reference to several embodiments selected for illustration in the drawings. It will be appreciated that the scope and spirit of the invention are not limited to the illustrated embodiments. It will further be appreciated that the drawings are not rendered to any particular proportion or scale. Also, any dimensions referred to in the description of the illustrated embodiments are provided merely for the purpose of illustration. The invention is not limited to any particular dimensions, materials, or other details of the illustrated embodiments.

[0027] Referring to FIGS. 1-7, a cover 10 that is a first embodiment of the present invention will be described. The cover 10 is configured to be positioned on a medical waste disposal receptacle 2. The receptacle 2 generally includes a body defined by a front wall 4, a pair of side walls 3, and a rear wall 5 extending from a base 6. The walls 3, 3, 4 and 5 define a generally open end 7 opposite the base 6. The open end 7 defines a rim 8 about its perimeter. The rim 8 may have various configurations. As shown in FIG. 3, the edges of the walls 3, 3, 4 and 5 are curled over to define the rim 8, however, a curl is not required and other configurations may be utilized.

[0028] The walls 3, 3, 4 and 5 are generally planar surfaces, but may have various configurations. For example, the front wall 4 in the present embodiment defines a chevron shape. In the present embodiment, the rear wall 5 is a substantially planar surface which allows the receptacle to be positioned against a wall or the like. The receptacle 2 has a central axis CA extending from the base 6 to the open end 7. The receptacle 2 is typically positioned in use in a vertical position with the central axis CA extending vertically. In this typical arrangement, the open end 7 extends along a horizontal plane. Other configurations of the receptacle 2 and other mounting arrangements may also be utilized.

[0029] The cover 10 generally comprises a body portion 12 and a lid portion 50. The body portion 12 includes a covering surface 14 configured to substantially cover and thereby close the receptacle open end 7. The covering surface 14 generally has a configuration that complements the configuration of the receptacle rim 8. As such, in the present embodiment, the covering surface 14 has a front portion with a chevron shape and a rear portion that is shaped to correspond to the planar rear wall 5.

[0030] A flange 16 depends from at least a portion of the covering surface 14. The flange 16 is configured to fit about the receptacle open end rim 8. The flange 16 may be continuous about the perimeter of the receptacle rim 8 (as in the embodiment of cover 10 illustrated in FIGS. 1-7), or may be segmented and provided at various positions about the receptacle rim 8. The body portion 12 is preferably provided with means for securing the cover 10 to the receptacle 2. In the present embodiment, locking tabs 17 configured to engage the receptacle rim 8 are provided at various locations about the flange 16, as shown in FIG. 5. Alternatively, the body portion 12 may have a friction fit with respect to the receptacle 2, clips (not shown) may

extend between the body portion 12 and the receptacle 2, the receptacle rim 8 may be provided with projections which engage the flange 16, or the body portion 12 may be provided with projections which extend through bores provided in the receptacle rim 8. Other securing means may also be utilized. The body portion 12 may further include internal ribs 13 configured to engage the receptacle 2 to further support the cover 10 relative to the receptacle 2.

[0031] The body portion 12 has an access opening 20 through the covering surface 14. The access opening 20 is positioned within an inlet area that is defined by a rear lateral edge 19, a front lateral edge 21 and opposed side edges 23 and 25 extending between the rear and front edges 19, 21. A front wall 22 is provided along the front lateral edge 21 and opposed side walls 26, 28 extend along the side edges 23, 25, respectively. The lid portion 50 extends proximate to the rear edge 19 as will be described in greater detail hereinafter.

[0032] As shown in FIGS. 3 and 7, the side walls 26, 28 may extend beyond the access opening edges 23, 25 to the location of a hinge 54 of the lid portion 50. In use, the receptacle 2 is secured to a wall surface or the like with the lid portion 50 pivoted to a substantially vertical or upwardly-angled position in which the lid portion 50 rests against the wall surface. The lid portion 50 may have instructions inscribed on an internal surface that will be directed to a user when the lid portion 50 is in this use position. For example, the lid portion 50 optionally includes directions such as "DROP SHARP HORIZONTALLY IN OPENING," other information, or other indicia for communication to a user of the cover 10.

[0033] In this use position, the lid portion 50, the opening front wall 22 and the opening side walls 26, 28 effectively define a funnel into the access opening 20. Any sharp or other device positioned within this funnel area will thereby be directed to the access opening 20. Referring to FIG. 1, the covering surface 14 slopes downward from the opening front wall 21 and the opening side walls 26, 28 to the perimeter P. As such, the sloped covering surface 14 is not configured to accommodate a sharp or other device. This configuration discourages a user from intentionally or inadvertently leaving a sharp or the like on the covering surface 14 which may pose a danger to that user or a later user.

[0034] Referring to FIG. 3, a substantially fixed tortuous path extends from the inlet area defined by the rear lateral edge 19, the front lateral edge 21 and the opposed side edges 23 and 25 and through the access opening 20 to provide a tortuous entry passage into the receptacle cavity. The tortuous entry passage allows for the unrestricted passage of medical instruments and/or waste past stationary surfaces while making hand insertion into the receptacle difficult, if not impossible. In the present embodiment, the tortuous path is defined by a front slide 30 extending from the front lateral edge 21 and a rear slide 40 extending from the rear lateral edge 19. The front and rear slides 30, 40 are formed integrally with the covering surface 14. Preferred methods of manufacture are described in more detail hereinafter.

[0035] The front slide 30 includes a sloped front slide surface 32 terminating along a lateral edge 34. The front slide surface 32 extends laterally between the opposed side walls 26, 28 and has a generally planar configuration, although other configurations are possible. The rear slide 40 includes a sloped rear slide surface 42 terminating along a

lateral edge 44. The rear slide surface 42 has a curved surface that reduces in slope toward the lateral edge 44. Other configurations are also possible. The rear slide surface 42 extends laterally between rear slide surface edges 41 and 43 as shown in FIG. 2. Each side wall 26, 28 includes or extends to an extending wall portion 27, 29, respectively, extending from the side wall 26, 28 to the respective slide surface edge 41, 43. The extending wall portions 27, 29 extend between the rear edge 19 and the front slide surface lateral edge 34, but may extend farther.

[0036] The extending wall portions 27, 29 retain deposited materials within the lateral extents of the rear slide surface 42 and also provide support for the rear slide surface 42 of rear slide 40. A substantially rectangular lower opening is therefore defined by the lateral edge 44 of the rear slide surface 42 and the forward edges of the extending wall portions 27, 29. This lower opening is oriented in a plane that is substantially vertical or at an angle to a vertical plane, as will be described later in greater detail. Supporting ribs 46 or the like may be provided along a rear surface of the rear slide 40, on or opposite rear slide surface 42, at various locations between the side edges 41, 43 to provide additional support.

[0037] The perimeter edge of the access opening 20 is therefore defined by the rear lateral edge 19, the front lateral edge 34 and upper edges of the extending wall portions 27, 29. Thus, a substantially rectangular access opening 20 (in the embodiment illustrated in FIGS. 1-7) is oriented along a plane that is sloped toward the rear of the cover 10.

[0038] Medical waste introduced into the tortuous path through the inlet area of the cover 10 follows a circuitous path into the interior of the receptacle 2. More specifically, medical waste is deposited within the interior of the receptacle 2 after it passes into the inlet area defined by the rear lateral edge 19, front lateral edge 21 and opposed side edges 23 and 25; travels through the access opening 20 defined by the rear lateral edge 19, the front lateral edge 34 and upper edges of the extending wall portions 27, 29; and passes through the lower opening defined by the lateral edge 44 of the rear slide surface 42 and the forward edges of the extending wall portions 27, 29.

[0039] The front slide 30 and the rear slide 40 are configured such that the front slide surface 32 is horizontally axially spaced from the rear slide surface 42 in non-overlapping relation. More specifically, a plane S1 parallel to the central axis CA and extending through the front lateral edge 34 of the front slide surface 32 is horizontally axially spaced a distance d from a plane S3 parallel to the central axis CA and extending through the lateral edge 44 of the rear slide surface 42. The distance d is from 0 inches to approximately 1 inch, with a preferred range from greater than zero inches to about 7/8 inch, and a more preferred range from about 1/8 inch to about 5/8 inch, and a more preferred range from about 1/4 inch to about 1/2 inch. Additionally, a plane S2 extending through the front lateral edge 34 of the front slide surface 32 and the lateral edge 44 of the rear slide surface 42 (i.e., the plane of the lower opening defined by the lateral edge 44 of the rear slide surface 42 and the forward edges of the extending wall portions 27, 29) is at an angle α relative to the plane S1. The angle α is from 0 degrees to approximately 25 degrees, with a preferred range from greater than 0 degrees to about 20 degrees, and a more

preferred range from about 2 degrees to about 15 degrees, and a more preferred range from about 5 degrees to about 10 degrees. The distance d and the angle α are selected to provide a tortuous path entry passage having a desired waste clearance and a desired user inaccessibility.

[0040] The substantially fixed tortuous path allows a user to dispose of an item into the receptacle 2 by dropping the item into the funnel area leading to the access opening 20. Gravity causes the item to pass by the front and rear slides 30, 40 and into the receptacle 2. The user does not have to actuate the cover 10 to cause disposal or even contact the cover 10 in any manner during disposal. The disposed item passes freely into the receptacle 2, however, the tortuous path reduces or eliminates the possibility of an individual reaching into the receptacle 2.

[0041] While the present embodiment is described with a front slide 30 and a rear slide 40, both may not be necessary. For example, the front slide 30 may be eliminated while the rear slide surface 42 is extended axially in a forward direction. With the front slide 30 eliminated, the plane S1 would extend through the opening front edge 21. If so modified, the spatial relationship between the planes S1 and S3 and the angular relationship between planes S2 and S1 provided in the cover 10 would still be maintained to provide a desired tortuous path.

[0042] Additionally, while the present embodiment is described with the rear slide surface 42 having a larger axial length than the front slide surface 32, such configuration can be reversed. For example, the front slide surface 32 may be configured with a larger axial length and extending at a steeper angle such that the front lateral edge 34 of the front slide surface 32 is lower than the lateral edge 44 of the rear slide surface 42. Other configurations may also be utilized.

[0043] To close the access opening 20 once the receptacle is filled to a desired level, the cover 10 includes a lid portion 50 configured to cover and close the inlet area and access opening 20. In the present embodiment, the lid portion 50 is integrally hinged to the body portion 12 along a rear edge 15 of the outer perimeter P of the body portion 12. The outer perimeter P is defined by the outer extent of the covering surface 14 and the flange 16. The perimeter P may be defined by both the covering surface 14 and the flange 16 if, for example, the flange 16 extends radially outward of the covering surface 14 along a portion of the perimeter, but is inward of the covering surface 14 along other portions of the perimeter. At the locations where the flange 16 is outward, the flange 16 will define that portion of the perimeter P and at locations where the covering surface 14 is outward, the covering surface 14 will define that portion of the perimeter P. 15 The lid portion 50 includes a lid surface 52 configured to complement the shape of the inlet area and/or the access opening 20. In the present embodiment, the lid surface 52 has a substantially rectangular configuration, but other configurations are also possible. An integral hinge 54 (e.g., a living hinge) extends between the lid surface 52 and the rear perimeter edge 15 of the body portion 12. The hinge 54 of the present embodiment extends substantially along the entire length of the lid surface 52, however, the hinge 54 may be formed as one or more segments that extend less than the length of the lid surface 52. As illustrated in FIG. 5, the hinge 54 is optionally formed by providing a section of reduced material thickness. Such reduced thickness pro-

vides the hinge 54 with greater flexibility than the neighboring lid portion 50 or cover portion 10. The hinge 54 therefore has sufficient flexibility to allow the lid portion 50 to be pivoted from the open position shown in FIG. 3 to the closed position shown in FIG. 5, to be described in greater detail later.

[0044] To lock the lid portion 50 in the closed position, the lid portion 50 includes one or more locking tabs 56 extending from the lid surface 52. A locking bore 36 corresponding to each locking tab 56 is provided adjacent the opening front edge 21 (FIG. 4). In the present embodiment, the locking bores 36 are provided through the front slide surface 32 and each locking bore 36 defines a locking shoulder 38 below the front wall 22, as shown in FIG. 4. To close the inlet area and access opening 20, the lid surface 52 is pivoted about the hinge 54 until each locking tab 56 engages a respective locking shoulder 38, as shown in FIG. 7. The engagement of the locking tabs 56 with the locking shoulders 38 preferably permanently locks the lid portion 50 in the closed position, prevents unauthorized opening of the lid portion 50, and / or inhibits unintended opening of the lid portion 50. Each locking tab 56 preferably has a support rib 55 having a width equal to the width of the locking bore 36 to prevent prying of the locking tabs 56 from the locking bores 36 (see FIGS. 1-3 and 7).

[0045] Having generally described the components of the cover 10 and the operation thereof, a method of manufacturing the cover 10 that is a first embodiment of the inventive method will be described with reference to FIGS. 3, 5 and 8-11. The first embodiment of the inventive method utilizes a mold assembly 300 including first and second mold portions 302, 304 that are linearly moveable relative to each other in a direction parallel to the mold axis MA. The mold assembly 300 is configured for use in an injection molding process in which plastic material is injected into a cavity defined by mold portions 302, 304 to form the cover 10. In use, the mold portions 302, 304 are moved with respect to one another along the mold axis MA between an open position in which the mold portions are spaced from one another (e.g., for removal for a completed cover 10) and a closed position in which the mold portions contact one another to define the cavity.

[0046] The mold portions 302 and 304 have a control assembly for controlling the alignment and movement of the mold portions 302 and 304 relative to one another. For example, one mold portion 304 may be provided with posts 308 that are received in corresponding bores 306 in the other mold portion 302 to align and control linear motion of the mold portions 302 and 304. Other assemblies may also be utilized.

[0047] The mold assembly 300 has one or more injection ports 330 or the like configured to dispose moldable material in cavity portions 318, 320, 322, 324, 326 formed between the mold portions 302 and 304. The mold portions 302 and 304 and cavity portions 318, 320, 322, 324, 326 are configured such that all of the components of the cover 10 may be formed as a unitary structure while allowing simple linear separation of the mold portions 302 and 304 in a direction parallel to the mold axis MA, as indicated by arrows A in FIG. 11. In other words, all of the surfaces of the mold cavity forming cover 10 are provided, according to one exemplary aspect of this invention, by two mold portions

movable along a common axis. Thus, simplified and cost effective mold tooling and processes are optionally employed, thereby reducing the effort and cost associated with the manufacture of the cover 10. Known mold assemblies, in contradistinction, have required additional mold components, for example, cross sliding components to make complex, unitary structures.

[0048] Referring to FIGS. 8-11, both mold portions 302, 304 include male and female mold surfaces 310, 311, 312, 313, 315, 317, 319, 321, 323, 325, 327, 329, 331, 333, 335 configured and positioned to define the cavity portions 318, 320, 322, 324, 326 when the mold portions 302 and 304 are positioned relative to one another. For example, a cavity portion 324 configured to form the rear slide 40 of the cover 10 is defined by mold surfaces 311, 312 and 313 while cavity portion 322 configured to form the front slide 30 of the cover 10 is defined by mold surfaces 310, 315 and 317.

[0049] As shown in FIGS. 10 and 11, the mold surfaces 310 and 312 mate along the plane S2, which is the plane that extends through the front lateral edge 34 of the front slide surface 32 and the lateral edge 44 of the rear slide surface 42 of the cover 10 (i.e., the plane of the lower opening defined by the lateral edge 44 of the rear slide surface 42 and the forward edges of the extending wall portions 27, 29). The plane S1 (the plane parallel to the central axis CA and extending through the front lateral edge 34 of the front slide surface 32 of the cover 10) is configured to be substantially parallel to the mold axis MA. The angle α of the mating plane S2 relative to the plane S1 allows the mold surfaces 310 and 312 to adequately seal between the two cavities 322 and 324. Additionally, the angle α of the mating plane S2 allows the two mold portions 302 and 304 to be moved apart in a direction parallel to the mold axis MA, as indicated by arrows A, without interfering with either of the molded slide surfaces 32 or 42 that are formed in the cavity portions 322 and 324, respectively. As indicated previously, the angle α according to one embodiment is between 0 degrees and approximately 20 degrees, with a preferred range from about 2 degrees to about 15 degrees, and a more preferred range from about 5 degrees to about 10 degrees.

[0050] Additional mold surfaces 325 may be provided adjacent the surface 313 to assist in forming the locking tabs 17 along the rear portion of the rim 16. As illustrated in FIG. 5, the mold surfaces 325 leave apertures 18 through the covering surface 14; however, the apertures 18 are sufficiently small that they do not allow access within the cover 10 and are also covered by the lid portion 50 when the lid portion 50 is closed as illustrated in FIG. 7. Similarly, mold surfaces 335 may be provided adjacent mold surface 317 to define the locking bores 36 illustrated in FIG. 4. The mold surfaces 335 cooperate with the mold surface 319 to define the locking shoulders 38.

[0051] Mold surface 319 also cooperates with mold surfaces 321 and 323 to define cavity portion 320 configured to form the body portion 12. Mold surfaces 327 and 329 cooperate to define cavity portion 326 configured to form the lid surface 52. Mold surfaces 327 and 329 further cooperate with mold surface 325 to define cavity portion 318 configured to form the hinge 54 between the lid surface 52 and the body portion 12. The mold surface 329 is preferably configured to form the flange 16 with an inward draft angle, as indicated in FIG. 5 by the angle θ between planes E and F.

The inward draft angle assists in defining the hinge cavity portion **318** and the separation of the mold portions **302** and **304**. Mold surfaces **327**, **331** and **333** cooperate to define a cavity portions configured to form the locking tabs **56**.

[0052] As illustrated in **FIG. 11**, the mold surfaces are preferably configured such that the cavity portion **326** that forms the lid portion **50** is at an approximate right angle with respect to the mold axis MA to facilitate separation of the mold portions **302** and **304** in the direction of arrows A. However, other angles may also be utilized.

[0053] To form the integral cover **10**, moldable material is supplied to the cavity portions, for example, through injection ports **330**. The mold portions **302** are thereafter separated in the direction of arrows A in **FIG. 11** and the integral cover **10** is removed. The cover **10** is substantially ready for use and does not require any substantial secondary operations to assemble the cover **10**.

[0054] Referring to **FIGS. 12-14**, a cover **110** that is alternate embodiment of the present invention will be described. The cover **110** is similar to cover **10** in that it has a one-piece construction that is capable of being formed using a cost effective molding process. As will be describe in detail below, however, the cover **110** differs from cover **10** in the manner in which the lid is coupled to the body portion and in other ways.

[0055] The cover **110** includes a body portion **112** and a lid portion **150**. The body portion **112** includes a covering surface **114** configured to substantially cover and thereby close a receptacle open end **7**. The covering surface **114** generally has a configuration that complements the configuration of the receptacle rim **8**. In the present embodiment, the covering surface **114** has a chevron shape in both the front and rear portions.

[0056] A flange **116** depends from at least a portion of the covering surface **114**. The body portion **112** of cover **110** is preferably provided with means for securing the cover **110** to a receptacle **2**. In the present embodiment, locking tabs **117** configured to engage the receptacle rim **8** are provided at various locations about the flange **116**, as shown in **FIG. 14**. Other securing means may also be utilized.

[0057] The body portion **112** has an access opening **120** through the covering surface **114**. The access opening **120** is defined by a rear lateral edge **119**, a front lateral edge **121** and opposed side edges **123** and **125** extending between the rear and front edges **119**, **121**. Referring to **FIG. 14**, a substantially fixed tortuous path extends from the access opening **120** to provide a tortuous entry passage into the receptacle cavity from the access opening **120** which allows for the unrestricted passage of medical instruments and/or waste past stationary surfaces while making hand insertion into the receptacle difficult, if not impossible. In the present embodiment, the tortuous path is defined by a rear slide **130** extending from the opening rear lateral edge **119** and a front slide **140** extending from the opening front lateral edge **121**. The rear and front slides **130**, **140** are formed integrally with the covering surface **114**.

[0058] The rear slide **130** includes a sloped rear slide surface **132** terminating along a lateral edge **134**. The rear slide surface **132** extends laterally between opposed side walls **127** and has a generally planar configuration, although other configurations are possible. The front slide **140**

includes a stepped front slide surface terminating along a lateral edge **144**. The stepped slide surface includes a first sloped portion **142** followed by a substantially horizontal step **146** followed by a second sloped portion **148** that terminates at the lateral edge **144**. The first and second slide surfaces **142** and **148** are substantially planar surfaces, but other configurations are also possible.

[0059] The perimeter edge of the access opening **120** is therefore defined by the rear lateral edge **119**, the front lateral edge **121** and upper edges of the side walls **127**. Thus, a substantially rectangular access opening **120** (in the embodiment illustrated in **FIGS. 12-14**) is oriented along a plane that is substantially horizontal but that may be sloped such as toward the rear of the cover **110**.

[0060] The horizontal step **146** of the front slide **140** includes a plurality of locking bores **136** configured to receive locking tabs **156** on the lid portion **150** as will be described hereinafter. The front slide extends laterally between side walls **127**. The rear and front slides **130**, **140** and the side walls **127** effectively define a funnel-shaped path into the receptacle. A substantially rectangular lower opening is therefore defined by the lateral edge **144** of the front slide surface **142** and the lower edges of the side walls **127**. This lower opening is oriented in a plane that is substantially vertical or at an angle to a vertical plane, as will be described later in greater detail.

[0061] Medical waste introduced into the tortuous path through the inlet area of the cover **110** follows a circuitous path into the interior of the receptacle **2**. More specifically, medical waste is deposited within the interior of the receptacle **2** after it passes into the inlet area; travels through the access opening **120** defined by the rear lateral edge **119**, the front lateral edge **121** and upper edges of the side walls **127**; and passes through the lower opening defined by the lateral edge **144** of the front slide surface **142** and the lower edges of the side walls **127**.

[0062] The rear slide **130** and the front slide **140** are configured such that the rear slide surface **132** is axially spaced from the front second slide surface **148** in non-overlapping relation. A plane S1 parallel to the central axis CA and extending through the rear lateral edge **134** is axially spaced a distance d from a plane **53** parallel to the central axis CA and extending through the front lateral edge **144**. The distance d is from 0 inches to approximately 1 inch, with a preferred range from greater than zero inches to about $7/8$ inch, and a more preferred range from about $1/8$ inch to about $5/8$ inch, and a more preferred range from about $1/4$ inch to about $1/2$ inch. Additionally, a plane S2 extending through the rear lateral edge **134** and the front lateral edge **144** is at an angle α relative to the plane S1. The angle α is from 0 degrees to approximately 25 degrees, with a preferred range from greater than 0 degrees to about 20 degrees, and a more preferred range from about 2 degrees to about 15 degrees, and a more preferred range from about 5 degrees to about 10 degrees. The distance d and the angle α are selected to provide a tortuous path entry passage having a desired waste clearance and a desired user inaccessibility.

[0063] To close the access opening **120** once the receptacle is filled to a desired level, the cover **110** includes a lid portion **150** configured to cover and close the access opening **120**. In the present embodiment, the lid portion **150** is integrally hinged to the body portion **112** along the outer

perimeter P of the body portion 112 via straps 153. The lid portion 150 includes a lid surface 152 configured to complement the shape of the access opening 120. In the present embodiment, the lid surface 152 has a rectangular configuration, but other configurations are also possible.

[0064] Each strap 153 extends between the lid surface 152 and a respective integral hinge 154 extending along the perimeter P of the body portion 112. To lock the lid portion 150 in the closed position, the lid portion 150 includes one or more locking tabs 156 extending from the lid surface 152. To close the access opening 120, the lid surface 152 is pivoted about the hinges 154 until each locking tab 156 engages in a respective locking bore 136. As illustrated in phantom in FIG. 13, the locking bores 136' may alternatively be provided along the covering surface 114.

[0065] The cover 110 is configured such that it can be manufactured utilizing the method described above with respect to cover 10. The mold surfaces will be arranged to provide cavity portions corresponding to the various components of cover 110. Again, the components are configured such that the mold portions may be linearly separated to remove the integrally formed cover 110.

[0066] Referring to FIGS. 15-17, a cover 210 that is alternate embodiment of the present invention will be described. The cover 210 is similar to cover 10 and cover 110 in that it has a one-piece construction that is capable of being formed using a cost effective molding process. As will be described in detail below, however, the cover 210 differs from cover 10 and cover 110 in the manner in which the lid is coupled to the body portion and in other ways.

[0067] The cover 210 includes a body portion 212 and a lid portion 250. The body portion 212 includes a covering surface 214 configured to substantially cover and thereby close a receptacle open end 7. The covering surface 214 has a substantially domed configuration, thereby providing a more pronounced profile as compared to that of covers 10 and 110. Such a profile is optionally provided in order to maximize the capacity of the receptacle 2, to provide steeper slopes at the front and side portions of the cover, and/or to permit a deeper extension of the surfaces defining the covers tortuous path.

[0068] The covering surface 214 generally has a configuration that complements the configuration of the receptacle rim 8. In the present embodiment, the covering surface 214 has a chevron shape in both the front and rear portions. The covering surface 214 of the present embodiment has a relatively steep slope such that the body portion 212 is deeper than that of the previous embodiments, as mentioned previously.

[0069] A flange 216 depends from at least a portion of the covering surface 214. The body portion 212 is preferably provided with means for securing the cover 210 to a receptacle 2, for example, locking tabs or the like configured to engage the receptacle rim 8. Other securing means may also be utilized.

[0070] The body portion 212 has an access opening 220 through the covering surface 214. The access opening 220 is defined by a rear lateral edge 219, a front lateral edge 221 and opposed side edges 223 and 225 extending between the rear and front edges 219, 221. A front wall 222 is provided along the opening front lateral edge 221.

[0071] Referring to FIG. 15, a substantially fixed tortuous path extends from the access opening 220 to provide a tortuous entry passage into the receptacle cavity from the access opening 220 which allows for the unrestricted passage of medical instruments and/or waste past stationary surfaces while making hand insertion into the receptacle difficult, if not impossible. In the present embodiment, the tortuous path is defined by a rear slide 230 extending from the opening rear lateral edge 219 and a front slide 240 extending from the opening front lateral edge 221. The rear and front slides 230, 240 are formed integrally with the covering surface 214.

[0072] The rear slide 230 includes a sloped rear slide surface 232 terminating along a lateral edge 234. The front slide 240 includes a front slide surface 242 terminating along a lateral edge 244. The front slide surface 242 depends a distance Y from the covering surface 214. The distance Y is preferably less than the depth D of the body portion 212 in order to maintain the slide surface 242 above the interior of the receptacle 2. The rear and front slide surfaces 232 and 242 are substantially planar surfaces, but other configurations are also possible.

[0073] The rear slide 230 and the front slide 240 are configured such that the rear slide surface 232 is axially spaced from the front slide surface 242 in non-overlapping relation. A plane S1 parallel to the central axis CA and extending through the rear lateral edge 234 is axially spaced a distance d from a plane S3 parallel to the central axis CA and extending through the front lateral edge 244. The distance d is from 0 inches to approximately 1 inch, with a preferred range from greater than zero inches to about $7/8$ inch, and a more preferred range from about $1/8$ inch to about $5/8$ inch, and a more preferred range from about $1/4$ inch to about $1/2$ inch. Additionally, a plane S2 extending through the rear lateral edge 234 and the front lateral edge 244 is at an angle α relative to the plane S1. The angle α is from 0 degrees to approximately 25 degrees, with a preferred range from greater than 0 degrees to about 20 degrees, and a more preferred range from about 2 degrees to about 15 degrees, and a more preferred range from about 5 degrees to about 10 degrees. The distance d and the angle α are selected to provide a tortuous path entry passage having a desired waste clearance and a desired user inaccessibility.

[0074] The perimeter edge of the access opening 220 is therefore defined by the rear lateral edge 219, the front lateral edge 221 and the upper edge portions of the opposed side edges 223 and 225. Thus, a substantially rectangular access opening 220 (in the embodiment illustrated in FIGS. 15-17) is oriented along a plane that is substantially horizontal but that may be sloped such as toward the rear of the cover 210. A substantially rectangular lower opening is defined by the lateral edge 244 of the front slide surface 242 and the lower edges portions of the opposed side edges 223 and 225. This lower opening is oriented in a plane that is substantially vertical or at an angle to a vertical plane, as will be described later in greater detail.

[0075] Medical waste introduced into the tortuous path through the inlet area of the cover 210 follows a circuitous path into the interior of the receptacle 2. More specifically, medical waste is deposited within the interior of the receptacle 2 after it passes into the inlet area; travels through the access opening 220 defined by the rear lateral edge 219, the

front lateral edge 221 and upper edge portions of the opposed side edges 223 and 225; and passes through the lower opening defined by the lateral edge 244 of the front slide surface 242 and the lower edges portions of the opposed side edges 223 and 225.

[0076] To close the access opening 220 once the receptacle is filled to a desired level, the cover 210 includes a lid portion 250 configured to cover and close the access opening 220. In the present embodiment, the lid portion 250 is integrally hinged to the body portion 212 along the outer perimeter P of the body portion 212 via straps 253. The lid portion 250 includes a lid surface 252 configured to complement the shape of the access opening 220. Each strap 253 extends between the lid surface 252 and a respective integral hinge 254 extending along the perimeter P of the body portion 212.

[0077] Due to the deeper nature of the body portion 212 (as compared to body portions 12 and 112 of other cover embodiments), the straps 253 have an extended length with an intermediate locking tab 255 and a secondary hinge 257. To move the lid surface 252 to an operable position, the straps 253 are pivoted about the hinges 254 and the intermediate locking tabs 255 are inserted into intermediate locking bores 235 in the covering surface 214. The straps 253 have a length L that is approximately equal to the depth D of the body portion 212 such that when the locking tabs 255 are locked in the locking bores 235, the hinges 257 are adjacent the top of the body portion 212. As such, to lock the lid portion 250 in the closed position, the lid surface 252 is pivoted about the hinges 257 until each locking tab 256 engages in a respective locking bore 236.

[0078] The cover 210 is configured such that it can be manufactured utilizing the method described above with respect to cover 10. The mold surfaces will be arranged to provide cavity portions corresponding to the various components of cover 210. FIG. 15 illustrates bores 218 that may be provided to mold internal components, for example, internal locking tabs (not shown). Again, the components are configured such that the mold portions may be linearly separated to remove the integrally formed cover 210.

[0079] Although the invention is illustrated and described herein with reference to specific embodiments, the invention is not intended to be limited to the details shown. Rather, various modifications may be made in the details within the scope and range of equivalents of the claims and without departing from the invention.

What is claimed:

1. A cover for a medical waste disposal receptacle, said receptacle defining a receptacle open end and a receptacle body extending from the open end, the receptacle body having an axis extending in a given direction, said cover comprising:

a body portion configured to substantially close said receptacle open end, said body portion defining a tortuous path access opening having opposed, axially spaced, first and second lateral edges, the body portion including at least a first integral sloped slide surface that defines the first lateral edge; and

wherein said first and second lateral edges are configured such that a plane extending through said first and second lateral edges is at an angle of from 0 degrees to

about 25 degrees relative to a plane parallel to the given direction and extending through said second lateral edge.

2. The cover according to claim 1 wherein the angle is from greater than 0 degrees to about 20 degrees.

3. The cover according to claim 1 wherein the angle is from about 2 degrees to about 15 degrees.

4. The cover according to claim 1 wherein the angle is from about 5 degrees to about 10 degrees.

5. The cover according to claim 1 wherein the given direction extends in a vertical plane.

6. The cover according to claim 1 wherein the body portion includes a second integral sloped slide surface that defines the second lateral edge.

7. The cover according to claim 1 wherein the body portion has a given perimeter and a lid portion configured to selectively close said access opening is hinged to the body portion by an integrally formed hinge extending along a portion of said given perimeter.

8. A method of forming a cover for a medical waste disposal receptacle having an open end, said method comprising the steps of:

disposing of moldable material within a mold assembly that is linearly separable in a given direction, the mold assembly having a cavity portion configured to form a cover body portion defining an access opening having opposed, axially spaced first and second lateral edges, the body portion including at least a first integral sloped slide surface that defines the first lateral edge, the cavity portion configured such that a plane extending through said first and second lateral edges is at an angle from 0 degrees to about 25 degrees relative to a plane parallel to the given direction and extending through said second lateral edge;

separating said mold assembly in the given direction; and

removing from the mold assembly a formed cover with an integrally formed tortuous path access opening.

9. The method according to claim 8 wherein the angle is from greater than 0 degrees to about 20 degrees.

10. The method according to claim 8 wherein the angle is from about 2 degrees to about 15 degrees.

11. The method according to claim 8 wherein the angle is from about 5 degrees to about 10 degrees.

12. The method according to claim 8 wherein the cavity portion is further configured such that the body portion includes a second integral sloped slide surface that defines the second lateral edge.

13. A cover for a medical waste disposal receptacle, said receptacle defining a receptacle open end, said cover comprising:

a body portion including a covering surface configured to substantially close said receptacle open end except for an access opening therethrough, said body portion further including integrally formed, fixed first and second sloped slide surfaces depending from the covering surface adjacent the access opening,

wherein the first and second slide surfaces are axially spaced in non-overlapping relation to define a tortuous path extending from the access opening.

14. The cover according to claim 13 wherein the first sloped slide surface terminates at a first lateral edge and the

second sloped slide surface terminates at a second lateral edge axially spaced from the first lateral edge by a distance d.

15. The cover according to claim 14 wherein the first lateral edge is spaced a greater distance from the covering surface than the second lateral edge.

16. The cover according to claim 14 wherein the second lateral edge is spaced a greater distance from the covering surface than the first lateral edge.

17. The cover according to claim 14 wherein the distance d is from 0 inches to approximately 1 inch.

18. The cover according to claim 14 wherein the distance d is between greater than 0 inches and about $7/8$ inch.

19. The cover according to claim 14 wherein the distance d is between about $1/8$ inch and about $5/8$ inch.

20. The cover according to claim 14 wherein the distance d is between about $1/4$ inch and about $1/2$ inch.

21. The cover according to claim 13 wherein the body portion has a front edge and a rear edge and the first sloped slide surface is closer to the body portion rear edge and the second sloped slide surface is closer to the body portion front edge.

22. The cover according to claim 21 wherein the access opening defines a planar opening that is sloped toward the body portion rear edge.

23. The cover according to claim 13 wherein the first sloped slide surface has opposed first and second slide surface side edges and wherein a first support wall extends between the covering surface and the first slide surface side edge and a second support wall extends between the covering surface and the second slide surface side edge.

24. The cover according to claim 23 wherein the first sloped slide surface terminates at a first lateral edge and the second sloped slide surface terminates at a second lateral edge axially spaced from the first lateral edge, and wherein the first and second lateral edges and first and second support walls define a substantially rectangular lower opening spaced from and at an angle relative to the access opening.

25. The cover according to claim 13 wherein the access opening is defined by a front opening edge, a rear opening edge and opposed side edges extending between the front and rear opening edges.

26. The cover according to claim 25 wherein a wall portion extends upward from the covering surface proximal the front opening edge and both side opening edges.

27. The cover according to claim 26 wherein a lid portion is hingedly connected to the body portion proximate the rear opening edge and wherein the wall portion and the lid portion define a funnel toward the access opening when the lid portion is in an operable position.

28. The cover according to claim 26 wherein the covering surface has an outer perimeter and at least a portion of the covering surface is downwardly sloped from the wall portion to the outer perimeter.

29. A method of forming a lid assembly for a medical waste disposal receptacle having an open end, said method comprising the steps of:

disposing of moldable material within a linearly separable mold assembly having a first cavity portion configured to form a covering surface configured to substantially close said receptacle open end, a second cavity portion in fluid communication with the first cavity portion and configured to form a first sloped slide surface extending from the covering surface, and a third cavity portion in

fluid communication with the first cavity portion and configured to form a second sloped slide surface extending from the covering surface, the second and third cavity portions configured such that the first and second slide surfaces are axially spaced in non-overlapping relation to one another;

separating the mold assembly in a linear direction; and removing from the mold assembly a formed cover with the first and second slide surfaces defining a tortuous path access opening.

30. The method of claim 29 wherein the step of disposing of moldable material includes injecting a moldable material into the cavity portions.

31. The method of claim 30 wherein the moldable material is a plastic.

32. A cover for a medical waste disposal receptacle, said receptacle defining a receptacle open end, said cover comprising:

a body portion including a covering surface configured to substantially close said receptacle open end, said body portion having a given perimeter and having an access opening through the covering surface, the body portion further including at least a first fixed sloped surface integrally depending from the covering surface adjacent the access opening;

a lid portion configured to selectively close said access opening; and

an integrally formed hinge extending along a portion of said given perimeter and hingedly interconnecting said lid portion to said body portion.

33. The cover according to claim 32 wherein a flange depends from at least a portion of the cover surface.

34. The cover according to claim 33 wherein the flange is configured to engage the receptacle and thereby secure the cover to the receptacle.

35. The cover according to claim 34 wherein the flange includes at least two inwardly extending tabs configured to engage the receptacle.

36. The cover according to claim 33 wherein the perimeter is defined by an outer extent of the covering surface, by a portion of the flange or by a combination of the outer extent of the covering surface and a portion of the flange.

37. The cover according to claim 32 wherein the lid portion includes a lid surface having a lateral edge having a given length and the hinge extends along substantially the length of the lid surface lateral edge.

38. The cover according to claim 32 wherein at least one strap extends between the lid portion and the hinge.

39. The cover according to claim 38 wherein the first fixed sloped surface depends from the covering surface a distance Y and the first body portion has a depth D wherein the depth D is greater than the distance Y.

40. The cover according to claim 39 wherein the lid portion includes a lid surface and a second hinge extends between the strap and the lid surface and wherein the second hinge is spaced from the first hinge by a distance approximately equal to the depth D.

41. The cover according to claim 40 wherein the strap includes a locking tab positioned between the first and second hinges and the locking tab is configured to lock with respect to the body portion to maintain the lid surface in an operable position.

42. The cover according to claim 32 wherein the lid portion includes at least one locking tab configured to engage the body portion and lock the lid portion relative to the body portion when the lid portion is positioned to close the access opening.

43. The cover according to claim 32 wherein the covering surface has a front edge and a rear edge.

44. The cover according to claim 43 wherein the rear edge has a substantially planar configuration.

45. The cover according to claim 43 wherein the front edge has a chevron shape.

46. The cover according to claim 43 wherein the access opening is positioned closer to the rear edge than to the front edge.

47. A method of forming a cover for a medical waste disposal receptacle having an open end, said method comprising the steps of:

disposing of moldable material within a linearly separable mold assembly having a first cavity portion configured to form a body portion having a covering surface configured to substantially close the receptacle open end except for an access opening therethrough, a sec-

ond cavity portion in fluid communication with the first cavity portion adjacent the access opening and configured to form a sloped slide surface, a third cavity portion configured to form a lid portion of the cover, and a fourth cavity portion extending between and in fluid communication with the first and third cavity portions and configured to form a hinge; and

removing a formed cover from the mold assembly with the lid portion integrally hinged to the body portion and a fixed sloped slide surface depending from the covering surface.

48. The method according to claim 47 wherein the first cavity portion is further configured to form a flange depending from a portion of the covering surface and wherein at least a portion of the flange is angled inward toward the access opening and away from the hinge.

49. The method according to claim 47 wherein the fourth cavity portion is further configured to define a strap extending between the hinge and the lid portion.

* * * * *