



## INTERNATIONAL APPLICATION PUBLISHED UNDER THE PATENT COOPERATION TREATY (PCT)

<p>(51) International Patent Classification<sup>6</sup> : <b>D06F 37/22, F16F 7/08</b></p>	<p><b>A3</b></p>	<p>(11) International Publication Number: <b>WO 99/01677</b></p> <p>(43) International Publication Date: 14 January 1999 (14.01.99)</p>
<p>(21) International Application Number: PCT/US98/13196</p> <p>(22) International Filing Date: 25 June 1998 (25.06.98)</p> <p>(30) Priority Data: 60/051,636 3 July 1997 (03.07.97) US 09/028,780 24 February 1998 (24.02.98) US</p> <p>(71) Applicant: ROCKSHOX, INC. [US/US]; 401 Charcot Avenue, San Jose, CA 95131 (US).</p> <p>(72) Inventor: BALDOMERO, Ricardo, R.; 10715 Vera Avenue, Felton, CA 95018 (US).</p> <p>(74) Agents: HANSEN, David, W. et al.; Skadden, Arps, Slate, Meagher &amp; Flom LLP, 919 Third Avenue, New York, NY 10022-3897 (US).</p>	<p>(81) Designated States: AL, AM, AT, AU, AZ, BA, BB, BG, BR, BY, CA, CH, CN, CU, CZ, DE, DK, EE, ES, FI, GB, GE, GH, GM, GW, HU, ID, IL, IS, JP, KE, KG, KP, KR, KZ, LC, LK, LR, LS, LT, LU, LV, MD, MG, MK, MN, MW, MX, NO, NZ, PL, PT, RO, RU, SD, SE, SG, SI, SK, SL, TJ, TM, TR, TT, UA, UG, UZ, VN, YU, ZW, ARIPO patent (GH, GM, KE, LS, MW, SD, SZ, UG, ZW), Eurasian patent (AM, AZ, BY, KG, KZ, MD, RU, TJ, TM), European patent (AT, BE, CH, CY, DE, DK, ES, FI, FR, GB, GR, IE, IT, LU, MC, NL, PT, SE), OAPI patent (BF, BJ, CF, CG, CI, CM, GA, GN, ML, MR, NE, SN, TD, TG).</p> <p><b>Published</b> <i>With international search report.</i></p> <p>(88) Date of publication of the international search report: 17 June 1999 (17.06.99)</p>	

(54) Title: PISTON ROD AND PISTON ASSEMBLY

(57) Abstract

A lightweight low cost damping assembly having a piston rod (10) on which a piston (40) is formed such that fastener elements are not needed to secure the piston onto the piston rod. Preferably, the piston rod is formed by chrome plating the exterior of a tubular steel rod except at a piston attachment portion. The piston attachment portion is specially shaped such that the piston may be formed thereon and coupled thereto by the inter-engaging of the piston with the shape of the piston attachment portion. Most preferably, the piston attachment portion is in the form of shallow grooves, knurls (44) or dimples in the exterior of the piston rod and the piston is injection molded thereon. The material of the piston molds itself into the shape of the piston attachment portion, thereby resulting in a secure coupling between the piston and the piston rod.

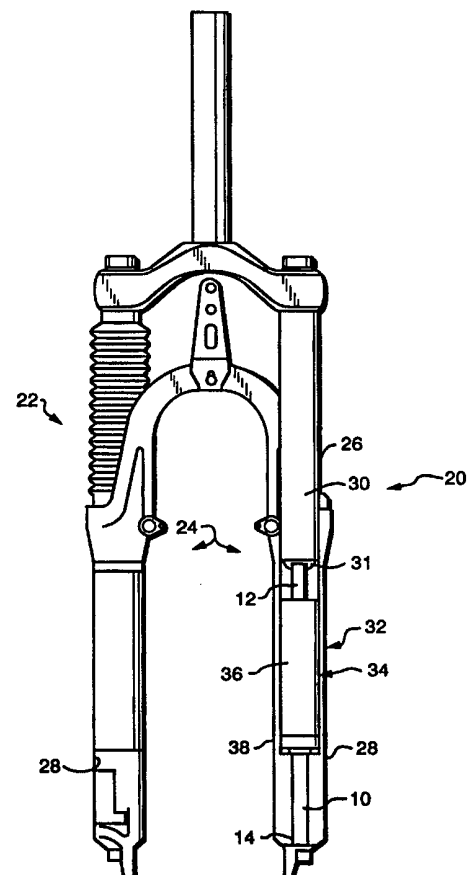

**FOR THE PURPOSES OF INFORMATION ONLY**

Codes used to identify States party to the PCT on the front pages of pamphlets publishing international applications under the PCT.

AL	Albania	ES	Spain	LS	Lesotho	SI	Slovenia
AM	Armenia	FI	Finland	LT	Lithuania	SK	Slovakia
AT	Austria	FR	France	LU	Luxembourg	SN	Senegal
AU	Australia	GA	Gabon	LV	Latvia	SZ	Swaziland
AZ	Azerbaijan	GB	United Kingdom	MC	Monaco	TD	Chad
BA	Bosnia and Herzegovina	GE	Georgia	MD	Republic of Moldova	TG	Togo
BB	Barbados	GH	Ghana	MG	Madagascar	TJ	Tajikistan
BE	Belgium	GN	Guinea	MK	The former Yugoslav Republic of Macedonia	TM	Turkmenistan
BF	Burkina Faso	GR	Greece			TR	Turkey
BG	Bulgaria	HU	Hungary	ML	Mali	TT	Trinidad and Tobago
BJ	Benin	IE	Ireland	MN	Mongolia	UA	Ukraine
BR	Brazil	IL	Israel	MR	Mauritania	UG	Uganda
BY	Belarus	IS	Iceland	MW	Malawi	US	United States of America
CA	Canada	IT	Italy	MX	Mexico	UZ	Uzbekistan
CF	Central African Republic	JP	Japan	NE	Niger	VN	Viet Nam
CG	Congo	KE	Kenya	NL	Netherlands	YU	Yugoslavia
CH	Switzerland	KG	Kyrgyzstan	NO	Norway	ZW	Zimbabwe
CI	Côte d'Ivoire	KP	Democratic People's Republic of Korea	NZ	New Zealand		
CM	Cameroon			PL	Poland		
CN	China	KR	Republic of Korea	PT	Portugal		
CU	Cuba	KZ	Kazakstan	RO	Romania		
CZ	Czech Republic	LC	Saint Lucia	RU	Russian Federation		
DE	Germany	LI	Liechtenstein	SD	Sudan		
DK	Denmark	LK	Sri Lanka	SE	Sweden		
EE	Estonia	LR	Liberia	SG	Singapore		

INTERNATIONAL SEARCH REPORT

International application No.  
PCT/US98/13196

A. CLASSIFICATION OF SUBJECT MATTER

IPC(6) :D06F 37/22; F16F 7/08

US CL :188/129;276/202,203

According to International Patent Classification (IPC) or to both national classification and IPC

B. FIELDS SEARCHED

Minimum documentation searched (classification system followed by classification symbols)

U.S. : 188/129,322,15  
267/202,203,206,207

Documentation searched other than minimum documentation to the extent that such documents are included in the fields searched

Electronic data base consulted during the international search (name of data base and, where practicable, search terms used)

C. DOCUMENTS CONSIDERED TO BE RELEVANT

Category*	Citation of document, with indication, where appropriate, of the relevant passages	Relevant to claim No.
Y	US 5,549,182 A (EHRNSBERGER et al.) 27 August 1996 (27.08.96) , see Fig. 3.	1-21
Y	US 5,456,480 A (TURNER et al.) 10 October 1995 (10.10.95), see Fig. 3.	1-21
A	US 4,099,602 A (KOURBETSOS) 11 July 1978 (11.07.78).	
A	US 4,877,114 A (TAYLOR) 31 October 1989 (31.10.89).	
A	US 5,275,264 A (ISELLA) 04 January 1994 (04.01.94).	

Further documents are listed in the continuation of Box C.

See patent family annex.

\* Special categories of cited documents:

\*A\* document defining the general state of the art which is not considered to be of particular relevance

\*E\* earlier document published on or after the international filing date

\*L\* document which may throw doubts on priority claim(s) or which is cited to establish the publication date of another citation or other special reason (as specified)

\*O\* document referring to an oral disclosure, use, exhibition or other means

\*P\* document published prior to the international filing date but later than the priority date claimed

\*T\* later document published after the international filing date or priority date and not in conflict with the application but cited to understand the principle or theory underlying the invention

\*X\* document of particular relevance; the claimed invention cannot be considered novel or cannot be considered to involve an inventive step when the document is taken alone

\*Y\* document of particular relevance; the claimed invention cannot be considered to involve an inventive step when the document is combined with one or more other such documents, such combination being obvious to a person skilled in the art

\* & \* document member of the same patent family

Date of the actual completion of the international search

25 FEBRUARY 1999

Date of mailing of the international search report

08 APR 1999

Name and mailing address of the ISA/US  
Commissioner of Patents and Trademarks  
Box PCT  
Washington, D.C. 20231

Facsimile No. (703) 305-3230

Authorized officer

MATTHEW C. GRAHAM *Diana Smith Jr.*

Telephone No. (703) 308-1113