

Sept. 7, 1965

E. CAPUCIO

3,204,852

FLIP-OPEN CONTAINER

Filed April 10, 1964

2 Sheets-Sheet 1

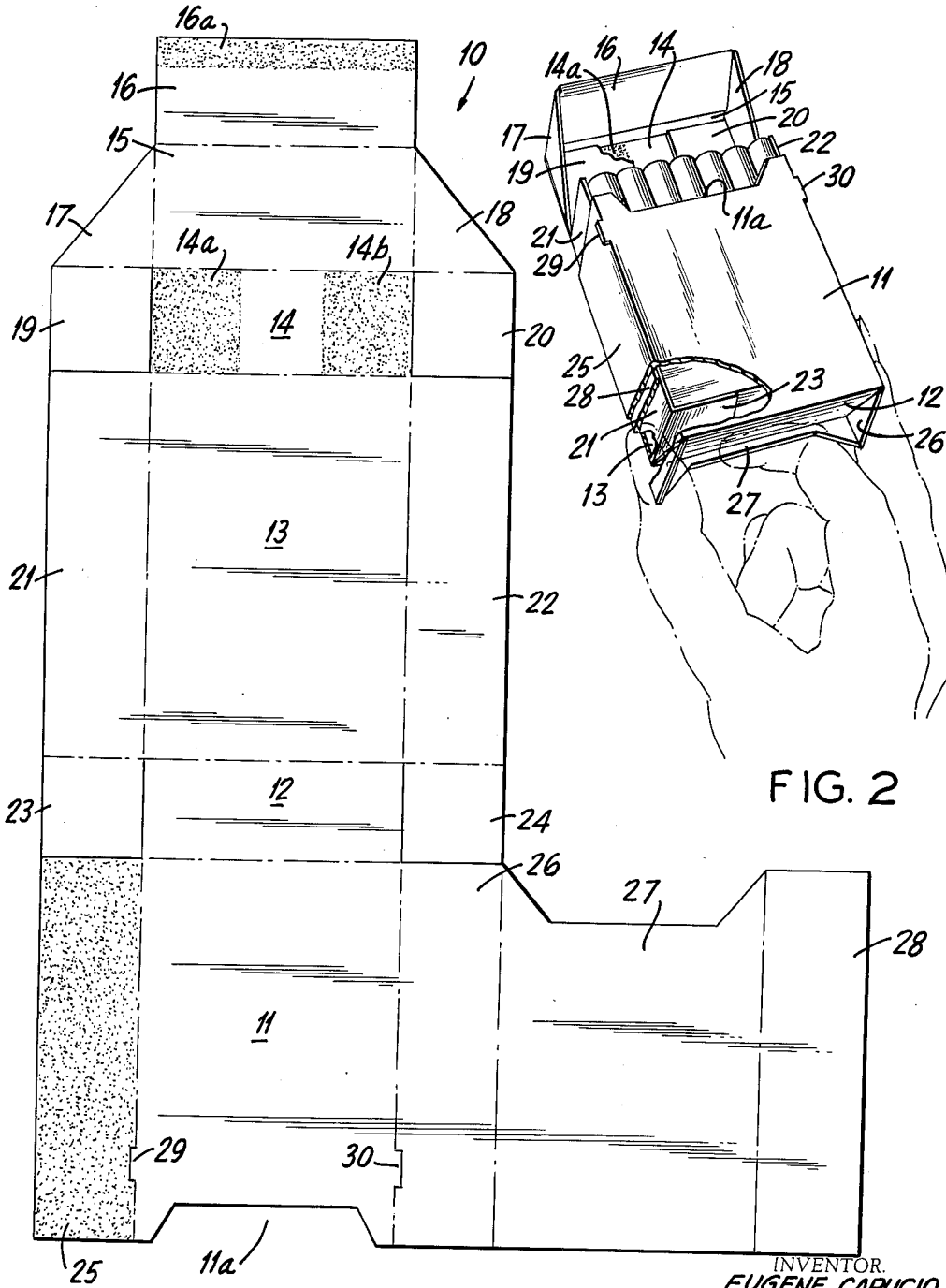

FIG. 2

FIG. 1

INVENTOR.
EUGENE CAPUCIO

BY *Joseph D. Lazar*
ATTORNEY.

Sept. 7, 1965

E. CAPUCIO

3,204,852

FLIP-OPEN CONTAINER

Filed April 10, 1964

2 Sheets-Sheet 2

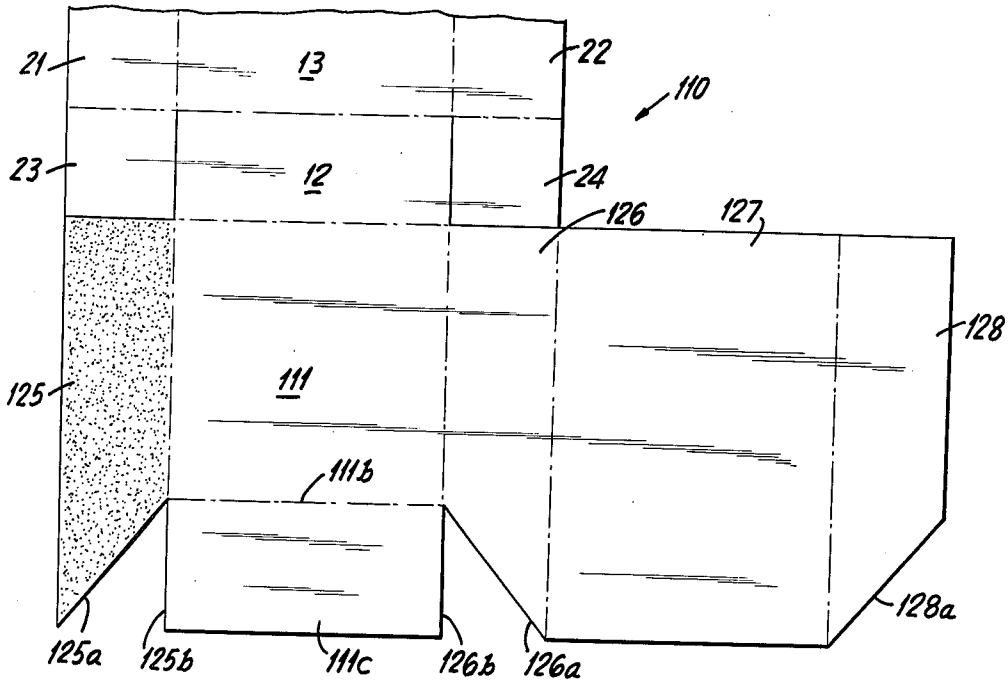

FIG. 3

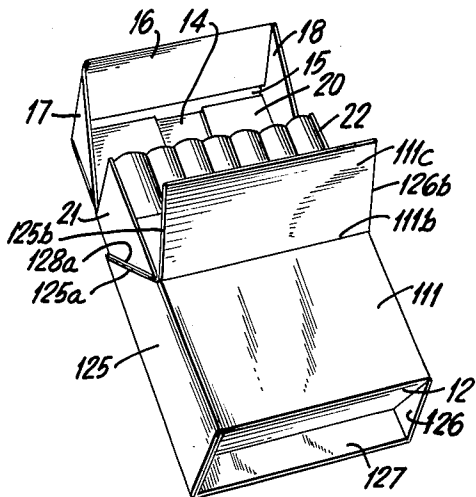

FIG. 4

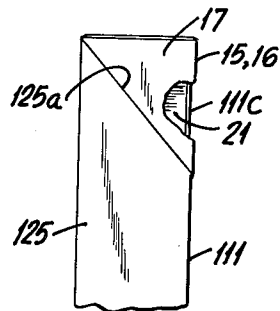

FIG. 5

INVENTOR.
EUGENE CAPUCIO

BY

Joseph D. Lazar

ATTORNEY.

1

3,204,852

FLIP-OPEN CONTAINER

Eugene Capucio, Apartado 1087, Chacao,
Caracas, Venezuela

Filed Apr. 10, 1964, Ser. No. 358,791

1 Claim. (Cl. 229-20)

This invention relates to flip-open containers and more particularly to containers which are adapted to be opened by a force applied to the container at a location spaced from the cover.

Cigarettes and similar merchandise are usually sold for retail consumption in containers having pivotal covers in the form of a hood and, which, because of its shape and resilience relative to the body portion, flip or snap open when urged from the closed position. Such a container is disclosed in my co-pending application Serial No. 203,336, filed June 18, 1962, now U.S. Patent No. 3,132,790. More particularly, I disclose in that application a container having an ejector mechanism by which the cover is flipped open and the contents are urged from within the container. The present invention is an improvement over containers of that type.

In general, my invention contemplates the provision of a unitary blank of foldable material cut in a configuration from which there is formed a container having an inner tray portion carrying the articles for which the container is designed, and being slidable with respect to an outer cover portion. The relative motion of the inner and outer portion is effected by a force applied to one end of the inner portion in a direction along the main axis of the container while the outer portion is restrained relative thereto. This force and the resulting relative movement of the inner and outer portions causes a hooded-lid portion hingedly attached to the inner portion to be opened with snap-like action and also urges the contents outwardly from the container.

While the specific embodiment of my invention to be described is illustrated as a container for cigarettes, it will be appreciated that my invention may be used as a container for other articles of different size or shape.

In the accompanying drawings, in which reference is made to the following detailed description of several embodiments of my invention and in which like reference characters indicate like parts in the various views:

FIGURE 1 is a plan view of the blank used to form the container or box; FIGURE 2 is a perspective view of the box assembled and in open position, including a portion in section to expose certain otherwise hidden portions; FIGURE 3 is a plan view of a modification of the blank of FIG. 1; FIGURE 4 is a perspective view of the box assembled from the blank of FIG. 3; and FIGURE 5 is a side view of the box of FIG. 4 in closed position.

Referring now to the drawing, the box is erected from a blank 10 made of cardboard, plastic or other suitable foldable material. The face of blank 10 as seen in FIG. 1 will, when formed into the box illustrated in FIG. 2, be hidden from the viewer of the box as this face will comprise the inner or inwardly-facing faces of all the sections or portions of the box. Blank 10 is cut or stamped, by a die, for example, from a roll of stock material. Advantageously during the stamping step, cuts represented by solid lines in the drawing and scores, represented by dotted lines in the drawing, are also made on the blank. The portions of the blank provided with cuts define separated extensions of the blank while the scored portions allow for bending or folding those portions contiguous thereto in a hinged manner. It will be noted that all folds or bends are made in the sense that the foldable portions of the box are bolded or bent upwardly toward the viewer from the plane of the drawing about the axis of the bend.

2

Blank 10 comprises, essentially, a front panel 11, a bottom panel 12, an inner rear panel 13, and a lid portion.

The lid portion comprises a top lid panel 14, a front lid panel 15, a front lid tab 16, side lid portions 17 and 18 and lid connectors 19 and 20. Surface portions 14a, 14b and 16a are covered with a tacky material such as glue. These tacky surfaces, indicated on the drawing by stipplings, together with portion 25, are the only portions which need a tacky surface. The lid portion is formed by folding portion 16 over panel 15 and the unseen faces of portions 19 and 20 over portions 14a and 14b respectively as portions 17 and 18 bend toward each other to be, thereby, mutually perpendicular to portion 15.

Inner rear panel 13 includes inner side panels 21 and 22 which respectively are folded so as to be perpendicular to panel 13. Inner bottom wall tabs 23 and 24, pivoting, respectively, about the end of side panels 21 and 22, are folded toward each other so as to be perpendicular to both panel 13 and side panels 21 and 22.

Front panel 11 includes an outer side panel 25 and outer side panel 26, both of which are folded to be perpendicular to panel 11. Connected to panel 26 is outer rear panel 27 and intermediate side wall panel 28. Panels 25, 11, 26, 27 and 28 are folded in the sense to be wrapped about rear panel 13 as panel 11 is folded to a position perpendicular to bottom panel 12, which in turn is folded perpendicular to rear panel 13. Panel 28 is folded under and is glued to panel 25. The box as assembled may be better visualized by referring to FIG. 2 which illustrates in perspective the assembled box in opening position.

In operation, to open the box, the user, while gripping the side walls 25 and 26, applies a force to panel 12 whereby panel 12 pivots relative to panels 11 and 13. The double-pivot action causes panel 13, and its side walls 21 and 22 and tabs 23 and 24, including the lid portion to slide upwardly relative to the outer portions 25, 11, 26, 27 and 28. The lid in its open position is shown in FIG. 2. It is noted that this action of the inner portion moving with respect to the outer portion is similar to conventional drawer-action.

It is also to be noted that bottom wall tabs 23 and 24 are squared between panels 11 and 13 and thus act as stops to prevent movement of panel 13 downwardly relative to panel 11, i.e. in a direction opposite to that of opening the box as just described. Tabs 23 and 24 sliding between panels 11 and 13 also function to limit the upward or opening movement since the bottom panel 12 pivots relative to panels 11 and 13 and is hinged in a plane coincident with the plane of tabs 23 and 24. The extent that panel 12 can be pivoted depends on the resiliency of the box and the amount of movement depends on the length of the portion of panel 11 extending below the tabs 23 and 24. Recess portion 11a, although unnecessary, allows for easy access to the contents of the box.

If the box is used as a container for rod-like members such as cigarettes, such cigarettes may preferably be wrapped in a liner material as known in the art to preserve their flavor and freshness. The liner also serves to prevent cigarettes from dropping between the gap of tabs 23 and 24 if the dimensions of those tabs are chosen to be so short as not to meet.

It will be appreciated that the box of the invention may be used for a variety of uses and accordingly the relative dimensions of the several portions may be made according to the requirements of the contents. Thus if tab portions 23 and 24 must cover the bottom of the box and would not if, for example, panel 12 were too wide, panels 25 and 26 may be reduced in length whereby tabs 23 and 24 are made longer sufficient to cover together the bottom of the box.

In order to improve the snap-open action and the restrained closed position of the lid portion, ears 29 and 30

are provided along the intersection of the front and side walls of the container within the portion which will contact the lid. As seen in FIG. 2, these ears project outwardly from the corner edge when the panels 11, 25 and 26 are folded and will frictionally and resiliently engage the inside surfaces of the lid when the lid is in the closed position. These ears tend to hold the lid in place and, when the lid is being forced open, will tend to restrain the lid from opening until a sufficient movement overcomes the action of the ears to effect thereby a snap-action opening of the lid.

Referring now to FIG. 3, blank 110 is a modification of blank 10, just described, and is illustrated as a fragmentary portion comprising those panels which differ from those of blank 10. The panels which differ from those of blank 10 above described are referenced with a numeral respectively increased by one hundred. Blank 110, when formed into the carton, illustrated by FIG. 4, provides a lid portion which, when in closed position, smoothly mates and butts the outer side and front walls as seen in FIG. 5. This is effected by providing a triangular cut-out at the top ends of panels 25 and 26 of blank 10 (FIG. 1), forming panel portions 125 and 126 in blank 110. Ends 125a and 126a are parallel respectively with the diagonal ends of portions 17 and 18 (see FIG. 1) and will abut the same respectively when the box is formed and the lid is closed. End 128a of panel 128 is parallel with end 125a of panel 125 and will be coincident with end 125a to provide another abutment for lid panel 17 (see FIG. 5). In addition, panel 111 is upset during the blank-stamping operation along crease-line 111b whereby upper portion 111c is recessed or displaced by an amount substantially equal to two thicknesses of the blank material. Accordingly, the double thickness of the lid front, comprising panel 15 and tab 16, will seat over the recessed portion 111c and thereby abut the main portion of panel 111 at the crease-line 111b.

Panel 111c serves as a flap which is foldable outwardly (see FIG. 4) from its closed position about the crease-line 111b providing for access to the contents of the container. If desired a cut-out such as 11a of blank 10 (FIG. 1) may be provided in panel 111c for access to the contents of the box without the need of folding it back.

Flap 111c may be widened to effect an increased drag effect on the lid from the lid's closed position by making cuts 125b and 126b at an angle more acute with cuts 125a and 126a respectively than shown in the drawing. Panel 111c, thus, will be trapezoidal rather than rectangular.

Panel 127, it is noted, is substantially rectangular whereby there is no recess portion as provided in panel 27 of blank 10. As a result, as seen in FIG. 4, the user must apply force to panel 12 within the outer cover panels 125, 126 and 127. The form of panel 27, it is to be understood, may be substituted for that of panel 127 if desired.

Blank 110 is formed into a container as illustrated by FIG. 4 in a manner described above for the fabrication of blank 10 into the container illustrated by FIG. 2. The use of the container shown in FIG. 4 is believed apparent in view of the above description.

It will be understood that various changes may be made in details within the scope of my claim without departing from the spirit of my invention. It is therefore to be understood that my invention is not to be limited in the specific details shown and described.

Having thus described my invention,

I claim:

A box formed from a unitary blank of foldable material comprising

- (a) a tray portion of generally rectangular cross section having an open top and including a bottom wall and a pair of opposed side walls,
- (b) an outer cover having a top wall arranged to cover the open top of said tray, two outer side walls pivotally extending from said top wall arranged to cover the side walls of said tray, a bottom wall pivotally extending from one of said outer side walls arranged to cover the bottom wall of said tray, and a connecting tab pivotally extending from said bottom wall and attached by an adhesive to the other of said outer side walls whereby said outer cover slidably covers said tray,
- (c) an end wall pivotally extending from the bottom of said tray and from the top wall from said outer cover whereby said tray is slidable within said outer cover and connected thereto said end wall having a pair of extension tabs adapted to overlie the inner surface of said end wall,
- (d) a lid section hingedly extending from said tray portion and proportioned to cover the open end of said tray and a portion of said outer cover, said lid section having
- (e) a lid wall pivotally extending from the end of said bottom wall of said tray portion opposed from said end wall, and
- (f) a front lid wall extending from said lid wall and adapted to overlie a portion of the top wall of said outer cover,
- (g) said top wall of said outer cover being upset with a step-recess such that said front lid wall is received in said recess whereby said front lid wall abuts the remaining portion of said outer cover top wall when said lid section is in closed position.

References Cited by the Examiner

UNITED STATES PATENTS

1,824,491	9/31	Molins	-----	229—20
1,928,889	10/33	Guyer	-----	229—20

FOREIGN PATENTS

338,533	10/34	Italy.
---------	-------	--------

FRANKLIN T. GARRETT, *Primary Examiner.*