



(22) **Date de dépôt/Filing Date:** 2008/07/08  
 (41) **Mise à la disp. pub./Open to Public Insp.:** 2009/01/11  
 (45) **Date de délivrance/Issue Date:** 2017/07/04  
 (62) **Demande originale/Original Application:** 2 636 976  
 (30) **Priorités/Priorities:** 2007/07/11 (US60/959,054);  
 2008/06/24 (US12/144,696)

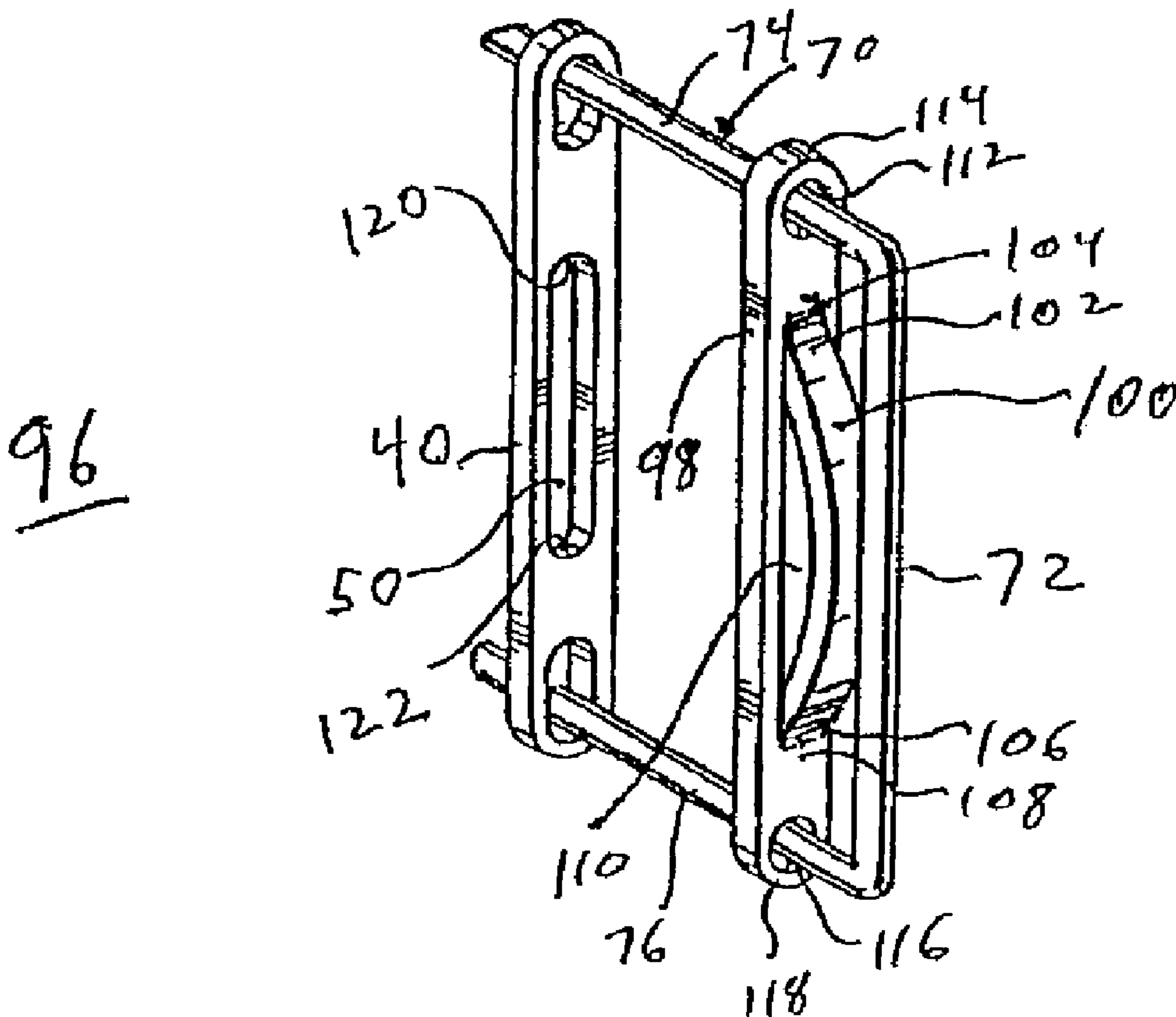
(51) **Cl.Int./Int.Cl. A61B 17/064** (2006.01),  
**A61B 17/068** (2006.01), **A61B 17/072** (2006.01)

(72) **Inventeurs/Inventors:**  
 SOLTZ, MICHAEL, US;  
 SNIFFIN, KEVIN, US;  
 BROOM, JENNIFER, US;  
 HOLSTEN, HENRY E., US

(73) **Propriétaire/Owner:**  
 TYCO HEALTHCARE GROUP LP, US

(74) **Agent:** OSLER, HOSKIN & HARCOURT LLP

(54) **Titre : AGRAFE CHIRURGICALE AVEC ZONE DE COMPRESSION ACCRUE**  
 (54) **Title: SURGICAL STAPLE WITH AUGMENTED COMPRESSION AREA**



(57) **Abrégé/Abstract:**

A surgical staple assembly comprising: a staple having a backspan and a pair of legs extending from the backspan, each of the legs terminating in a tissue penetrating tip; a plate having openings for receipt of the legs of the staple, wherein the plate includes a biasing member, the biasing member being engagable with the backspan of the staple to bias the plate away from the backspan.

## **ABSTRACT**

A surgical staple assembly comprising: a staple having a backspan and a pair of legs extending from the backspan, each of the legs terminating in a tissue penetrating tip; a plate having openings for receipt of the legs of the staple, wherein the plate includes a biasing member, the biasing member being engagable with the backspan of the staple to bias the plate away from the backspan.

## SURGICAL STAPLE WITH AUGMENTED COMPRESSION AREA

This application is a division of Canadian Serial No. 2,636,976 filed July 8, 2008.

### BACKGROUND

#### 1. Technical field

The present disclosure relates to a multi-part surgical staple assembly. More particularly, the present disclosure relates to a multi-part surgical staple assembly having augmented compression areas to provide uniform compression across a staple line in tissue.

#### 2. Background of Related Art

During surgical procedures involving operations on tubular tissue sections it is often necessary to cut or segment the tubular tissue sections and staple them closed. One instance of this type surgery involves cutting out a diseased section of a tubular tissue section such as, for example, a section of a colon and temporarily staple of the healthy, free ends of the tubular tissue section closed prior to reattaching them together. A line or row of staples is typically placed across the tubular tissue section. In some instances, fluid pressure remains within the tubular tissue sections and exerts stresses or forces on the staple lines placed across the tubular tissue sections.

Failure at the tissue line may occur resulting in the luminal contents leaking into the abdominal cavity potentially causing morbidity or mortality. Failures such as these have been attributed to the staple interaction with the underlying tissue. Leaks may form either through the staple penetration holes through the tissue or between the compressed layers of tissue themselves.

In addition, during the wound healing processes of the stapled tissues, the mechanical strength of the tissues may decrease over time. The decrease in mechanical strength corresponds to a decrease in compressive properties within the tissues resulting in the possibility of leakage. Further, there exists the relationship between the leak pressure of an anastomosis or staple line junction and the amount of clamping pressure applied by the staples. If the pressure within the lumen exceeds the compressive stresses, then a leak will form. This can be represented by the formula  $P > \sigma t/r$  where  $P$  is the pressure within the lumen,  $\sigma$  is the compressive stress,  $t$  is the thickness of the tissue and  $r$  is the radius of the tubular tissue section.

Therefore, it would be desirable to provide a staple assembly capable of reducing leakage through tissue about staple legs of the staple assembly. It would further be desirable to provide a staple assembly capable of applying uniform compression across the areas of tissue secured by a staple of the staple assembly. It would still further be desirable to provide a staple assembly capable of compensating for losses in mechanical strength of the underlying tissue by maintaining constant compression levels on the stapled tissue.

## SUMMARY

There is disclosed a surgical staple assembly for providing uniform compression to opposed sides of a stapled tissue section. The surgical staple assembly includes a staple having a backspan and a pair of legs extending from the backspan, each of the legs terminating in a tissue penetrating tip. The surgical staple assembly also includes a first compression member having first openings for receipt of the legs of the staple and a second compression member having second openings for receipt of the legs of the staple. In use, the first compression member applies a first compressive force to a first side of a tissue section penetrated by the legs of the staple and the second compression member applies a second compressive force to a second side of the tissue section penetrated by the legs of the staple.

The first compression member is a generally flat plate having a length greater than a length of the back span of the staple and a width greater than a diameter of the material forming the staple. The second compression member is a platen having width greater than the diameter of the material forming the staple.

The platen preferably further includes at least one third opening for accommodating the tissue penetrating tips of the staple. The at least one third opening is preferably positioned adjacent the center of the platen. In one embodiment, the at least one third opening is an oval opening for receipt of the tissue penetrating tips of the staple.

In one embodiment of the surgical staple assembly, the plate includes a biasing member engagable with the backspan of the staple to bias the plate away from the backspan. In one

embodiment, the biasing member is a leaf spring. The leaf spring may be formed integral with the plate or, alternatively, one end of the leaf spring may be affixed to the plate.

There is also disclosed a surgical staple assembly including a staple having a backspan and a pair of legs extending from the backspan, each of the legs terminating in a tissue penetrating tip and a plate having openings for receipt of the legs of the staple. The plate includes a biasing member engagable with the backspan of the staple to bias the plate away from the backspan. The biasing member is a leaf spring and in one embodiment, the leaf spring is formed integral with the plate while in an alternative embodiment, one end of the leaf spring is affixed to the plate.

There is further disclosed a surgical staple assembly including a staple having a backspan and a pair of legs extending from the backspan, each of the legs terminating in a tissue penetrating tip and a platen having first openings for receipt of the legs of the staple and at least one second opening for receipt of the tissue penetrating tips of the staple.

The at least one second opening is positioned between the first openings. Preferably, the at least one second opening is positioned in the center of the platen. In a particular embodiment, the at least one second opening is an oval opening for receipt of the tissue penetrating tips of the staple.

There is also disclosed an anvil for use with a surgical staple assembly incorporating a compression member. The anvil includes a plate having first staple clinching pocket and a second staple clinching pocket spaced apart from the first staple clinching pocket and at least one recess formed in the plate and extending from one of the first and second staple clinching pockets. The at least one recess is provided for receipt of an end of a compression member associated with a surgical staple assembly. In a specific embodiment, the at least one recess includes a first recess formed adjacent the first staple clinching pocket and a second recess formed adjacent the second staple clinching pocket.

In one embodiment of the anvil, the first staple clinching pocket includes a first center point, the first recess includes a first recess center point and the second staple clinching pocket includes a second center point. The first center point, first recess center point and the second center point preferably lie along a common axis.

The plate further includes a central recess intermediate the first and second staple clinching pockets. The central recess has a raised portion, such that the raised portion is positioned beneath a central opening in the compression member.

#### **DESCRIPTION OF THE DRAWINGS**

Various embodiments of the presently disclosed augmented compression surgical staple are disclosed herein with reference to the drawings, wherein:

FIG. 1 is a perspective view of a surgical stapler incorporating one embodiment of an augmented compression surgical staple and associated anvil;

FIG. 2 is an enlarged area of detail of FIG. 1 illustrating anvil and staple assembly components;

FIG.3. is an enlarged area of detail view of FIG. 1 illustrating a staple clinching pocket of the anvil and a platen of the staple assembly;

FIG. 4 is a perspective view, similar to FIG. 3, with the platen separated from the staple pocket;

FIG. 5 is a perspective view of a first embodiment of the staple assembly prior to formation;

FIG. 6 is a side view of the platen of Figure 5;

FIG. 7 is a side view of the assembled and formed staple assembly of Figure 5;

FIG. 8 is a perspective view of an alternate embodiment of a staple assembly prior to formation;

FIG. 9 is a side view of the staple assembly of FIG. 8 in the formed condition;

FIG. 10 is a perspective view of another embodiment of a staple assembly prior to formation;

FIG. 11 is a side view of the staple assembly of FIG. 10 in the formed condition;

FIG. 12 is a perspective view of the surgical instrument of FIG. 1 positioned about a tissue section;

FIG. 13 is a side view, partially shown in section, of the tissue section captured between the anvil and staple head of the surgical stapler;

FIG. 14 is a side view, partially shown in section, illustrating a staple of the staple assembly being driven through the tissue section;

FIG. 15 is a perspective view of the staple assembly securing the tissue section and in the formed condition;

FIG. 16 is a side view, partially shown in section, of the staple assembly of FIG. 8 being driven through a tissue section; and

FIG. 17 is a perspective view of the staple assembly of FIG. 16 securing the tissue section and in the formed condition.

#### **DETAILED DESCRIPTION OF EMBODIMENTS**

Embodiments of the presently disclosed surgical staple assembly and associated anvil for forming the surgical staple assembly will now be described in detail with reference to the drawings wherein like numerals designate identical or corresponding elements in each of the several views. As is common in the art, the term "proximal" refers to that part or component closer to the user or operator, i.e. surgeon or physician, while the term "distal" refers to that part or component further away from the user.

Referring initially to FIG. 1, there is disclosed an anvil 10 for use with a surgical stapler 12. Surgical stapler 12 is of the type typically used for open surgery procedures and includes a pistol grip handle 14 having an elongate member 16 extending distally from handle 14. Elongate member 16 terminates in a generally U-shaped anvil support 18. Anvil 10 is mounted on anvil support 18. Surgical stapler 12 also includes a staple containing head or staple cartridge 20 which contains a plurality of staples as described in more detail hereinbelow. An adjustment knob 22 is provided on handle 14 and operates to move staple head 20 relative to anvil 10 in

known manner in order to approximate the staple cartridge and anvil to capture the tissue to be stapled therebetween. A trigger 24 is provided to actuate stapler 12 and eject staples out of staple head 20, through tissue and into anvil 10. A trigger lock 26 is provided to prevent movement of trigger 24 and thus premature actuation of surgical stapler 12. Although shown as an open-type surgical stapler, it is contemplated that the present disclosure can be readily used on any type of surgical stapler, ether open or endoscopic type staplers. Also, other mechanisms to approximate the staple head and to fire the staples can be utilized.

Referring now to FIG. 2, anvil 10 includes an anvil plate 28 which is mounted to anvil support 18. Anvil plate 28 defines a plurality of staple forming pockets 30 which cooperate with staple head 20 to form, and support part of, a staple assembly. Anvil plate includes an alignment pin 32 and an alignment recess 34 which cooperate with a corresponding recess and pin on staple head 20 to ensure staples contained within staple head 20 are in proper alignment with staple forming pockets 30 during stapling of tissue.

With reference to FIG. 3, each staple forming pocket 30 generally includes a first staple clinching depression or pocket 36 and a second staple clinching pocket 38 spaced apart from first staple clinching pocket 36. Pockets 36 and 38 are provided to receive tips of a staple and direct them toward a platen 40, associated with the surgical staple assembly, positioned within staple forming pocket 30. Platen 40 is formed as a generally elongated plate having a first hole 42 adjacent a first end 44 of platen 40 and a second hole 46 adjacent a second end 48 of platen 40. First and second holes 42 and 46 are provided to receive the legs of a surgical staple therethrough and direct them into first and second staple clinching pockets 36 and 38,

respectively. Platen 40 further includes an opening 50 which is generally oval in shape and provided centrally along platen 40. Opening 50 is provided to receive, upon staple formation, tissue penetrating tips of the surgical staple associated with the surgical staple assembly in a manner described in more detail hereinbelow.

As shown in FIG. 4, staple forming pocket 30 is provided with a narrowed central area or recess 52 located between first and second staple clinching pockets 36 and 38. A hump or protrusion 54 is located within recess 52 to assist in forming the staple of the surgical staple assembly. Recess 52 is located directly beneath opening 50 of platen 40 to direct the tips of the surgical staple associated with the surgical staple assembly through opening 50 of platen 40.

Platen 40 is frictionally retained within staple forming pocket 30. Staple pocket 30 includes a first retention recess 56 formed adjacent first staple clinching pocket 36 and a second retention recess 58 formed adjacent second staple clinching pocket 38. First and second ends 44 and 48 of platen 40 are frictionally retained within first and second retention recesses 56 and 58 of staple forming pocket 30, respectively.

In a particular embodiment, first retention recess 56 includes a first retention center point 60, first staple clinching pocket 36 includes a first center point 62, second staple clinching pocket 38 includes a center point 64 and second retention recess 58 includes a second retention center point 66. As shown, in this particular embodiment, first retention center point 60, first center point 62 and second center point 64 lie along a common axis X-X. In a preferred embodiment, second retention center point 66 also lies along common axis X-X.

Referring now to FIG. 5, there is disclosed a novel, multi-part staple assembly 68, including platen 40, capable of providing uniform compression along opposed sides of stapled tissue. Staple assembly 68 includes a generally U-shaped staple 70. Staple 70 can be of a known type commonly used in the surgical arts and generally includes a backspan 72 and first and second legs 74 and 76 extending from first and second ends 78 and 80, respectively, of backspan 72. First and second legs 74 and 76 terminate in first and second tissue penetrating tips 82 and 84, respectively. Preferably, the legs 74, 76 are substantially parallel to the backspan, although alternatively they can be positioned at an angle to the backspan.

In order to provide uniform compression along both sides of tissue to be stapled, staple assembly 68 further includes a staple plate 86. Staple plate 86 is provided with a first plate hole 88 at a first end 90 thereof and a second plate hole 92 formed in a second end 94 of staple plate 86. First and second plate holes 88 and 92 are provided to receive staple legs 74 and 76 therethrough. It should be noted that the overall lengths of platen 40 and staple plate 86 are preferably longer than the backspan 72 of staple 70 and the widths of platen 40 and staple plate 86 are preferably wider than the diameter of the material forming surgical staple 70. It should be further noted that the provision of platen 40 and staple plate 86 augment the compression area which would otherwise be provided on stapled tissue by surgical staple 70 alone.

Referring for the moment to FIG. 6, platen 40 is illustrated in cross-section. As shown, central opening 50 is located intermediate first and second holes 42 and 46 in platen 40. In the embodiment specifically illustrated, central opening 50 is located centrally along the length of

platen 40 so as to receive any excess length of tissue penetrating tips 82 and 84 as they are formed within staple forming pocket 30 of anvil 10.

Referring now to FIG. 7, upon being formed within a surgical stapling apparatus, surgical staple 70 is formed into a typical B-shape. As shown, leg 74 of surgical staple 70 passes through first plate hole 88 in staple plate 86 and through first hole 42 in platen 40. Similarly, second leg 76 passes through second plate hole 92 in staple plate 86 and through second hole 46 in platen 40. Upon being formed within staple forming pocket 30 of anvil 10, tissue penetrating tips 74 and 76 are recurved back towards backspan 72 of staple 70 and may pass through central opening 50 depending on the particular thickness of the tissue being stapled. This allows surgical staple assembly 68 to accommodate various thicknesses of tissue. For example, when used with particularly thin tissue sections, the passage of tissue penetrating tips 74 and 76 through central opening 50 take-up any excess length in staple legs 74 and 76 and allow complete compression of the stapled tissue sections.

Turning now to FIG. 8, there is disclosed in alternative embodiment of a surgical staple assembly 96 incorporating platen 40 and surgical staple 72 substantially as described hereinabove. Surgical staple assembly 96 includes an alternate embodiment of a staple plate 98 having a biasing member 100 which is provided to urge staple plate 98 away from backspan 72 of surgical staple 70. The provision of biasing member 100 on staple plate 98 allows staple plate 98 to provide a consistent degree of pressure against underlying stapled tissues. This is particularly useful when, as noted above, the stapled tissue loses mechanical strength due to compression, degradation, necrosis, etc. over time. That is, should the stapled tissue weaken

over time, surgical staple assembly 96 provides sufficient compression to prevent any leakage through the underlying stapled tissue sections until such time as the underlying tissue sections have properly healed.

In this particular embodiment, biasing member 100 is integrally formed with staple plate 98. Staple plate 98 may be formed of any suitable material capable of providing a certain amount of flexion within biasing member 100. Biasing member 100 may be formed in staple plate 98 by stamping, molding, etc. Biasing member 100 includes a first end 102 extending from a first point 104 on staple plate 98 and extending to a second end 106 at a second point 108 on staple plate 98. When biasing member 100 is stamped, punched or otherwise cut from staple plate 98, the material occupied by biasing member 100 results in an opening 110 formed in staple plate 98. It should be noted that, while biasing member 100 is disclosed as being connected at first and second ends 102 and 106 to staple plate 98, one of first end 102 or second end 106 may be cut or otherwise disconnected from staple plate 98 to allow a greater degree of flexion, and thus of biasing force, of biasing member 100. In this instance, biasing member 100 generally functions as a leaf spring. Also, biasing member can be provided as a separate element attached to the backspan of the staple as described below.

Staple plate 98 additionally includes a first hole 112 formed at a first end 114 of staple plate 98 and a second hole 116 formed at a second end 118 of staple plate 98. First and second holes 112 and 116 are provided to receive staple legs 74 and 76 therethrough in a manner similar to that described hereinabove with respect to staple plate 86.

As best shown in FIG. 9, when surgical staple assembly 96 is fully formed, first and second legs 74 and 76 extend through first and second holes 112 and 116, respectively, in staple plate 98, through holes 42 and 46 in plate 40, 40 (and through opening 50 depending on tissue thickness). As described hereinabove with regard to surgical staple assembly 68, fully formed staple 70 of Figure 9 assumes a general B- shape with tissue penetrating tips 82 and 84 extending through first and second holes 42 and 46 in platen and curving back through opening 50.

As noted hereinabove, platen 40 is initially retained within anvil 10. Common to all the staple assembly embodiments disclosed herein, as surgical staple 70 is formed into a general B- shape within staple forming pocket 30 of anvil 10, tissue penetrating tips 82 and 84 engage first and second edges 120 and 122, respectively, of central opening 50 in platen 40. The engagement of tissue penetrating tips 82 and 84 with edges 120 and 122 function to force or "pop" platen 40 free from its friction fit within staple forming pocket 30. It should also be appreciated that contact with other portions or structure can be utilized to release the platen 40 from the staple forming pocket.

Referring now to FIGS. 10 and 11, there is disclosed another embodiment of a surgical staple assembly 124 including platen 40 and surgical staple 70 substantially as described hereinabove. Surgical staple assembly 124 includes a staple plate 126 having a biasing member 128 affixed to staple plate 126. Biasing member 128 may be affixed to staple plate 126 by welding, gluing, etc. As with biasing member 100 hereinabove, biasing member 128 may be affixed to staple plate 126 at only one end and function as a leaf spring. Additionally, biasing member 128 may be formed of a material different from that of staple plate 126. Similar to the

staple plates described hereinabove, staple plate 126 includes a first hole 130 formed in a first end 132 of staple plate 126 and a second hole 134 formed in a second end 136 thereof. As with staple plate 98 described hereinabove, biasing member 128 is provided to urge staple plate 126 away from backspan 72 and toward surgical staple 70 to provide a consistent pressure of staple plate 126 against underlying stapled tissue.

Referring now to FIGS. 12-15, and initially with regard to FIG.12, the use of staple assembly 68 and anvil 10, incorporated into surgical stapler 12, to staple a tubular tissue T will now be described. It should be noted that, while the following discussion of the use of staple assembly 68 and anvil 10 is given in connection with an open surgery style surgical stapler 12, staple assembly 68 and anvil 10 find equal application when used in other types of surgical staplers, such as, for example, linear staplers, endoscopic or laparoscopic staplers, circular or anastomotic staplers, etc. Further, staple assembly 68 and anvil 10 are equally suited for use in stapling tissues other than tubular tissue sections and need not necessarily be used in conjunction with one another.

Surgical stapler 12 is provided with a plurality of staples 70 and staple plates 86 loaded in staple cartridge 20 in a manner discussed in more detail hereinbelow. The staple cartridge is preferably removable and replaceable after firing with another loaded cartridge. Surgical stapler 12 is initially placed such that tissue section T is positioned between anvil 10 and staple head 20. Thereafter, adjustment (approximation) knob 22 is manipulated to move staple cartridge 20 toward anvil 10 and capture tissue T therebetween.

As shown in FIG. 13, captured tubular tissue T is captured and compressed between anvil 10 and approximated staple cartridge 20 to close lumen L in tubular tissue T. Upon movement of staple cartridge 20 toward anvil 10, alignment pin 32 on anvil plate 28 enters a recess 138 in staple cartridge 20 and a staple head pin 140 on staple head 20 enters alignment recess 34 in anvil plate 28 to ensure proper alignment of staple legs 74 and 76 with staple clinching pockets 36 and 38, respectively. As noted above, staple cartridge 20 is provided with a plurality of staples 70 and staple plates 86 arranged in one or more linear rows. Specifically, staples 70 are contained within staple pockets, such as staple pocket 142, formed in staple cartridge 20. A pusher 144 is positioned within staple pocket 142 and is movable within staple pocket 142 in response to actuation of trigger 24 of surgical stapler 12. Movement of pusher 144 within staple pocket 142 causes pusher 144 to engage backspan 72 of staple 70 and drive staple 70 out of staple head 20 toward anvil 10. The plurality of staples 70 contained in the cartridge can be fired substantially simultaneously, fired sequentially, or combinations of both.

Staple plate 86 is frictionally retained within a staple plate recess 146 formed in staple cartridge 20 and positioned over staple pocket 142 in order to position staple plate 86 in front of staple 70.

Referring now to FIGS. 12 and 14, once surgical stapler 12 has been positioned about tissue T, lock lever 26 is disengaged from trigger 24 and trigger 24 is actuated (FIG. 12) to cause driver 144 to move distally within staple pocket 142 (FIG. 14). It should be understood, that for convenience, Figures 13 and 14 shown the firing of only one of the plurality of staples contained in the stapling instrument. With continued reference to FIG. 14, pusher 144 drives staple 70

distally within staple pocket 142 such that tissue penetrating tips 82, 84 pass through holes 88 and 92 in staple plate 86 as described hereinabove (FIG. 7) and thereafter through tissue T. After penetrating tissue T, tissue penetrating tips 82 and 84 pass through holes 42 and 46 in platen 40 (FIG. 7) and are formed within staple clinching pockets 36 and 38 in anvil plate 28. As noted hereinabove, engagement of tips 82 and 84 with protrusion 54 cause tips 82 and 84 to recurve back toward backspan 72 of staple 70 and pass through central opening 50 formed in platen 40.

Upon full actuation of surgical stapler 12, pusher 144 urges staple 70 out of staple pocket 142 which in turn pushes staple plate 86 free of its frictional engagement within staple plate recess 146 in staple head 20 thereby releasing staple 70 and staple plate 86 from staple head 20. As discussed hereinabove, engagement of tissue penetrating tips 82 and 84 with edges of central opening 50 in platen 44 force or "pop" platen 40 free of its frictional engagement in staple forming pocket 30.

Surgical staple assembly 68, fully formed and closing lumen L of tissue T, is best illustrated in FIG. 15. The provisions of platen 40 and staple plate 86 in surgical staple assembly 68 provide a greater, and more uniform, compression area to tissue T.

Referring for the moment to FIGS. 16 and 17, surgical staple assembly 96 is assembled within surgical stapler 12 and driven through tubular tissue section T in a manner substantially identical to that described hereinabove with respect to surgical staple assembly 68. For example, pusher 144 drives staple 72 out of staple pocket 142, through staple plate 98 and tissue T. Thereafter, tissue penetrating tips 82 and 84 pass through platen 40 to fully form surgical staple

assembly 96 about tissue T. As noted hereinabove, surgical staple assembly 96 includes biasing member 100 to provide a constant pressure of staple plate 98 against tissue T over time. This ensures a constant level of pressure force against stapled tissue T by staple plate 86 and platen 40 thereby helping to prevent any leakage through lumen L in the event that the structural strength of tissue T degrades and the thickness of tissue T decreases over time. Again, for convenience, only one of the plurality of staple assemblies 96 is shown in the Figures.

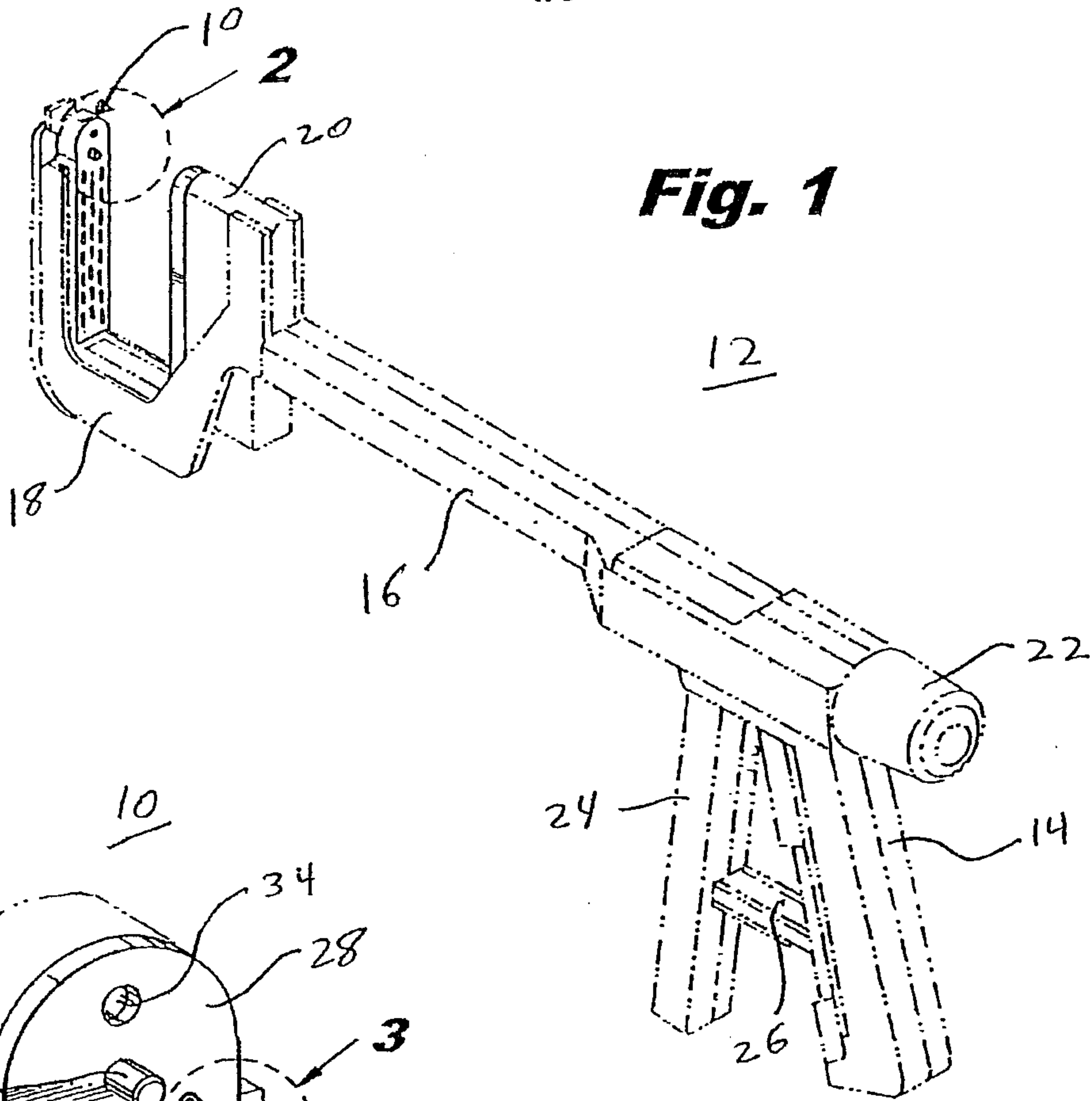
While not specifically shown, it should be noted that surgical staple assembly 124, including biasing member 128, functions substantially identically to surgical staple assembly 96.

It will be understood that various modifications may be made to the embodiments disclosed herein. For example, the disclosed platens may take other shapes and sizes and do not necessarily need to be longer than the overall length of the backspan of the staple used therewith. Further, the disclosed platens may be formed without a central opening to provide a greater surface area for compression against a stapled tissue section. Additionally, biasing members may also be provided on the platen to urge the platen away from the legs or tissue penetrating tips of the staples and towards the tissue section to provide a constant source of pressure against the stapled tissue section overtime. Therefore, the above description should not be construed as limiting, but merely as exemplifications of particular embodiments. The scope of the claims should not be limited by the preferred embodiments set forth herein, but should be given the broadest interpretation consistent with the description as a whole.

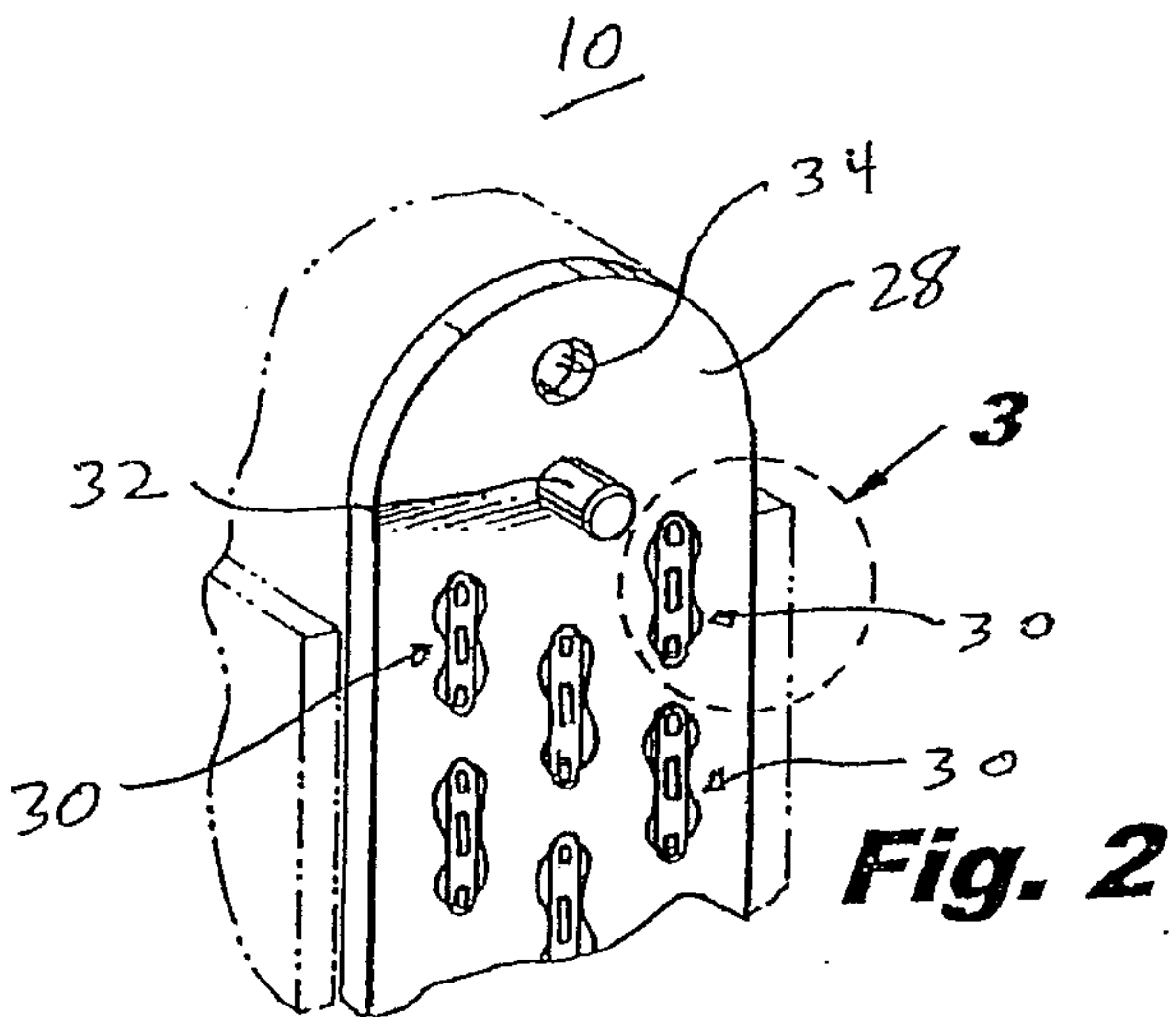
The embodiments of the present invention for which an exclusive property or privilege is claimed are defined as follows:

1. A surgical staple assembly comprising:
  - a staple having a backspan and a pair of legs extending from the backspan, each of the legs terminating in a tissue penetrating tip;
  - a plate having openings for receipt of the legs of the staple, wherein the plate includes a biasing member, the biasing member being engagable with the backspan of the staple to bias the plate away from the backspan
2. The surgical staple assembly as recited in claim 1, wherein the biasing member is a leaf spring.
3. The surgical staple assembly as recited in claim 2, wherein the leaf spring is formed integral with the plate.
4. The surgical staple assembly as recited in claim 2, wherein one end of the leaf spring is affixed to the plate.
5. The surgical staple assembly as recited in any one of claims 1 to 4, further including a platen having openings for receipt of the legs of the staple, the plate being receivable between the backspan and the platen to compress tissue.

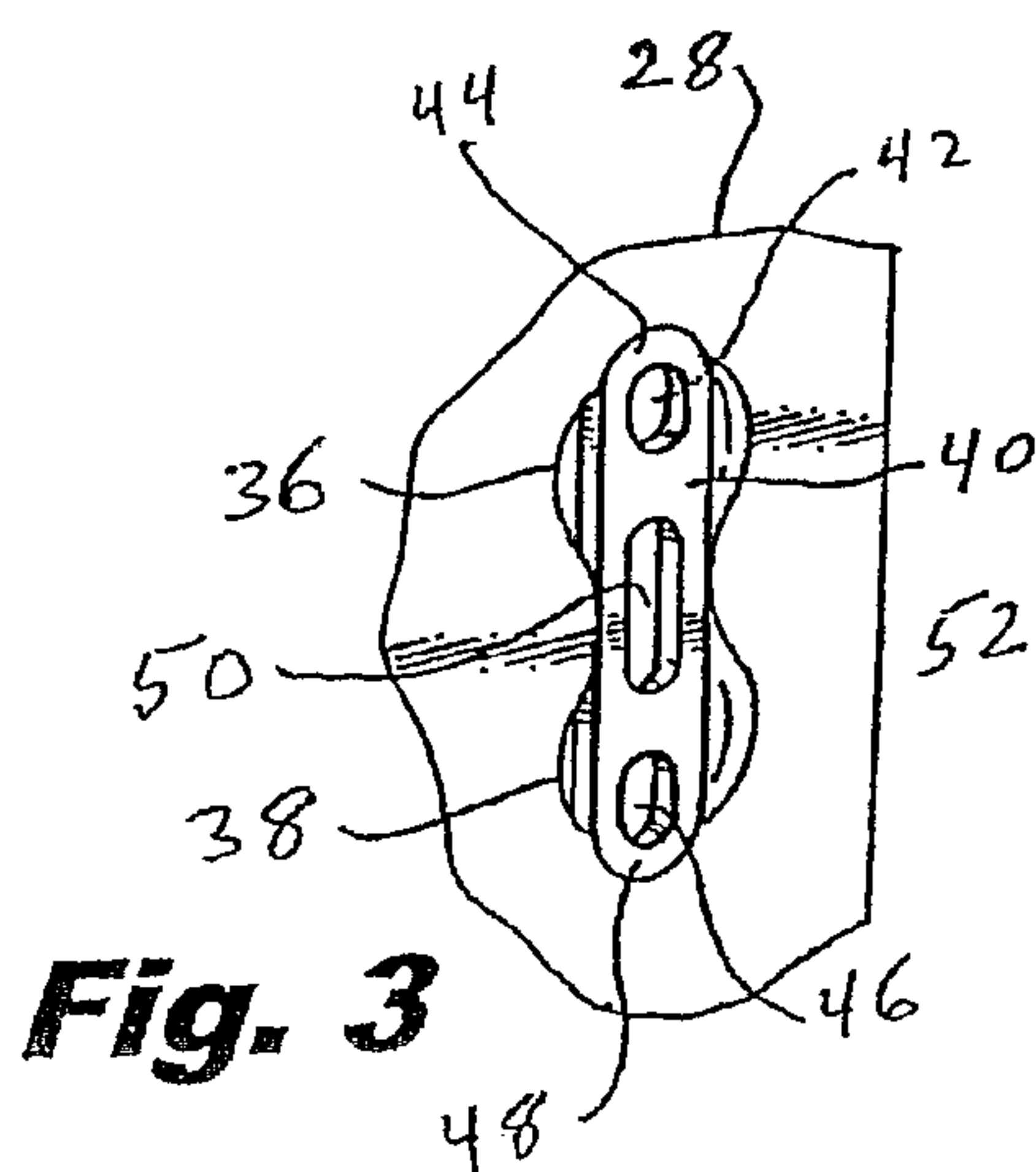
1/5



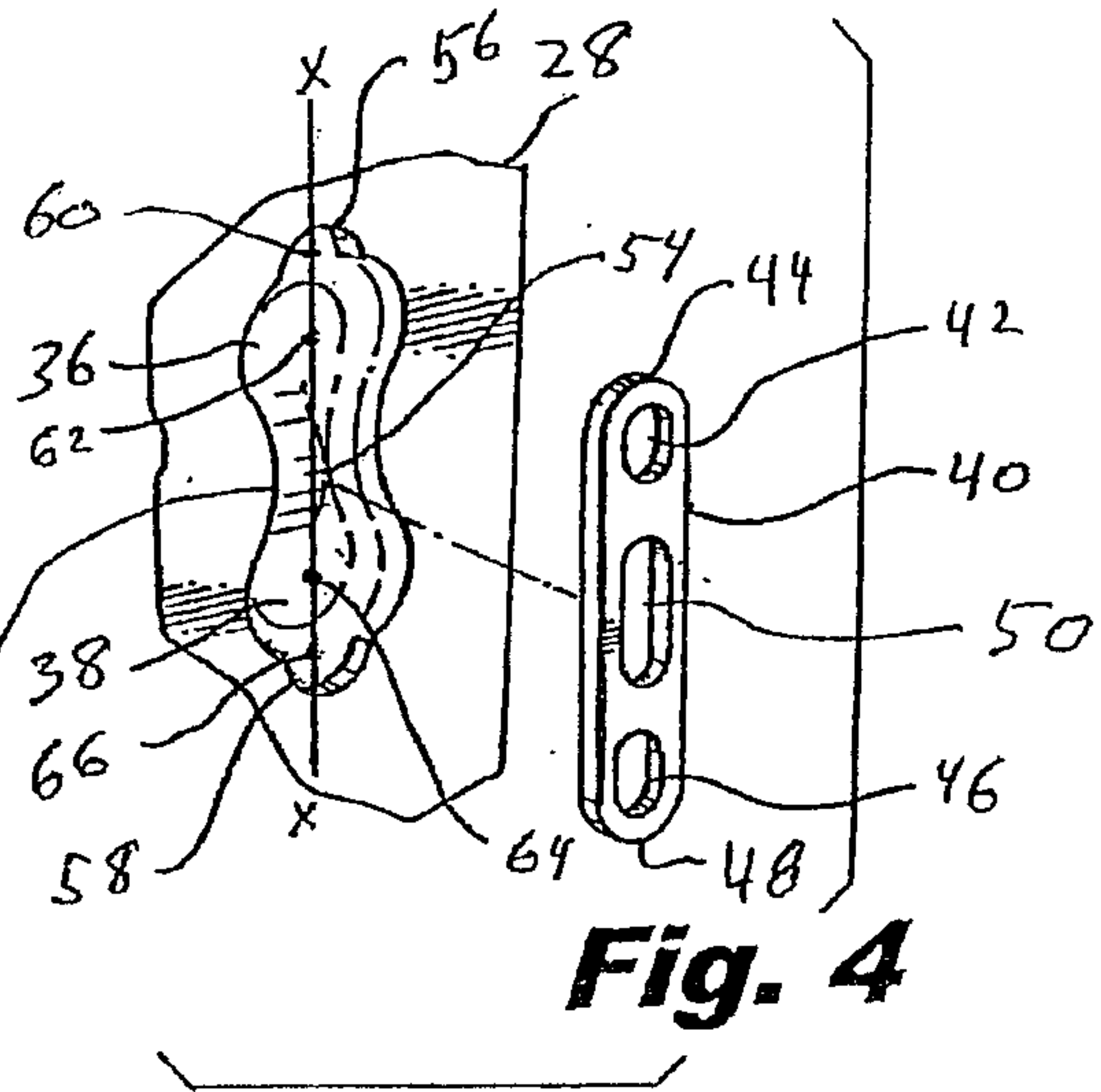
**Fig. 1**



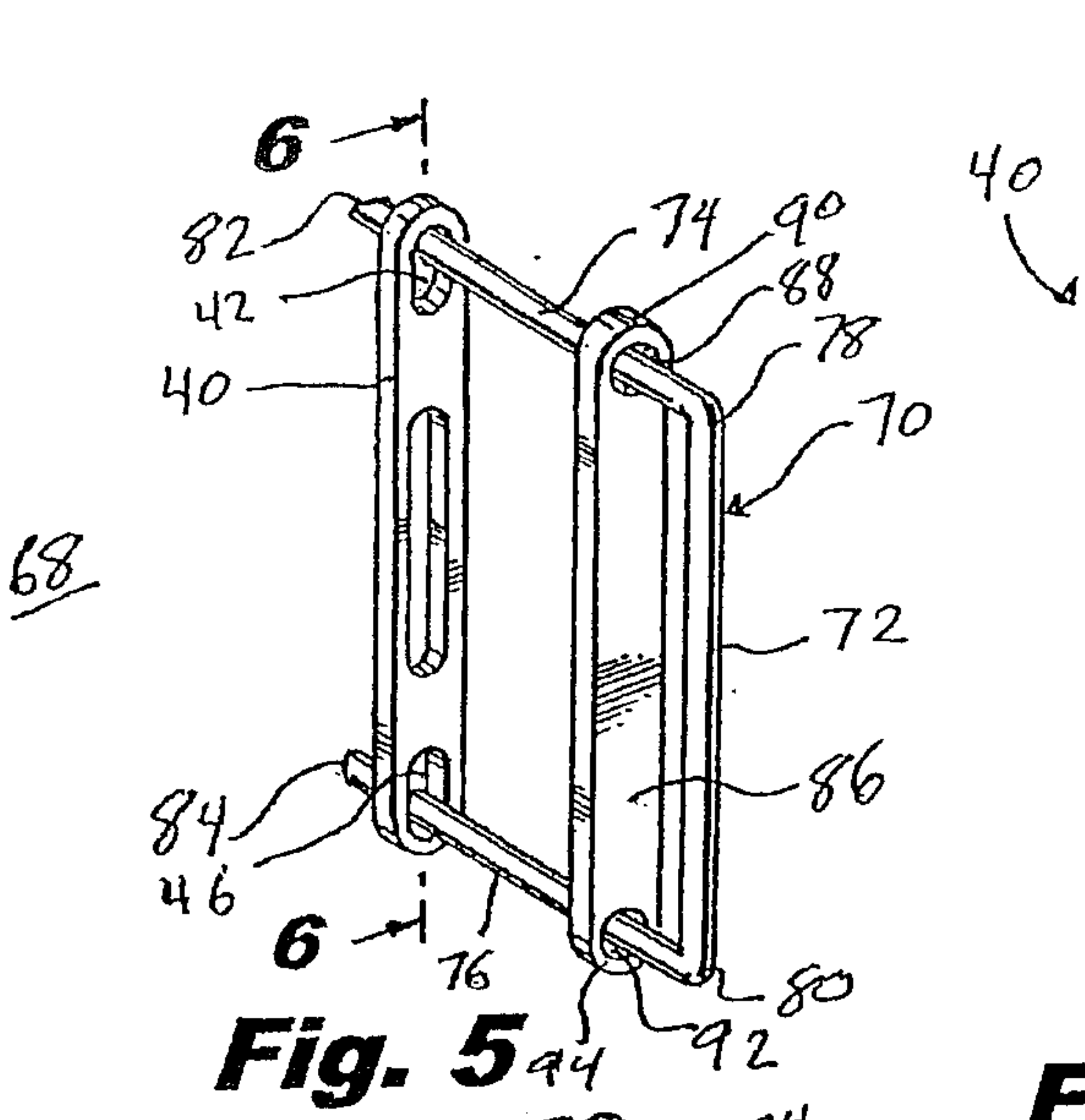
**Fig. 2**



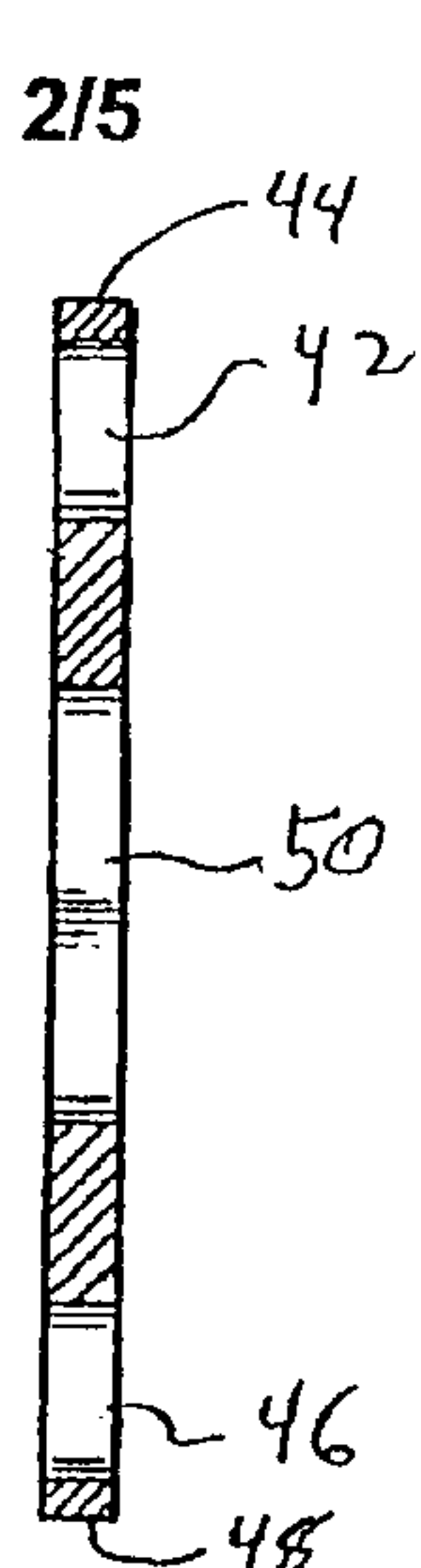
**Fig. 3**



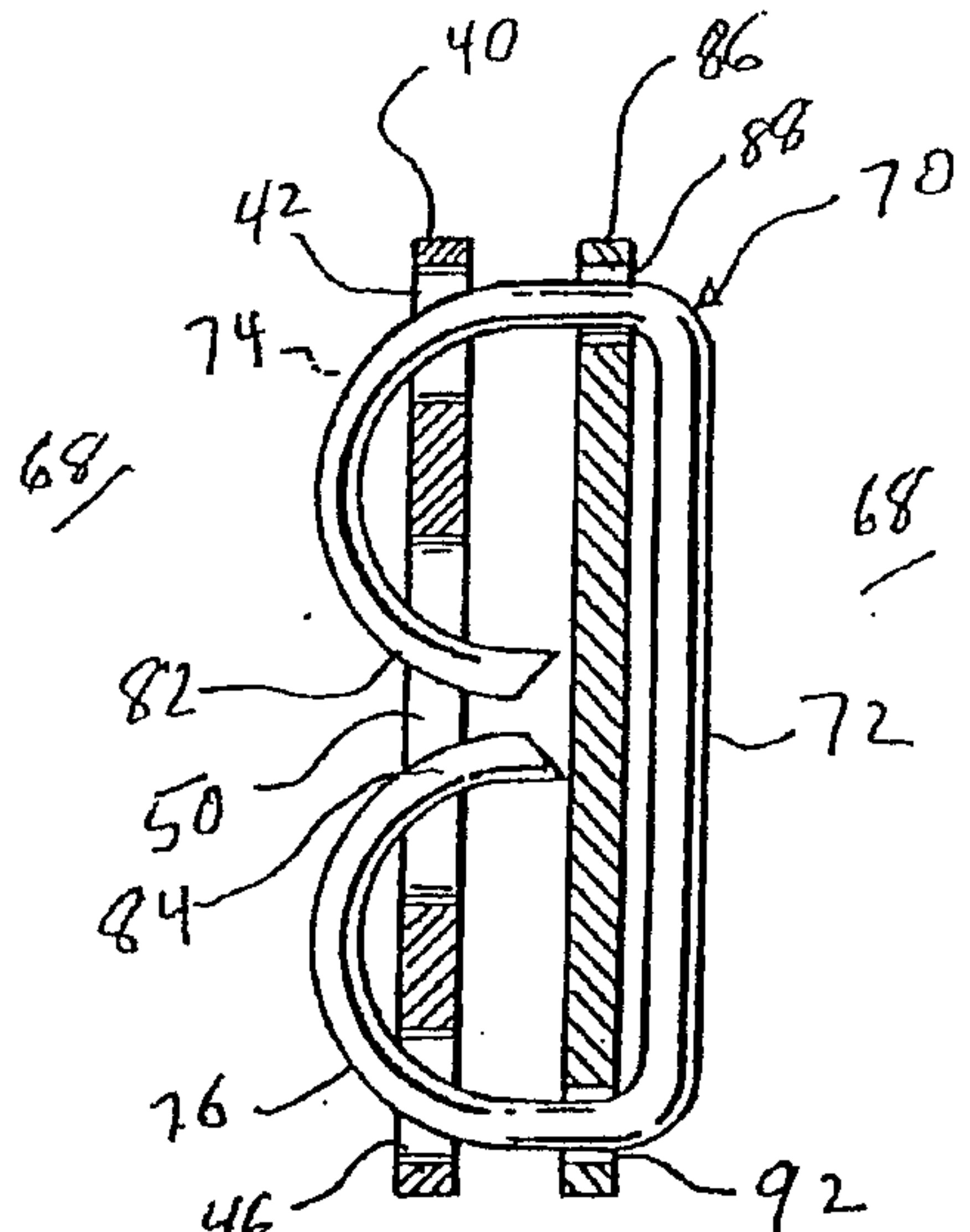
**Fig. 4**



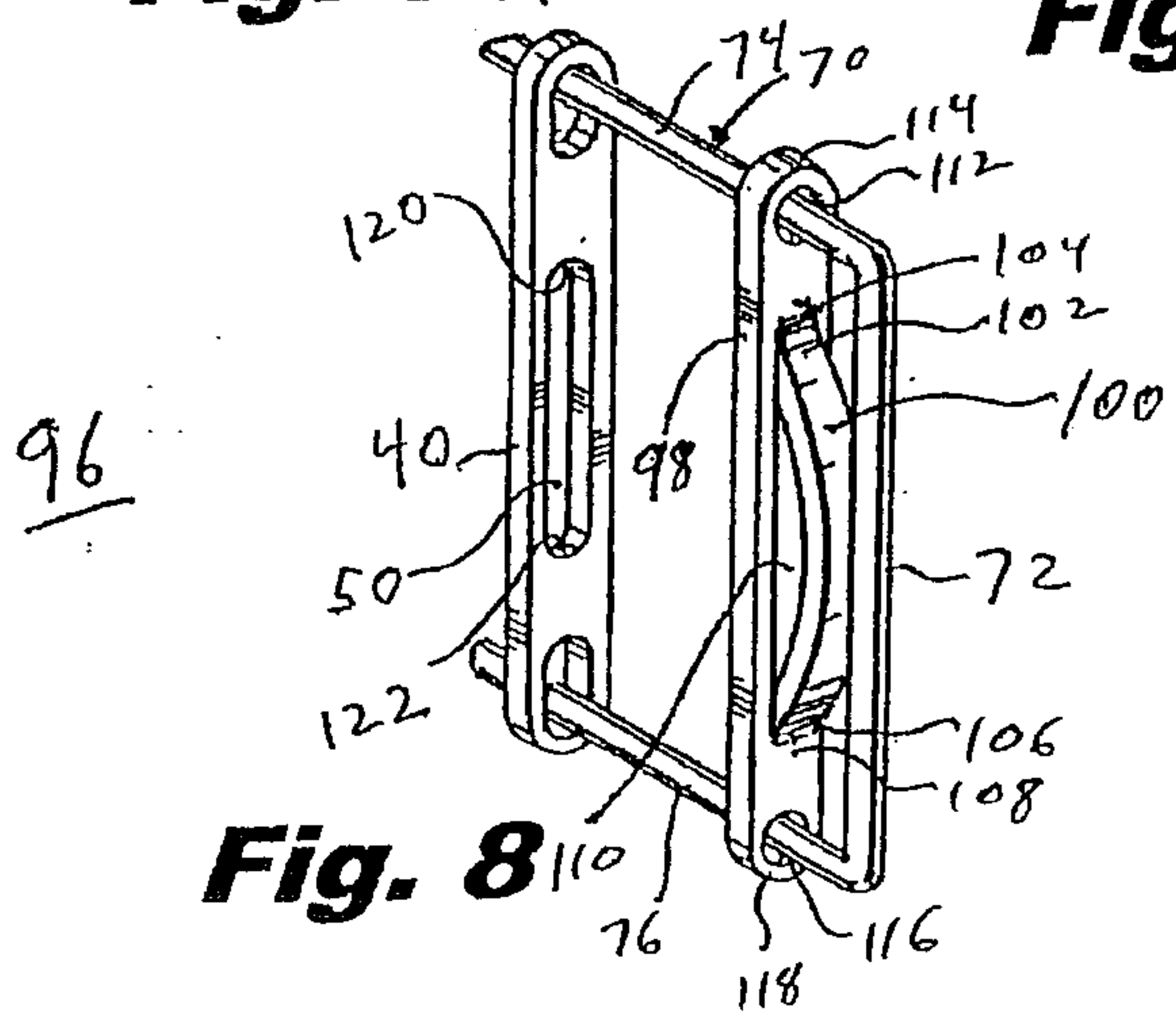
**Fig. 5**



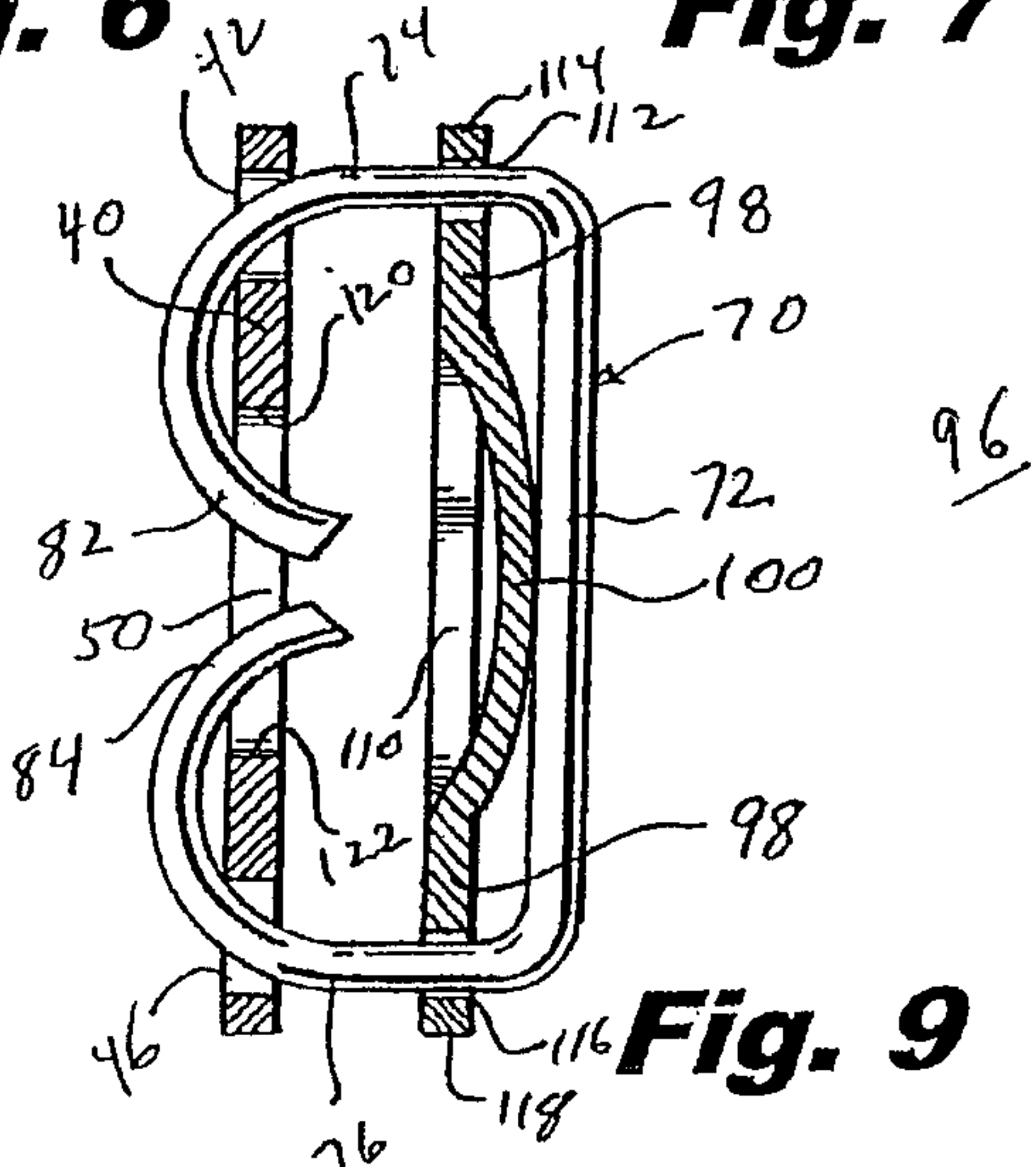
**Fig. 6**



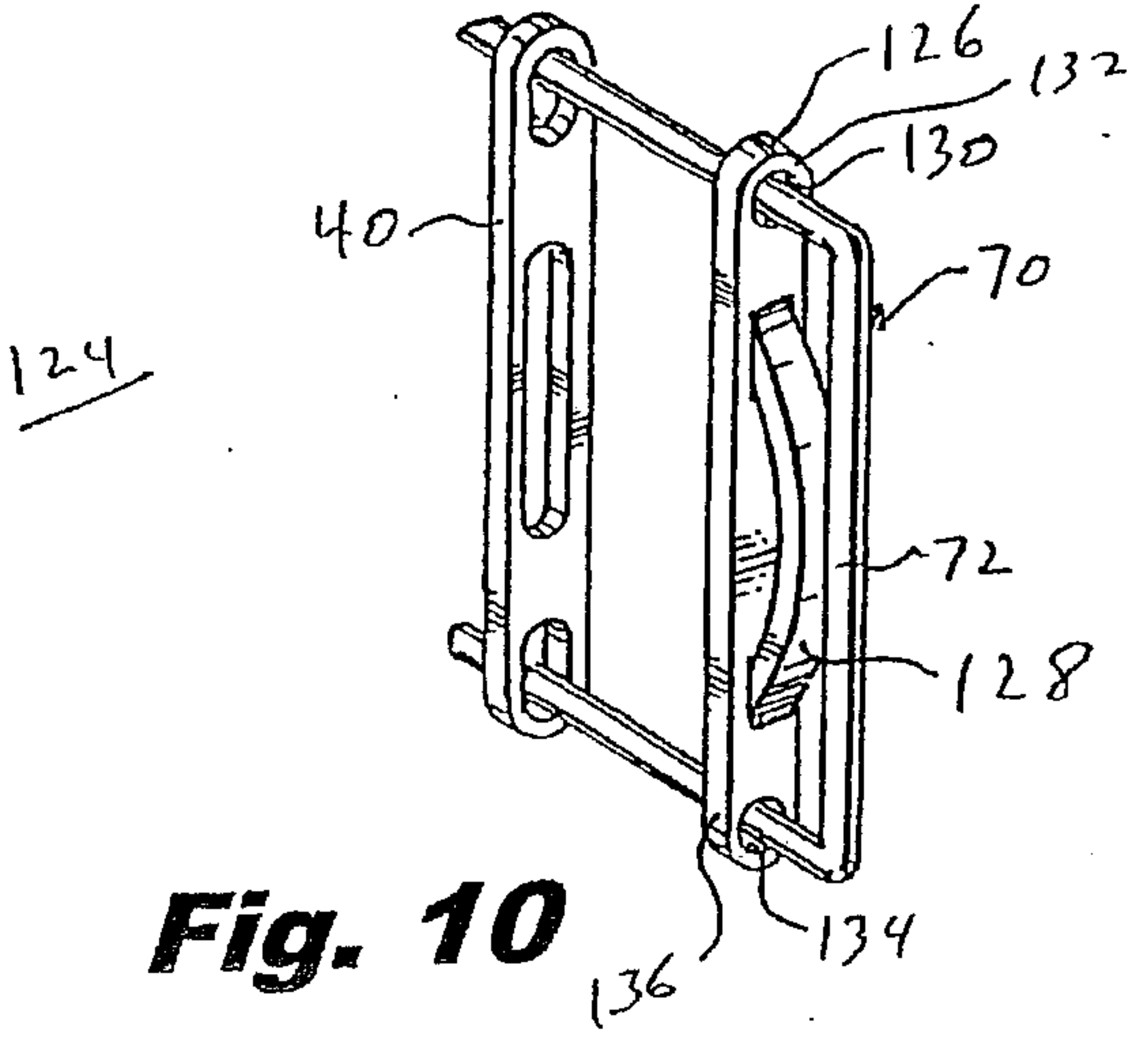
**Fig. 7**



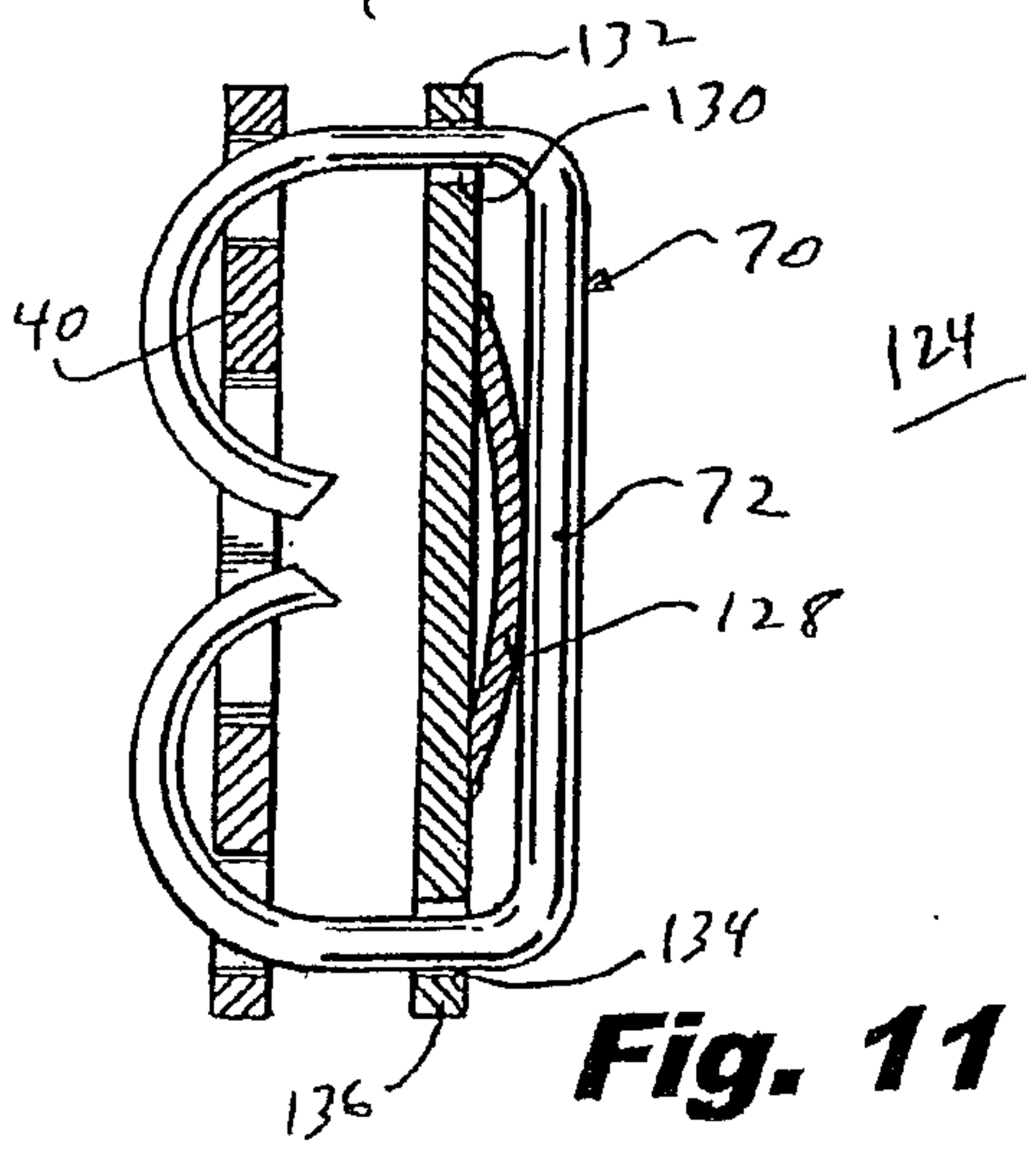
**Fig. 8**



**Fig. 9**

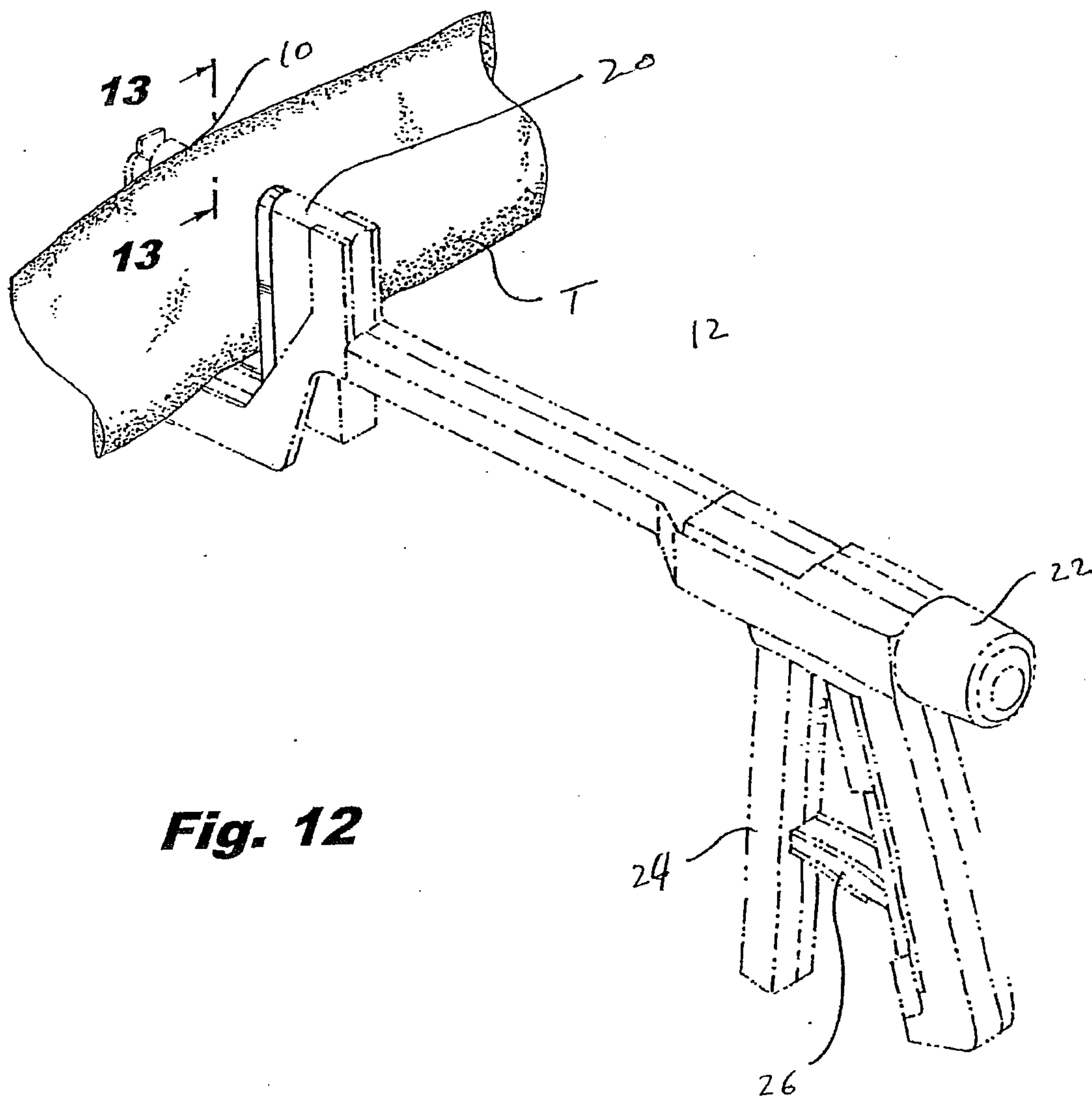


**Fig. 10**

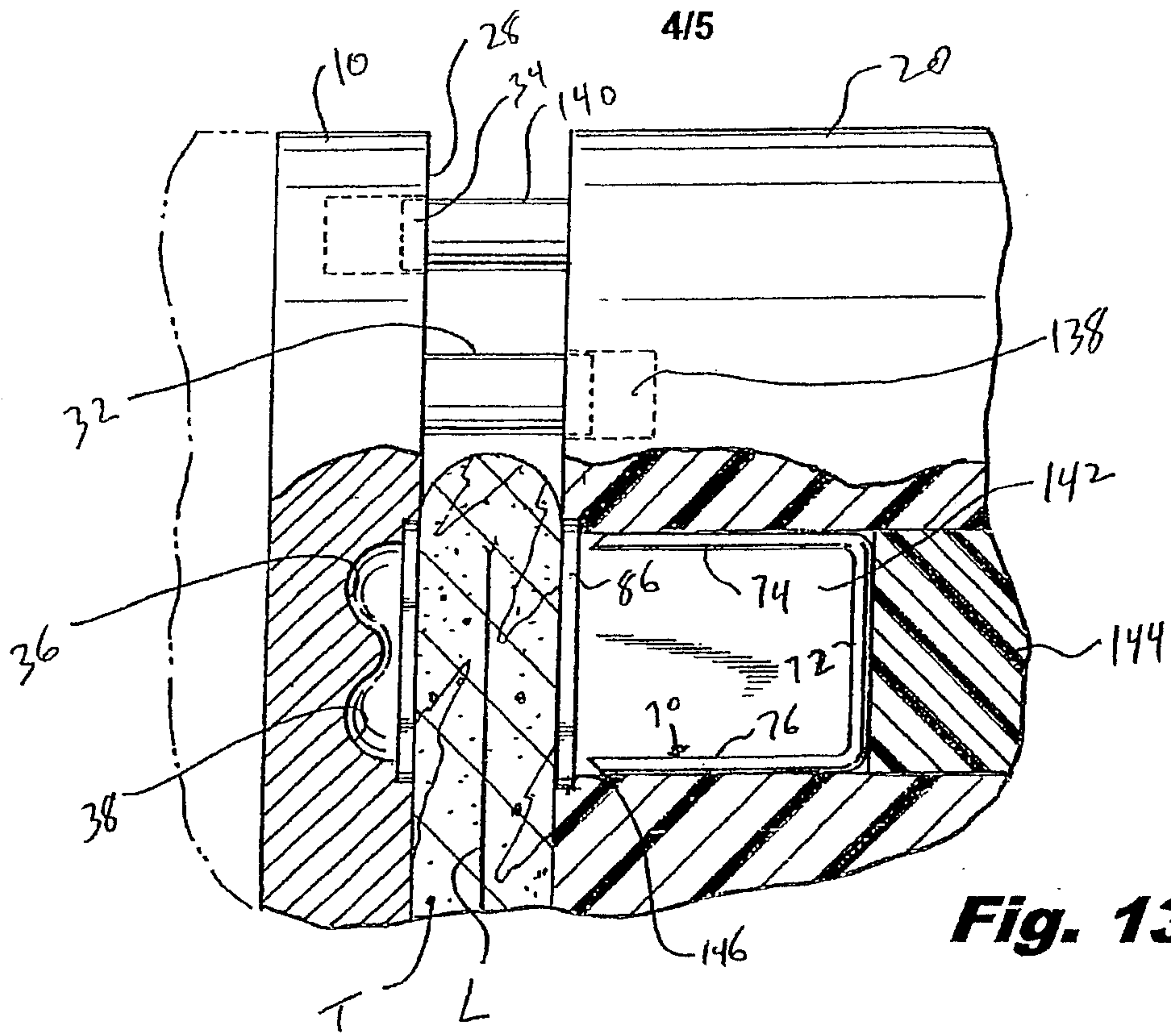


**Fig. 11**

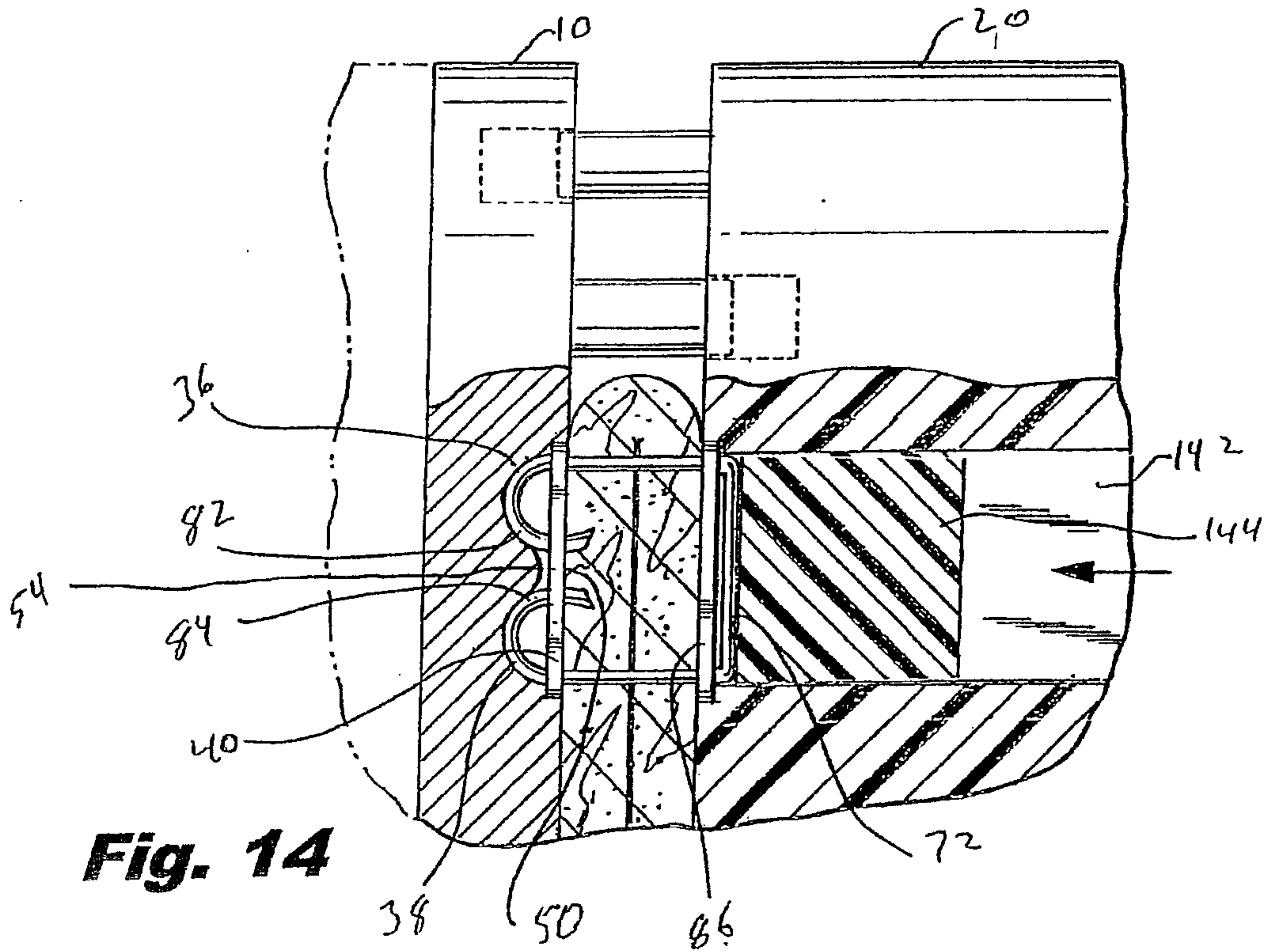
3/5



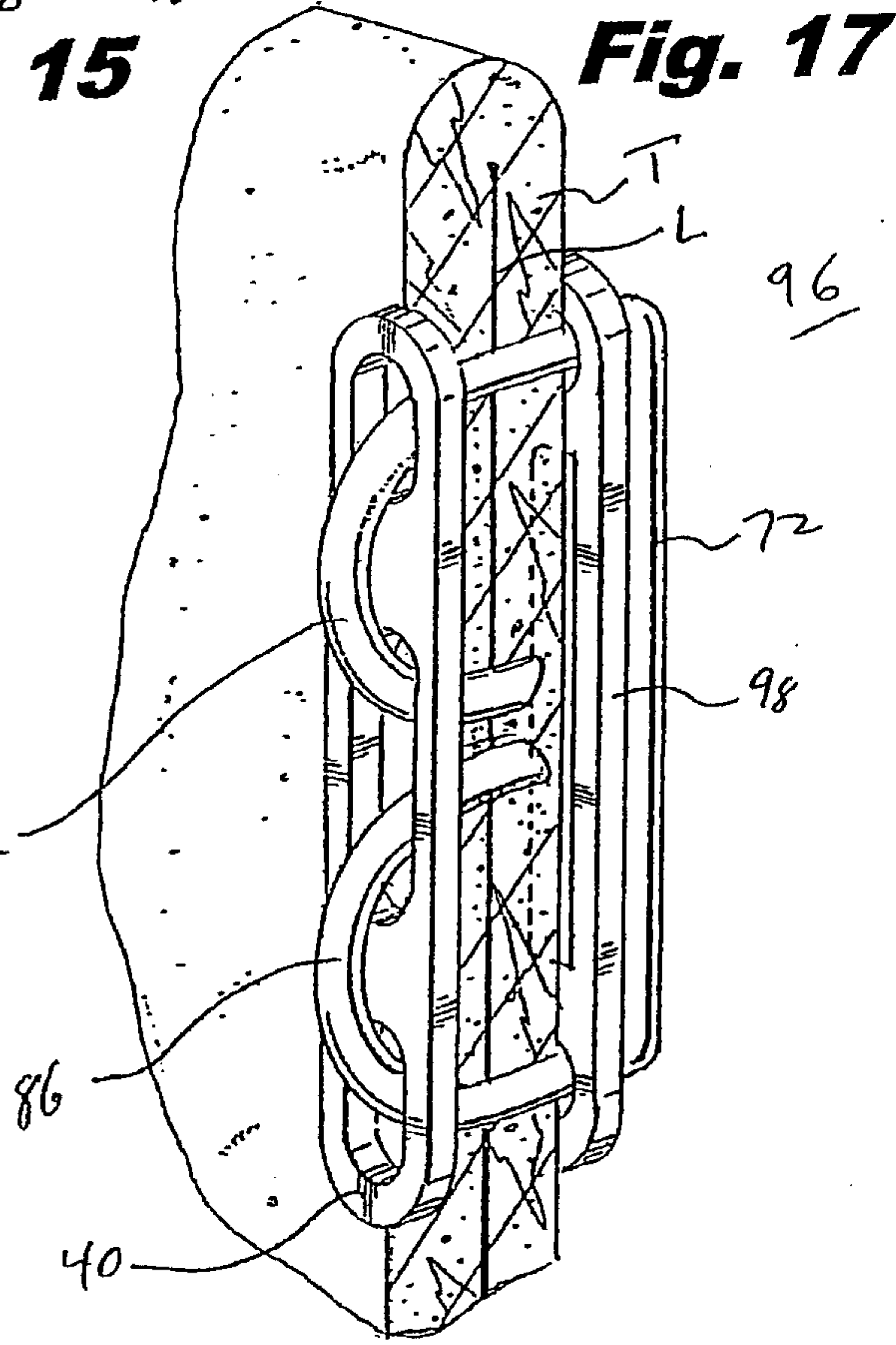
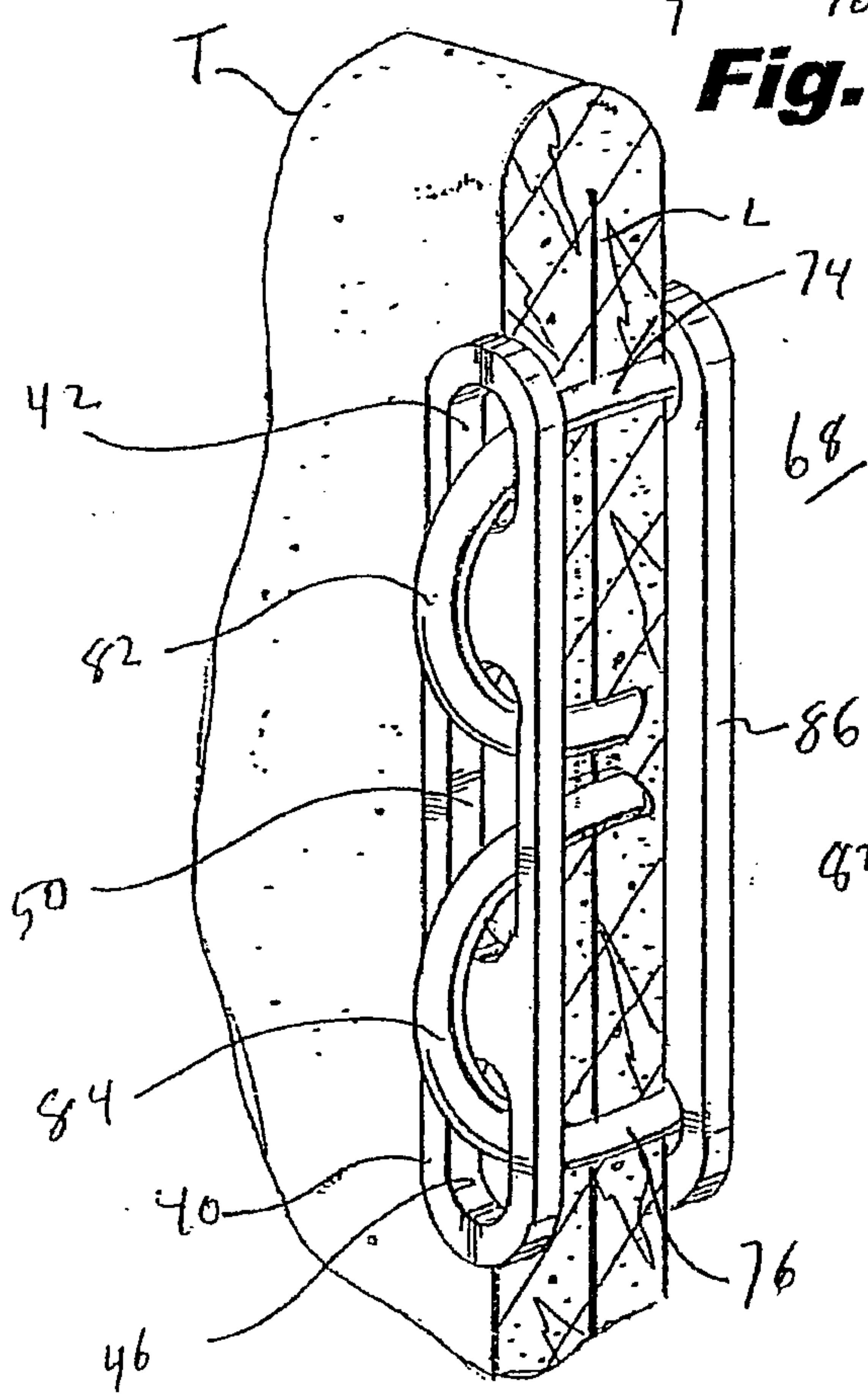
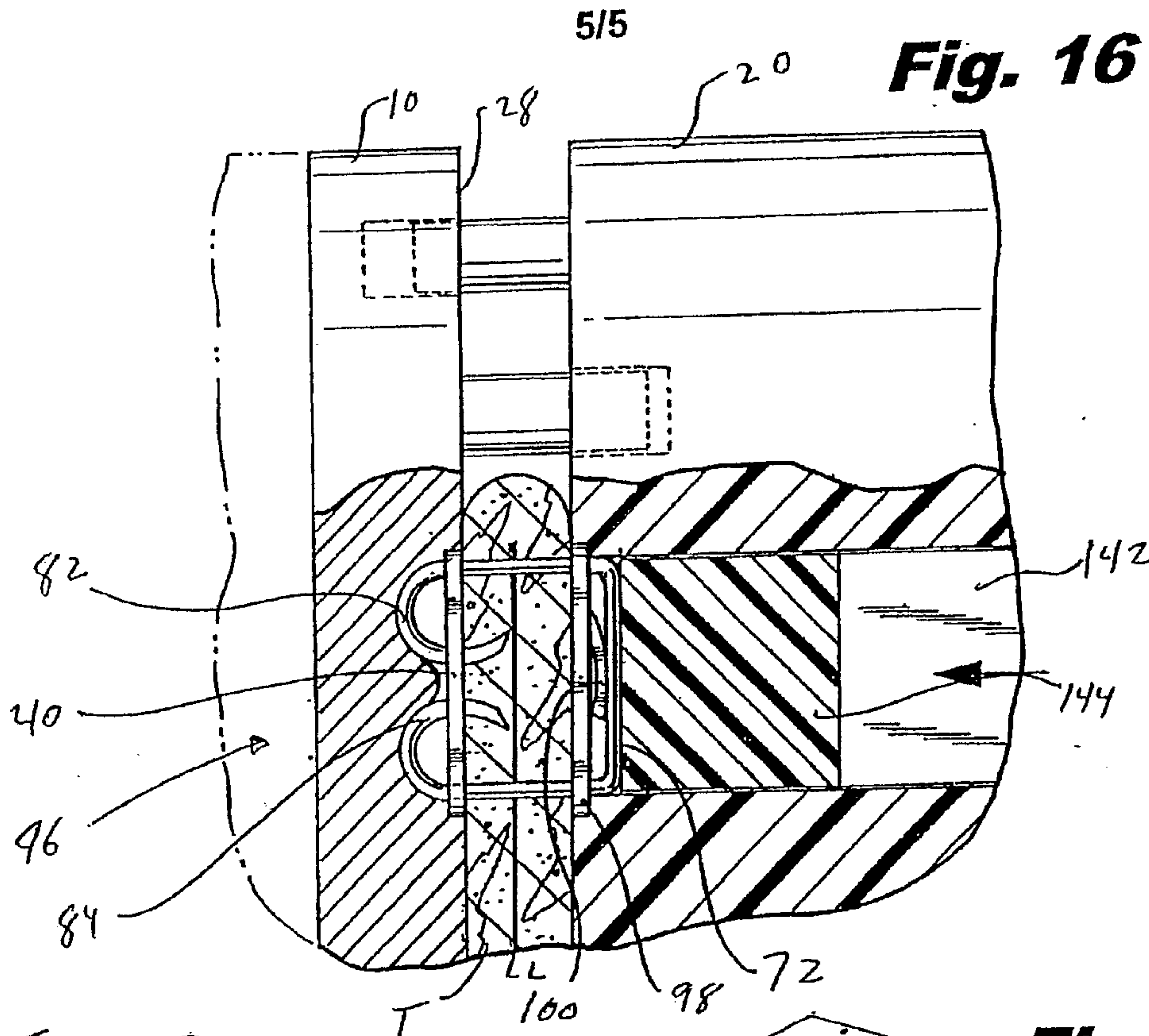
**Fig. 12**



**Fig. 13**



**Fig. 14**



96

