

June 26, 1962

C. L. LINKINHOKER
SPECIFIC GRAVITY SEPARATOR

3,040,892

Filed Aug. 17, 1959

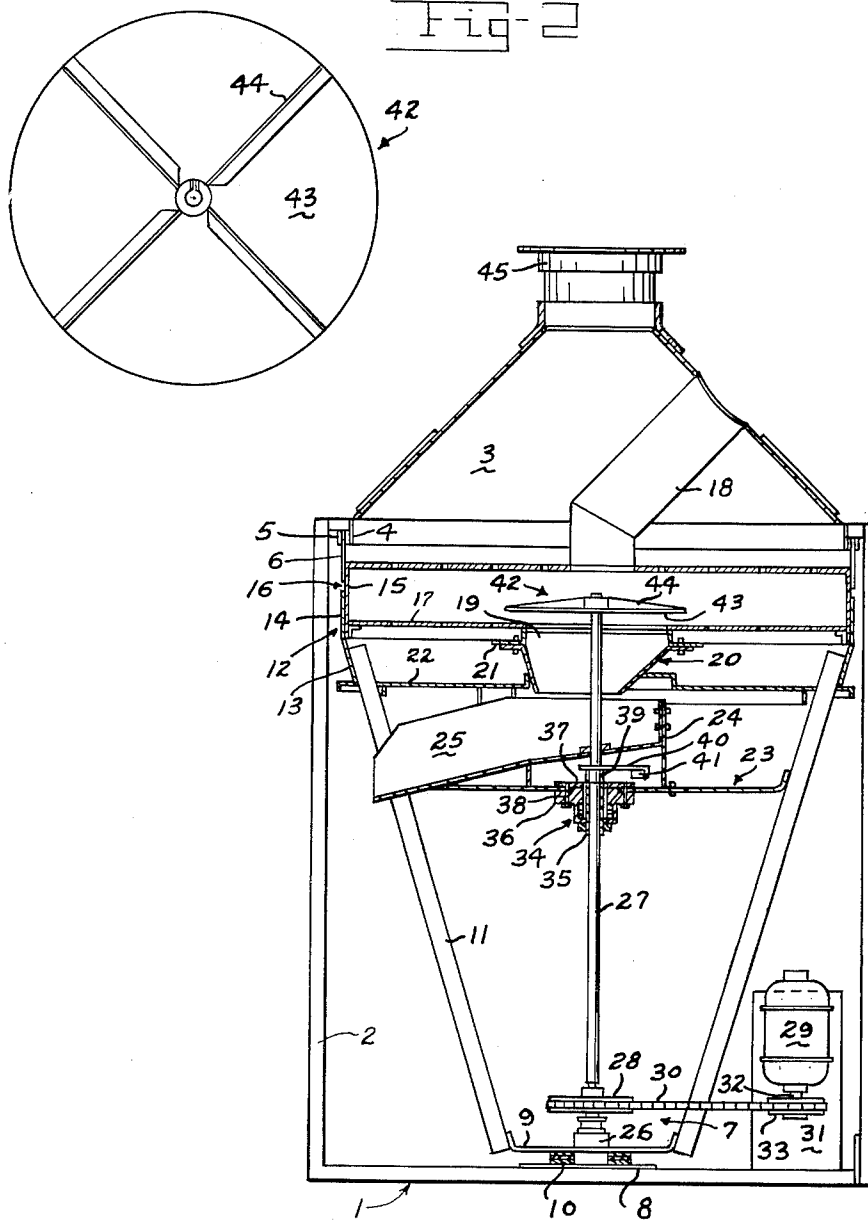

Fig-1

INVENTOR.
CHESTER L. LINKINHOKER
BY Tom Walker
ATTORNEY

1

3,040,892

SPECIFIC GRAVITY SEPARATOR

Chester L. Linkinhoker, Springfield, Ohio, assignor to The Bauer Bros. Co., Springfield, Ohio, a corporation of Ohio

Filed Aug. 17, 1959, Ser. No. 834,329

9 Claims. (Cl. 209-467)

This invention relates to grading and sorting apparatus and more particularly to a vibrator apparatus capable of automatically separating materials in a conglomerate body.

The present invention constitutes an advance and improvement over separators such as disclosed in United States Letters Patent No. 2,356,775 issued on August 29, 1944, to William H. Mechlin. It substantially expands the fields of application of such apparatus and renders it more efficient.

Prior separator apparatus has not been very successful in application to bulky materials of a fibrous character which have a tendency to entrap foreign particles in their tangled webs. For example, mineral wool or dry rag materials are quite bulky and frequently contain foreign materials such as small pieces of metal or rocklike substance entrapped therein. The conventional separator has proven quite inadequate for separating and sorting such materials.

The separator of the present invention will not only effectively operate on bulky fibrous bodies which inherently have foreign particles entrapped therein but also will be more efficient in grading and sorting the components of other types of conglomerate or intermixed bodies.

The invention will be particularly described herein in application to separating foreign particles from a body of fibrous material such as mineral wool. However, it should be understood that the invention is similarly and effectively applicable to such activities as separating commercial peanuts from leaves, vines, stems, roots and stones, cleaning peas and beans; separating grain from chaff and refuse; separating comminuted and pulverized materials; sorting parts and the like.

A primary object of the invention is to provide improvements in grading and sorting apparatus of a vibratory character whereby such apparatus may not only be economically fabricated but more efficient and satisfactory in use, more versatile in application, automatic in operation, of minimum complexity and unlikely to malfunction.

A further object of the invention is to provide grading and sorting apparatus capable of extracting foreign particles from a condition where they are entrapped in a conglomerate body.

Another object of the invention is to provide separator apparatus of a vibratory character having improved means for separating components of a conglomerate or intermixed body of materials in accordance with their specific gravity.

An additional object of the invention is to provide an improved separator of a vibratory character.

Another object of the invention is to provide a separator of a vibratory character having improved means for tearing conglomerate or intermixed bodies of materials apart to remove undesirable fractions thereof.

A further object of the invention is to provide a separator apparatus possessing the advantageous structural features, the inherent meritorious characteristics and the mode of operation herein mentioned.

With the above and other incidental objects in view as will more fully appear in the specification, the invention intended to be protected by Letters Patent consists of the features of construction, the parts and combinations thereof, and the mode of operation as hereinafter

2

described or illustrated in the accompanying drawings, or their equivalents.

Referring to the accompanying drawing wherein is shown one but obviously not necessarily the only form of embodiment of the invention,

FIG. 1 is a elevation view of separating and sorting apparatus in accordance with the invention; and

FIG. 2 is a plan view of the ribbed operating disc employed in the apparatus of FIG. 1.

Like parts are indicated by similar characters of reference throughout the several views.

The separator shown includes a base 1 having spaced vertical standards 2 about its periphery supporting a conical hood 3. The hood 3 has a dependent flange 4 confined by and spaced inwardly of the upper extremities of standards 2. A hood band 5 is fixed about the outer peripheral surface of a flange 4 to confine the upper extremity of a band of webbing 6. The webbing 6 depends from hood 3 within the standards 2 to define the opening from its lowermost extremity.

A vibrator plate assembly 7 is fixed centrally of the base 1. It includes a plate 8 fixed to the base. A dish shaped foot plate 9 is resiliently supported in vertically spaced relation to the base plate 8 by resilient step blocks or springs 10 to permit a rocking motion of the plate 9 relative the base 1. The sides of the plate 9 are directed upward in divergent fashion. Leg elements 11 are fixed to the outer side surfaces of plate 9 at their lower ends, spaced substantially equidistantly thereabout. The legs 11 uniformly diverge from their lower extremities. Fixed about and in containing relation to the upper extremities of legs 11 is a bracket 12 including a lower conically expanded portion 13 fixed to the legs and a vertically projected skirt 14 of uniform dimension upwardly of the legs.

The skirt 14 immediately contains and is fixed to the peripheral wall 15 of a riddle 16 which includes a perforate table 17 bridging the space confined by the upper extremities of legs 11. The vertical wall of the riddle projects upwardly of skirt 14 of the bracket supporting the riddle. The depending extremity of the webbing 6 is fixed to the outer peripheral surface of the upper projected portion of wall 15 to provide a flexible connection therebetween.

The hood 3 is thus disposed in overlying relation to and in communication with the table 17. A supply conduit 18 defining an opening to the hood 3 is angled inwardly to the center of the hood and then diverted to depend axially thereof and open over and in vertically spaced relation to the table 17. The table 17 has a central opening 19 aligned with the opening from conduit outlet. A downwardly convergent discharge cone 20 is fixed by an external flange 21 to depend from the undersurface of table 17 about the opening 19. A trash pan 22 is arranged below and in parallel spaced relation to the table 17. The pan 22 peripherally connects to the legs 11. The cone 20 depends through a central aperture in pan 22 and is immediately confined thereby.

An upwardly dished plate 23 arranged vertically below and generally parallel to pan 22 is peripherally connected to the divergent legs 11. The plate 23 has a vertical support bracket 24 projected upwardly to pan 22 to which is fixed a discharge spout 25. The spout 25 is open at its top to receive the discharge from cone 20.

A bearing assembly 26 is fixed on the center of the foot plate 9. The lower end of a vertical shaft 27 is mounted in the bearing assembly 26 to project upwardly through apertures in plate 23, pan 22, through cone 20 and table 17 to have its upper end terminate below and centrally of the outlet from the conduit 18.

A sheave 28 is fixed about the shaft 27 adjacent its lower end. Sheave 28 is driven from a motor 29 through

a belt 30. The motor 29 is mounted to a vertical base plate 31 fixed to the base 1. The motor has a vertically arranged drive shaft 32 mounting a sheave 33 through which it drives the belt 30.

The aperture in plate 23 through which shaft 27 extends is enlarged to accommodate a bearing housing 34. The housing 34 confines a sleeve bearing 35 which extends axially therethrough and immediately about the shaft 27. The housing 34 depends below the plate 23 and has an external flange 36 in abutting relation to its undersurface. An annular bearing support plate 37 seats to the upper surface of plate 23 to confine the sleeve bearing 35 to its upper end. Bolts 38 connect the flange 36 to the plate 37 through plate 23 and thereby fix the position of the bearing housing.

Fixed to and about shaft 27 immediately above plate 23 and bearing 35 is a collar 39 which has a connected radially projected arm 40. An eccentric weight 41 is fixed to the extremity of the arm 40 for purposes to be described.

Keyed to the upper end of the shaft 27 spaced above the table 17 is a distributor disc 42 consisting of a base plate 43 and spaced ribs 44 arranged radially of and projected vertically from the upper surface of plate 43.

A pipe 45 defines an opening in the upper end of hood 3 to form a vertical projection thereof.

It should be noted here that the table 17 is not perforated to provide a sieve but to permit air to be drawn therethrough by suitable suction means (not shown) connected to pipe 45 for purposes to be described.

An embodiment of the invention is thus provided which includes a table 17 adapted to receive conglomerate or intermixed bodies of materials through the supply conduit 18. Due to the eccentric weight connected to shaft 27 through the medium of the arm 40, drive of the shaft 27 will cause a progressive circular wobble or rocking movement of table 17 about a distant point adjacent the base 1. This is, of course, due to the nature of the resilient mount of the foot plate 9 relative the base plate 8. Thus, the legs 11, riddle 16 and other interconnected structure will have a uniform wobble corresponding to the nature and position of the eccentric weight 41 on the driven shaft 27. The distributor disc 42 will be rotating with the shaft 27 in the path of any material introduced to the riddle from the supply conduit 18.

Let us suppose that fine fibrous mineral wool is introduced through conduit 18 which has particles of metal, rock or the like entrapped therein, the purpose being to separate and sort the entrapped materials from the mineral wool. The separate components naturally have different specific gravity. As the mineral wool passes from the conduit 18 it will fall directly on the spinning, rocking distributor disc 42. It is noted that suction is maintained in the riddle area at this time by suction applied to the hood 3 through pipe 45 which induces a current of air to pass upward through the perforations in the table 17. As the wool hits the distributor disc, its ribs 44 tear the wool apart separating the fibers and freeing the entrapped particles of different substances. The rocking motion induced in the table 17 is of a vibratory character and is of greater range and angularity to the plane of the table at its peripheral margin. As the wool fibers and separated foreign particles are thrown from the disc 42, the suction induced air current applies a lift impulse to the relatively light wool fibers while the heavier foreign particles which have been extracted will fall to the surface of the table 17, thrown to its outer margin. The rocking tilting motion of the table applies successive tossing impulses to the heavier extracted foreign particles moving them inwardly of the margin of the table to be ejected through the opening 19 under the disc 42 from where they are channeled by cone 20 to discharge spout 25. The light wool fibers under the influence of suction are little effected by the vibration induced table motion and are forcibly displaced outward to the periphery of the riddle by the ribbed distributor disc,

being discharged thereby through openings in the wall thereof which are not shown. Suitable means are provided to aid in the efficient discharge of the light material but no detail thereof is described since this does not constitute any portion of the present invention. Only sufficient structure has been detailed herein as is pertinent to the invention. Other detail may be conventional and is revealed in illustrative fashion in the previously mentioned patent to Mechlin.

Thus, the invention provides a very effective initial separation of the components embodied in the rock wool introduced to tear all foreign particles from an entrapped condition whereby they may be separately exited from the separator based on their specific gravity. The illustrative application is but indicative of a general improvement in versatility and efficiency over the art as provided by the invention, irrespective of the make up of the conglomerate or intermixed bodies of materials which are introduced to the invention apparatus. It is also observed that a significant advantage of this invention is that the motor 29 is disposed in a position relatively isolated from the vibratory influence of the sorting and separating apparatus which it drives. Removal of the motor from the vibratory structure which it influences has proven not only to improve motor efficiency but also to increase its operating life and that of the associated vibratory structure per se, as well as rendering the latter more efficient. Maintenance requirements are minimized in the process.

From the above description it will be apparent that there is thus provided a device of the character described possessing the particular features of advantage before enumerated as desirable, but which obviously is susceptible of modification in its form, proportions, detail construction and arrangement of parts without departing from the principle involved or sacrificing any of its advantages.

While in order to comply with the statute the invention has been described in language more or less specific as to structural features, it is to be understood that the invention is not limited to the specific features shown, but that the means and construction herein disclosed comprise but one of several modes of putting the invention into effect, and the invention is therefore claimed in any of its forms or modifications within the legitimate and valid scope of the appended claims.

Having thus described my invention, I claim:

1. Separator apparatus including feed means, intercepting means in the path of said feed means rotatable to intercept and physically disassociate the components of intermixed and conglomerate bodies of materials delivered through said feed means, drive means for said intercepting means, and means connected with said drive means inducing a wobble motion of said intercepting means on rotation to cause it to have a tearing function as applied to fibrous type bodies.

2. Separator apparatus including feed means, intercepting means in the path of said feed means having projections in the direction of said feed means operative to intercept bodies of materials delivered from said feed means, means supporting said intercepting means for rotary and tilting motions, and means to spin and simultaneously induce a wobble of said intercepting means whereby the projections thereof will function to physically disassociate foreign bodies from materials delivered from said feed means.

3. Separator apparatus including gravity feed means, a ribbed separator plate in the path of discharge from said feed means, a sorting table in underlying spaced relation to said separator plate independent of said table, means for spinning said plate to cause it to disassociate and centrifugally dispense intermixed materials delivered from said gravity feed means to the marginal areas of said table, and means connected to said plate spinning means for vibrating said table in conjunction with the spinning of said plate to discharge disassociated materials in accordance with their specific gravity.

5

4. Separator apparatus including a vibratory platform having means connected therewith for inducing a wobbling thereof about a distant point, means for introducing conglomerate or intermixed bodies of materials to said platform, means independent of said platform for intercepting the bodies of materials as they are introduced to said platform including relatively projected portions extending in the direction from which the materials are introduced and means for inducing an eccentric spin of the intercepting means including said wobbling means.

5. Separator and sorting apparatus including a base, a frame mounted for rocking motion on said base, a table on said frame, shaft means independent of said base bearing in said frame and having an eccentric mass connected thereto, means independent of said frame connected to said shaft means for drive thereof, said eccentric mass inducing a wobble of the shaft means on drive thereof and a gyratory movement of said table, said drive means being mounted to said base free of the vibratory reaction induced by drive of said shaft means.

6. Separator apparatus comprising a base, a frame mounted for rocking movement on said base, shaft means in said frame and independent of said base having an eccentric weight connected thereto, a sorting table on said frame having a central aperture, said shaft means projecting through the aperture in said table, drive means on said base independent of said frame operative to drive, said shaft means inducing an eccentric spinning thereof and a consequent vibratory action on said table and a distributor disc fixed to said shaft means to overlie the aperture in said table in spaced relation thereto and operative to eccentrically spin with said shaft means, said disc including means operative in the spinning thereof to effect a tearing separating action on material delivered to said table.

7. Separator and sorting apparatus including a base, a frame resiliently mounted for rocking movement thereon, a perforated table fixed to said frame having a central aperture, a shaft bearing in said frame projected through the central aperture in said table and having a vibration inducing relation to said frame, gravity feed means over said table, drive means for said shaft on said base, said

6

drive means being independent of said frame, and means on said shaft above said table rotatable with said shaft, and having rib elements projected from one face in the direction of said feed means to intercept materials delivered to said table from said feed means and physically disassociate the components thereof.

8. Separator apparatus including, a base, a table having support means mounting it for rocking movement on said base, means for introducing conglomerate or intermixed bodies of materials to said table, intercepting means in overlying spaced relation to said table having means connected for eccentric drive thereof providing a tearing apart and centrifugal projection of components of the bodies of materials introduced to the marginal areas of said table.

9. Separator and sorting apparatus, including a base, a frame mounted for rocking motion on said base, a sorting table on said frame, shaft means bearing in said frame independent of said base, separating means connected for movement with said shaft means and associated with said sorting table, an eccentric mass connected with said shaft means for movement therewith, means independent of said frame connected to said shaft means for drive thereof, motor means mounted independent of said frame operatively connected to said drive means to produce a spinning of said shaft means and the separating means thereon associated with said table, said eccentric mass inducing a wobble of said shaft and separating means and a simultaneous rocking movement of said table in the process and said motor means being thereby free of the vibratory reaction induced by drive of said shaft means.

References Cited in the file of this patent

UNITED STATES PATENTS

35	951,964	McKinley	Mar. 15, 1910
	1,033,426	Lokken	July 23, 1912
	2,356,775	Mechlin	Aug. 29, 1944
	2,637,075	Rudy et al.	May 5, 1953
	2,822,090	Johnston	Feb. 4, 1958

FOREIGN PATENTS

40	184,870	Great Britain	Aug. 21, 1922
----	---------	---------------	---------------