



INTERNATIONAL APPLICATION PUBLISHED UNDER THE PATENT COOPERATION TREATY (PCT)

<p>(51) International Patent Classification ⁶ : A45C 5/00, 3/00, 13/10, 13/00</p>	<p>A1</p>	<p>(11) International Publication Number: WO 00/05990 (43) International Publication Date: 10 February 2000 (10.02.00)</p>
<p>(21) International Application Number: PCT/US99/16929 (22) International Filing Date: 26 July 1999 (26.07.99) (30) Priority Data: 60/094,431 28 July 1998 (28.07.98) US (71) Applicant (for all designated States except US): SAMSONITE CORPORATION [US/US]; 11200 East Forty-fifth Avenue, Denver, CO 80239 (US). (72) Inventor; and (75) Inventor/Applicant (for US only): SANTY, Dirk [BE/BE]; Moerestraat, 107, B-8680 Koekelare (BE). (74) Agent: O'CONNOR, Gregory, W.; Samsonite Corporation, 11200 East Forty-fifth Avenue, Denver, CO 80239 (US).</p>	<p>(81) Designated States: CA, CN, IN, JP, KR, SG, US, European patent (AT, BE, CH, CY, DE, DK, ES, FI, FR, GB, GR, IE, IT, LU, MC, NL, PT, SE). Published With international search report.</p>	

(54) Title: SOFTSIDE LUGGAGE CASE HAVING A SINGLE PERIPHERAL FRAME AND TWO SIDE-BY-SIDE COMPARTMENTS

(57) Abstract

A luggage case having a large pocket (40) carried by the main packing door (30). The pocket is formed by portions of the rail (20) releasably attached to the main case by a sinuous path zipper track (32), and a gusset (44) along the lower, self hinged portion (34) of the door. The resulting compartment protrudes into the interior of the case, and over at least one of the wheels (26), thus providing good organization within the case while helping to keep the case balanced on the wheels.

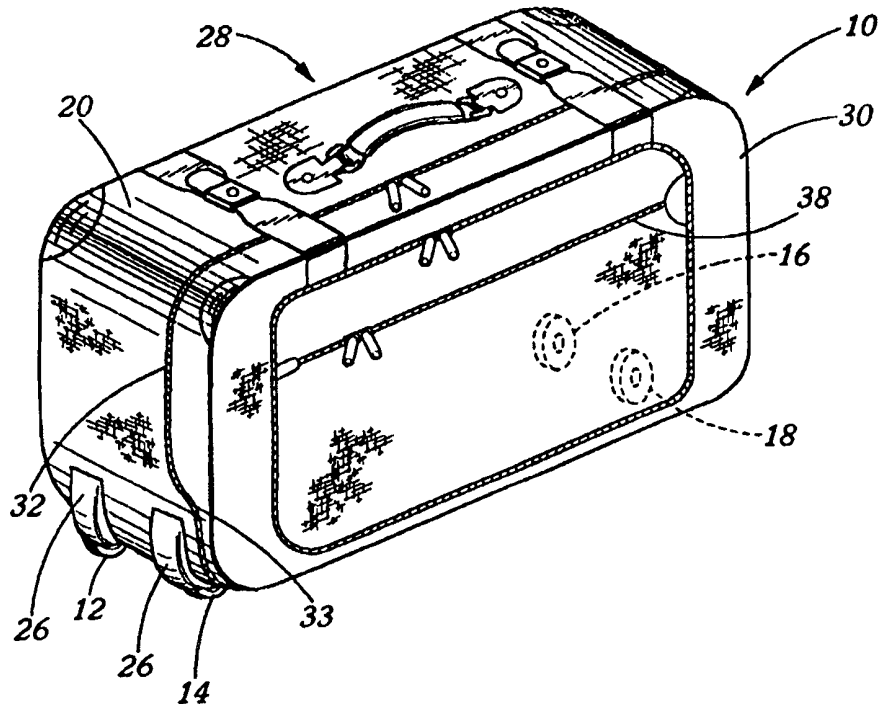

FOR THE PURPOSES OF INFORMATION ONLY

Codes used to identify States party to the PCT on the front pages of pamphlets publishing international applications under the PCT.

AL	Albania	ES	Spain	LS	Lesotho	SI	Slovenia
AM	Armenia	FI	Finland	LT	Lithuania	SK	Slovakia
AT	Austria	FR	France	LU	Luxembourg	SN	Senegal
AU	Australia	GA	Gabon	LV	Latvia	SZ	Swaziland
AZ	Azerbaijan	GB	United Kingdom	MC	Monaco	TD	Chad
BA	Bosnia and Herzegovina	GE	Georgia	MD	Republic of Moldova	TG	Togo
BB	Barbados	GH	Ghana	MG	Madagascar	TJ	Tajikistan
BE	Belgium	GN	Guinea	MK	The former Yugoslav Republic of Macedonia	TM	Turkmenistan
BF	Burkina Faso	GR	Greece			TR	Turkey
BG	Bulgaria	HU	Hungary	ML	Mali	TT	Trinidad and Tobago
BJ	Benin	IE	Ireland	MN	Mongolia	UA	Ukraine
BR	Brazil	IL	Israel	MR	Mauritania	UG	Uganda
BY	Belarus	IS	Iceland	MW	Malawi	US	United States of America
CA	Canada	IT	Italy	MX	Mexico	UZ	Uzbekistan
CF	Central African Republic	JP	Japan	NE	Niger	VN	Viet Nam
CG	Congo	KE	Kenya	NL	Netherlands	YU	Yugoslavia
CH	Switzerland	KG	Kyrgyzstan	NO	Norway	ZW	Zimbabwe
CI	Côte d'Ivoire	KP	Democratic People's Republic of Korea	NZ	New Zealand		
CM	Cameroon			PL	Poland		
CN	China	KR	Republic of Korea	PT	Portugal		
CU	Cuba	KZ	Kazakistan	RO	Romania		
CZ	Czech Republic	LC	Saint Lucia	RU	Russian Federation		
DE	Germany	LI	Liechtenstein	SD	Sudan		
DK	Denmark	LK	Sri Lanka	SE	Sweden		
EE	Estonia	LR	Liberia	SG	Singapore		

SOFTSIDE LUGGAGE CASE HAVING A SINGLE PERIPHERAL
FRAME AND TWO SIDE-BY-SIDE COMPARTMENTS

5

Background of the Invention

This invention relates to so-called pullman cases--luggage cases with two or more wheels arrayed along one elongated side. This particular style of pullman has a so-called drum construction, that is, a relatively rigid frame extending around the perimeter or rail, that is the four narrow sides of the case. Each of the opposite front and back sides are closed by a flexible textile membrane. One of these sides is usually releasably attached to the framed perimeter by a zipper or the like. Most such cases include a main packing compartment and at least one small zippered compartment, usually accessible from the outside of the zippered side or door. This zippered pocket on the door usually consists of nothing more than a narrow envelope of fabric receiving only the smallest amount of clothing and the like. Alternatively, such pullman cases have had a gusseted pocket that protrudes from 2 to 6 centimeters beyond the overall peripheral dimension of the case. This gives at least the illusion that the combination of this gusseted pocket and the main compartment has enhanced packing capacity.

20 There are many problems with these prior designs. The slit pocket in the door has very little packing space, leaving most of the packing space in one very large compartment that may be difficult for the traveler to organize. Also, once packed, the very deep main compartment presents a formidable obstacle to finding an article that has been packed. The pullman cases with the large gusseted pockets present a better

organization scheme. However, such gusseted compartments, since they project beyond one side of the framed rail, can result in an imbalance, perhaps causing the case to tip towards the packed and protruding pockets.

A third alternative case provides for a packing scheme that divides the main
5 packing compartment in two. This case uses two frames parallel with one another and separated by the zippered access that divides this main compartment. In this way, such a pullman luggage case would be divided approximately in half at a plane parallel to the rail and through the center of the rail, and each of the two resulting compartments would have a frame running around its periphery. Such a case could have wheels, one
10 or two, on each of these framed compartments. This generally would require a sturdy hinge connecting the two compartments so that the case would stand erect when the two compartments were zipped face to face.

Such a case, unfortunately, has several disadvantages. First, it tends to be heavier than a single frame case because of the extra frame. Secondly, the extra cost
15 and complexity of this more complex construction has made such a case less popular than the traditional lid-opening pullman case described previously.

Brief Description of the Invention

Accordingly, this invention comprises an overall luggage construction that utilizes
20 a single plastic or metal peripheral frame and an otherwise conventional drum construction to form the main body of the luggage case. However, instead of the usual flat lid zipped on to one edge of the peripheral rail, the subject invention provides a

case that zips to the main body along a sinuous path or on an angled connecting plane. The zippered attachment releasably attaches the top and two side edges of the lid and the lid is self-hinged to the main body of the case along or near the intersection of this lid face and the bottom side of the rail where wheels or glides are attached. The zipper

5 path runs from this self-hinged edge and curves towards a central dividing plane of the rail to define a second compartment (in addition to the main compartment to which it is releasably attached) having a substantial depth. Thus, the lid comprises the one side face and three walls, the walls spanning the ends and top of the lid. The depth of these

10 walls of the lid compartment comprises ideally one-third of the total width (or depth) of the overall luggage case. The fourth wall of the case can be closed by a textile gusset usually made of lining material (in contrast with the case body material which forms the front face or lid and the three side walls mentioned above). A light, stiff material, such as a polyethylene sheet, holds the shape of these three walls and the gusset formed by

15 the lining material. These stiffening plastic layers, however, do not constitute a structural frame. When the lid is closed, this fourth gusset wall rests on the bottom board of the rail, and is thus inboard of, or at least positioned over, one set of wheels in the case of a pullman case.

Detailed Description of the Preferred Embodiment

20 Figure 1 shows a perspective view of a pullman case 10 in accordance with the instant invention. Shown here are the fixed axis wheels 12 and 14 at the lower rear corner of the luggage case. Preferably another pair of wheels, such as caster wheels

16, 18 of a known construction (shown by dashed lines in Figure 1, and from the front end of the case in Figure 4), are positioned at the forward lower corners of the case so that the case can be pulled on all four wheels, or alternatively, the front corner of the case can be lifted and the suitcase wheeled on just the two back wheels as shown.

5 The rail 20 extends around the rest of the periphery of the case, having a frame 22 (see Figure 2) that structurally stabilizes this rail and thus the rest of the case. The bottom of the case is made structurally stable by an interior bottom board 24 (Figure 2) and a molded bezel 26 that holds and positions each pair of wheels (see Figures 3 and 4). The back wall 40 is attached to the rail along one edge to form a main packing

10 compartment. The main packing door 30 is attached to the rail by a main access slide fastener or zipper 32. The zipper track of the main zipper 32 is sewn, using conventional means, along a path that divides the rail and defines about one-third of the total width of the rail around three of the four sides of the rail. Note that the zipper track curves away from this one-third/two-thirds path to intersect the edge of the lid face of

15 the case at the intersection 34 of the bottom side of the rail and the face of the lid 30. In this embodiment, the lid also includes an additional slit pocket accessed from the outside by conventional zipper 38. While the zipper track 32 is shown to take a sinuous or curving path at 33, this path could also be generally straight in this region 33, forming a diagonal line between the self hinging portion 34 and the straight path nearer the

20 center line of the rail. In this way, a substantial portion of the rail, at least along the top and side portions, forms substantial portions of the main packing door.

Figures 5 and 6 show this main access zipper in the open condition. The two-

thirds/one-third split is clearly shown, as is the construction of the gusseted compartment wall within the case. The single narrow frame 22 of conventional rolled steel or extruded extends along the center line of the rail 20 and around the inside of the rail 20 and the bottom of the case includes a wider board 24 that extends from the
5 intersection of the front face of the case to the rear face of the case.

Figure 3 shows a detail of the hinged portion of the main packing door. As can be seen, the zipper track 32 is at the intersection of each of these zipper tracks. The interior textile gusset wraps around the corner and has an interior wall attached around to its inner face. This inner wall has its own zipper access as well.

10 Figure 5 shows an interior view of the same corner shown in Figure 4. Clearly seen in this view is the peripheral frame passing around the inside of the rail. The bottom board extends underneath this frame as is conventional, all the way out to the terminal ends of the main access zipper.

Figure 6 shows a detail from the rear side of the case showing the depth of the
15 interior rail and its relationship to the curving zipper track. A stiffening material, such as a conventional thin sheet 46 of polyethylene, is positioned within the otherwise flaccid cloth gusset 44 that the full volume of this door compartment can be easily utilized by the traveler. The path of the most interior corner 45 of the gusset 44 is shown by the dashed arrow line. Note how the volume defined by the second
20 compartment 40 is thus positioned over the wheel 14, and the traveler's goods in the compartment 40 would thus be supported by the wheels 14 thereunder. This construction permits easy and organized packing, but does not encourage over packing

and unbalancing of the case. In contrast with other pullman and even upright style cases which offer one or a series of gusseted auxiliary packing pockets protruding from the side of the case, the instant invention keeps such potentially unbalanced loads to a minimum, and does this with only a single perimeter frame such as frame 22 for
5 structural stability.

Figure 4 clearly shows the unique sinuous path which the main access zipper forms at each of its terminal ends. This sinuous path is most striking at the front and rear corners of the main access door where it curves through a path that first is parallel to the front and rear faces of the case, then bends smoothly towards the front face,
10 continues at an acute angle and then curves again as it approaches the front face to be parallel to the front face, terminating at the self-hinged portion as mentioned above.

Figure 3 shows this sinuous path continuing around the rounded corner that characterizes the drum construction of the basic case, and terminates where the bottom board flattens out.

15 While the invention is described in terms of a pullman case execution, it should be understood that this concept could be applied to roll-on cabin luggage, so-called upright luggage (where the main access is in the vertical direction), soft business cases, and beauty cases.

Claims:

1. An improved luggage case having a rail, two or more wheels mounted along a bottom side of the rail, a relatively rigid frame extending around the rail, front and back side walls attached to the rail at their perimeters, the side walls being closed by a flexible textile panel, and a slide fastener to releasably attach the front side wall to the rail whereby the front side wall forming a door for access to a main packing compartment accessible therethrough, the improvement comprising the slide fastener extends along a path which divides the rail generally along its length and which releasably attaches top and two side edges of the lid to the rest of the case, whereby substantial portions of the rail remain affixed to the front side wall, whereby the substantial portions form part of the door along the top and along the two side edges of the front side wall, the lid further including a self hinge portion at the intersection of the front side wall and the bottom side of the rail, and the path of the slide fastener angles towards the self hinge portion from the two side edges, whereby the lid hinges open and closed along the self hinge portion when the slide fastener is open, said lid further including a textile panel attached along the slide fastener and at the self hinge portion to define, in conjunction with the front side wall and the portions of the rail affixed to the top and side edges of the front side wall, a second compartment within the case having a substantial depth.

20

2. An improved luggage case according to Claim 1 wherein the portions of the rail divided by the slide fastener and affixed to the top and side edges of the front side wall

have a depth dimension of about one-third of the total width of the rail of the overall luggage case.

3. An improved luggage case according to Claim 1 wherein the textile panel is
5 made of lining material.
4. An improved luggage case according to Claim 3 wherein the three walls and the textile panel of the second compartment include a layer of a light, stiff material, such as a polyethylene sheet, for holding the shape of these three walls and the gusset.
10
5. An improved luggage case according to Claim 1 when the lid is closed, the gusset rests on the rail, and is positioned over at least one of the of wheels, whereby the weight of items in the second compartment is generally over and born by said wheel when the luggage case is running on the wheels.

15

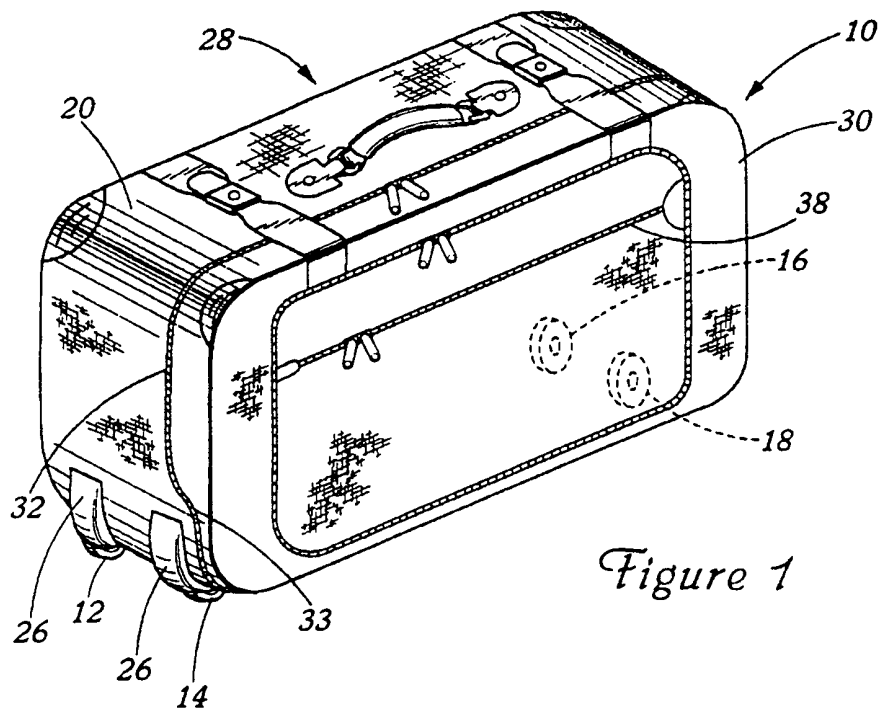

Figure 1

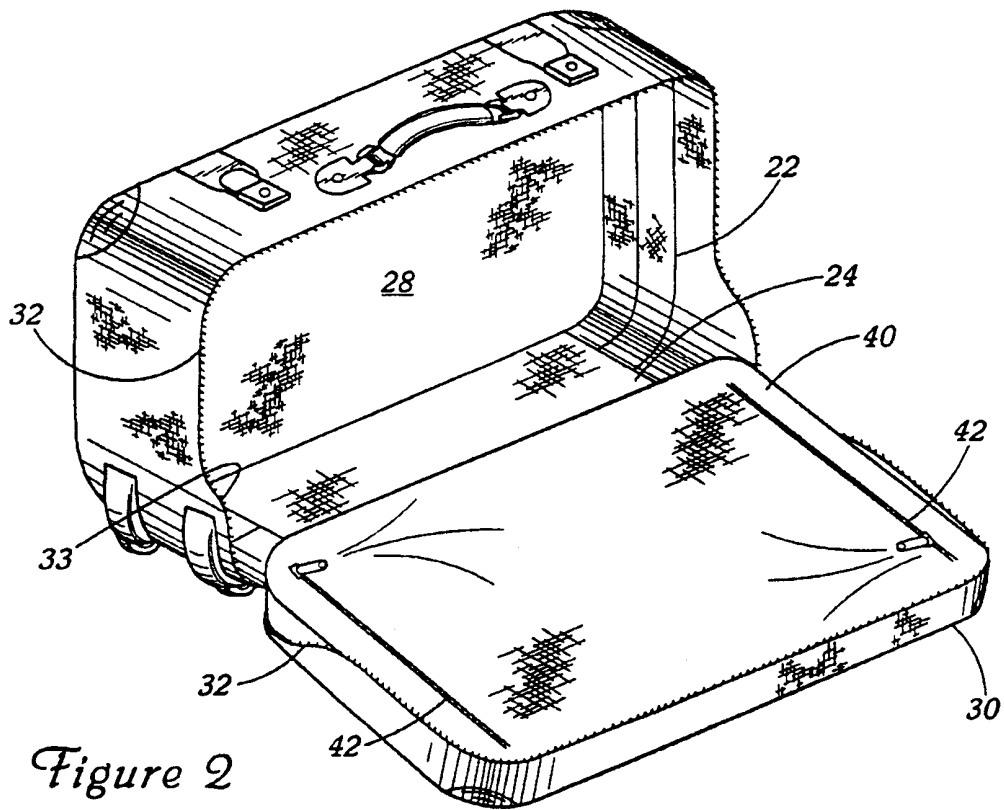

Figure 2

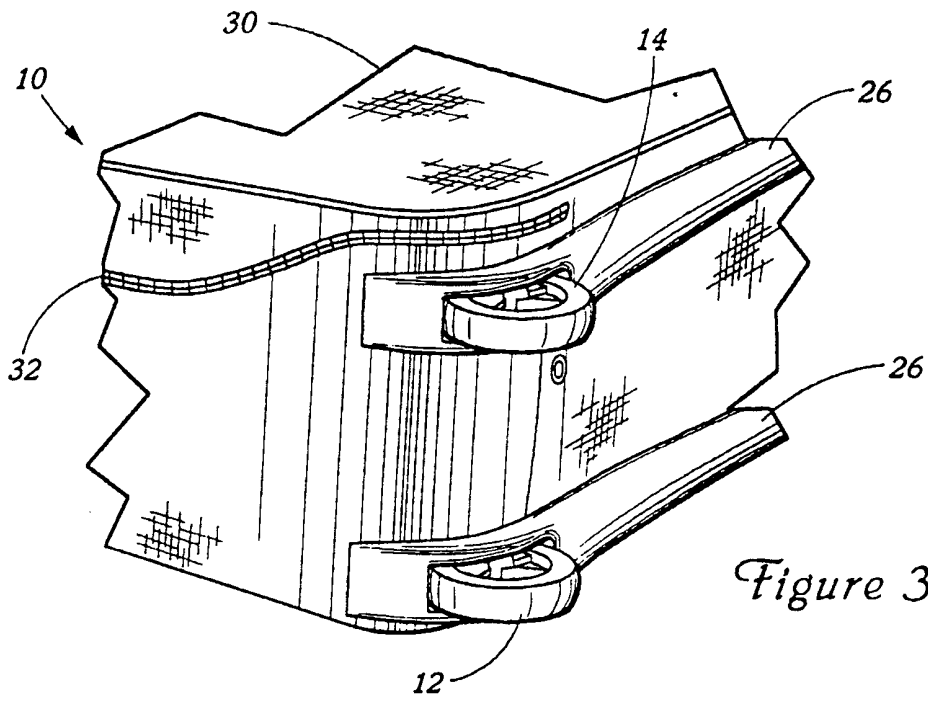

Figure 3

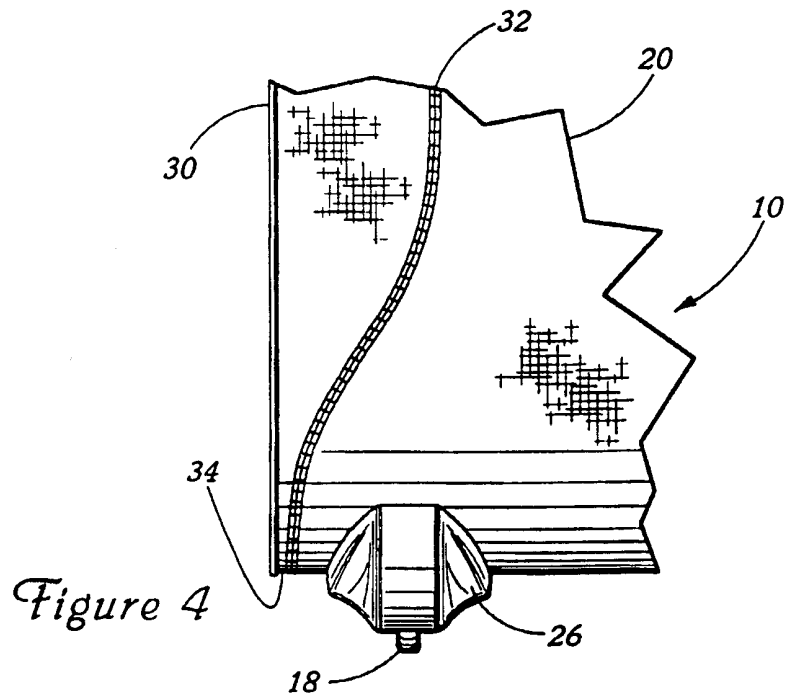

Figure 4

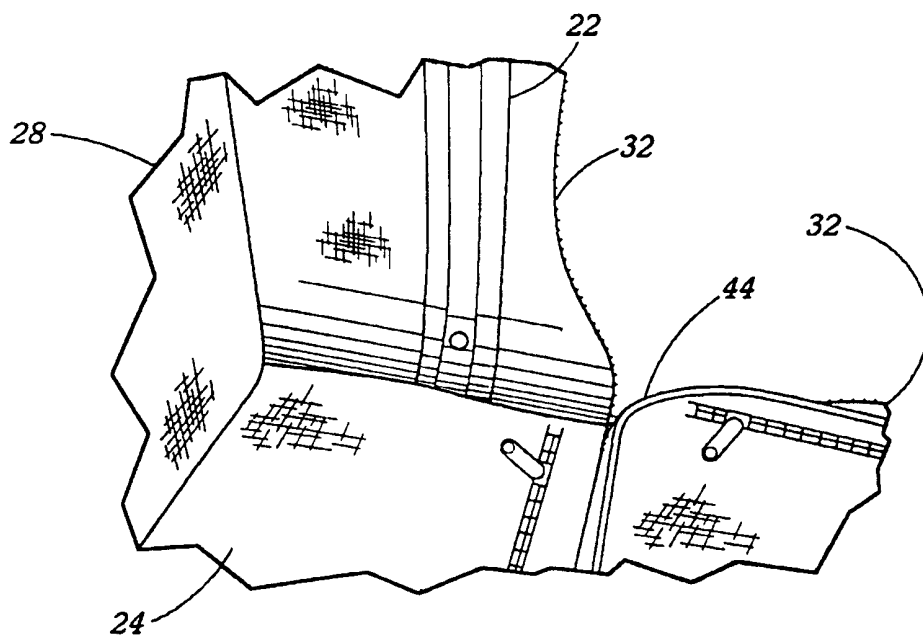

Figure 5

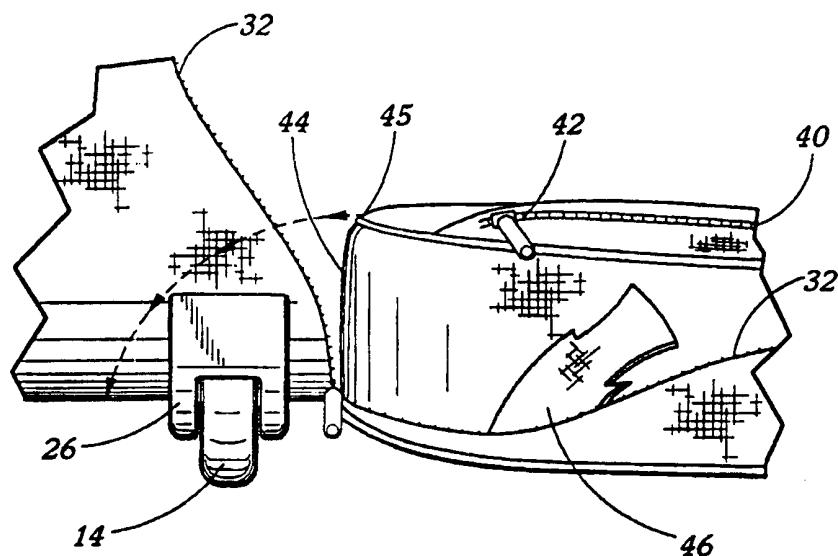

Figure 6

INTERNATIONAL SEARCH REPORT

International application No.
PCT/US99/16929

A. CLASSIFICATION OF SUBJECT MATTER

IPC(6) :A45C/5/00, 3/00, 13/10, 13/00

US CL :190/18A, 111, 903, 110, 119, 125

According to International Patent Classification (IPC) or to both national classification and IPC

B. FIELDS SEARCHED

Minimum documentation searched (classification system followed by classification symbols)

U.S. : 190/18A, 111, 903, 110, 119, 125

Documentation searched other than minimum documentation to the extent that such documents are included in the fields searched

Electronic data base consulted during the international search (name of data base and, where practicable, search terms used)

C. DOCUMENTS CONSIDERED TO BE RELEVANT

Category*	Citation of document, with indication, where appropriate, of the relevant passages	Relevant to claim No.
X	US 4,589,530 A (SHER) 20 May 1986, see the entire document.	1, 2
Y	US 2,716,473 A (DROUTMAN) 30 August 1955, see the entire document	3, 4
A	US 2,362,807 A (DRESNER) 14 November 1944, see the entire document	5
A	US 2,669,273 A (KEIRSEY) 16 February 1954, see figures	1-5
Y	US 2,282,409 A (LOWE) 12 May 1942, see the entire document	3-4
Y	GB 621,924 A (LEWIS) April 1949, see the entire document	1

Further documents are listed in the continuation of Box C. See patent family annex.

* Special categories of cited documents:	"T" later document published after the international filing date or priority date and not in conflict with the application but cited to understand the principle or theory underlying the invention
"A" document defining the general state of the art which is not considered to be of particular relevance	"X" document of particular relevance; the claimed invention cannot be considered novel or cannot be considered to involve an inventive step when the document is taken alone
"E" earlier document published on or after the international filing date	"Y" document of particular relevance; the claimed invention cannot be considered to involve an inventive step when the document is combined with one or more other such documents, such combination being obvious to a person skilled in the art
"L" document which may throw doubts on priority claim(s) or which is cited to establish the publication date of another citation or other special reason (as specified)	"&" document member of the same patent family
"O" document referring to an oral disclosure, use, exhibition or other means	
"P" document published prior to the international filing date but later than the priority date claimed	

Date of the actual completion of the international search 22 SEPTEMBER 1999	Date of mailing of the international search report 27 OCT 1999
--	--

Name and mailing address of the ISA/US Commissioner of Patents and Trademarks Box PCT Washington, D.C. 20231 Facsimile No. (703) 305-3230	Authorized officer TRI M. MAI Telephone No. (703) 308-1038
---	--

Sheila Veney
Sheila Veney
Paralegal Specialist
Technology Center 3700

INTERNATIONAL SEARCH REPORT

International application No.
PCT/US99/16929

C (Continuation). DOCUMENTS CONSIDERED TO BE RELEVANT		
Category*	Citation of document, with indication, where appropriate, of the relevant passages	Relevant to claim No.
A	US 2,672,962 A (KEIRSEY) 23 March 1954, see the entire document	1
A	US 5,894,914 A (JUBIN) 20 April 1999, see the entire document	1