



(51) International Patent Classification:

H04W 74/08 (2009.01) H04W 68/02 (2009.01)
H04W 72/04 (2009.01)

(21) International Application Number:

PCT/SE2020/050116

(22) International Filing Date:

06 February 2020 (06.02.2020)

(25) Filing Language:

English

(26) Publication Language:

English

(30) Priority Data:

62/807,003 18 February 2019 (18.02.2019) US

(71) Applicant: TELEFONAKTIEBOLAGET LM
ERICSSON (PUBL) [SE/SE]; 164 83 Stockholm (SE).

(72) Inventors: LIBERG, Olof; Hornsgatan 45, SE-118 49
STOCKHOLM (SE). HÖGLUND, Andreas; Igelbacken
39, SE-170 62 SOLNA (SE).

(74) Agent: AYOUB, Nabil; Ericsson AB, Patent Unit Kista
RAN 2, 164 80 Stockholm (SE).

(81) Designated States (unless otherwise indicated, for every
kind of national protection available): AE, AG, AL, AM,
AO, AT, AU, AZ, BA, BB, BG, BH, BN, BR, BW, BY, BZ,
CA, CH, CL, CN, CO, CR, CU, CZ, DE, DJ, DK, DM, DO,
DZ, EC, EE, EG, ES, FI, GB, GD, GE, GH, GM, GT, HN,
HR, HU, ID, IL, IN, IR, IS, JO, JP, KE, KG, KH, KN, KP,
KR, KW, KZ, LA, LC, LK, LR, LS, LU, LY, MA, MD, ME,
MG, MK, MN, MW, MX, MY, MZ, NA, NG, NI, NO, NZ,
OM, PA, PE, PG, PH, PL, PT, QA, RO, RS, RU, RW, SA,

SC, SD, SE, SG, SK, SL, ST, SV, SY, TH, TJ, TM, TN, TR,
TT, TZ, UA, UG, US, UZ, VC, VN, WS, ZA, ZM, ZW.

(84) Designated States (unless otherwise indicated, for every
kind of regional protection available): ARIPO (BW, GH,
GM, KE, LR, LS, MW, MZ, NA, RW, SD, SL, ST, SZ, TZ,
UG, ZM, ZW), Eurasian (AM, AZ, BY, KG, KZ, RU, TJ,
TM), European (AL, AT, BE, BG, CH, CY, CZ, DE, DK,
EE, ES, FI, FR, GB, GR, HR, HU, IE, IS, IT, LT, LU, LV,
MC, MK, MT, NL, NO, PL, PT, RO, RS, SE, SI, SK, SM,
TR), OAPI (BF, BJ, CF, CG, CI, CM, GA, GN, GQ, GW,
KM, ML, MR, NE, SN, TD, TG).

Published:

- with international search report (Art. 21(3))
- in black and white; the international application as filed contained color or greyscale and is available for download from PATENTSCOPE

(54) Title: MOBILE TERMINATED ACCESS LOAD CONTROL

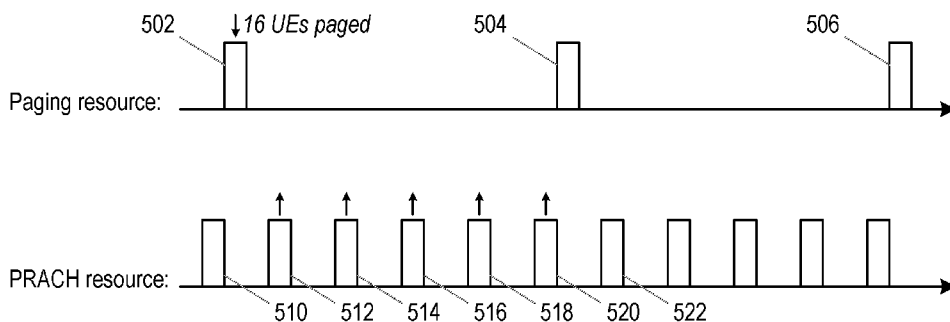

Fig. 5

(57) Abstract: A method is performed by a wireless device for performing a random access. In response to a received paging transmission, and when certain conditions are met, the wireless device randomly selects a random access resource from a plurality of available random access resources. The available random access resources may be spread in time, or in frequency, or in time and frequency. The wireless device then transmits a random access signal on the selected random access resource.



Mobile terminated access load control

Technical Field

- 5 This relates to a method performed by a wireless device, triggered by a network node, for performing a random access.

Background

- 10 In the 3rd Generation Partnership Project (3GPP) Release 8, the Evolved Packet System (EPS) was specified. EPS is based on the Long-Term Evolution (LTE) radio network and the Evolved Packet Core (EPC). It was originally intended to provide voice and mobile broadband (MBB) services but has continuously evolved to broaden its functionality. Since Release 13, Narrowband Internet of Things (NB-IoT) and Long
15 Term Evolution for Machine type communication (LTE-M) are part of the LTE specifications and provide connectivity to massive machine type communications (mMTC) services.

- In 3GPP Release 15, the first release of the 5th Generation network (5G) was
20 developed. This is the next generation radio access technology which is intended to serve use cases such as enhanced mobile broadband (eMBB), ultra-reliable and low latency communication (URLLC) and mMTC. 5G is based on the New Radio (NR) access stratum interface and the 5G Core Network (5GC). The NR physical and higher layers are reusing parts of the LTE specification, and to that add needed components
25 when motivated by the new use cases.

- Both LTE, including LTE-M and NB-IoT, and NR support mobile terminated reachability by means of paging. The LTE and NR paging procedures determine a so-called paging frame (PF) where a UE based on its identity may expect to be paged. The
30 paging frame is determined by a periodicity set by the configured Discontinuous Reception (DRX) or Extended DRX (eDRX) cycle. While a DRX cycle is at most 10 seconds, an eDRX cycle may support a periodicity of up to 1 hour.

- The actual paging transmission is defined by a Physical Downlink Control Channel, a
35 Narrowband Physical Downlink Control Channel or Machine Type Communications (MTC) Physical Downlink Control Channel (N/M)PDCCH, with a Cyclic Redundancy

Code (CRC) scrambled by the Paging Radio Network Temporary Identifier (P-RNTI), transmitted starting in the paging frame. It addresses a (Narrowband) Physical Downlink Shared Channel ((N)PDSCH) which carries a set of UE identities addressing the paged UEs. Each paged UE triggers the random-access procedure for initiating a connection to the network. In LTE, including NB-IoT, up to 16 UEs can be addressed by a single page.

The first step in the random-access procedure is the transmission of a (NB-IoT) Physical Random Access Channel ((N)PRACH) preamble. The (N)PRACH is a collision-based channel, where multiple UEs by accident may use the same preamble when attempting a system access. To keep the likelihood of collision low, a significant part of the available time-frequency resources in an LTE or NR system is reserved for (N)PRACH transmission.

There currently exist certain challenges. In a highly loaded network, up to 16 UEs may be paged together in a single (N)PDSCH, and may trigger the random-access procedure. To cope with 16 simultaneous random access attempts, a large pool of radio resources needs to be reserved for the (N)PRACH. As the number of paged devices will typically be much lower than the maximum supported, it is a waste of resources to provision the (N)PRACH for the worst case. But a lower provision configuration may on the other hand not cope with instantaneous peaks in the paging load.

An Evolved Universal Terrestrial Radio Access Network Node B (eNB) can distribute the paging load in a cell by configuring a high number of paging occasions per DRX cycle. This will reduce the paging load per paging occasion, but instead increase the radio resource consumption for paging, and lead to an inefficient use of the available radio resources.

A potential solution to handle a sudden high load situation is to store the pages in the eNB and spread them in time over consecutive (e)DRX cycles to secure that the maximum instantaneous paging capacity is never utilized. This may however not be an acceptable approach for UEs configured with an eDRX cycle, since this will impose long waiting times for them to connect to the network.

35

Summary

Generally, all terms used herein are to be interpreted according to their ordinary meaning in the relevant technical field, unless a different meaning is clearly given and/or is implied from the context in which it is used. All references to a/an/the
5 element, apparatus, component, means, step, etc. are to be interpreted openly as referring to at least one instance of the element, apparatus, component, means, step, etc., unless explicitly stated otherwise. The steps of any methods disclosed herein do not have to be performed in the exact order disclosed, unless a step is explicitly described as following or preceding another step and/or where it is implicit that a step
10 must follow or precede another step. Any feature of any of the embodiments disclosed herein may be applied to any other embodiment, wherever appropriate. Likewise, any advantage of any of the embodiments may apply to any other embodiments, and vice versa. Other objectives, features and advantages of the enclosed embodiments will be apparent from the following description.

15

Certain aspects of the present disclosure and their embodiments may provide solutions to these or other challenges.

According to a first aspect, there is provided a method performed by a wireless device
20 for performing a random access. The method comprises, in response to a received paging transmission, randomly selecting one random access resource from a plurality of available random access resources spread in time. The method then comprises transmitting a random access signal on the selected random access resource.

25 The random access signal may comprise a random access preamble.

The method may comprise randomly selecting one random access resource from the plurality of available random access resources spread in time in the event that, or when, a predetermined condition is met.

30

Randomly selecting one random access resource from a plurality of available random access resources may comprise:

determining a number of wireless devices that have received the paging transmission; and

35

if it is determined that the number of wireless devices that have received the paging transmission exceeds a threshold number, randomly selecting one random

access resource from the plurality of available random access resources spread in time.

In that case, the method may comprise determining the number of wireless devices
5 that have received the paging transmission from a number of paging records in a Physical Downlink Shared Channel message, and/or determining the number of wireless devices that have received the paging transmission from a length of a paging message on a Physical Downlink Shared Channel.

10 Randomly selecting one random access resource from a plurality of available random access resources spread in time may comprise waiting for a random time before attempting to transmit the random access signal.

The random time may be selected from within a time interval defined by a starting time
15 and by an interval length, and the starting time and the interval length may be determined based on at least one of: the paging configuration, the PRACH configuration, the paging load, the random-access load, the CE level of the device, or the CE level used for the PDCCH scrambled by the P-RNTI transmission.

20 The method may comprise randomly selecting a set of PRACH resources from a plurality of consecutive PRACH resources.

The method may comprise randomly selecting one random access resource from a plurality of available random access resources spread in time in response to receiving
25 a paging transmission in which a Downlink Control Indicator carried by the Physical Downlink Control Channel signals that the wireless device should randomly select one random access resource from the plurality of available random access resources spread in time.

30 Randomly selecting one random access resource from the plurality of available random access resources spread in time may comprise:

when the received paging transmission comprises a control channel message having a Cyclic Redundancy Code scrambled by a first identifier, selecting a predetermined random access resource of the plurality of available random access
35 resources spread in time; and

when the received paging transmission comprises a control channel message having a Cyclic Redundancy Code scrambled by a second identifier, randomly selecting a random access resource from the plurality of available random access resources spread in time.

5

The control channel may comprise a Physical Downlink Control Channel.

The identifier may comprise a Paging Radio Network Temporary Identifier.

10 The method may comprise randomly selecting one random access resource from a plurality of available random access resources spread in time in response to receiving a paging transmission in which a Physical Downlink Shared Channel contains an indication that said wireless device should randomly select one random access resource from the plurality of available random access resources spread in time.

15

According to a second aspect, there is provided a method performed by a base station for configuring a random access by a wireless device. The method comprises causing a paging transmission to be transmitted to the wireless device, wherein the paging transmission causes the wireless device to randomly select one random access resource from a plurality of available random access resources spread in time.

20

The method may further comprise receiving a random access signal from the wireless device on the selected random access resource.

25 The paging transmission may include a Downlink Control Indicator carried by the Physical Downlink Control Channel, indicating that the wireless device should randomly select one random access resource from the plurality of available random access resources spread in time.

30 The method may comprise:

causing a paging transmission to be transmitted to the wireless device, comprising a control channel message having a Cyclic Redundancy Code scrambled by a first identifier, in order to cause the wireless device to select a predetermined random access resource of the plurality of available random access resources spread

35 in time; and

causing a paging transmission to be transmitted to the wireless device, comprising a control channel message having a Cyclic Redundancy Code scrambled by a second identifier, in order to cause the wireless device to randomly select one random access resource from the plurality of available random access resources spread in time.

The control channel may comprise a Physical Downlink Control Channel.

The identifier may comprise a Paging Radio Network Temporary Identifier.

The paging transmission may include a Physical Downlink Shared CHannel containing an indication that said wireless device should select one random access resource from the plurality of available random access resources spread in time.

According to a further aspect, there is provided a wireless device, configured to perform a method according to the first aspect.

According to a further aspect, there is provided a wireless device, the wireless device comprising: processing circuitry configured to perform any of the steps of the method according to the first aspect; and power supply circuitry configured to supply power to the wireless device.

According to a further aspect, there is provided a base station, configured to perform a method according to the second aspect.

According to a further aspect, there is provided a base station, the base station comprising: processing circuitry configured to perform any of the steps of the method according to the second aspect, and power supply circuitry configured to supply power to the base station.

Thus, in some embodiments, there are described mechanisms for spreading a multitude of paging triggered random access attempts in time or frequency.

More specifically, in some embodiments, there is defined a time- and/or frequency-spreading mechanism for distributing the random-access load, that is, the load on the

network arising from paging triggered random access attempts. This averages out the random-access load and allows for a more efficient paging and random access resource configuration.

5 Therefore, certain embodiments may result in a more predictable random-access load, which reduces the need to configure the random-access resources according to the worst possible paging load. The disclosed mechanism to distribute the random-access load therefore avoids having to dimension the (N)PRACH configuration for access load peaks.

10

Brief Description of the Drawings

Reference will now be made, by way of example, to the accompanying drawings, in which:

15

Figure 1 illustrates a part of a cellular communications network, in which the methods disclosed herein may be implemented.

Figure 2 shows a timeline including random access resources.

20

Figure 3 illustrates a method performed by a base station.

Figure 4 is a flow chart, illustrating a method performed by a wireless device.

25 Figure 5 shows a timeline including paging resources

Figure 6 shows a wireless network in accordance with some embodiments.

Figure 7 shows a User Equipment in accordance with some embodiments.

30

Figure 8 shows a virtualization environment in accordance with some embodiments.

Figure 9 shows the connection of a telecommunication network via an intermediate network to a host computer in accordance with some embodiments.

35

Figure 10 shows a host computer communicating via a base station with a user equipment over a partially wireless connection in accordance with some embodiments.

Figure 11 shows methods implemented in a communication system including a host computer, a base station and a user equipment in accordance with some
5 embodiments.

Figure 12 shows methods implemented in a communication system including a host computer, a base station and a user equipment in accordance with some
10 embodiments.

Figure 13 shows methods implemented in a communication system including a host computer, a base station and a user equipment in accordance with some
15 embodiments.

Figure 14 shows methods implemented in a communication system including a host computer, a base station and a user equipment in accordance with some
embodiments.

20 Figure 15 illustrates a virtualization apparatus in accordance with some embodiments.

Figure 16 illustrates a virtualization apparatus in accordance with some embodiments.

25

Detailed Description

Some of the embodiments contemplated herein will now be described more fully with reference to the accompanying drawings. Other embodiments, however, are contained
30 within the scope of the subject matter disclosed herein, the disclosed subject matter should not be construed as limited to only the embodiments set forth herein; rather, these embodiments are provided by way of example to convey the scope of the subject matter to those skilled in the art.

35 Figure 1 illustrates a part of a cellular communications network 100, in which the methods disclosed herein may be implemented.

Specifically, Figure 1 shows a wireless device 102, having a wireless connection to a base station 104 of the radio access network in the cellular communications network 100. The cellular communications network 100 also includes a core network 106.

5

The cellular communications network 100 may for example operate using procedures based on Long Term Evolution, LTE, including LTE-M and NB-IoT, or 5th Generation New Radio, NR, procedures, which support mobile terminated reachability by means of paging. The LTE and NR paging procedures determine a so-called paging frame (PF) where a UE based on its identity may expect to be paged. The paging frame is determined by a periodicity set by the configured Discontinuous Reception (DRX) or Extended DRX (eDRX) cycle.

10

The actual paging transmission is defined by a Physical Downlink Control Channel, Narrowband Physical Downlink Control Channel or MTC Physical Downlink Control Channel (N/M)PDCCH, with a Cyclic Redundancy Code (CRC) scrambled by the Paging Radio Network Temporary Identifier (P-RNTI), transmitted starting in the paging frame. It addresses a (Narrowband) Physical Downlink Shared Channel ((N)PDSCH) which carries a set of UE identities addressing the paged UEs. Each paged UE triggers the random-access procedure for initiating a connection to the network. In LTE, including NB-IoT, up to 16 UEs can be addressed by a single page.

20

The first step in the random-access procedure is the transmission by the UE wireless device of a (NB-IoT) Physical Random Access Channel ((N)PRACH) preamble using a PRACH resource.

25

Figure 2 shows a conventional situation. Figure 2 shows a timeline including paging resources 202, 204, 206, and PRACH resources 210, 212, 214, 216, 218, 220, 222, etc.

30

In the first illustrated paging resource 202, the base station may transmit a paging signal, in which up to 16 UEs may be paged. Any paged UE that wishes to perform a random access will then make a random access attempt in the first PRACH resource 212 following the page. Thus, up to 16 UEs may make a random access attempt in the same PRACH resource 212.

35

In order to reduce the probability of collisions, the base station performs a method 300 as shown in Figure 3.

Specifically, in step 302, the base station causes a paging transmission to be
5 transmitted to the wireless device, wherein the paging transmission causes the wireless device to randomly select one random access resource from a plurality of available random access resources which are spread in time.

Figure 4 is a flow chart, illustrating a method 400 performed by the wireless device.
10

Specifically, in step 402, the wireless device receives the paging transmission from the base station.

In step 404, for example if the paging transmission indicates it, the wireless device
15 randomly selects one random access resource from a plurality of available random access resources spread in time. For example, the wireless device may select a random access resource that occurs after a randomly selected time interval. As another alternative, the wireless device may select a frequency carrier from a plurality of available carriers.

20 Then, in step 406, the wireless device transmits a random access signal to the base station on the selected random access resource.

When the random access procedure is complete, and the wireless device has
25 established a connection with the network, it may provide user data, and forward the user data to a host computer via the transmission to the base station. Similarly, the base station may obtain the user data, and forward the user data to a host computer or a wireless device.

30 Figure 5 shows the effect of the methods described with reference to Figures 3 and 4. Specifically, Figure 5 shows a timeline including paging resources 502, 504, 506, and PRACH resources 510, 512, 514, 516, 518, 520, 522, etc that are defined in frequency and time, such that they are spread in time, that is, they occur over a range of times.

35

In the first illustrated paging resource 502, the base station may transmit a paging signal, in which up to 16 UEs may be paged.

Figure 5 shows the effect of using random access load distribution as described with reference to Figures 3 and 4. In this case, some or all of the paged UEs that wish to perform a random access will wait for a randomly determined time before making a random access attempt. Thus, a UE may not select a preamble from the first available PRACH resource 512, but may wait until N periods later, and perform a random selection of a random access resource from a later PRACH resource.

10

The wait time of N periods should preferably be selected randomly as well. In this illustrative example, the randomly determined wait time is chosen from a range, and the range is determined such that the random access attempt made by a UE that was paged by the paging resource 502 may occur in any one of the five PRACH resources 512, 514, 516, 518, 520 following the page that occur before the next paging opportunity 504. Thus, if random access attempts are made by multiple UEs that were paged by the paging resource 502, it is likely that the random access attempts will be distributed between the multiple PRACH resources 512, 514, 516, 518, 520, and so the maximum load during any one PRACH resource will be reduced.

20

Thus, this mechanism has the effect that the random access attempts, and hence the load of the random access attempts, may be spread in time.

This may be achieved using the Physical Downlink Control Channel, PDCCH.

25

In a first embodiment, the Downlink Control Indicator (DCI) carried by the Narrowband Physical Downlink Control Channel or MTC Physical Downlink Control Channel ((N/M)PDCCH), which is scrambled by the Paging Radio Network Temporary Identifier (P-RNTI), signals to one or more of the UEs addressed by the page that the respective UE or UEs should wait a random time before attempting a (NB-IoT) Physical Random Access Channel ((N)PRACH) preamble transmission.

In another embodiment, the UE also monitors also a second RNTI, P'-RNTI, and, in the case when the paging (N)PDCCH is scrambled with this RNTI, the UE will apply a random wait time for the random access.

35

Alternatively, the spreading may be achieved using the Physical Downlink Shared Channel, PDSCH.

In one embodiment, the (Narrowband) Physical Downlink Shared Channel ((N)PDSCH) that contains the paging records signals to one or more of the UEs addressed by the page that the UE should wait a random time before attempting a (N)PRACH preamble transmission. That is, a flag or indication is added to the paging record per UE.

In one embodiment, a paged UE determines the total number of UEs paged in the same paging occasion. This number can be determined, for example, from the length of the paging message, i.e. the total number of paging records that the paging message contains. If the number of UEs exceeds a threshold number, which may for example be an integer T , it will wait a random time before attempting a (N)PRACH preamble transmission. The threshold number T is signalled to the UE by the network, for example as a parameter in broadcast system information.

In one embodiment, a paged UE estimates the total number of UEs paged in the same paging occasion based on the Transport Block Size (TBS size) configured for the (N)PDSCH transmission. If the TBS size exceeds a threshold value TBS_RAwait , it will wait a random time before attempting a (N)PRACH preamble transmission. The parameter TBS_RAwait may be signalled to the UE by the network, for example in broadcast system information.

In some embodiments, the random time for which the UE waits is distributed within a time interval defined by a starting time and by an interval length defined e.g. in terms of seconds, subframes and/or radio frames.

The starting time and interval length may be determined based on the paging configuration, the PRACH configuration, the paging load, the random-access load, the coverage enhancement (CE) level of the device, or the CE level used for the PDCCH scrambled by the P-RNTI transmission. In one simple example, the starting time is defined from the end of the paging transmission, and the interval length is defined to be smaller than time until the next paging resource.

As an alternative to a wait time, the UEs being paged may be randomly distributed over a number of time consecutive PRACH resources. This number, M , can be determined

by the paging configuration, the PRACH configuration, the paging load, the random access load, etc.

The distributions can be uniform or of any other form.

5

In one embodiment, it is indicated to UEs in system information if a random wait time before attempting a (N)PRACH preamble transmission should be applied in the cell. Also the wait time value, or the value of the number M, that is, the number of PRACH resources over which the UEs may be randomly distributed, can be signalled to UEs in broadcast system information.

10

As an alternative to spreading the access load in time, the devices may be required to spread the access load in the frequency domain. In the specific case of Long Term Evolution for Machines (LTE M), PRACH resources may be configured on multiple narrowbands. In NB IoT, NPRACH resources may be configured on multiple carriers, or Physical Resource Blocks (PRBs). The (N/M)PDCCH and/or (N)PDSCH signalling outlined above for spreading the random-access load in time may therefore as an alternative indicate a spreading over (N)PRACH resources on additional LTE M narrowbands or NB IoT PRBs. More specifically, the signalling may cause the UE to randomly select one of the available (and by Radio Resource Control (RRC) configured) carriers for performing its random access.

15

20

In a further embodiment, the methods for spreading the random access attempts, and hence the associated load, in time and for spreading in frequency may both be applied, so that the random access attempts from paged devices, and hence the load on the network, are spread both in time and in frequency.

25

According to one aspect, there is provided a method performed by a wireless device for performing a random access, the method comprising:
in response to a received paging transmission, selecting one random access resource from a plurality of available random access resources; and
transmitting a random access signal on the selected random access resource.

30

The method may comprise randomly selecting one random access resource from a plurality of available random access resources.

35

The random access signal may comprise a random access preamble.

The method may comprise selecting one random access resource from the plurality of
5 available random access resources in the event that a predetermined condition is met.

The step of selecting one random access resource from a plurality of available random
access resources may comprise:

determining a number of wireless devices that have received the paging transmission;
10 and

if it is determined that the number of wireless devices that have received the paging
transmission exceeds a threshold number, selecting one random access resource from
the plurality of available random access resources.

15 The method may comprise determining the threshold number from signalling received
by the wireless device.

The method may comprise determining the threshold number from system information
broadcast by a network node.

20 The method may comprise determining the number of wireless devices that have
received the paging transmission from a number of paging records in a Physical
Downlink Shared Channel message.

25 The step of selecting one random access resource from a plurality of available random
access resources may comprise waiting for a random time before attempting to
transmit the random access signal.

The random time may be selected from within a time interval defined by a starting time
30 and by an interval length.

The starting time and the interval length may be determined based on at least one of:
the paging configuration, the PRACH configuration, the paging load, the random-
access load, the CE level of the device, or the CE level used for the PDCCH scrambled
35 by the P-RNTI transmission.

The method may comprise randomly selecting a set of PRACH resources from a plurality of consecutive PRACH resources.

5 The step of selecting one random access resource from a plurality of available random access resources may comprise selecting one random access frequency resource from a plurality of available random access frequency resources.

10 The method may comprise randomly selecting one available carrier frequency from a plurality of available carrier frequencies.

The method may comprise selecting one random access resource from a plurality of available random access resources in response to receiving a paging transmission in which a Downlink Control Indicator carried by the Physical Downlink Control Channel signals that the wireless device should select one random access resource from the plurality of available random access resources.

15 The step of selecting one random access resource from the plurality of available random access resources may comprise:
when the received paging transmission comprises a control channel scrambled by a first identifier, selecting a predetermined random access resource of the plurality of available random access resources; and
when the received paging transmission comprises a control channel scrambled by a second identifier, randomly selecting a random access resource from the plurality of available random access resources.

20 The control channel may comprise a Physical Downlink Control Channel.

The identifier may comprise a Paging Radio Network Temporary Identifier.

30 The method may comprise selecting one random access resource from a plurality of available random access resources in response to receiving a paging transmission in which a Physical Downlink Shared Channel contains an indication that said wireless device should select one random access resource from the plurality of available random access resources.

35 The method may further comprise:

- providing user data; and
- forwarding the user data to a host computer via the transmission to the base station.

5 According to one aspect, there is provided a method performed by a base station for configuring a random access by a wireless device, the method comprising:
causing a paging transmission to be transmitted to the wireless device,
wherein the paging transmission causes the wireless device to select one random
access resource from a plurality of available random access resources.

10

The method may further comprise receiving a random access signal from the wireless device on the selected random access resource.

The paging transmission may cause the wireless device to randomly select one
15 random access resource from a plurality of available random access resources.

The method may comprise signaling to the wireless device a threshold number of wireless devices, such that the wireless device selects one random access resource from the plurality of available random access resources if it determines that the number
20 of wireless devices that have received the paging transmission exceeds a threshold number.

The paging transmission may include a Downlink Control Indicator carried by the Physical Downlink Control Channel, indicating that the wireless device should select
25 one random access resource from the plurality of available random access resources.

The method may comprise:
causing a paging transmission to be transmitted to the wireless device, comprising a control channel scrambled by a first identifier, in order to cause the wireless device to
30 select a predetermined random access resource of the plurality of available random access resources; and
causing a paging transmission to be transmitted to the wireless device, comprising a control channel scrambled by a second identifier, in order to cause the wireless device to randomly select.

35

The control channel may comprise a Physical Downlink Control Channel.

The identifier may comprise a Paging Radio Network Temporary Identifier.

The paging transmission may include a Physical Downlink Shared CHannel containing
5 an indication that said wireless device should select one random access resource from
the plurality of available random access resources.

The method may further comprise:

- obtaining user data; and
- 10 - forwarding the user data to a host computer or a wireless device.

According to another aspect, there is provided a wireless device, the wireless device comprising:

- processing circuitry configured to perform any of the steps of any of the methods
15 performed by the wireless device; and
- power supply circuitry configured to supply power to the wireless device.

According to another aspect, there is provided a base station, the base station comprising:

- 20 - processing circuitry configured to perform any of the steps of any of the methods
performed by the base station;
- power supply circuitry configured to supply power to the base station.

According to another aspect, there is provided a user equipment (UE), the UE
25 comprising:

- an antenna configured to send and receive wireless signals;
- radio front-end circuitry connected to the antenna and to processing circuitry, and
configured to condition signals communicated between the antenna and the processing
circuitry;
- 30 - the processing circuitry being configured to perform any of the steps of any of the
methods performed by the wireless device;
- an input interface connected to the processing circuitry and configured to allow
input of information into the UE to be processed by the processing circuitry;
- an output interface connected to the processing circuitry and configured to output
35 information from the UE that has been processed by the processing circuitry; and

- a battery connected to the processing circuitry and configured to supply power to the UE.

According to another aspect, there is provided a communication system including a
5 host computer comprising:

- processing circuitry configured to provide user data; and
- a communication interface configured to forward the user data to a cellular network for transmission to a user equipment (UE),
- wherein the cellular network comprises a base station having a radio interface
10 and processing circuitry, the base station's processing circuitry configured to perform any of the steps of any of the methods performed by the base station.

According to another aspect, there is provided a communication system according to the previous aspect further including the base station.

15

According to another aspect, there is provided a communication system according to the previous 2 aspects, further including the UE, wherein the UE is configured to communicate with the base station.

20 According to another aspect, there is provided a communication system according to the previous 3 embodiments, wherein:

- the processing circuitry of the host computer is configured to execute a host application, thereby providing the user data; and
- the UE comprises processing circuitry configured to execute a client application
25 associated with the host application.

According to another aspect, there is provided a method implemented in a communication system including a host computer, a base station and a user equipment (UE), the method comprising:

- 30 - at the host computer, providing user data; and
- at the host computer, initiating a transmission carrying the user data to the UE via a cellular network comprising the base station, wherein the base station performs any of the steps of any of the method performed by the base station.

35 According to another aspect, there is provided a method according to the previous aspect, further comprising, at the base station, transmitting the user data.

According to another aspect, there is provided a method according to the previous 2 aspects, wherein the user data is provided at the host computer by executing a host application, the method further comprising, at the UE, executing a client application
5 associated with the host application.

According to another aspect, there is provided a user equipment (UE) configured to communicate with a base station, the UE comprising a radio interface and processing circuitry configured to perform the method of the previous 3 aspects.
10

According to another aspect, there is provided a communication system including a host computer comprising:

- processing circuitry configured to provide user data; and
- a communication interface configured to forward user data to a cellular network
15 for transmission to a user equipment (UE),
- wherein the UE comprises a radio interface and processing circuitry, the UE's components configured to perform any of the steps of any of the methods performed by the wireless device.

20 According to another aspect, the communication system of the previous aspect may further include a base station configured to communicate with the UE.

According to another aspect, there is provided a communication system according to the previous 2 aspects, wherein:

- 25 - the processing circuitry of the host computer is configured to execute a host application, thereby providing the user data; and
- the UE's processing circuitry is configured to execute a client application associated with the host application.

30 According to another aspect, there is provided a method implemented in a communication system including a host computer, a base station and a user equipment (UE), the method comprising:

- at the host computer, providing user data; and
- at the host computer, initiating a transmission carrying the user data to the UE via
35 a cellular network comprising the base station, wherein the UE performs any of the steps of any of the methods performed by the wireless device.

According to another aspect, the method of the previous embodiment may further comprise at the UE, receiving the user data from the base station.

- 5 According to another aspect, there is provided a communication system including a host computer comprising:
- communication interface configured to receive user data originating from a transmission from a user equipment (UE) to a base station,
 - wherein the UE comprises a radio interface and processing circuitry, the UE's
- 10 processing circuitry configured to perform any of the steps of any of the methods performed by the wireless device.

According to another aspect, the communication system of the previous embodiment may further include the UE.

15

- According to another aspect, the communication system of the previous 2 embodiments may further include the base station, wherein the base station comprises a radio interface configured to communicate with the UE and a communication interface configured to forward to the host computer the user data carried by a
- 20 transmission from the UE to the base station.

According to another aspect, there is provided a communication system according to the previous 3 embodiments, wherein:

- the processing circuitry of the host computer is configured to execute a host
- 25 application; and
- the UE's processing circuitry is configured to execute a client application associated with the host application, thereby providing the user data.

According to another aspect, there is provided a communication system of the previous

30 4 embodiments, wherein:

- the processing circuitry of the host computer is configured to execute a host application, thereby providing request data; and
 - the UE's processing circuitry is configured to execute a client application associated with the host application, thereby providing the user data in response to the
- 35 request data.

According to another aspect, there is provided a method implemented in a communication system including a host computer, a base station and a user equipment (UE), the method comprising:

- at the host computer, receiving user data transmitted to the base station from the UE, wherein the UE performs any of the steps of any of the methods performed by the wireless device.

According to another aspect, the method of the previous embodiment may further comprise, at the UE, providing the user data to the base station.

10

According to another aspect, the method of the previous 2 embodiments may further comprise:

- at the UE, executing a client application, thereby providing the user data to be transmitted; and
- at the host computer, executing a host application associated with the client application.

15

According to another aspect, the method of the previous 3 embodiments may further comprise:

- at the UE, executing a client application; and
- at the UE, receiving input data to the client application, the input data being provided at the host computer by executing a host application associated with the client application,
- wherein the user data to be transmitted is provided by the client application in response to the input data.

20

25

According to another aspect, there is provided a communication system including a host computer comprising a communication interface configured to receive user data originating from a transmission from a user equipment (UE) to a base station, wherein the base station comprises a radio interface and processing circuitry, the base station's processing circuitry configured to perform any of the steps of any of the methods performed by the base station.

30

According to another aspect, the communication system of the previous aspect further includes the base station.

35

According to another aspect, the communication system of the previous 2 embodiments further includes the UE, wherein the UE is configured to communicate with the base station.

- 5 According to another aspect, there is provided a communication system according to the previous 3 embodiments, wherein:
- the processing circuitry of the host computer is configured to execute a host application;
 - the UE is configured to execute a client application associated with the host
- 10 application, thereby providing the user data to be received by the host computer.

According to another aspect, there is provided a method implemented in a communication system including a host computer, a base station and a user equipment (UE), the method comprising:

- 15 - at the host computer, receiving, from the base station, user data originating from a transmission which the base station has received from the UE, wherein the UE performs any of the steps of any of the methods performed by the wireless device.

According to another aspect, the method of the previous aspect further comprises, at 20 the base station, receiving the user data from the UE.

According to another aspect, the method of the previous 2 aspects further comprises at the base station, initiating a transmission of the received user data to the host

25

Figure 6 illustrates a wireless network in accordance with some embodiments.

Although the subject matter described herein may be implemented in any appropriate 30 type of system using any suitable components, the embodiments disclosed herein are described in relation to a wireless network, such as the example wireless network illustrated in Figure 6. For simplicity, the wireless network of Figure 6 only depicts network 606, network nodes 660 and 660b, and WDs 610, 610b, and 610c. In practice, a wireless network may further include any additional elements suitable to 35 support communication between wireless devices or between a wireless device and another communication device, such as a landline telephone, a service provider, or any

other network node or end device. Of the illustrated components, network node 660 and wireless device (WD) 610 are depicted with additional detail. The wireless network may provide communication and other types of services to one or more wireless devices to facilitate the wireless devices' access to and/or use of the services provided by, or via, the wireless network.

The wireless network may comprise and/or interface with any type of communication, telecommunication, data, cellular, and/or radio network or other similar type of system. In some embodiments, the wireless network may be configured to operate according to specific standards or other types of predefined rules or procedures. Thus, particular embodiments of the wireless network may implement communication standards, such as Global System for Mobile Communications (GSM), Universal Mobile Telecommunications System (UMTS), Long Term Evolution (LTE), and/or other suitable 2G, 3G, 4G, or 5G standards; wireless local area network (WLAN) standards, such as the IEEE 802.11 standards; and/or any other appropriate wireless communication standard, such as the Worldwide Interoperability for Microwave Access (WiMax), Bluetooth, Z-Wave and/or ZigBee standards.

Network 606 may comprise one or more backhaul networks, core networks, IP networks, public switched telephone networks (PSTNs), packet data networks, optical networks, wide-area networks (WANs), local area networks (LANs), wireless local area networks (WLANs), wired networks, wireless networks, metropolitan area networks, and other networks to enable communication between devices.

Network node 660 and WD 610 comprise various components described in more detail below. These components work together in order to provide network node and/or wireless device functionality, such as providing wireless connections in a wireless network. In different embodiments, the wireless network may comprise any number of wired or wireless networks, network nodes, base stations, controllers, wireless devices, relay stations, and/or any other components or systems that may facilitate or participate in the communication of data and/or signals whether via wired or wireless connections.

As used herein, network node refers to equipment capable, configured, arranged and/or operable to communicate directly or indirectly with a wireless device and/or with other network nodes or equipment in the wireless network to enable and/or provide

wireless access to the wireless device and/or to perform other functions (e.g., administration) in the wireless network. Examples of network nodes include, but are not limited to, access points (APs) (e.g., radio access points), base stations (BSs) (e.g., radio base stations, Node Bs, evolved Node Bs (eNBs) and NR NodeBs (gNBs)). Base stations may be categorized based on the amount of coverage they provide (or, stated differently, their transmit power level) and may then also be referred to as femto base stations, pico base stations, micro base stations, or macro base stations. A base station may be a relay node or a relay donor node controlling a relay. A network node may also include one or more (or all) parts of a distributed radio base station such as centralized digital units and/or remote radio units (RRUs), sometimes referred to as Remote Radio Heads (RRHs). Such remote radio units may or may not be integrated with an antenna as an antenna integrated radio. Parts of a distributed radio base station may also be referred to as nodes in a distributed antenna system (DAS). Yet further examples of network nodes include multi-standard radio (MSR) equipment such as MSR BSs, network controllers such as radio network controllers (RNCs) or base station controllers (BSCs), base transceiver stations (BTSs), transmission points, transmission nodes, multi-cell/multicast coordination entities (MCEs), core network nodes (e.g., Mobile Switching Centers (MSCs), Mobility Management Entities (MMEs), Operations and Maintenance (O&M) nodes, Operations and Support System (OSS) nodes, Self-Organizing Networks (SON) nodes, positioning nodes (e.g., Evolved-Serving Mobile Location Centres (E-SMLCs)), and/or Minimization of Drive Test nodes (MDTs). As another example, a network node may be a virtual network node as described in more detail below. More generally, however, network nodes may represent any suitable device (or group of devices) capable, configured, arranged, and/or operable to enable and/or provide a wireless device with access to the wireless network or to provide some service to a wireless device that has accessed the wireless network.

In Figure 6, network node 660 includes processing circuitry 670, device readable medium 680, interface 690, auxiliary equipment 684, power source 686, power circuitry 687, and antenna 662. Although network node 660 illustrated in the example wireless network of Figure 6 may represent a device that includes the illustrated combination of hardware components, other embodiments may comprise network nodes with different combinations of components. It is to be understood that a network node comprises any suitable combination of hardware and/or software needed to perform the tasks, features, functions and methods disclosed herein. Moreover, while the components of

network node 660 are depicted as single boxes located within a larger box, or nested within multiple boxes, in practice, a network node may comprise multiple different physical components that make up a single illustrated component (e.g., device readable medium 680 may comprise multiple separate hard drives as well as multiple
5 RAM modules).

Similarly, network node 660 may be composed of multiple physically separate components (e.g., a NodeB component and a RNC component, or a BTS component and a BSC component, etc.), which may each have their own respective components.
10 In certain scenarios in which network node 660 comprises multiple separate components (e.g., BTS and BSC components), one or more of the separate components may be shared among several network nodes. For example, a single RNC may control multiple NodeB's. In such a scenario, each unique NodeB and RNC pair, may in some instances be considered a single separate network node. In some
15 embodiments, network node 660 may be configured to support multiple radio access technologies (RATs). In such embodiments, some components may be duplicated (e.g., separate device readable medium 680 for the different RATs) and some components may be reused (e.g., the same antenna 662 may be shared by the RATs). Network node 660 may also include multiple sets of the various illustrated components
20 for different wireless technologies integrated into network node 660, such as, for example, GSM, Wideband Code Division Multiplexing Access (WCDMA), LTE, NR, WiFi, or Bluetooth wireless technologies. These wireless technologies may be integrated into the same or different chip or set of chips and other components within network node 660.

25 Processing circuitry 670 is configured to perform any determining, calculating, or similar operations (e.g., certain obtaining operations) described herein as being provided by a network node. These operations performed by processing circuitry 670 may include processing information obtained by processing circuitry 670 by, for
30 example, converting the obtained information into other information, comparing the obtained information or converted information to information stored in the network node, and/or performing one or more operations based on the obtained information or converted information, and as a result of said processing making a determination. Processing circuitry 670 may comprise a combination of one or more of a
35 microprocessor, controller, microcontroller, central processing unit, digital signal processor, application-specific integrated circuit, field programmable gate array, or any

other suitable computing device, resource, or combination of hardware, software and/or encoded logic operable to provide, either alone or in conjunction with other network node 660 components, such as device readable medium 680, network node 660 functionality. For example, processing circuitry 670 may execute instructions stored in
5 device readable medium 680 or in memory within processing circuitry 670. Such functionality may include providing any of the various wireless features, functions, or benefits discussed herein. In some embodiments, processing circuitry 670 may include a system on a chip (SOC).

10 In some embodiments, processing circuitry 670 may include one or more of radio frequency (RF) transceiver circuitry 672 and baseband processing circuitry 674. In some embodiments, radio frequency (RF) transceiver circuitry 672 and baseband processing circuitry 674 may be on separate chips (or sets of chips), boards, or units, such as radio units and digital units. In alternative embodiments, part or all of RF
15 transceiver circuitry 672 and baseband processing circuitry 674 may be on the same chip or set of chips, boards, or units

In certain embodiments, some or all of the functionality described herein as being provided by a network node, base station, eNB or other such network device may be
20 performed by processing circuitry 670 executing instructions stored on device readable medium 680 or memory within processing circuitry 670. In alternative embodiments, some or all of the functionality may be provided by processing circuitry 670 without executing instructions stored on a separate or discrete device readable medium, such as in a hard-wired manner. In any of those embodiments, whether executing
25 instructions stored on a device readable storage medium or not, processing circuitry 670 can be configured to perform the described functionality. The benefits provided by such functionality are not limited to processing circuitry 670 alone or to other components of network node 660, but are enjoyed by network node 660 as a whole, and/or by end users and the wireless network generally.

30 Device readable medium 680 may comprise any form of volatile or non-volatile computer readable memory including, without limitation, persistent storage, solid-state memory, remotely mounted memory, magnetic media, optical media, random access memory (RAM), read-only memory (ROM), mass storage media (for example, a hard
35 disk), removable storage media (for example, a flash drive, a Compact Disk (CD) or a Digital Video Disk (DVD)), and/or any other volatile or non-volatile, non-transitory

device readable and/or computer-executable memory devices that store information, data, and/or instructions that may be used by processing circuitry 670. Device readable medium 680 may store any suitable instructions, data or information, including a computer program, software, an application including one or more of logic, rules, code, tables, etc. and/or other instructions capable of being executed by processing circuitry 670 and, utilized by network node 660. Device readable medium 680 may be used to store any calculations made by processing circuitry 670 and/or any data received via interface 690. In some embodiments, processing circuitry 670 and device readable medium 680 may be considered to be integrated.

10

Interface 690 is used in the wired or wireless communication of signalling and/or data between network node 660, network 606, and/or WDs 610. As illustrated, interface 690 comprises port(s)/terminal(s) 694 to send and receive data, for example to and from network 606 over a wired connection. Interface 690 also includes radio front end circuitry 692 that may be coupled to, or in certain embodiments a part of, antenna 662. Radio front end circuitry 692 comprises filters 698 and amplifiers 696. Radio front end circuitry 692 may be connected to antenna 662 and processing circuitry 670. Radio front end circuitry may be configured to condition signals communicated between antenna 662 and processing circuitry 670. Radio front end circuitry 692 may receive digital data that is to be sent out to other network nodes or WDs via a wireless connection. Radio front end circuitry 692 may convert the digital data into a radio signal having the appropriate channel and bandwidth parameters using a combination of filters 698 and/or amplifiers 696. The radio signal may then be transmitted via antenna 662. Similarly, when receiving data, antenna 662 may collect radio signals which are then converted into digital data by radio front end circuitry 692. The digital data may be passed to processing circuitry 670. In other embodiments, the interface may comprise different components and/or different combinations of components.

15

20

25

30

35

In certain alternative embodiments, network node 660 may not include separate radio front end circuitry 692, instead, processing circuitry 670 may comprise radio front end circuitry and may be connected to antenna 662 without separate radio front end circuitry 692. Similarly, in some embodiments, all or some of RF transceiver circuitry 672 may be considered a part of interface 690. In still other embodiments, interface 690 may include one or more ports or terminals 694, radio front end circuitry 692, and RF transceiver circuitry 672, as part of a radio unit (not shown), and interface 690 may communicate with baseband processing circuitry 674, which is part of a digital unit (not shown).

Antenna 662 may include one or more antennas, or antenna arrays, configured to send and/or receive wireless signals. Antenna 662 may be coupled to radio front end circuitry 690 and may be any type of antenna capable of transmitting and receiving data and/or signals wirelessly. In some embodiments, antenna 662 may comprise one or more omni-directional, sector or panel antennas operable to transmit/receive radio signals between, for example, 2 GHz and 66 GHz. An omni-directional antenna may be used to transmit/receive radio signals in any direction, a sector antenna may be used to transmit/receive radio signals from devices within a particular area, and a panel antenna may be a line of sight antenna used to transmit/receive radio signals in a relatively straight line. In some instances, the use of more than one antenna may be referred to as MIMO. In certain embodiments, antenna 662 may be separate from network node 660 and may be connectable to network node 660 through an interface or port.

15

Antenna 662, interface 690, and/or processing circuitry 670 may be configured to perform any receiving operations and/or certain obtaining operations described herein as being performed by a network node. Any information, data and/or signals may be received from a wireless device, another network node and/or any other network equipment. Similarly, antenna 662, interface 690, and/or processing circuitry 670 may be configured to perform any transmitting operations described herein as being performed by a network node. Any information, data and/or signals may be transmitted to a wireless device, another network node and/or any other network equipment. Power circuitry 687 may comprise, or be coupled to, power management circuitry and is configured to supply the components of network node 660 with power for performing the functionality described herein. Power circuitry 687 may receive power from power source 686. Power source 686 and/or power circuitry 687 may be configured to provide power to the various components of network node 660 in a form suitable for the respective components (e.g., at a voltage and current level needed for each respective component). Power source 686 may either be included in, or external to, power circuitry 687 and/or network node 660. For example, network node 660 may be connectable to an external power source (e.g., an electricity outlet) via an input circuitry or interface such as an electrical cable, whereby the external power source supplies power to power circuitry 687. As a further example, power source 686 may comprise a source of power in the form of a battery or battery pack which is connected to, or integrated in, power circuitry 687. The battery may provide backup power should the

30
35

external power source fail. Other types of power sources, such as photovoltaic devices, may also be used.

Alternative embodiments of network node 660 may include additional components
5 beyond those shown in Figure 6 that may be responsible for providing certain aspects of the network node's functionality, including any of the functionality described herein and/or any functionality necessary to support the subject matter described herein. For example, network node 660 may include user interface equipment to allow input of information into network node 660 and to allow output of information from network node
10 660. This may allow a user to perform diagnostic, maintenance, repair, and other administrative functions for network node 660.

As used herein, wireless device (WD) refers to a device capable, configured, arranged and/or operable to communicate wirelessly with network nodes and/or other wireless
15 devices. Unless otherwise noted, the term WD may be used interchangeably herein with user equipment (UE). Communicating wirelessly may involve transmitting and/or receiving wireless signals using electromagnetic waves, radio waves, infrared waves, and/or other types of signals suitable for conveying information through air. In some embodiments, a WD may be configured to transmit and/or receive information without
20 direct human interaction. For instance, a WD may be designed to transmit information to a network on a predetermined schedule, when triggered by an internal or external event, or in response to requests from the network. Examples of a WD include, but are not limited to, a smart phone, a mobile phone, a cell phone, a voice over IP (VoIP) phone, a wireless local loop phone, a desktop computer, a personal digital assistant
25 (PDA), a wireless cameras, a gaming console or device, a music storage device, a playback appliance, a wearable terminal device, a wireless endpoint, a mobile station, a tablet, a laptop, a laptop-embedded equipment (LEE), a laptop-mounted equipment (LME), a smart device, a wireless customer-premise equipment (CPE), a vehicle-mounted wireless terminal device, etc.. A WD may support device-to-device (D2D)
30 communication, for example by implementing a 3GPP standard for sidelink communication, vehicle-to-vehicle (V2V), vehicle-to-infrastructure (V2I), vehicle-to-everything (V2X) and may in this case be referred to as a D2D communication device. As yet another specific example, in an Internet of Things (IoT) scenario, a WD may represent a machine or other device that performs monitoring and/or measurements,
35 and transmits the results of such monitoring and/or measurements to another WD and/or a network node. The WD may in this case be a machine-to-machine (M2M)

device, which may in a 3GPP context be referred to as an MTC device. As one particular example, the WD may be a UE implementing the 3GPP narrow band internet of things (NB-IoT) standard. Particular examples of such machines or devices are sensors, metering devices such as power meters, industrial machinery, or home or personal appliances (e.g. refrigerators, televisions, etc.) personal wearables (e.g., watches, fitness trackers, etc.). In other scenarios, a WD may represent a vehicle or other equipment that is capable of monitoring and/or reporting on its operational status or other functions associated with its operation. A WD as described above may represent the endpoint of a wireless connection, in which case the device may be referred to as a wireless terminal. Furthermore, a WD as described above may be mobile, in which case it may also be referred to as a mobile device or a mobile terminal.

As illustrated, wireless device 610 includes antenna 611, interface 614, processing circuitry 620, device readable medium 630, user interface equipment 632, auxiliary equipment 634, power source 636 and power circuitry 637. WD 610 may include multiple sets of one or more of the illustrated components for different wireless technologies supported by WD 610, such as, for example, GSM, WCDMA, LTE, NR, WiFi, WiMAX, or Bluetooth wireless technologies, just to mention a few. These wireless technologies may be integrated into the same or different chips or set of chips as other components within WD 610.

Antenna 611 may include one or more antennas or antenna arrays, configured to send and/or receive wireless signals, and is connected to interface 614. In certain alternative embodiments, antenna 611 may be separate from WD 610 and be connectable to WD 610 through an interface or port. Antenna 611, interface 614, and/or processing circuitry 620 may be configured to perform any receiving or transmitting operations described herein as being performed by a WD. Any information, data and/or signals may be received from a network node and/or another WD. In some embodiments, radio front end circuitry and/or antenna 611 may be considered an interface.

As illustrated, interface 614 comprises radio front end circuitry 612 and antenna 611. Radio front end circuitry 612 comprise one or more filters 618 and amplifiers 616. Radio front end circuitry 614 is connected to antenna 611 and processing circuitry 620, and is configured to condition signals communicated between antenna 611 and

processing circuitry 620. Radio front end circuitry 612 may be coupled to or a part of antenna 611. In some embodiments, WD 610 may not include separate radio front end circuitry 612; rather, processing circuitry 620 may comprise radio front end circuitry and may be connected to antenna 611. Similarly, in some embodiments, some or all of RF transceiver circuitry 622 may be considered a part of interface 614. Radio front end circuitry 612 may receive digital data that is to be sent out to other network nodes or WDs via a wireless connection. Radio front end circuitry 612 may convert the digital data into a radio signal having the appropriate channel and bandwidth parameters using a combination of filters 618 and/or amplifiers 616. The radio signal may then be transmitted via antenna 611. Similarly, when receiving data, antenna 611 may collect radio signals which are then converted into digital data by radio front end circuitry 612. The digital data may be passed to processing circuitry 620. In other embodiments, the interface may comprise different components and/or different combinations of components.

Processing circuitry 620 may comprise a combination of one or more of a microprocessor, controller, microcontroller, central processing unit, digital signal processor, application-specific integrated circuit, field programmable gate array, or any other suitable computing device, resource, or combination of hardware, software, and/or encoded logic operable to provide, either alone or in conjunction with other WD 610 components, such as device readable medium 630, WD 610 functionality. Such functionality may include providing any of the various wireless features or benefits discussed herein. For example, processing circuitry 620 may execute instructions stored in device readable medium 630 or in memory within processing circuitry 620 to provide the functionality disclosed herein.

As illustrated, processing circuitry 620 includes one or more of RF transceiver circuitry 622, baseband processing circuitry 624, and application processing circuitry 626. In other embodiments, the processing circuitry may comprise different components and/or different combinations of components. In certain embodiments processing circuitry 620 of WD 610 may comprise a SOC. In some embodiments, RF transceiver circuitry 622, baseband processing circuitry 624, and application processing circuitry 626 may be on separate chips or sets of chips. In alternative embodiments, part or all of baseband processing circuitry 624 and application processing circuitry 626 may be combined into one chip or set of chips, and RF transceiver circuitry 622 may be on a separate chip or set of chips. In still alternative embodiments, part or all of RF transceiver circuitry 622

and baseband processing circuitry 624 may be on the same chip or set of chips, and application processing circuitry 626 may be on a separate chip or set of chips. In yet other alternative embodiments, part or all of RF transceiver circuitry 622, baseband processing circuitry 624, and application processing circuitry 626 may be combined in the same chip or set of chips. In some embodiments, RF transceiver circuitry 622 may be a part of interface 614. RF transceiver circuitry 622 may condition RF signals for processing circuitry 620.

In certain embodiments, some or all of the functionality described herein as being performed by a WD may be provided by processing circuitry 620 executing instructions stored on device readable medium 630, which in certain embodiments may be a computer-readable storage medium. In alternative embodiments, some or all of the functionality may be provided by processing circuitry 620 without executing instructions stored on a separate or discrete device readable storage medium, such as in a hard-wired manner. In any of those particular embodiments, whether executing instructions stored on a device readable storage medium or not, processing circuitry 620 can be configured to perform the described functionality. The benefits provided by such functionality are not limited to processing circuitry 620 alone or to other components of WD 610, but are enjoyed by WD 610 as a whole, and/or by end users and the wireless network generally.

Processing circuitry 620 may be configured to perform any determining, calculating, or similar operations (e.g., certain obtaining operations) described herein as being performed by a WD. These operations, as performed by processing circuitry 620, may include processing information obtained by processing circuitry 620 by, for example, converting the obtained information into other information, comparing the obtained information or converted information to information stored by WD 610, and/or performing one or more operations based on the obtained information or converted information, and as a result of said processing making a determination.

Device readable medium 630 may be operable to store a computer program, software, an application including one or more of logic, rules, code, tables, etc. and/or other instructions capable of being executed by processing circuitry 620. Device readable medium 630 may include computer memory (e.g., Random Access Memory (RAM) or Read Only Memory (ROM)), mass storage media (e.g., a hard disk), removable storage media (e.g., a Compact Disk (CD) or a Digital Video Disk (DVD)), and/or any

other volatile or non-volatile, non-transitory device readable and/or computer executable memory devices that store information, data, and/or instructions that may be used by processing circuitry 620. In some embodiments, processing circuitry 620 and device readable medium 630 may be considered to be integrated.

5

User interface equipment 632 may provide components that allow for a human user to interact with WD 610. Such interaction may be of many forms, such as visual, audial, tactile, etc. User interface equipment 632 may be operable to produce output to the user and to allow the user to provide input to WD 610. The type of interaction may vary
10 depending on the type of user interface equipment 632 installed in WD 610. For example, if WD 610 is a smart phone, the interaction may be via a touch screen; if WD 610 is a smart meter, the interaction may be through a screen that provides usage (e.g., the number of gallons used) or a speaker that provides an audible alert (e.g., if smoke is detected). User interface equipment 632 may include input interfaces,
15 devices and circuits, and output interfaces, devices and circuits. User interface equipment 632 is configured to allow input of information into WD 610, and is connected to processing circuitry 620 to allow processing circuitry 620 to process the input information. User interface equipment 632 may include, for example, a
20 microphone, a proximity or other sensor, keys/buttons, a touch display, one or more cameras, a USB port, or other input circuitry. User interface equipment 632 is also configured to allow output of information from WD 610, and to allow processing circuitry 620 to output information from WD 610. User interface equipment 632 may include, for example, a speaker, a display, vibrating circuitry, a USB port, a headphone interface, or other output circuitry. Using one or more input and output interfaces, devices, and
25 circuits, of user interface equipment 632, WD 610 may communicate with end users and/or the wireless network, and allow them to benefit from the functionality described herein.

Auxiliary equipment 634 is operable to provide more specific functionality which may
30 not be generally performed by WDs. This may comprise specialized sensors for doing measurements for various purposes, interfaces for additional types of communication such as wired communications etc. The inclusion and type of components of auxiliary equipment 634 may vary depending on the embodiment and/or scenario.

35 Power source 636 may, in some embodiments, be in the form of a battery or battery pack. Other types of power sources, such as an external power source (e.g., an

electricity outlet), photovoltaic devices or power cells, may also be used. WD 610 may further comprise power circuitry 637 for delivering power from power source 636 to the various parts of WD 610 which need power from power source 636 to carry out any functionality described or indicated herein. Power circuitry 637 may in certain
5 embodiments comprise power management circuitry. Power circuitry 637 may additionally or alternatively be operable to receive power from an external power source; in which case WD 610 may be connectable to the external power source (such as an electricity outlet) via input circuitry or an interface such as an electrical power cable. Power circuitry 637 may also in certain embodiments be operable to deliver
10 power from an external power source to power source 636. This may be, for example, for the charging of power source 636. Power circuitry 637 may perform any formatting, converting, or other modification to the power from power source 636 to make the power suitable for the respective components of WD 610 to which power is supplied.

15 Figure 7 illustrates one embodiment of a UE in accordance with various aspects described herein. As used herein, a user equipment or UE may not necessarily have a user in the sense of a human user who owns and/or operates the relevant device. Instead, a UE may represent a device that is intended for sale to, or operation by, a human user but which may not, or which may not initially, be associated with a specific
20 human user (e.g., a smart sprinkler controller). Alternatively, a UE may represent a device that is not intended for sale to, or operation by, an end user but which may be associated with or operated for the benefit of a user (e.g., a smart power meter). UE 700 may be any UE identified by the 3rd Generation Partnership Project (3GPP), including a NB-IoT UE, a machine type communication (MTC) UE, and/or an enhanced
25 MTC (eMTC) UE. UE 700, as illustrated in Figure 7, is one example of a WD configured for communication in accordance with one or more communication standards promulgated by the 3rd Generation Partnership Project (3GPP), such as 3GPP's GSM, UMTS, LTE, and/or 5G standards. As mentioned previously, the term WD and UE may be used interchangeable. Accordingly, although Figure 7 is a UE, the
30 components discussed herein are equally applicable to a WD, and vice-versa. In Figure 7, UE 700 includes processing circuitry 701 that is operatively coupled to input/output interface 705, radio frequency (RF) interface 709, network connection interface 711, memory 715 including random access memory (RAM) 717, read-only memory (ROM) 719, and storage medium 721 or the like, communication subsystem
35 731, power source 733, and/or any other component, or any combination thereof. Storage medium 721 includes operating system 723, application program 725, and

data 727. In other embodiments, storage medium 721 may include other similar types of information. Certain UEs may utilize all of the components shown in Figure 7, or only a subset of the components. The level of integration between the components may vary from one UE to another UE. Further, certain UEs may contain multiple
5 instances of a component, such as multiple processors, memories, transceivers, transmitters, receivers, etc.

In Figure 7, processing circuitry 701 may be configured to process computer instructions and data. Processing circuitry 701 may be configured to implement any
10 sequential state machine operative to execute machine instructions stored as machine-readable computer programs in the memory, such as one or more hardware-implemented state machines (e.g., in discrete logic, FPGA, ASIC, etc.); programmable logic together with appropriate firmware; one or more stored program, general-purpose processors, such as a microprocessor or Digital Signal Processor (DSP), together with
15 appropriate software; or any combination of the above. For example, the processing circuitry 701 may include two central processing units (CPUs). Data may be information in a form suitable for use by a computer.

In the depicted embodiment, input/output interface 705 may be configured to provide a
20 communication interface to an input device, output device, or input and output device. UE 700 may be configured to use an output device via input/output interface 705. An output device may use the same type of interface port as an input device. For example, a USB port may be used to provide input to and output from UE 700. The output device may be a speaker, a sound card, a video card, a display, a monitor, a
25 printer, an actuator, an emitter, a smartcard, another output device, or any combination thereof. UE 700 may be configured to use an input device via input/output interface 705 to allow a user to capture information into UE 700. The input device may include a touch-sensitive or presence-sensitive display, a camera (e.g., a digital camera, a digital video camera, a web camera, etc.), a microphone, a sensor, a mouse, a trackball, a
30 directional pad, a trackpad, a scroll wheel, a smartcard, and the like. The presence-sensitive display may include a capacitive or resistive touch sensor to sense input from a user. A sensor may be, for instance, an accelerometer, a gyroscope, a tilt sensor, a force sensor, a magnetometer, an optical sensor, a proximity sensor, another like sensor, or any combination thereof. For example, the input device may be an
35 accelerometer, a magnetometer, a digital camera, a microphone, and an optical sensor.

In Figure 7, RF interface 709 may be configured to provide a communication interface to RF components such as a transmitter, a receiver, and an antenna. Network connection interface 711 may be configured to provide a communication interface to network 743a. Network 743a may encompass wired and/or wireless networks such as a local-area network (LAN), a wide-area network (WAN), a computer network, a wireless network, a telecommunications network, another like network or any combination thereof. For example, network 743a may comprise a Wi-Fi network. Network connection interface 711 may be configured to include a receiver and a transmitter interface used to communicate with one or more other devices over a communication network according to one or more communication protocols, such as Ethernet, TCP/IP, SONET, ATM, or the like. Network connection interface 711 may implement receiver and transmitter functionality appropriate to the communication network links (e.g., optical, electrical, and the like). The transmitter and receiver functions may share circuit components, software or firmware, or alternatively may be implemented separately.

RAM 717 may be configured to interface via bus 702 to processing circuitry 701 to provide storage or caching of data or computer instructions during the execution of software programs such as the operating system, application programs, and device drivers. ROM 719 may be configured to provide computer instructions or data to processing circuitry 701. For example, ROM 719 may be configured to store invariant low-level system code or data for basic system functions such as basic input and output (I/O), startup, or reception of keystrokes from a keyboard that are stored in a non-volatile memory. Storage medium 721 may be configured to include memory such as RAM, ROM, programmable read-only memory (PROM), erasable programmable read-only memory (EPROM), electrically erasable programmable read-only memory (EEPROM), magnetic disks, optical disks, floppy disks, hard disks, removable cartridges, or flash drives. In one example, storage medium 721 may be configured to include operating system 723, application program 725 such as a web browser application, a widget or gadget engine or another application, and data file 727. Storage medium 721 may store, for use by UE 700, any of a variety of various operating systems or combinations of operating systems.

Storage medium 721 may be configured to include a number of physical drive units, such as redundant array of independent disks (RAID), floppy disk drive, flash memory,

USB flash drive, external hard disk drive, thumb drive, pen drive, key drive, high-density digital versatile disc (HD-DVD) optical disc drive, internal hard disk drive, Blu-Ray optical disc drive, holographic digital data storage (HDDS) optical disc drive, external mini-dual in-line memory module (DIMM), synchronous dynamic random
5 access memory (SDRAM), external micro-DIMM SDRAM, smartcard memory such as a subscriber identity module or a removable user identity (SIM/RUIM) module, other memory, or any combination thereof. Storage medium 721 may allow UE 700 to access computer-executable instructions, application programs or the like, stored on transitory or non-transitory memory media, to off-load data, or to upload data. An
10 article of manufacture, such as one utilizing a communication system may be tangibly embodied in storage medium 721, which may comprise a device readable medium. In Figure 7, processing circuitry 701 may be configured to communicate with network 743b using communication subsystem 731. Network 743a and network 743b may be the same network or networks or different network or networks. Communication
15 subsystem 731 may be configured to include one or more transceivers used to communicate with network 743b. For example, communication subsystem 731 may be configured to include one or more transceivers used to communicate with one or more remote transceivers of another device capable of wireless communication such as another WD, UE, or base station of a Radio Access Network (RAN) according to one or
20 more communication protocols, such as IEEE 802.11, Code Division Multiplexing Access (CDMA), WCDMA, GSM, LTE, Universal Terrestrial Radio Access Network (UTRAN), WiMax, or the like. Each transceiver may include transmitter 733 and/or receiver 735 to implement transmitter or receiver functionality, respectively, appropriate to the RAN links (e.g., frequency allocations and the like). Further, transmitter 733 and
25 receiver 735 of each transceiver may share circuit components, software or firmware, or alternatively may be implemented separately.

In the illustrated embodiment, the communication functions of communication subsystem 731 may include data communication, voice communication, multimedia
30 communication, short-range communications such as Bluetooth, near-field communication, location-based communication such as the use of the global positioning system (GPS) to determine a location, another like communication function, or any combination thereof. For example, communication subsystem 731 may include cellular communication, Wi-Fi communication, Bluetooth communication, and GPS
35 communication. Network 743b may encompass wired and/or wireless networks such as a local-area network (LAN), a wide-area network (WAN), a computer network, a

wireless network, a telecommunications network, another like network or any combination thereof. For example, network 743b may be a cellular network, a Wi-Fi network, and/or a near-field network. Power source 713 may be configured to provide alternating current (AC) or direct current (DC) power to components of UE 700.

- 5 The features, benefits and/or functions described herein may be implemented in one of the components of UE 700 or partitioned across multiple components of UE 700. Further, the features, benefits, and/or functions described herein may be implemented in any combination of hardware, software or firmware. In one example, communication subsystem 731 may be configured to include any of the components described herein.
- 10 Further, processing circuitry 701 may be configured to communicate with any of such components over bus 702. In another example, any of such components may be represented by program instructions stored in memory that when executed by processing circuitry 701 perform the corresponding functions described herein. In another example, the functionality of any of such components may be partitioned
- 15 between processing circuitry 701 and communication subsystem 731. In another example, the non-computationally intensive functions of any of such components may be implemented in software or firmware and the computationally intensive functions may be implemented in hardware.
- 20 Figure 8 is a schematic block diagram illustrating a virtualization environment 800 in which functions implemented by some embodiments may be virtualized. In the present context, virtualizing means creating virtual versions of apparatuses or devices which may include virtualizing hardware platforms, storage devices and networking resources. As used herein, virtualization can be applied to a node (e.g., a virtualized
- 25 base station or a virtualized radio access node) or to a device (e.g., a UE, a wireless device or any other type of communication device) or components thereof and relates to an implementation in which at least a portion of the functionality is implemented as one or more virtual components (e.g., via one or more applications, components, functions, virtual machines or containers executing on one or more physical processing
- 30 nodes in one or more networks).

In some embodiments, some or all of the functions described herein may be implemented as virtual components executed by one or more virtual machines implemented in one or more virtual environments 800 hosted by one or more of

35 hardware nodes 830. Further, in embodiments in which the virtual node is not a radio

access node or does not require radio connectivity (e.g., a core network node), then the network node may be entirely virtualized.

The functions may be implemented by one or more applications 820 (which may
5 alternatively be called software instances, virtual appliances, network functions, virtual nodes, virtual network functions, etc.) operative to implement some of the features, functions, and/or benefits of some of the embodiments disclosed herein. Applications 820 are run in virtualization environment 800 which provides hardware 830 comprising processing circuitry 860 and memory 890. Memory 890 contains instructions 895
10 executable by processing circuitry 860 whereby application 820 is operative to provide one or more of the features, benefits, and/or functions disclosed herein.

Virtualization environment 800, comprises general-purpose or special-purpose network hardware devices 830 comprising a set of one or more processors or processing
15 circuitry 860, which may be commercial off-the-shelf (COTS) processors, dedicated Application Specific Integrated Circuits (ASICs), or any other type of processing circuitry including digital or analog hardware components or special purpose processors. Each hardware device may comprise memory 890-1 which may be non-persistent memory for temporarily storing instructions 895 or software executed by
20 processing circuitry 860. Each hardware device may comprise one or more network interface controllers (NICs) 870, also known as network interface cards, which include physical network interface 880. Each hardware device may also include non-transitory, persistent, machine-readable storage media 890-2 having stored therein software 895 and/or instructions executable by processing circuitry 860. Software 895 may include
25 any type of software including software for instantiating one or more virtualization layers 850 (also referred to as hypervisors), software to execute virtual machines 840 as well as software allowing it to execute functions, features and/or benefits described in relation with some embodiments described herein.

30 Virtual machines 840, comprise virtual processing, virtual memory, virtual networking or interface and virtual storage, and may be run by a corresponding virtualization layer 850 or hypervisor. Different embodiments of the instance of virtual appliance 820 may be implemented on one or more of virtual machines 840, and the implementations may be made in different ways.

During operation, processing circuitry 860 executes software 895 to instantiate the hypervisor or virtualization layer 850, which may sometimes be referred to as a virtual machine monitor (VMM). Virtualization layer 850 may present a virtual operating platform that appears like networking hardware to virtual machine 840.

5

As shown in Figure 8, hardware 830 may be a standalone network node with generic or specific components. Hardware 830 may comprise antenna 8225 and may implement some functions via virtualization. Alternatively, hardware 830 may be part of a larger cluster of hardware (e.g. such as in a data center or customer premise equipment (CPE)) where many hardware nodes work together and are managed via management and orchestration (MANO) 8100, which, among others, oversees lifecycle management of applications 820.

10

Virtualization of the hardware is in some contexts referred to as network function virtualization (NFV). NFV may be used to consolidate many network equipment types onto industry standard high volume server hardware, physical switches, and physical storage, which can be located in data centers, and customer premise equipment. In the context of NFV, virtual machine 840 may be a software implementation of a physical machine that runs programs as if they were executing on a physical, non-

20 virtualized machine. Each of virtual machines 840, and that part of hardware 830 that executes that virtual machine, be it hardware dedicated to that virtual machine and/or hardware shared by that virtual machine with others of the virtual machines 840, forms a separate virtual network elements (VNE).

15

20

25 Still in the context of NFV, Virtual Network Function (VNF) is responsible for handling specific network functions that run in one or more virtual machines 840 on top of hardware networking infrastructure 830 and corresponds to application 820 in Figure 8. In some embodiments, one or more radio units 8200 that each include one or more transmitters 8220 and one or more receivers 8210 may be coupled to one or more

30 antennas 8225. Radio units 8200 may communicate directly with hardware nodes 830 via one or more appropriate network interfaces and may be used in combination with the virtual components to provide a virtual node with radio capabilities, such as a radio access node or a base station.

30

In some embodiments, some signalling can be effected with the use of control system 8230 which may alternatively be used for communication between the hardware nodes 830 and radio units 8200.

5 Figure 9 shows a telecommunication network connected via an intermediate network to a host computer in accordance with some embodiments. Specifically, in accordance with an embodiment, a communication system includes telecommunication network 910, such as a 3GPP-type cellular network, which comprises access network 911, such as a radio access network, and core network 914. Access network 911 comprises a
10 plurality of base stations 912a, 912b, 912c, such as NBs, eNBs, gNBs or other types of wireless access points, each defining a corresponding coverage area 913a, 913b, 913c. Each base station 912a, 912b, 912c is connectable to core network 914 over a wired or wireless connection 915. A first UE 991 located in coverage area 913c is configured to wirelessly connect to, or be paged by, the corresponding base station
15 912c. A second UE 992 in coverage area 913a is wirelessly connectable to the corresponding base station 912a. While a plurality of UEs 991, 992 are illustrated in this example, the disclosed embodiments are equally applicable to a situation where a sole UE is in the coverage area or where a sole UE is connecting to the corresponding base station 912.

20

Telecommunication network 910 is itself connected to host computer 930, which may be embodied in the hardware and/or software of a standalone server, a cloud-implemented server, a distributed server or as processing resources in a server farm. Host computer 930 may be under the ownership or control of a service provider, or
25 may be operated by the service provider or on behalf of the service provider. Connections 921 and 922 between telecommunication network 910 and host computer 930 may extend directly from core network 914 to host computer 930 or may go via an optional intermediate network 920. Intermediate network 920 may be one of, or a combination of more than one of, a public, private or hosted network; intermediate
30 network 920, if any, may be a backbone network or the Internet; in particular, intermediate network 920 may comprise two or more sub-networks (not shown). The communication system of Figure 9 as a whole enables connectivity between the connected UEs 991, 992 and host computer 930. The connectivity may be described as an over-the-top (OTT) connection 950. Host computer 930 and the connected UEs
35 991, 992 are configured to communicate data and/or signalling via OTT connection 950, using access network 911, core network 914, any intermediate network 920 and

possible further infrastructure (not shown) as intermediaries. OTT connection 950 may be transparent in the sense that the participating communication devices through which OTT connection 950 passes are unaware of routing of uplink and downlink communications. For example, base station 912 may not or need not be informed about the past routing of an incoming downlink communication with data originating from host computer 930 to be forwarded (e.g., handed over) to a connected UE 991. Similarly, base station 912 need not be aware of the future routing of an outgoing uplink communication originating from the UE 991 towards the host computer 930.

Figure 10 shows a host computer communicating via a base station with a user equipment over a partially wireless connection in accordance with some embodiments. Example implementations, in accordance with an embodiment, of the UE, base station and host computer discussed in the preceding paragraphs will now be described with reference to Figure 10. In communication system 1000, host computer 1010 comprises hardware 1015 including communication interface 1016 configured to set up and maintain a wired or wireless connection with an interface of a different communication device of communication system 1000. Host computer 1010 further comprises processing circuitry 1018, which may have storage and/or processing capabilities. In particular, processing circuitry 1018 may comprise one or more programmable processors, application-specific integrated circuits, field programmable gate arrays or combinations of these (not shown) adapted to execute instructions. Host computer 1010 further comprises software 1011, which is stored in or accessible by host computer 1010 and executable by processing circuitry 1018. Software 1011 includes host application 1012. Host application 1012 may be operable to provide a service to a remote user, such as UE 1030 connecting via OTT connection 1050 terminating at UE 1030 and host computer 1010. In providing the service to the remote user, host application 1012 may provide user data which is transmitted using OTT connection 1050.

Communication system 1000 further includes base station 1020 provided in a telecommunication system and comprising hardware 1025 enabling it to communicate with host computer 1010 and with UE 1030. Hardware 1025 may include communication interface 1026 for setting up and maintaining a wired or wireless connection with an interface of a different communication device of communication system 1000, as well as radio interface 1027 for setting up and maintaining at least wireless connection 1070 with UE 1030 located in a coverage area (not shown in

Figure 10) served by base station 1020. Communication interface 1026 may be configured to facilitate connection 1060 to host computer 1010. Connection 1060 may be direct or it may pass through a core network (not shown in Figure 10) of the telecommunication system and/or through one or more intermediate networks outside
5 the telecommunication system. In the embodiment shown, hardware 1025 of base station 1020 further includes processing circuitry 1028, which may comprise one or more programmable processors, application-specific integrated circuits, field programmable gate arrays or combinations of these (not shown) adapted to execute instructions. Base station 1020 further has software 1021 stored internally or
10 accessible via an external connection.

Communication system 1000 further includes UE 1030 already referred to. Its hardware 1035 may include radio interface 1037 configured to set up and maintain wireless connection 1070 with a base station serving a coverage area in which UE
15 1030 is currently located. Hardware 1035 of UE 1030 further includes processing circuitry 1038, which may comprise one or more programmable processors, application-specific integrated circuits, field programmable gate arrays or combinations of these (not shown) adapted to execute instructions. UE 1030 further comprises software 1031, which is stored in or accessible by UE 1030 and executable by
20 processing circuitry 1038. Software 1031 includes client application 1032. Client application 1032 may be operable to provide a service to a human or non-human user via UE 1030, with the support of host computer 1010. In host computer 1010, an executing host application 1012 may communicate with the executing client application 1032 via OTT connection 1050 terminating at UE 1030 and host computer 1010. In
25 providing the service to the user, client application 1032 may receive request data from host application 1012 and provide user data in response to the request data. OTT connection 1050 may transfer both the request data and the user data. Client application 1032 may interact with the user to generate the user data that it provides. It is noted that host computer 1010, base station 1020 and UE 1030 illustrated in
30 Figure 10 may be similar or identical to host computer 930, one of base stations 912a, 912b, 912c and one of UEs 991, 992 of Figure 9, respectively. This is to say, the inner workings of these entities may be as shown in Figure 10 and independently, the surrounding network topology may be that of Figure 9.

35 In Figure 10, OTT connection 1050 has been drawn abstractly to illustrate the communication between host computer 1010 and UE 1030 via base station 1020,

without explicit reference to any intermediary devices and the precise routing of messages via these devices. Network infrastructure may determine the routing, which it may be configured to hide from UE 1030 or from the service provider operating host computer 1010, or both. While OTT connection 1050 is active, the network
5 infrastructure may further take decisions by which it dynamically changes the routing (e.g., on the basis of load balancing consideration or reconfiguration of the network). Wireless connection 1070 between UE 1030 and base station 1020 is in accordance with the teachings of the embodiments described throughout this disclosure. One or more of the various embodiments improve the performance of OTT services provided
10 to UE 1030 using OTT connection 1050, in which wireless connection 1070 forms the last segment. More precisely, the teachings of these embodiments may improve the data rate, latency, and/or power consumption, and thereby provide benefits such as reduced user waiting time, relaxed restriction on file size, better responsiveness, and/or extended battery lifetime.

15 A measurement procedure may be provided for the purpose of monitoring data rate, latency and other factors on which the one or more embodiments improve. There may further be an optional network functionality for reconfiguring OTT connection 1050 between host computer 1010 and UE 1030, in response to variations in the
20 measurement results. The measurement procedure and/or the network functionality for reconfiguring OTT connection 1050 may be implemented in software 1011 and hardware 1015 of host computer 1010 or in software 1031 and hardware 1035 of UE 1030, or both. In embodiments, sensors (not shown) may be deployed in or in association with communication devices through which OTT connection 1050 passes;
25 the sensors may participate in the measurement procedure by supplying values of the monitored quantities exemplified above, or supplying values of other physical quantities from which software 1011, 1031 may compute or estimate the monitored quantities. The reconfiguring of OTT connection 1050 may include message format, retransmission settings, preferred routing etc.; the reconfiguring need not affect base
30 station 1020, and it may be unknown or imperceptible to base station 1020. Such procedures and functionalities may be known and practiced in the art. In certain embodiments, measurements may involve proprietary UE signaling facilitating host computer 1010's measurements of throughput, propagation times, latency and the like. The measurements may be implemented in that software 1011 and 1031 causes
35 messages to be transmitted, in particular empty or 'dummy' messages, using OTT connection 1050 while it monitors propagation times, errors etc.

Figure 11 is a flowchart illustrating a method implemented in a communication system, in accordance with one embodiment. The communication system includes a host computer, a base station and a UE which may be those described with reference to
5 Figures 9 and 10. For simplicity of the present disclosure, only drawing references to Figure 11 will be included in this section. In step 1110, the host computer provides user data. In substep 1111 (which may be optional) of step 1110, the host computer provides the user data by executing a host application. In step 1120, the host
10 computer initiates a transmission carrying the user data to the UE. In step 1130 (which may be optional), the base station transmits to the UE the user data which was carried in the transmission that the host computer initiated, in accordance with the teachings of the embodiments described throughout this disclosure. In step 1140 (which may also be optional), the UE executes a client application associated with the host application executed by the host computer.

15

Figure 12 is a flowchart illustrating a method implemented in a communication system, in accordance with one embodiment. The communication system includes a host computer, a base station and a UE which may be those described with reference to
20 Figures 9 and 10. For simplicity of the present disclosure, only drawing references to Figure 12 will be included in this section. In step 1210 of the method, the host computer provides user data. In an optional substep (not shown) the host computer provides the user data by executing a host application. In step 1220, the host computer initiates a transmission carrying the user data to the UE. The transmission may pass via the base station, in accordance with the teachings of the embodiments described throughout this
25 disclosure. In step 1230 (which may be optional), the UE receives the user data carried in the transmission.

Figure 13 is a flowchart illustrating a method implemented in a communication system, in accordance with one embodiment. The communication system includes a host
30 computer, a base station and a UE which may be those described with reference to Figures 9 and 10. For simplicity of the present disclosure, only drawing references to Figure 13 will be included in this section. In step 1310 (which may be optional), the UE receives input data provided by the host computer. Additionally or alternatively, in step 1320, the UE provides user data. In substep 1321 (which may be optional) of step
35 1320, the UE provides the user data by executing a client application. In substep 1311 (which may be optional) of step 1310, the UE executes a client application which

provides the user data in reaction to the received input data provided by the host computer. In providing the user data, the executed client application may further consider user input received from the user. Regardless of the specific manner in which the user data was provided, the UE initiates, in substep 1330 (which may be optional),
5 transmission of the user data to the host computer. In step 1340 of the method, the host computer receives the user data transmitted from the UE, in accordance with the teachings of the embodiments described throughout this disclosure.

Figure 14 is a flowchart illustrating a method implemented in a communication system,
10 in accordance with one embodiment. The communication system includes a host computer, a base station and a UE which may be those described with reference to Figures 9 and 10. For simplicity of the present disclosure, only drawing references to Figure 14 will be included in this section. In step 1410 (which may be optional), in accordance with the teachings of the embodiments described throughout this
15 disclosure, the base station receives user data from the UE. In step 1420 (which may be optional), the base station initiates transmission of the received user data to the host computer. In step 1430 (which may be optional), the host computer receives the user data carried in the transmission initiated by the base station.

20 Any appropriate steps, methods, features, functions, or benefits disclosed herein may be performed through one or more functional units or modules of one or more virtual apparatuses. Each virtual apparatus may comprise a number of these functional units. These functional units may be implemented via processing circuitry, which may include one or more microprocessor or microcontrollers, as well as other digital hardware,
25 which may include digital signal processors (DSPs), special-purpose digital logic, and the like. The processing circuitry may be configured to execute program code stored in memory, which may include one or several types of memory such as read-only memory (ROM), random-access memory (RAM), cache memory, flash memory devices, optical storage devices, etc. Program code stored in memory includes
30 program instructions for executing one or more telecommunications and/or data communications protocols as well as instructions for carrying out one or more of the techniques described herein. In some implementations, the processing circuitry may be used to cause the respective functional unit to perform corresponding functions according one or more embodiments of the present disclosure.

35

Figure 15 illustrates a schematic block diagram of an apparatus 1500 in a wireless network (for example, the wireless network shown in Figure 6). The apparatus may be implemented in a wireless device or network node (e.g., wireless device 610 or network node 660 shown in Figure 6). Apparatus 1500 is operable to carry out the example method described with reference to Figure 4 and possibly any other processes or methods disclosed herein. It is also to be understood that the method of Figure 4 is not necessarily carried out solely by apparatus 1500. At least some operations of the method can be performed by one or more other entities.

Virtual Apparatus 1500 may comprise processing circuitry, which may include one or more microprocessor or microcontrollers, as well as other digital hardware, which may include digital signal processors (DSPs), special-purpose digital logic, and the like. The processing circuitry may be configured to execute program code stored in memory, which may include one or several types of memory such as read-only memory (ROM), random-access memory, cache memory, flash memory devices, optical storage devices, etc. Program code stored in memory includes program instructions for executing one or more telecommunications and/or data communications protocols as well as instructions for carrying out one or more of the techniques described herein, in several embodiments. In some implementations, the processing circuitry may be used to cause selecting unit 1502 and transmitting unit 1504, and any other suitable units of apparatus 1500 to perform corresponding functions according one or more embodiments of the present disclosure.

As illustrated in Figure 15, apparatus 1500 includes selecting unit 1502 and transmitting unit 1504. Selecting unit 1502 is configured to select one random access resource from a plurality of available random access resources, when indicated to do so by a paging transmission received by the wireless device. For example, the selecting unit 1502 may randomly select a random access resource. Transmitting unit 1504 is configured to transmit a random access preamble using the selected random access resource.

Figure 16 illustrates a schematic block diagram of an apparatus 1600 in a wireless network (for example, the wireless network shown in Figure 6). The apparatus may be implemented in a network node (e.g., network node 660 shown in Figure 6). Apparatus 1600 is operable to carry out the example method described with reference to Figure 3 and possibly any other processes or methods disclosed herein. It is also to be

understood that the method of Figure 3 is not necessarily carried out solely by apparatus 1600. At least some operations of the method can be performed by one or more other entities.

5 1600 may comprise processing circuitry, which may include one or more microprocessor or microcontrollers, as well as other digital hardware, which may include digital signal processors (DSPs), special-purpose digital logic, and the like. The processing circuitry may be configured to execute program code stored in memory, which may include one or several types of memory such as read-only
10 memory (ROM), random-access memory, cache memory, flash memory devices, optical storage devices, etc. Program code stored in memory includes program instructions for executing one or more telecommunications and/or data communications protocols as well as instructions for carrying out one or more of the techniques described herein, in several embodiments. In some implementations, the
15 processing circuitry may be used to cause transmitting unit 1602, and any other suitable units of apparatus 1600 to perform corresponding functions according one or more embodiments of the present disclosure.

As illustrated in Figure 16, apparatus 1600 includes transmitting unit 1602, which is
20 configured to cause a paging transmission to be transmitted to the wireless device, wherein the paging transmission causes the wireless device to select one random access resource from a plurality of available random access resources. The term unit may have conventional meaning in the field of electronics, electrical devices and/or electronic devices and may include, for example, electrical and/or
25 electronic circuitry, devices, modules, processors, memories, logic solid state and/or discrete devices, computer programs or instructions for carrying out respective tasks, procedures, computations, outputs, and/or displaying functions, and so on, as such as those that are described herein.

CLAIMS

1. A method performed by a wireless device for performing a random access, the method comprising:
 - 5 in response to a received paging transmission (402), randomly selecting (404) one random access resource from a plurality of available random access resources spread in time; and
 - transmitting (406) a random access signal on the selected random access resource.
- 10 2. The method of claim 1, wherein the random access signal comprises a random access preamble.
3. The method of claim 1 or 2, comprising randomly selecting one random access resource from the plurality of available random access resources spread in time in the event that a predetermined condition is met.
- 15 4. The method of claim 3, wherein randomly selecting one random access resource from a plurality of available random access resources comprises:
 - 20 determining a number of wireless devices that have received the paging transmission; and
 - randomly selecting one random access resource from the plurality of available random access resources spread in time, if it is determined that the number of wireless devices that have received the paging transmission exceeds a threshold number.
- 25 5. The method of claim 4, comprising determining the number of wireless devices that have received the paging transmission from a number of paging records in a Physical Downlink Shared Channel message.
- 30 6. The method of claim 4, comprising determining the number of wireless devices that have received the paging transmission from a length of a paging message on a Physical Downlink Shared Channel.
7. The method of one of claims 1 to 6, wherein randomly selecting one random access resource from a plurality of available random access resources spread in time
- 35

comprises waiting for a random time before attempting to transmit the random access signal.

8. The method of claim 7, wherein the random time is selected from within a time interval defined by a starting time and by an interval length, and wherein the starting time and the interval length are determined based on at least one of: the paging configuration, the Physical Random Access Channel, PRACH, configuration, the paging load, the random-access load, the coverage enhancement, CE, level of the device, or the CE level used for the Physical Downlink Control Channel, PDCCH, scrambled by the Paging Radio Network Temporary Identifier, P-RNTI, transmission.

9. The method of any of the previous claims, comprising randomly selecting one random access resource from a plurality of available random access resources spread in time in response to receiving a paging transmission in which a Downlink Control Indicator carried by the Physical Downlink Control CHannel signals that the wireless device should randomly select one random access resource from the plurality of available random access resources spread in time.

10. The method of any of the previous claims, wherein randomly selecting one random access resource from the plurality of available random access resources spread in time comprises:

when the received paging transmission comprises a control channel message having a Cyclic Redundancy Code scrambled by a first identifier, selecting a predetermined random access resource of the plurality of available random access resources spread in time; and

when the received paging transmission comprises a control channel message having a Cyclic Redundancy Code scrambled by a second identifier, randomly selecting a random access resource from the plurality of available random access resources spread in time.

11. The method of claim 10, wherein the control channel comprises a Physical Downlink Control Channel.

12. The method of claim 10 or 11, wherein the identifier comprises a Paging Radio Network Temporary Identifier.

13. The method of any of claims 1 to 8, comprising randomly selecting one random access resource from a plurality of available random access resources spread in time in response to receiving a paging transmission in which a Physical Downlink Shared CHannel contains an indication that said wireless device should randomly select one
5 random access resource from the plurality of available random access resources spread in time.

14. A method performed by a base station for configuring a random access by a wireless device, the method comprising:
10 causing a paging transmission to be transmitted to the wireless device (302), wherein the paging transmission causes the wireless device to randomly select one random access resource from a plurality of available random access resources spread in time.

15 15. The method of claim 14, further comprising receiving a random access signal from the wireless device on the selected random access resource.

16. The method of any of claims 14 and 15, wherein the paging transmission includes a Downlink Control Indicator carried by the Physical Downlink Control
20 Channel, indicating that the wireless device should randomly select one random access resource from the plurality of available random access resources spread in time.

17. The method of any of claims 14 to 16, comprising:
25 causing a paging transmission to be transmitted to the wireless device, comprising a control channel message having a Cyclic Redundancy Code scrambled by a first identifier, in order to cause the wireless device to select a predetermined random access resource of the plurality of available random access resources spread in time; and

30 causing a paging transmission to be transmitted to the wireless device, comprising a control channel message having a Cyclic Redundancy Code scrambled by a second identifier, in order to cause the wireless device to randomly select one random access resource from the plurality of available random access resources spread in time.

35

18. The method of claim 17, wherein the control channel comprises a Physical Downlink Control Channel.
19. The method of claim 17 or 18, wherein the identifier comprises a Paging Radio
5 Network Temporary Identifier.
20. The method of any of claims 14 and 15, wherein the paging transmission includes a Physical Downlink Shared CHannel containing an indication that said wireless device should select one random access resource from the plurality of
10 available random access resources spread in time.
21. A wireless device, configured to perform a method according to claim 1.
22. A wireless device according to claim 21, further configured to perform a method
15 according to any of claims 2 to 13.
23. A wireless device, the wireless device comprising:
processing circuitry configured to perform any of the steps of any of claims 1 to
13; and
20 power supply circuitry configured to supply power to the wireless device.
24. A base station, configured to perform a method according to claim 14.
25. A base station according to claim 24, further configured to perform a method
25 according to any of claims 15 to 20.
26. A base station, the base station comprising:
processing circuitry configured to perform any of the steps of any of claims 14 to
20; and
30 – power supply circuitry configured to supply power to the base station.

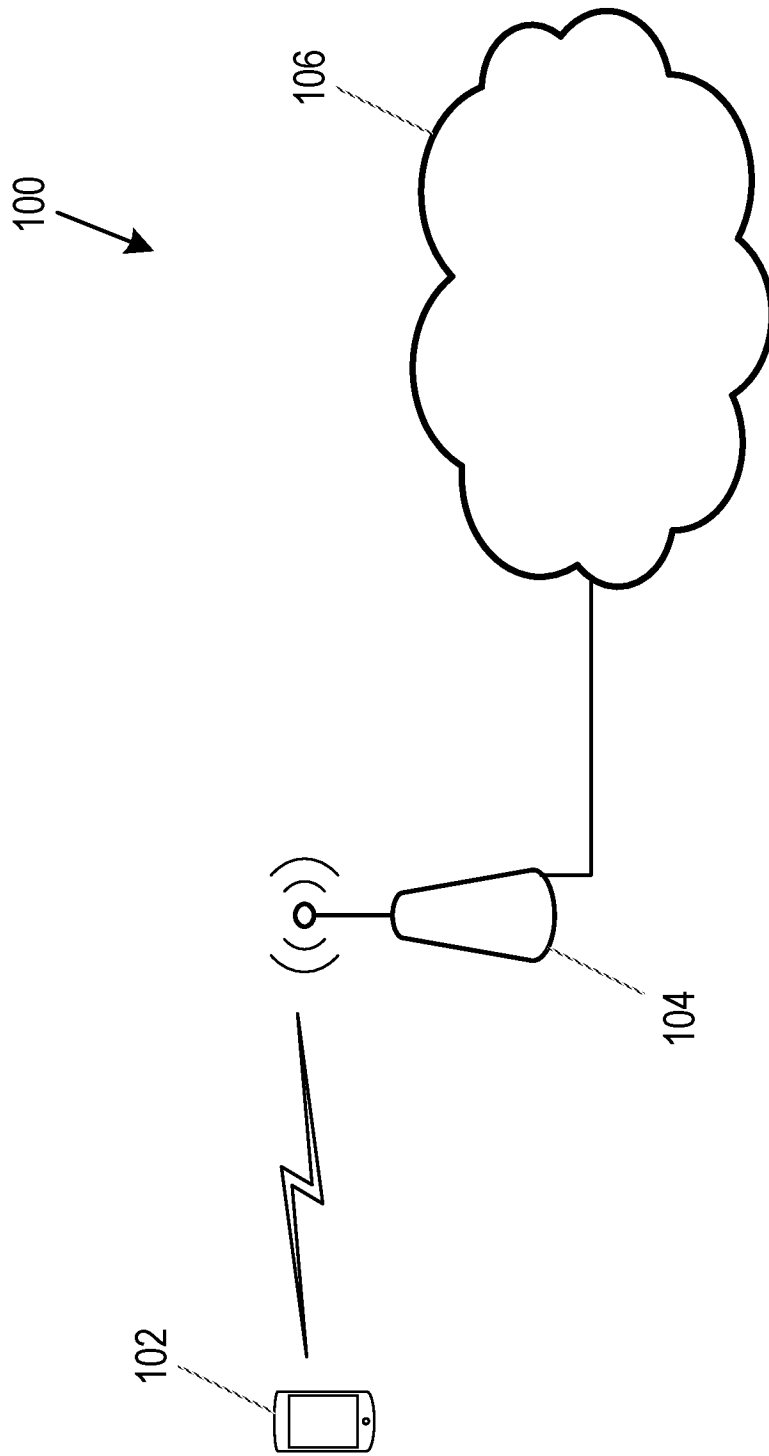

Fig. 1

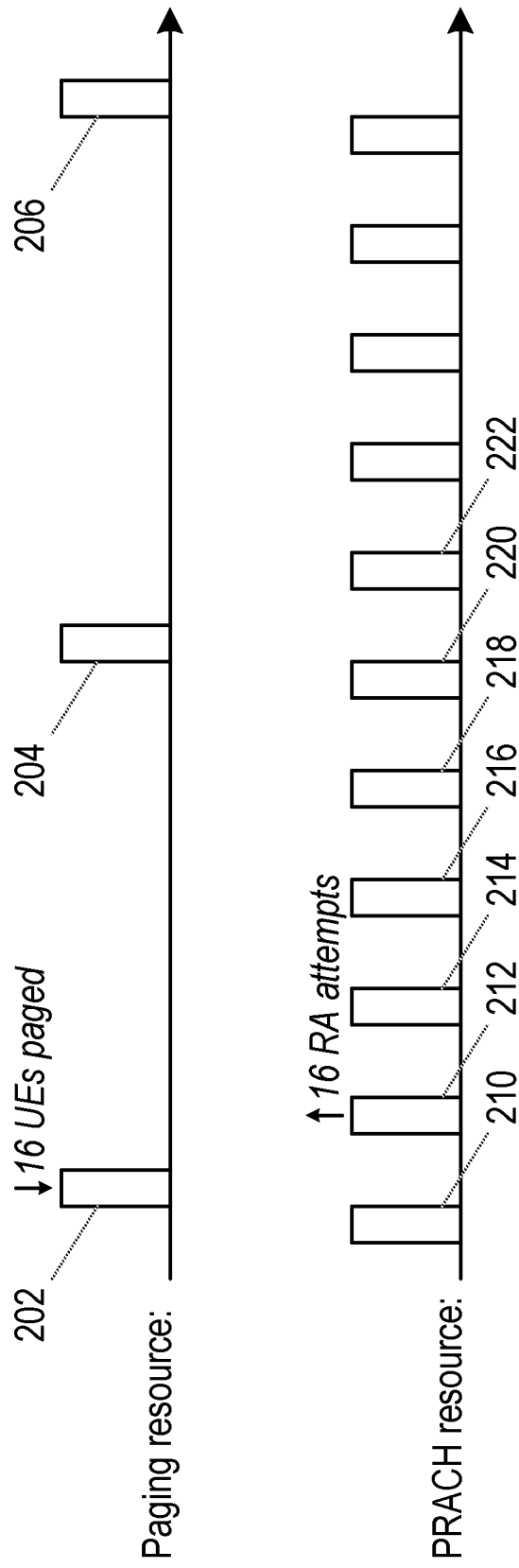

Fig. 2

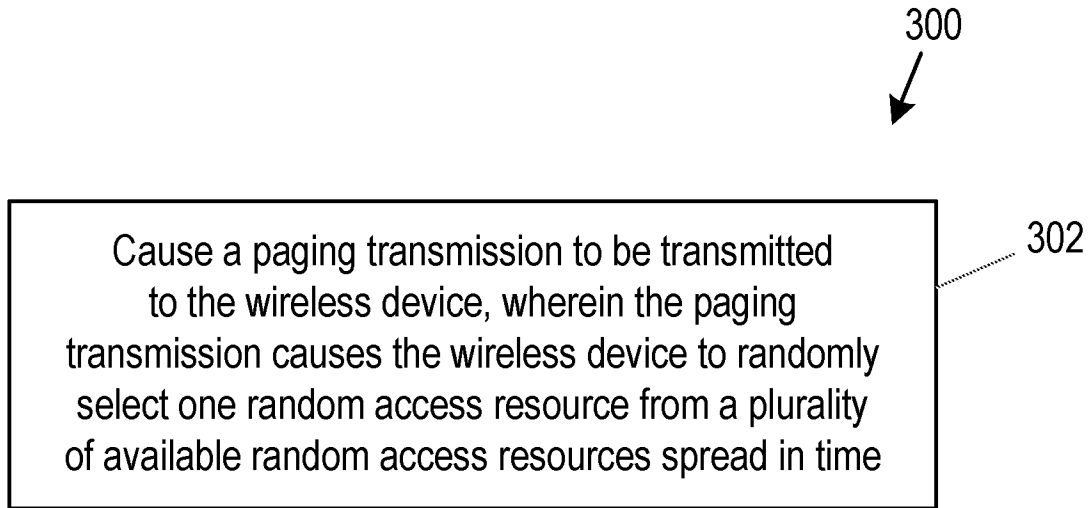

Fig. 3

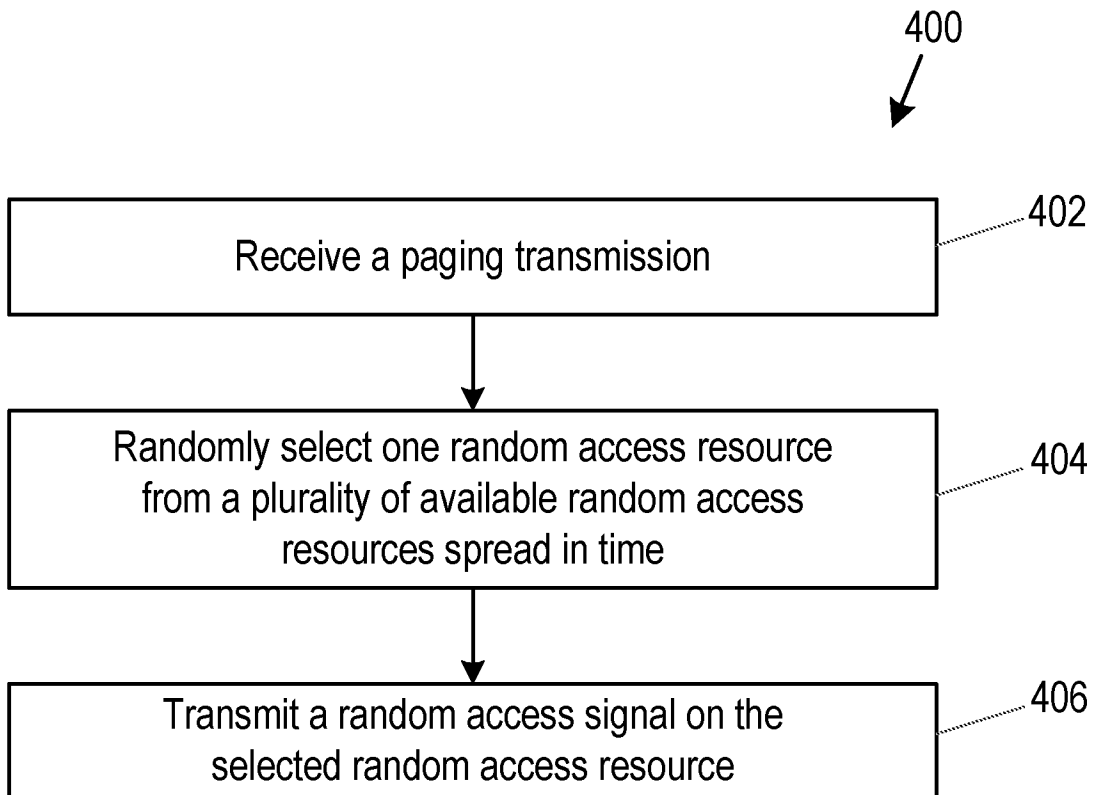

Fig. 4

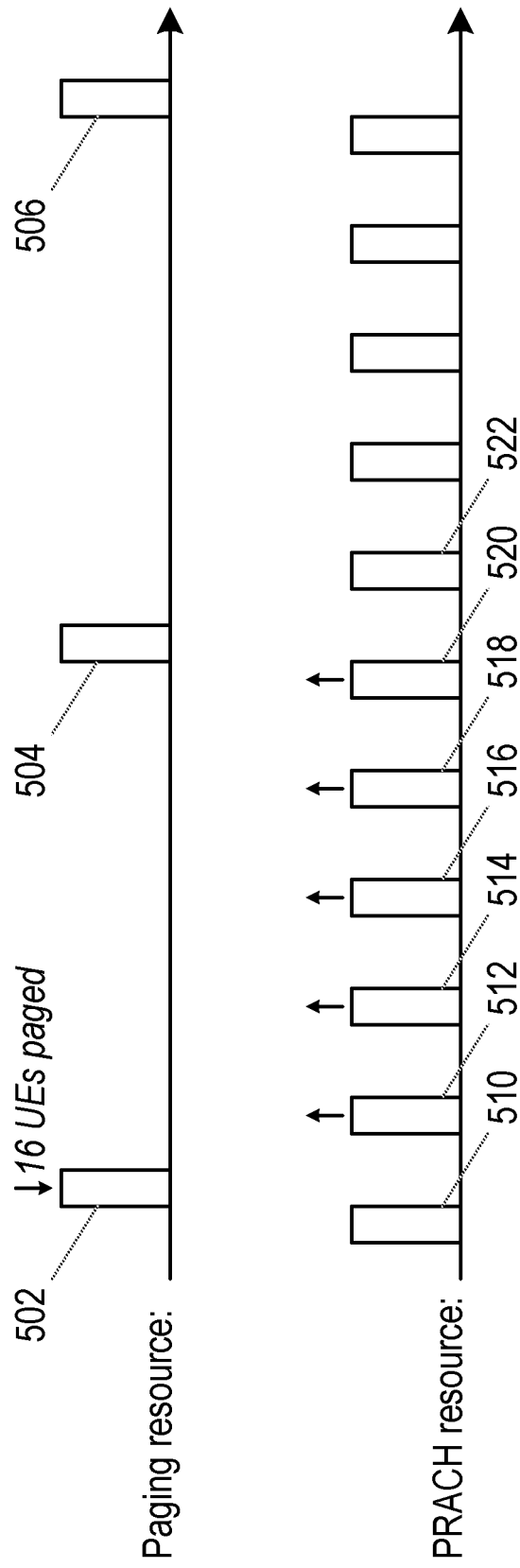

Fig. 5

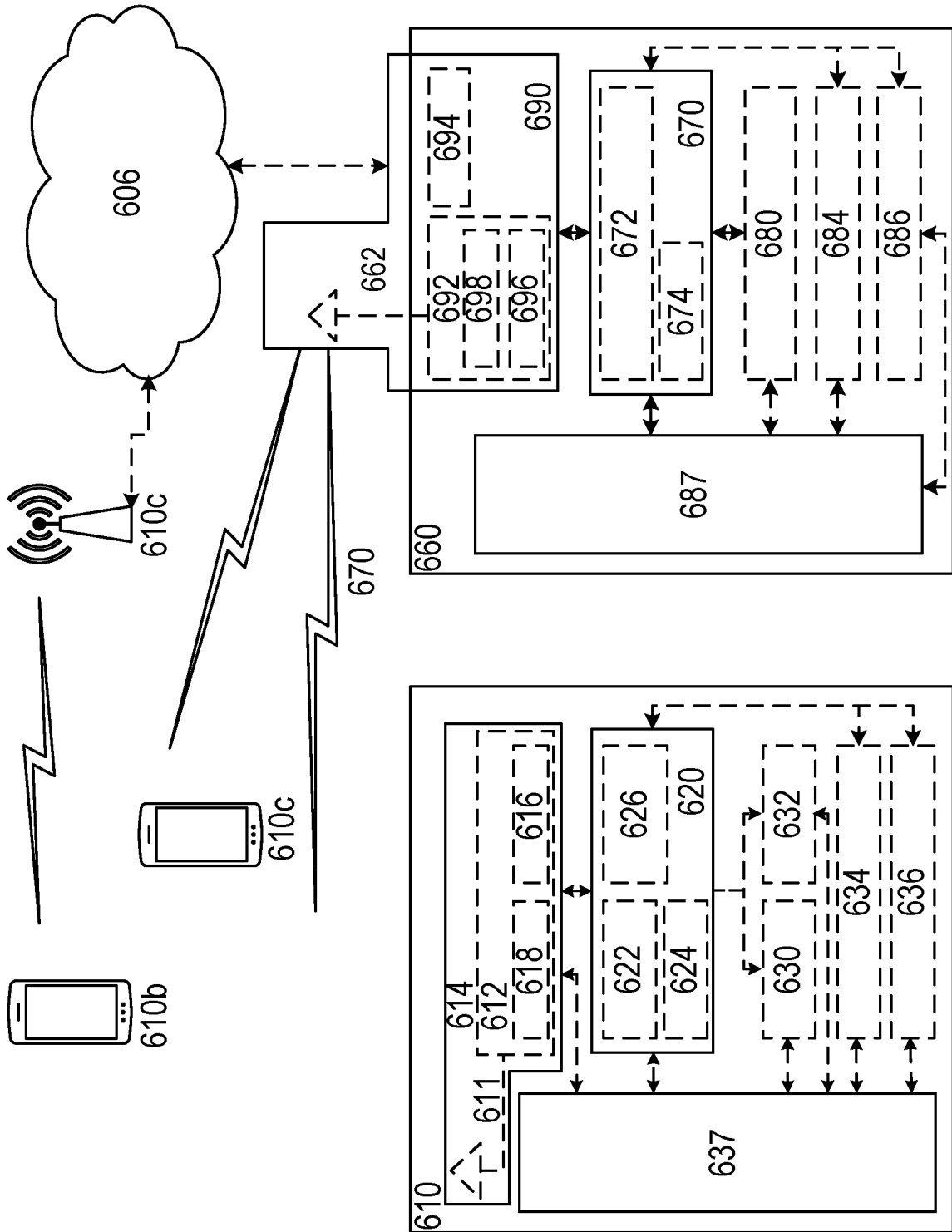

Fig. 6

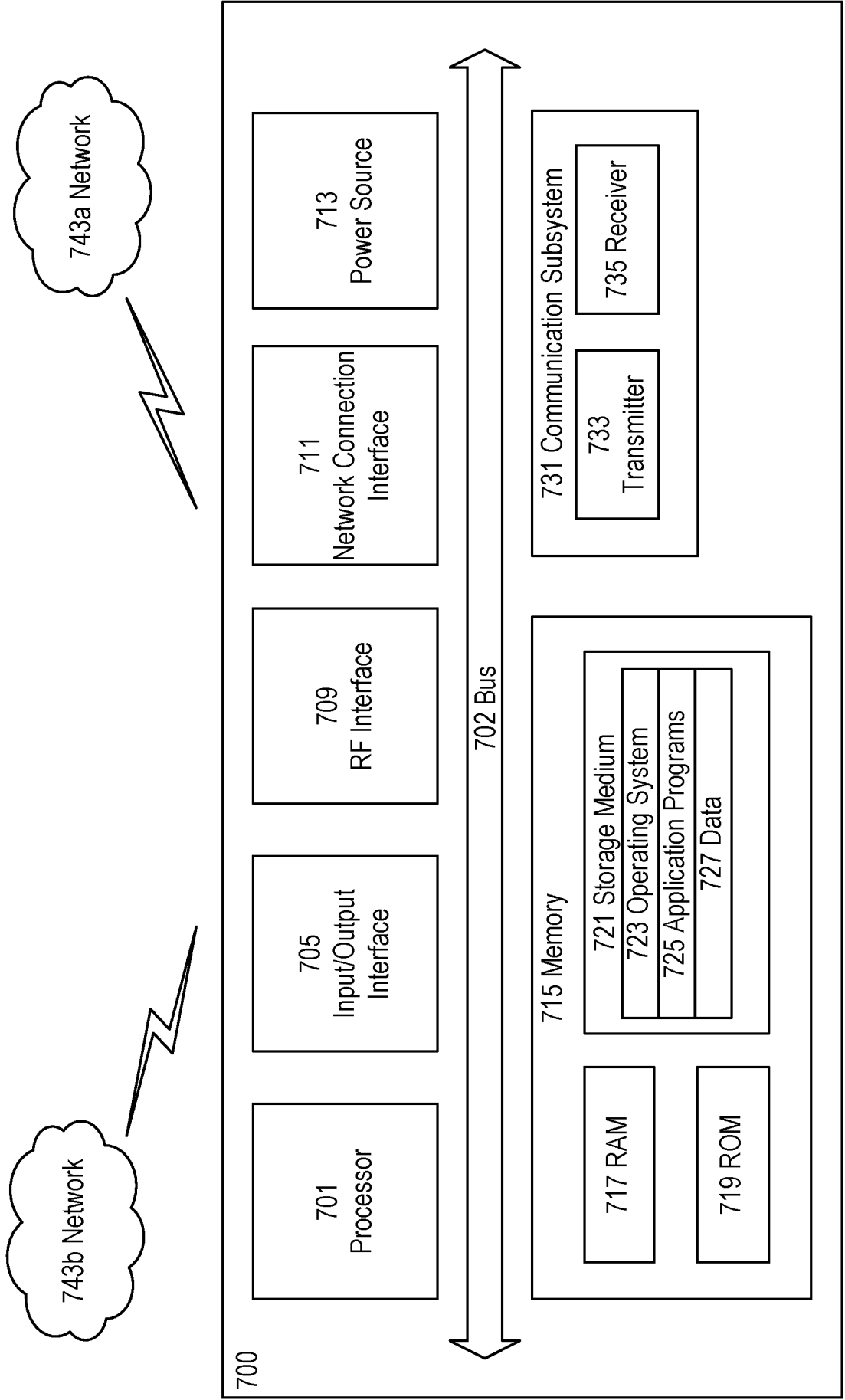

Fig. 7

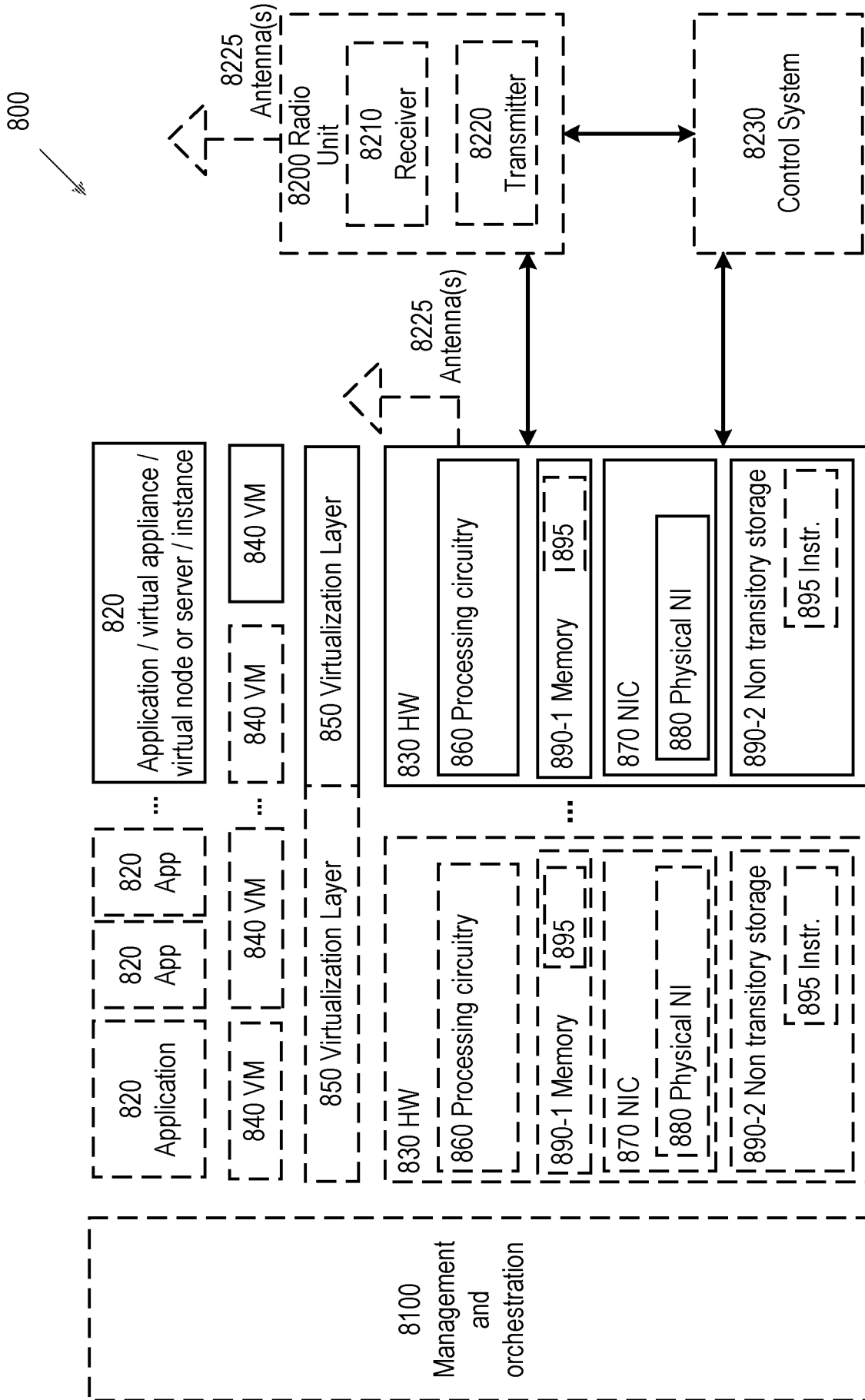

Fig. 8

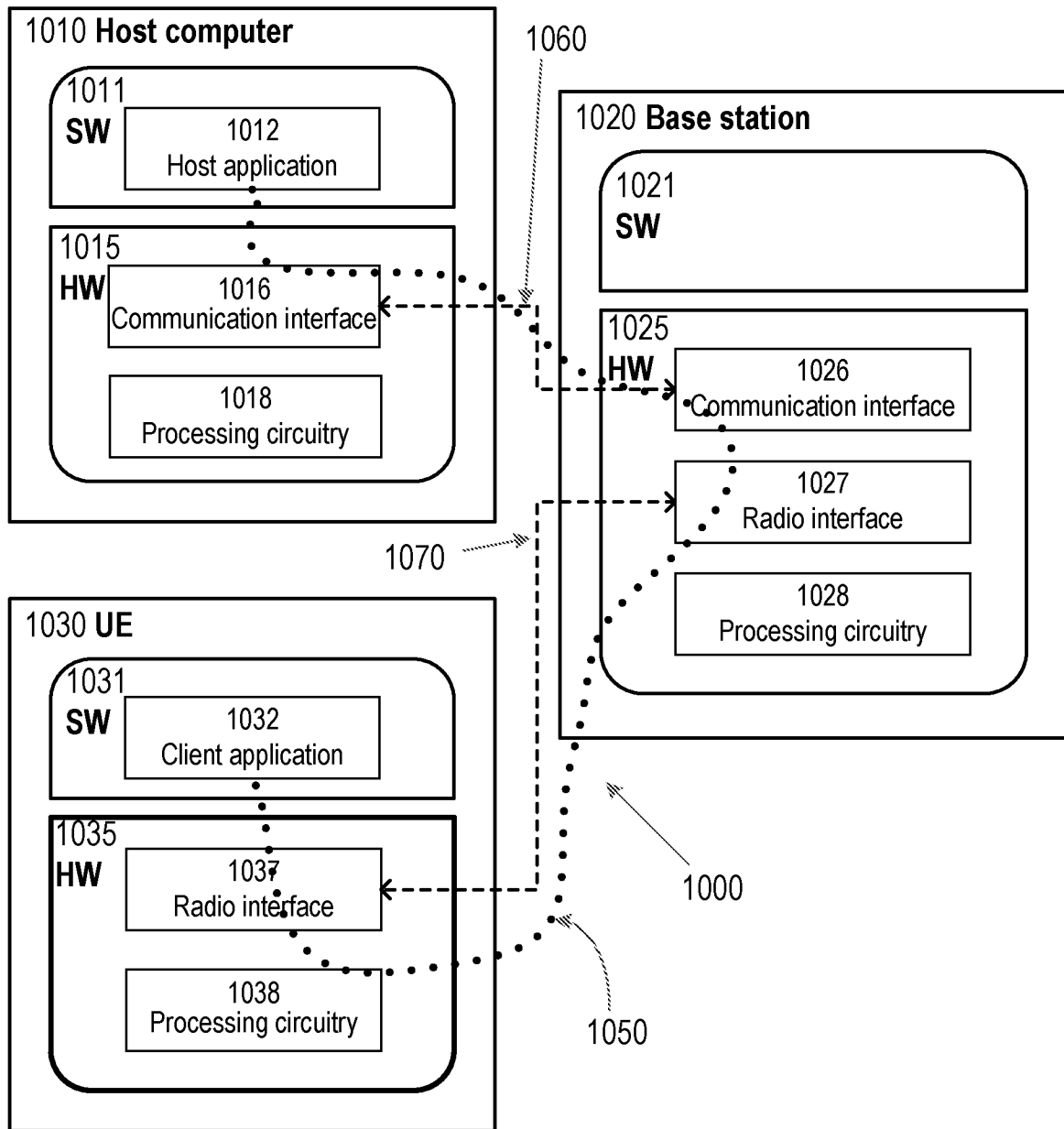

Fig. 10

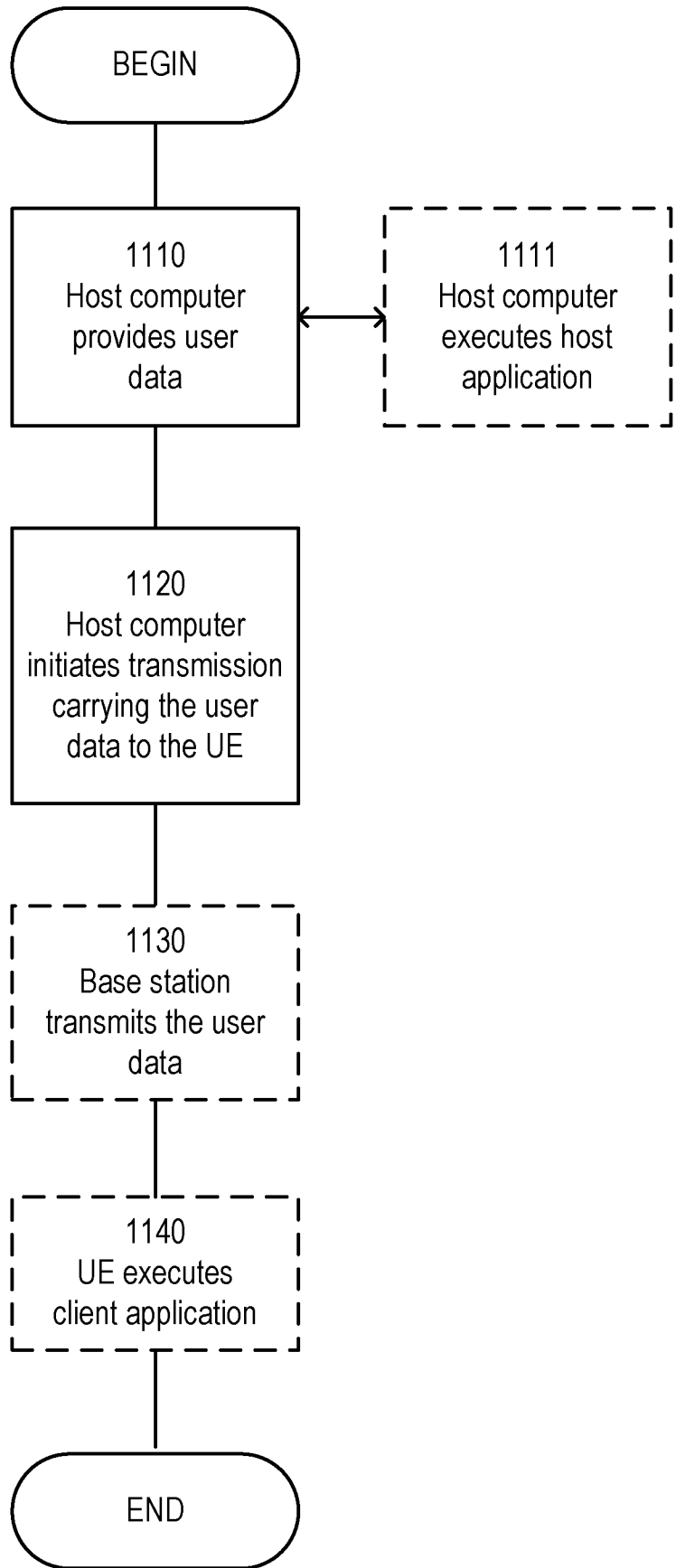

Fig. 11

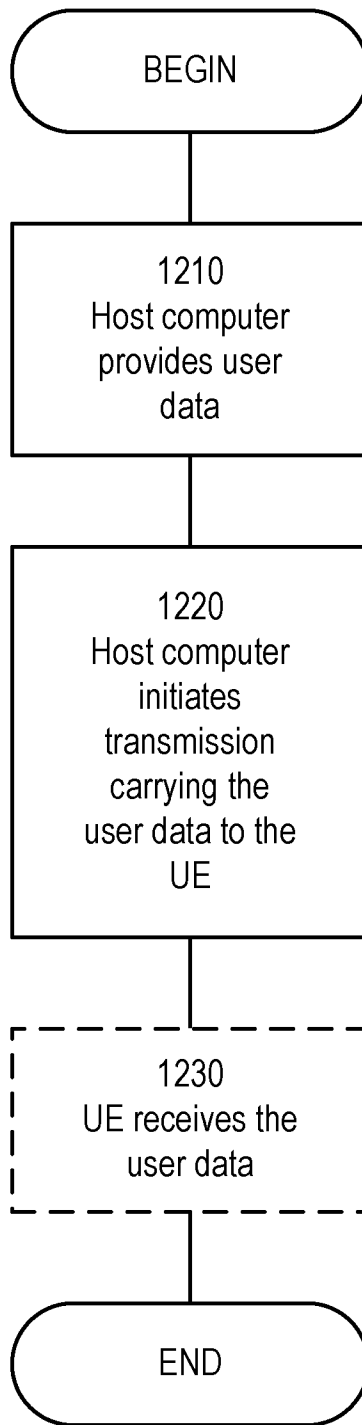

Fig. 12

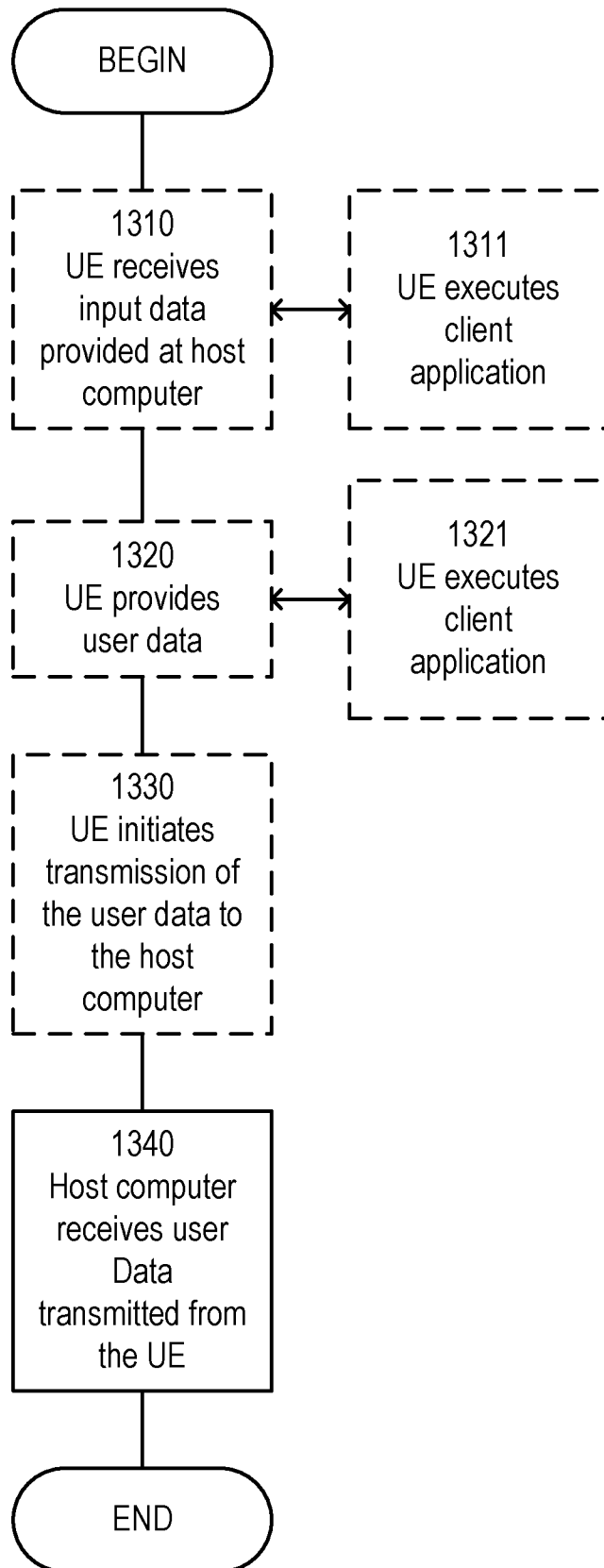

Fig. 13

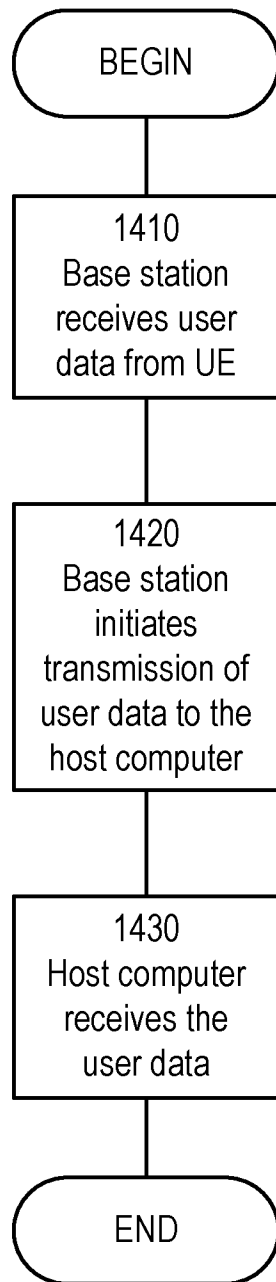

Fig. 14

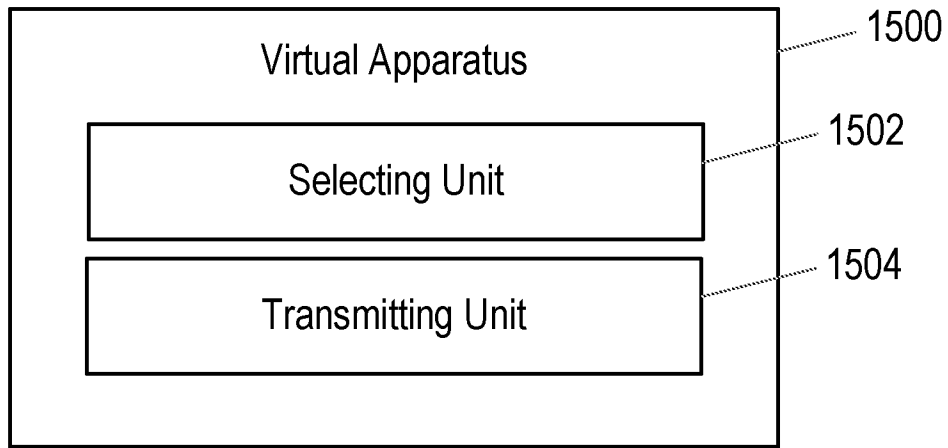

Fig. 15

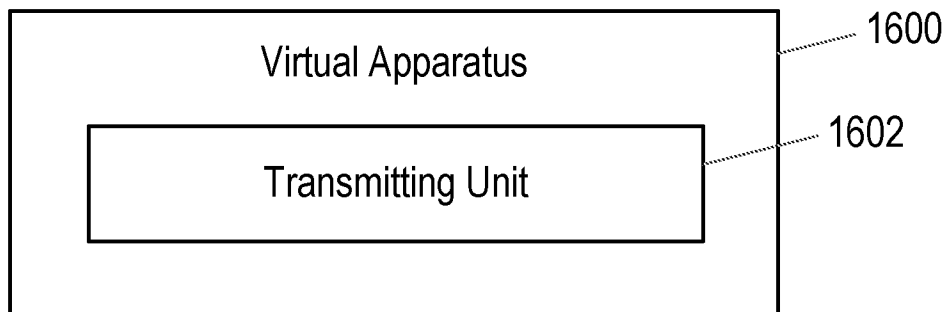

Fig. 16

INTERNATIONAL SEARCH REPORT

International application No
PCT/SE2020/050116

A. CLASSIFICATION OF SUBJECT MATTER
 INV. H04W74/08
 ADD. H04W72/04 H04W68/02

According to International Patent Classification (IPC) or to both national classification and IPC

B. FIELDS SEARCHED

Minimum documentation searched (classification system followed by classification symbols)
 H04W H04L

Documentation searched other than minimum documentation to the extent that such documents are included in the fields searched

Electronic data base consulted during the international search (name of data base and, where practicable, search terms used)
 EPO-Internal, WPI Data

C. DOCUMENTS CONSIDERED TO BE RELEVANT

Category*	Citation of document, with indication, where appropriate, of the relevant passages	Relevant to claim No.
X	US 2018/176847 A1 (FASIL ABDUL LATHEEF [IN] ET AL) 21 June 2018 (2018-06-21) paragraph [0169] - paragraph [0174] paragraph [0175] - paragraph [0177] paragraph [0178] - paragraph [0181] paragraph [0182] - paragraph [0188] paragraph [0189] - paragraph [0212] figures 10, 11	1-26
X	----- US 2016/150573 A1 (PANI DIANA [CA] ET AL) 26 May 2016 (2016-05-26) paragraph [0066] - paragraph [0072]; figure 2 paragraph [0074] - paragraph [0080]; figure 3 paragraph [0083] - paragraph [0085] paragraph [0092] - paragraph [0102] -----	1-26

Further documents are listed in the continuation of Box C.

See patent family annex.

* Special categories of cited documents :

- "A" document defining the general state of the art which is not considered to be of particular relevance
- "E" earlier application or patent but published on or after the international filing date
- "L" document which may throw doubts on priority claim(s) or which is cited to establish the publication date of another citation or other special reason (as specified)
- "O" document referring to an oral disclosure, use, exhibition or other means
- "P" document published prior to the international filing date but later than the priority date claimed

- "T" later document published after the international filing date or priority date and not in conflict with the application but cited to understand the principle or theory underlying the invention
- "X" document of particular relevance; the claimed invention cannot be considered novel or cannot be considered to involve an inventive step when the document is taken alone
- "Y" document of particular relevance; the claimed invention cannot be considered to involve an inventive step when the document is combined with one or more other such documents, such combination being obvious to a person skilled in the art
- "&" document member of the same patent family

Date of the actual completion of the international search
 6 May 2020

Date of mailing of the international search report
 13/05/2020

Name and mailing address of the ISA/
 European Patent Office, P.B. 5818 Patentlaan 2
 NL - 2280 HV Rijswijk
 Tel. (+31-70) 340-2040,
 Fax: (+31-70) 340-3016

Authorized officer
 Puiulet, Alexandru

INTERNATIONAL SEARCH REPORT

Information on patent family members

International application No

PCT/SE2020/050116

Patent document cited in search report	Publication date	Patent family member(s)	Publication date	
US 2018176847	A1	21-06-2018	US 2018176847 A1	21-06-2018
			US 2019342813 A1	07-11-2019
			WO 2016190711 A1	01-12-2016

US 2016150573	A1	26-05-2016	CN 102771174 A	07-11-2012
			CN 106028270 A	12-10-2016
			EP 2534915 A2	19-12-2012
			JP 5611372 B2	22-10-2014
			JP 2013520103 A	30-05-2013
			JP 2014209777 A	06-11-2014
			JP 2016201851 A	01-12-2016
			KR 20130009959 A	24-01-2013
			MY 164719 A	30-01-2018
			TW 201204148 A	16-01-2012
			TW 201705801 A	01-02-2017
			US 2011274040 A1	10-11-2011
			US 2016150573 A1	26-05-2016
			WO 2011100596 A2	18-08-2011
