

Jan. 8, 1935.

B. A. CASPER

1,987,141

WINDING DEVICE

Filed Oct. 6, 1930

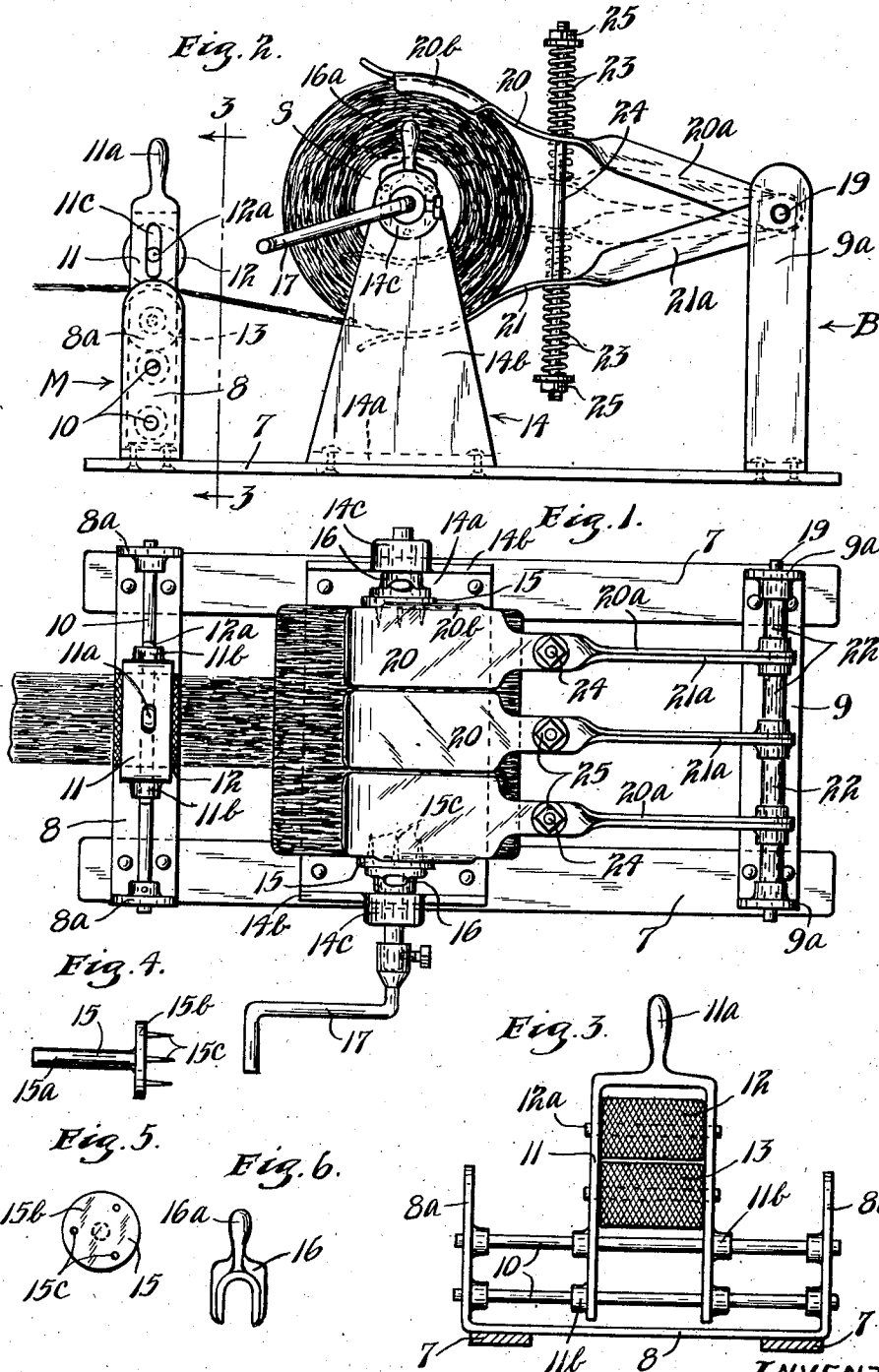

INVENTOR.
BENJAMIN A. CASPER.
BY HIS ATTORNEYS.

Williamson & Williamson

UNITED STATES PATENT OFFICE

1,987,141

WINDING DEVICE

Benjamin A. Casper, Minneapolis, Minn.

Application October 6, 1930, Serial No. 486,524

2 Claims. (Cl. 242—139)

This invention relates to winding devices or machines, capable of wide general use and especially adapted for winding and compacting material comprising a series or multiplicity of individual strands, such as, for example, steel wool.

My improved device is especially well suited for winding and compacting surface treating elements, of the type disclosed in my copending application for Buffing and abrasive device, filed on July 7th, 1930, S. N. 465,916, now Patent Number 1,879,083 of Sept. 27, 1932, wherein it is desirable to produce a rotary and cylindrical abrasive element having spirally wound thereon steel wool filaments, the filaments extending substantially circumferentially of the spool.

It is an object of my present invention to provide a simple but highly efficient device for winding continuous multi-strand ribbons of material, such as steel wool, and for compacting and tensioning the strands substantially uniformly and properly as they are wound upon the spool.

A further object is to provide a winding machine of the type described wherein provision is made for preventing slippage of the strands, filaments or other material at the ends of the roll and wherein simple means are provided for guiding the multi-strand ribbon of material onto the roll.

Another object is to provide a device of the class described wherein the rolls may be quickly and efficiently formed and wherein the finished rolls may be easily and quickly removed from the machine and a new spool substituted.

These and other objects and advantages of the invention will be fully set forth in the following description made in connection with the accompanying drawing, in which like reference characters refer to similar parts throughout the several views, and in which:—

Fig. 1 is a plan view of an embodiment of my invention;

Fig. 2 is a side elevation of the same;

Fig. 3 is a cross section taken on the line 3—3 of Fig. 2 showing the guiding carriage at one end of the machine;

Fig. 4 is a side elevation of one of the spool-engaging elements;

Fig. 5 is a plan view of the same, and

Fig. 6 is a side elevation of a simple spacer and fastening element for operatively securing a spool in the machine.

In the form of the invention illustrated, a suitable base is provided which may comprise spaced longitudinal bars 7 connected together in spaced relation at their terminal portions by means of

transverse bars 8 and 9 respectively, said bars having up-turned vertical opposed ends in each instance constituting mounting brackets. The mounting bracket indicated as an entirety by the letter M at the left hand or forward end of the machine is shorter than the mounting bracket B at the rear of the machine and has secured across the vertical arms 8a a pair of spaced horizontal rods 10 on which a guiding carriage 11 is slidably mounted for movement transversely of the base of the machine. The guiding carriage disclosed, comprises a depending U-shaped frame 11 having a central handle 11a at the upper end thereof and having two pairs of axially aligned slide bearings 11b in the lower portions of the arms of the U. Carriage 11 has journaled therein a pair of vertically aligned rollers 12 and 13 respectively, at least one of which is preferably knurled. The upper roller 12 is provided with trunnions 12a which work in vertical slots 11c formed in the upper portions of the arms of the carriage 11 to permit upward displacement of the roller for compensating for the thickness of the material to be wound.

Across the medial portion of the frame of the machine is secured a standard 14 having a base 14a and a pair of vertical arms 14b constituting brackets for the mounting of a winding spool. Arms 14b carry at their upper ends suitable aligned bearings 14c. The winding spool S which may comprise merely a cylinder of suitable material, such as wood, is preferably rotatably mounted in the arms of standard 14 in the following manner:—

A pair of spool-engaging members 15 are provided, each comprising a stem or shaft 15a of proper diameter to be journaled in one of the bearings 14c, said stem carrying at the inner end thereof disk 15b which has inwardly projecting and circumferentially arranged prongs adapted to be stuck into one end of the spool with stem 15a disposed axially thereof. The two bearings 14c are spaced a sufficient distance apart to enable the spool-engaging elements to be retracted or released from the ends of the spool for removing the spool from my device. A pair of removable spacer elements 16 are provided, each disposed between one of the bearings 14c and one of the disks 15b of the adjacent spool-engaging element. Spacer elements 16 as illustrated in Fig. 6 may comprise a U-shaped member adapted to slide over a portion of the stem of the spool-engaging element and an up-standing handle 16a by which the spacers may be readily removed upwardly. A crank 17 may

be fixed to the outer end of one of the stems 15a for rotating spool S, or obviously suitable means such as a pulley, sprocket or gear may be provided for connection with a source of

5 power.

Mounting bracket B at the rear or right hand end of the machine is provided with opposed vertical arms 9a which have secured across the upper ends thereof a horizontal shaft or pivot

10 rod 19. Several series of upper and lower compacting and tensioning plates 20 and 21 are swingably mounted on shaft 19 and as shown, members 20 and 21 comprise arcuate plates having upturned outer ends and having diminished and

15 twisted shank portions 20a and 21a respectively which are disposed in vertical planes, the ends of said shank portions carrying, if desired, hubs which surround pivot shaft 19. Each pair or series comprises an upper and a lower arm 20

20 and 21 respectively and are spaced from the other series and from the vertical arms of bracket B by suitable means, such as spacing sleeves 22, which surround shaft 19.

It will be noted that the upper compacting and

25 tensioning plate 20 is provided at its longitudinal sides with depending flanges 20b which are adapted to over-lie and guard the edges of the material wound upon spool S, also preventing the filaments or strands during the winding from

30 slipping over the ends of the spool.

The two compacting plates 20 and 21 of each pair are urged inwardly against the spool and material wound thereon and are also urged together by suitable means, such as the coiled

35 springs 23 which surround the outer portions of a rod 24 and which are interposed between the outer surfaces of the respective compacting plates and adjustable collars or washers 25 which are secured to the outer extremities of rod 24.

40 Each of the rods 24 extends substantially vertically and passes through the medial portions of the two plates 20 and 21.

In the embodiment of the invention illustrated, three sets of said compacting and tensioning plates are shown, each plate being in

45 width substantially one-third the length of the spool. It will, of course, be understood that any number of pairs of plates may be utilized, it being the intention to provide a series of plates of such

50 width that tension will be placed by each plate only upon a portion or zone of the material wound or being wound.

Operation

55 The operation of my winding device may be briefly described as follows:

Assuming the material to be wound, is supplied from a relatively large roll, bolt or other source of supply and assuming the material to comprise

60 a continuous ribbon formed from a multiplicity of filaments or strands, the said ribbon is passed between the rollers 12 and 13 of the guiding carriage and thence secured to the winding spool.

Certain of the dotted lines in Fig. 2 indicate

65 the position of the compacting and tensioning plates 20 and 21 at the beginning of the winding operation. It will be apparent that the tension of the coiled springs or other elastic means 23 between the maximum outward and inward positions due to engagement with the spool and the

70 fully wound roll varies only a small amount. Practically a uniform pressure therefore is exerted upon the material wound at the top of the spool and upon the material as it is being wound

75 at the bottom of the spool.

New spools may be quickly inserted into the machine by engaging the prongs of the spool-engaging elements with the spool and slipping the spacers 16 in place between the disks of said spool-engaging elements and the arms of stand-

5 ard 14, thereby holding the spool-engaging elements against outward longitudinal movement.

The material wound from the supply roll is guided smoothly to the winding spool, being maintained by cooperating rollers 12 and 13 in the form of a multi-strand ribbon. By grasping handle

10 11a of the carriage the ribbon may be correctly guided to the spool as the spool is revolved. It will, of course, be apparent that a double worm may be substituted for one of the carriage rods 10

15 and suitable teeth provided in the slide bearings 11b and the worm rotated to automatically slide the carriage back and forth upon the supporting rods.

The plates 20 and 21 urged by the springs 23

20 against the spool and the material wound thereon, produce a braking action upon the ribbon as it is wound, compact the filaments or strands against the spool and material and properly tension the material as it is wound. The depending

25 flanges 20b on the outer longitudinal edges of the end plates 20 prevent the material and/or filaments from slipping outwardly off the spool or material previously wound.

After the spool S has been wound with the material to the desired diameter, the same may be

30 quickly and easily removed from the standard 14 by grasping the handle 16a of the spacing members, slipping the same outwardly and then disengaging the spool-engaging members 15 by out-

35 ward longitudinal movement thereof. The wound spool may then be withdrawn from between the compacting plates 20 and 21.

From the foregoing description it will be seen that I have provided a simple but highly efficient

40 device for winding from a supply roll or bolt, spools of steel wool or other material supplied in the form of a ribbon comprising a multiplicity of strands or filaments. The material will be smoothed and compacted by the guiding carriage

45 and properly fed to the spool for accurate and uniform winding thereon. Efficient means are provided for compacting, braking and tensioning the material as it is wound. It will be noticed that by the particular construction of tensioning

50 means the tension is substantially uniform throughout the winding of the spool within the limits required.

It will, of course, be understood that various changes may be made in the form, details, proportions and arrangement of the parts, without

55 departing from the scope of applicant's invention, which, generally stated, consists in a device capable of carrying out the objects above set forth and in the novel parts and combinations of parts disclosed and defined in the appended claims.

What is claimed is:—

1. In a winding machine, a frame including a spool standard having aligned spaced bearings, a winding spool, a pair of spool engaging members having stems journaled and also slidable in said bearings and having longitudinal projections engageable with the ends of the spool, and a removable spacing member constructed to straddle the

65 shank of one of said stems and insertable between a portion of said spool engaging member and said bearing to produce a wedging action for forcing said spool engaging member inwardly against the end of said spool, and means for turning one

70 of said stems to revolve said spool.

75

2. In a winding machine, a frame including a spool standard having aligned spaced bearings, a winding spool, a pair of spool engaging members having journaled stems and at least one of said stems being slidable in its bearing, at least one of said spool engaging members having longitudinal projections engageable with one of the ends of the spool, and a removable spacing member constructed to straddle the shank of said slidable stem and insertable between a portion of said spool engaging member and said bearing to produce a wedging action for forcing said member inwardly against the end of said spool, and means by which one of said stems may be turned to revolve said spool.

BENJAMIN A. CASPER.