

April 13, 1943.

E. S. DE DE HOFFMAN ET AL

2,316,225

RING-MOUNTED JEWELRY

Filed May 13, 1941

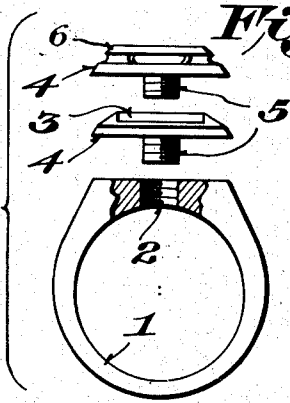

Fig. 1.

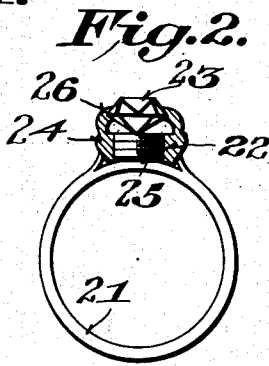

Fig. 2.

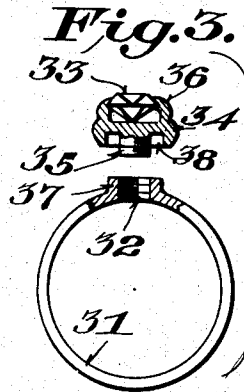

Fig. 3.

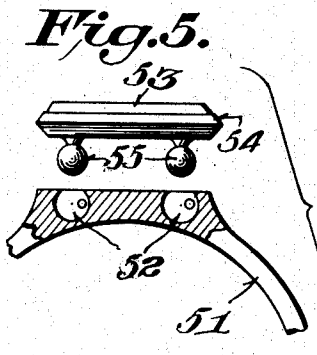

Fig. 5.

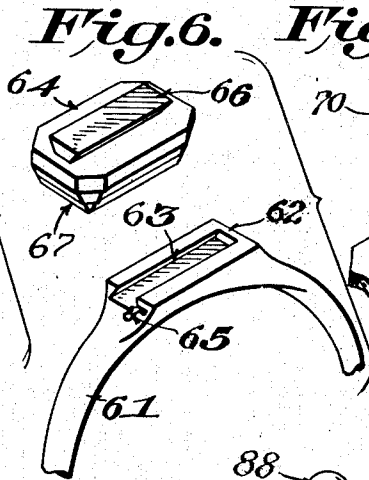

Fig. 6.

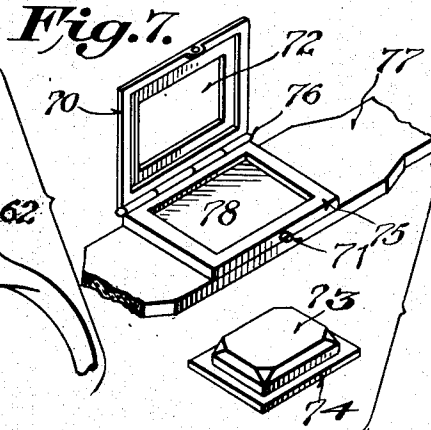

Fig. 7.

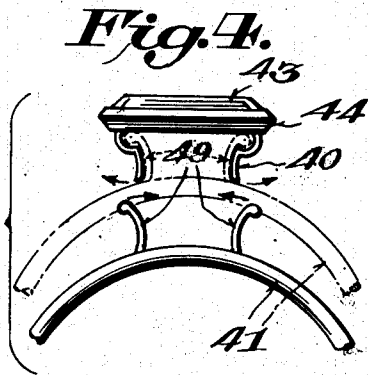

Fig. 4.

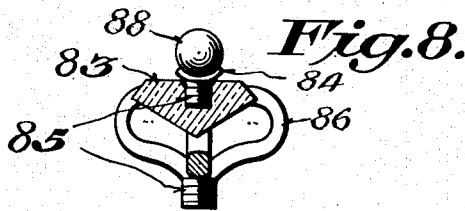

Fig. 8.

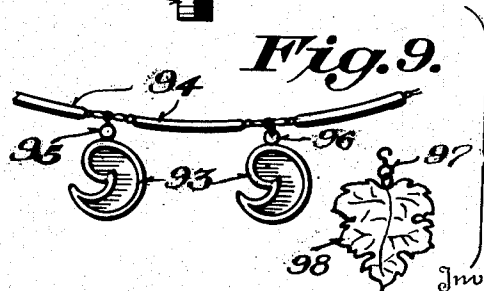

Fig. 9.

Inventors

ELISA STRAJMAN DE DE HOFFMANN,
FELIX DE HOFFMANN,

384 *Walchewitz & Graft*
Attorneys

UNITED STATES PATENT OFFICE

2,316,225

RING-MOUNTED JEWELRY

Elisa Strajman de de Hoffmann and Felix
de Hoffmann, Buenos Aires, Argentina

Application May 13, 1941, Serial No. 393,252
In Argentina April 22, 1941

1 Claim. (Cl. 63—29)

The present invention refers to certain improvements in jewelry, and has essentially for its object, certain improvements in the manufacture of same, which permit of the partial or total replacement or substitution of stones and ornaments, with the object of varying wholly or in part the appearance of said jewelry.

In accordance with the foregoing, the invention consists in providing the stones or ornaments of the jewels, or the supports which hold them, with suitable means, which permit of the temporary and detachable mounting or setting of same on the body of the jewel.

The invention also comprises the provision within the body of the jewel, of suitable means, and corresponding to the means with which the stones or ornaments have been provided, and adapted to permit of the temporary and detachable mounting or setting of these latter upon the former.

Likewise, the invention comprises the provision in stones or ornaments of means which permit a temporary and detachable mounting or setting thereupon of other bodies or stones provided with suitable fixing means.

The jewels to which the invention refers, are any of those employed for personal adornment, such as rings, bracelets, brooches, ear-rings, necklaces, etc., whether of precious metal or any other material.

The means employed for the temporary and detachable setting or assembly of its elements, may be of any appropriate type, some of them being shown in the accompanying drawing, said drawing should be taken as illustrative but in no case as limitative.

To the end that the invention be clearly understood and carried out in practice with complete facility, it has been shown by way of illustration in the accompanying drawing in which:

Figure 1 is a detail of the parts of an embodiment of our invention separate and in juxtaposition, partly in section, in which there is shown one method of carrying out the invention, applied to a ring.

Figures 2, 3, 4, 5 and 6 shew other variations in the carrying out of the method of holding together the component parts of the ring.

Figure 7 shews a variation in the carrying out of the invention, applied to a bracelet or armband.

Figure 8 shows an element of ornament provided with means for the detachable mounting of a second element of ornament, and finally.

Figure 9 shews the form of adaption of the invention to a necklace.

In all the figures mentioned the same reference figures indicate the same corresponding parts.

In the form of construction represented in Figure 1, there has been indicated by the reference number 1, a ring of ordinary type, which is provided with a small orifice 2, suitably threaded, adapted to permit the mounting of the interchangeable stones or ornaments 3. In this case, the said stones 3, may be mounted or fixed by any means on a base 4, of any suitable type, from the lower part of which rises a small threaded stem 5, capable of being screwed in the interior of the orifice 2 of the said ring. As will be understood, by the simple means of unscrewing the stem 5, the base 4 may be detached from said ring, together with the corresponding stone or ornament 3, substituting this latter by a new stone or ornament 6, of a distinct nature, shape, drawing or coloration, by which the appearance of said piece of jewelry will be changed.

The variation represented in Figure 2, is based on the fact that in this case the threaded stem 25 is a solid part of the same ring 21, while the threaded bore 22, for receiving the said stem, is formed in this case in the said base 24, from whose upper part rises an ordinary setting 26, for the mounting of the corresponding stone or ornament 23.

The form of execution represented in Figure 3, which constitutes a slight variation of the disposition illustrated in the former drawings, is characterized by the fact that the bore 32, of the ring, is bordered by a slight circular rim 37, capable of entering into an annular channel or cavity formed in the lower face of the base 34 and situated concentrically with the threaded stem 35, the union between the detachable elements being perfectly hidden.

The variation represented in Figure 4, is based on the fact that the mounting of the stone or ornament, 43, is fitted in this case on the corresponding ring 41, by means of a spring coupling, for which purpose, from the external surface of said ring 41, protrude two or more small spring plates 49, conveniently curved, capable of fitting tightly within other similar elements 40, forming a solid part of the base 44, for the holding or mounting of the corresponding stone or ornament 43, as shown by the dotted lines.

For the mounting of said stone, it will, in this case, be sufficient to press inwards the corresponding plates 49, as indicated by the arrows in said Figure 4, subsequently introducing their ends in the space formed by the fixed plates 40, until

a perfect resilient engagement is obtained between said elements.

The variation represented in Figure 5, is based on the fact that the plate 54, for the support or mounting of the stone, or ornament figure 53, bears, fitted to its lower surface, two or more projections 55, provided with resilient elements, which as shown are advantageously of circular cross-section and capable of fitting inside and fixing themselves by pressure within the interior of small cavities 52, formed in the body of ring 51, or vice versa.

In Figure 6 there is shown another variation of the carrying out of the invention, which is characterized by a slot 63, in the form of a tongue-and-groove, closed at one of its ends by a thin plate 62, and at whose other end is fitted a retainer, composed of a spring or similar catch 65.

In its turn, the plate 64, for the support or mounting of the corresponding stone 67, bears, shaped on its lower surface, a ridge or projection 66, capable of fitting tightly within the inside of the slot 63 of the opposed element 61, in which position it is held perfectly by the spring catch 65.

In Figure 7 there is shown, as has been said, a variation of the carrying out of the invention, applied to a bracelet, armlet or the like.

In this case, there are fixed upon the external surface of the said armlet or the like 77, one or more frames 75, of any suitable shape, which bears on one of its edges, by means of a hinge or similar articulation 76, a second frame 70, capable of being secured in its closed position by means of a latch or the like 71, or any other suitable securing device. In this case, the stone or ornament 73 is of such a shape that it may be made to project through the opening 72 of the movable frame 70, while the base of support 74, in its turn, remains perfectly tight in the internal cavity 78, of the fixed frame 75.

The variation of execution represented in Figure 8, is based on the fact that the stone or ornament 83, which is fitted in the form already described, on the base or mounting 86, bears fitted, in its turn, a second stone or ornament 88 situated on a base or mounting 84 which is detachably fitted on the said element 83 by means of a threaded stem 85 or by any other of the means previously described.

Finally, in Figure 9 there can be seen a piece of a necklace 94, provided with applications of hanging stones or ornaments 93, which are detachably fitted to the said necklace by any suitable means, as for example by means of small hooks 95, permitting the detachment and change of said element, for other elements of ornament 98, of a distinct shape, position or motif, with the object of varying wholly or in part the appearance of said jewel.

It is obvious that the invention may be applied in the same manner as has just been described, to any of the types of jewels already specified, or others for personal adornment, such as charms, armlets, rings, clips, pendants, buckles and the like whether of fine or fancy class.

In its turn, each one of the jewels mentioned may be provided, independently, with means for application to some of distinct types of ornaments, capable of being detached or changed wholly in part, said means being of the same or distinct nature, whether of any of the types specified in the drawing, or of any other type adequate for their purposes. It should also be noted, that on referring in the specification and claim, to stones and ornaments, it is understood that such reference is made to brilliants, pearls, diamonds or any other type of ornaments such as cameos, seals, letters, monograms, or any other article or product whether of fine jewelry or fancy ornaments.

The invention as described is believed to be clearly understandable and does not require further explanation for those skilled in the art.

What we claim is:

In a ring for personal wear, a finger engaging annulus, and a separate gem mounting base, the back of said base being provided with curvilinearly contoured resilient protruding plate members, and said annulus being provided with curvilinearly contoured resilient engaging plates which are respectively contoured substantially parallel to the curvilinear contour of said protruding plate members, and adapted for mutual locking engagement of the parallel adjacent contoured surfaces of said plate members and said plates over substantially their entire extent.

ELISA STRAJAN DE DE HOFFMANN.
FELIX DE HOFFMANN.