

(No Model.)

3 Sheets—Sheet 1.

E. & F. W. HEYMANN. ELECTRIC ARC LAMP.

No. 522,294.

Patented July 3, 1894.

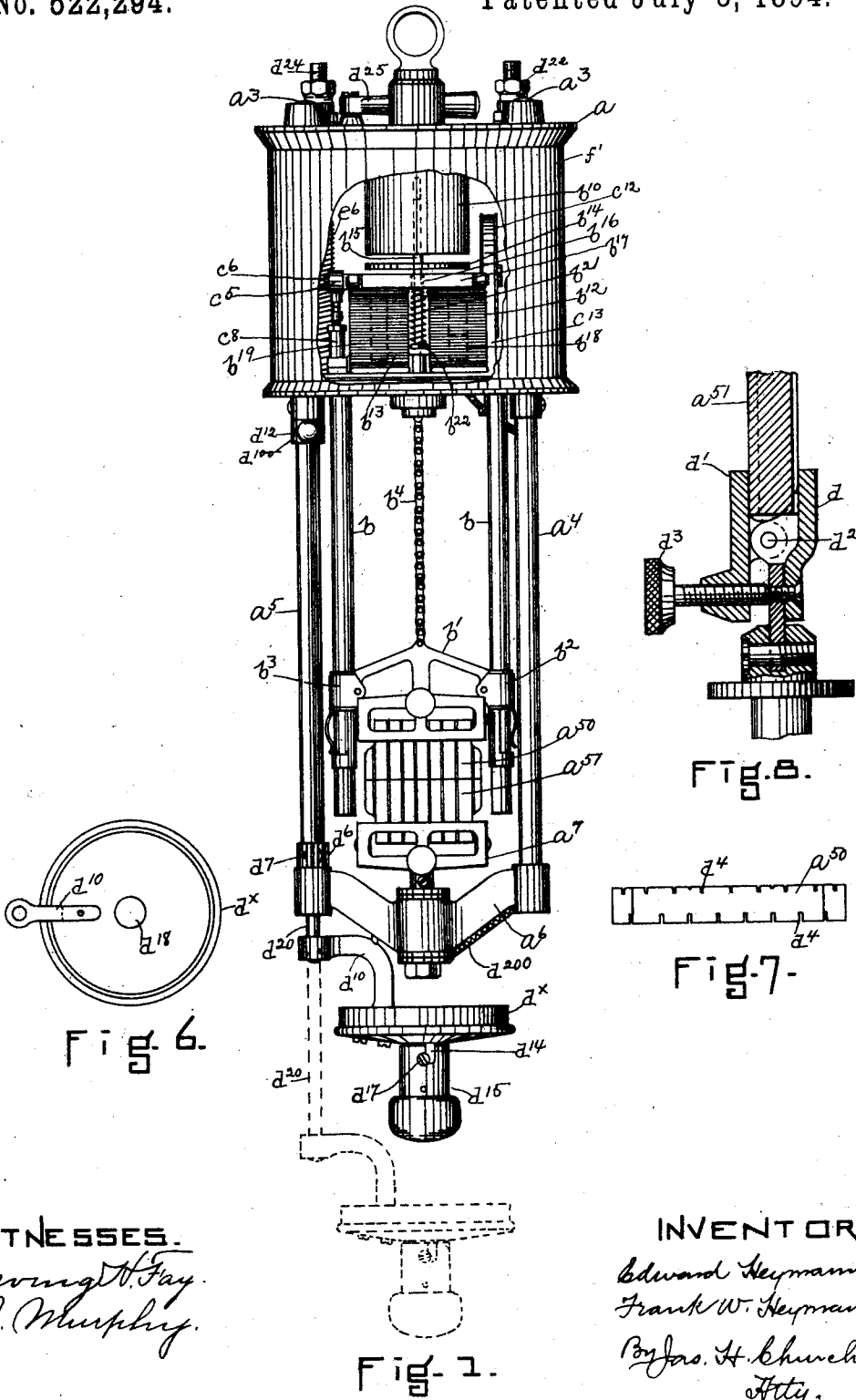

WITNESSES.
Irving H. Fay.
J. Murphy.

INVENTORS
Edward Heymann,
Frank W. Heymann
By Jas. H. Churchill
Atty.

E. & F. W. HEYMANN.
ELECTRIC ARC LAMP.

No. 522,294.

Patented July 3, 1894.

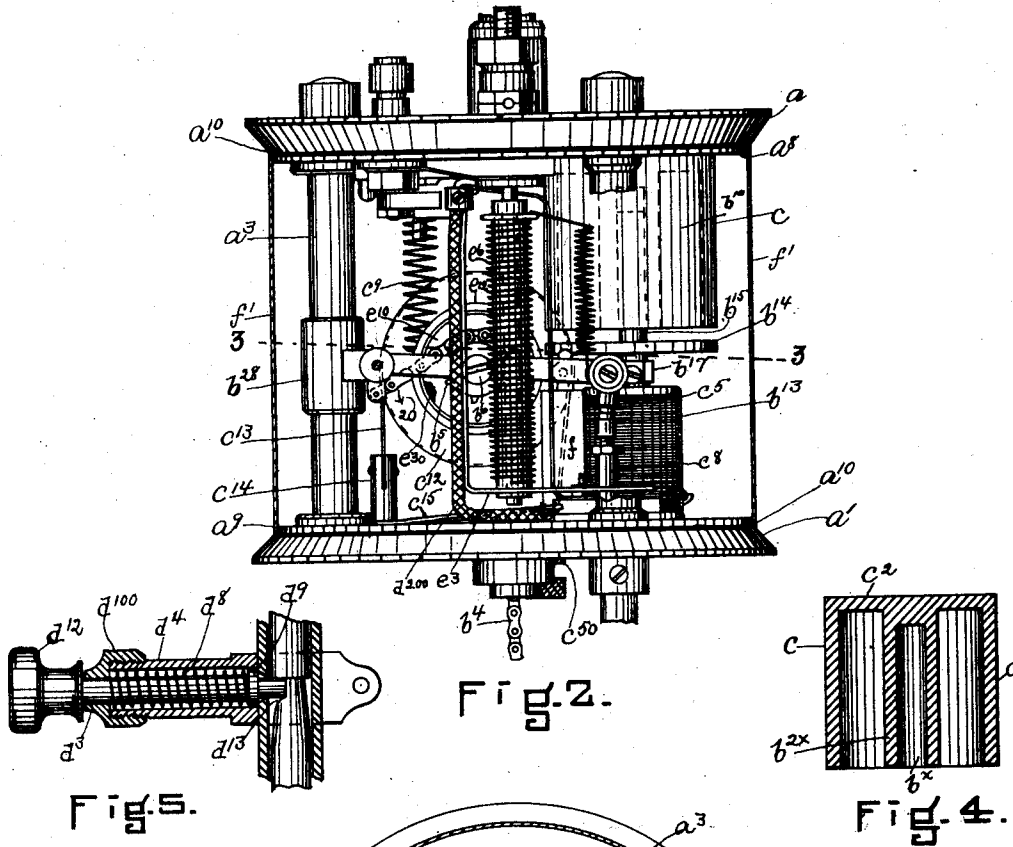

Fig. 2.

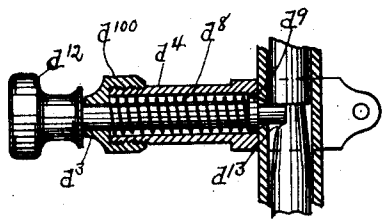

Fig. 5.

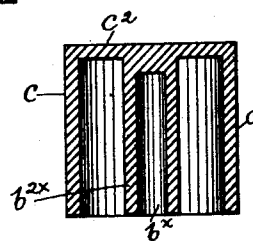

Fig. 4.

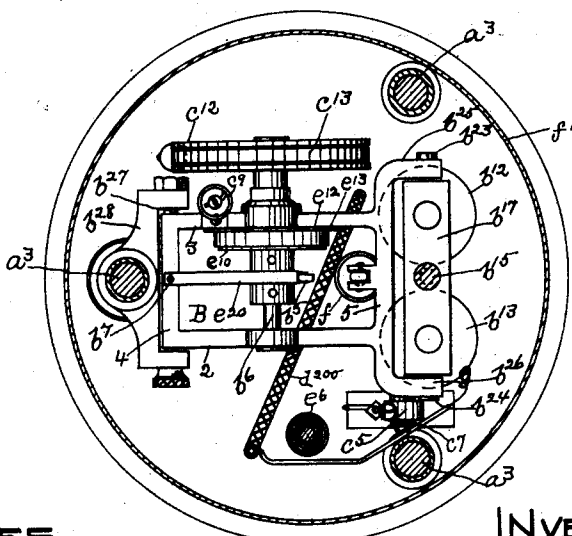

Fig. 3.

WITNESSES.
George H. Gay
J. Murphy

INVENTORS
Edward Heymann
Frank W. Heymann
By Jas. H. Churchill
Atty.

UNITED STATES PATENT OFFICE.

EDWARD HEYMANN AND FRANK W. HEYMANN, OF BOSTON, MASSACHUSETTS.

ELECTRIC-ARC LAMP.

SPECIFICATION forming part of Letters Patent No. 522,294, dated July 3, 1894.

Application filed April 14, 1893. Serial No. 470,308. (No model.)

To all whom it may concern:

Be it known that we, EDWARD HEYMANN and FRANK W. HEYMANN, residing in Boston, in the county of Suffolk and State of Massachusetts, have invented an Improvement in Electric-Arc Lamps, of which the following description, in connection with the accompanying drawings, is a specification, like letters and figures on the drawings representing like parts.

This invention relates to electric arc lamps, and has for its object to improve and simplify the construction of the same.

One feature of our present invention consists in a novel construction and arrangement of the carbon operating magnets, whereby, a more efficient feeding of the carbons may be obtained to thereby produce a steadier and more even light.

Another feature of our invention consists of a novel construction of globe holder, whereby the said holder may be readily lowered from the lamp to permit of the easy replacement of the lower carbon and also of the globe itself, the supporting base for the lamp globe being preferably constructed with a discharge orifice for the carbon dust usually accumulated in the globe holder, the said orifice being normally closed by a removable cap, as will be described.

Our invention further consists in a novel construction of the carbon and its holder, whereby the lamp frame may be materially shortened, the carbon being preferably constructed as will be described to prevent racing of the arc, thereby obtaining a steadier light and effecting a more even consumption of the carbon.

These and other features of our invention will be pointed out in the claims at the end of this specification.

Figure 1, represents in elevation an arc lamp embodying this invention, the globe holder being represented by dotted lines in its lowered position, the cover or casing for the lamp being partially broken out to show the interior construction; Fig. 2, a side elevation on an enlarged scale of the body of the lamp shown in Fig. 1, the cover being shown in section; Fig. 3, a transverse section of the lamp shown in Fig. 2, the section being sup-

posed to be taken on the line 3—3, Fig. 2; Fig. 4, a sectional detail of the shell of the main line or series magnet; Fig. 5, a detail to be referred to; Fig. 6, a top or plan view of the globe holder removed; Fig. 7, a top or plan view of one of the carbons; Fig. 8, a sectional detail to more clearly show the construction of the carbon holder preferred by us, and Fig. 9, a side elevation similar to Fig. 2 but on a larger scale, with some of the parts shown in Fig. 2 omitted.

Referring to Fig. 1, the lamp frame is represented as composed of an upper metal plate or disk a , and a lower metal plate or disk a' , separated from each other by suitable standards or posts a^3 (see Figs. 2 and 9), which are extended through the plates or disks a and a' and have secured to or forming part of them, preferably hollow side rods a^4 a^5 , having secured to them at their lower ends a yoke or cross bar a^6 constituting a support for a lower carbon holder a' of a construction, as will be described.

In order that the lamp frame may be dead or free from current when in use, the metal disks and plates a a' have interposed between them a supporting case or cage for the operating parts of the lamp, the said case or cage preferably consisting of two metal disks or plates a^8 a^9 secured to the disks or plates a a' , but separated therefrom by plates or disks a^{10} of insulating material. The metal disk or plate a^9 , electrically separated from the plate or disk a' , has connected to it in any suitable manner, depending guide rods b for the upper carbon holder b' , of a construction as will be described, the said guide rods being extended through the disk a' and electrically separated therefrom and secured in any suitable manner to the lower disk or plate a^9 of the cage. The upper carbon holder b' is provided with tubular collars b^2 b^3 , which slide upon the guide rods b , the said carbon holder being connected, as herein shown, to one end of a sprocket chain b^4 extended up through the disks or plates a' a^9 and passed about a sprocket wheel b^5 mounted upon a shaft b^6 , having bearings in a supporting frame B herein shown as rectangular in shape (see Fig. 3) and consisting of the side bars 2, 3, and rear and front end bars 4, 5, the sprocket chain b^4 hav-

ing its other end fastened as by a screw b^7 to the rear cross bar 4 of the said frame.

The lamp herein shown, in accordance with our invention, is provided with a novel construction and arrangement of electro-magnets to effect the movement of the upper carbon holder b' and thereby the feed of the lamp.

In accordance with our invention, the lamp is provided with a main line or series electro-magnet b^{10} preferably of a construction as will be described, and solenoids b^{12} b^{13} constituting the shunt magnets for the lamp. The electro-magnet b^{10} has co-operating with it an armature b^{14} preferably made in the form of a disk, which is mounted upon a support preferably a non-magnetic rod b^{15} , extended up into a core or hole b^x (see Fig. 4) in the central pole piece b^{2x} of the magnet b^{10} , the said rod being also extended through a hole or opening b^{16} , indicated by dotted lines in Fig. 1, in the armature b^{17} for the shunt solenoids or magnets b^{12} b^{13} , the said armature being secured to or forming part of the cores b^{18} b^{19} for the said solenoids. The non-magnetic rod b^{15} below the armature b^{17} is encircled by a yielding medium preferably a spring b^{21} , one end of which abuts against the armature b^{17} and the other end against a nut b^{22} adjustable on the threaded end of the rod b^{15} , for a purpose as will be described. The armature b^{17} of the shunt solenoids b^{12} b^{13} is pivotally supported at its ends as by screws b^{23} b^{24} in arms b^{25} b^{26} , secured to or forming part of the front cross bar 5 of the supporting frame B, the rear cross bar 4 of the said frame being pivotally mounted on a shaft b^{27} , having bearings in a yoke or frame b^{28} secured to one of the posts or uprights a^3 . The main line electro-magnet b^{10} is provided with the central metallic core or pole piece b^{2x} and with circumferential pole pieces preferably made in the form of a magnetic shell or ring c , secured to or forming part of a back strap or disk c^2 , to which the central pole piece b^{2x} is also secured or forms a part; or the shell c and pole piece b^{2x} may be made separate and fastened to the back strap c^2 in any suitable manner. The central core b^{2x} is provided with the usual coarse winding, not herein shown, but which may be first wound on a spool, which is driven or slipped onto the core b^{2x} , and by means of which winding, the central core is made of one polarity, as for instance, north, and the shell c is made of the other polarity, as for instance, south, which co-operate with unlike polarities in the disk armature b^{14} , so that, when the disk armature b^{14} is attracted to the pole pieces of the electro-magnet b^{10} , it will be held to its pole pieces by the residual magnetism in the same, and when the armature b^{14} is once attracted by the magnet b^{10} , it remains stationary and is not moved by the variations in the current strength, the regulation of the arc being effected by the shunt magnets b^{12} b^{13} and the spring b^{21} , thereby rendering the movement of the upper carbon more sensitive to slight variations in the current strength,

and as a result obtaining an almost constant arc and thereby a steadier light.

When the main line electro-magnet is energized, the attraction of the armature b^{14} carries the non-magnetic rod b^{15} up into the hollow core or pole piece b^{2x} , and by means of the spring b^{21} lifts the armature b^{17} for the shunt magnets or solenoids b^{12} b^{13} , and opens the main line shunt circuit as will be described, the armature carrying frame B having secured to it one terminal of the shunt circuit, which terminal is herein shown as a metallic collar c^5 (see Fig. 1) mounted upon a projection c^6 extended from one arm as b^{26} of the armature supporting frame B, the terminal c^5 being electrically separated from the projection c^6 by insulating material c^7 . The terminal c^5 co-operates with a similar terminal herein represented as a stud or post c^8 erected upon the base plate a^9 of the cage. The armature supporting frame B is counterbalanced or held in equilibrium by means of a spring c^9 (see Figs. 2 and 9) having one end secured to the said frame and its other end secured to the plate or disk a^8 . The shaft b^6 upon which is mounted the sprocket wheel b^5 has also fast on it a disk or pulley c^{12} , having passed about it a band or strap c^{13} preferably of metal, one end of which is made fast, as herein shown, to the upright c^{14} erected from the plate a^9 , and the other end of which is secured to a flat spring c^{15} , having its other end fastened to the plate a^9 in any suitable manner, it being herein represented as fastened to the plate a^9 by the upright a^{14} (see Figs. 2 and 9), the disk or wheel c^{12} and its co-operating band c^{13} and spring c^{15} , constituting one form of friction brake-mechanism by which the upper carbon holder b' is held in its elevated position into which it is raised by the energizing of the main line magnet. The spring c^{15} is preferably adjustable at its free end by means of a set screw c^{50} extended up through the plates or disks a' a^9 , and upon which rests the free end of the flat spring c^{15} when the frame B is in its lowered or inoperative position.

By means of the adjusting screw c^{50} and the spring c^{15} , the frame B is caused to move a greater or less distance before engaging the friction wheel with the band c^{13} to make the shaft b^6 fast to the frame B, and as the upward movement of the upper carbon is effected by the sprocket chain, the sooner the sprocket wheel is made fast to the frame B in the upward movement of the said frame, the sooner the carbon is lifted, and consequently the size of the arc is predetermined by the position of the friction band with relation to the friction disk c^{12} . This predetermined position is obtained by the adjusting screw c^{50} , for when the screw c^{50} is withdrawn from engagement with the flat spring c^{15} , the free end of the latter drops down toward the disk a^9 , carrying with it the band c^{13} and bringing the latter into engagement with the disk or pulley c^{12} , so that, if the frame B is moved up-

ward with the band in the position just described, the upper carbon will be lifted the full extent of the upward movement of the frame B, and a large arc will be established between the carbons. If the adjusting screw c^{50} is turned so as to lift the free end of the flat spring c^{15} , the band c^{13} is lifted from the friction disk c^{12} , and consequently the rocking frame B, when lifted, moves a certain distance before the disk c^{12} is engaged with the band c^{13} , and during this movement of the frame B, the upper carbon is not lifted, but on the continued movement of the said frame after engagement of the disk c^{12} with the band c^{13} , the upper carbon is lifted to establish the arc, by reason of the shaft b^6 carrying the sprocket wheel and friction disk c^{12} , being held from revolving by the band c^{13} and spring c^{15} , the free end of the latter being lifted on the continued movement of the frame B.

By adjusting the screw c^{50} so as to raise the free end of the spring c^{15} more or less, the frame B will be moved a greater or less portion of its full upward movement before the upper carbon is acted upon or lifted, and therefore the size of the arc established between the carbons, when the lamp is placed in circuit, may be determined upon by adjusting the screw c^{15} as described.

The carbon holders $a^7 b'$ are constructed, as herein shown, to receive and hold substantially wide and flat pieces of carbon $a^{50} a^{51}$, the said holders being each provided with a fixed jaw d (see Fig. 8) and a movable jaw d' pivoted to the fixed jaw, as at d^2 , and adapted to be turned on its pivot by a screw d^3 , by which the carbon holder may be made smaller or larger to engage carbon blocks, slabs or pieces of greater or less thickness. In order to obtain a most efficient working lamp, the carbon blocks, in the present instance shown as substantially rectangular in shape, are provided with continuous contacting surfaces and preferably provided with cuts, serrations or channels d^4 made in its opposite surfaces or faces in the direction of the flow of the current, and, for the best results, the serrations or channels d^4 on opposite faces are alternately arranged as represented in Fig. 7.

In arc lamps provided with carbons made of substantially wide surfaces or blocks without the serrations, grooves or channels, the arc between the carbon blocks usually becomes much longer at one point or end of the carbon blocks, owing to soft spots or imperfections in the carbons. In such cases, the arc races, (as it is technically termed) from one end or point of highest resistance to the end or point of lowest resistance, and as a result the carbons are burned off irregularly and leave a ragged edge, which causes the arc to fluctuate from one point to another, thereby giving an unsteady light. By means of the serrations, grooves or channels, the flow or racing of the current from one end or point of the carbons to the other, is diminished and practically prevented by reason of the resist-

ance to the flow, caused by reducing the area or thickness of the edge of each carbon, as represented in Fig. 7, and the best results are obtained by the alternate arrangement of the grooves, serrations or channels. This result is also effected when the carbon blocks are made of other forms, such as disks, and provided with the surface serrations, grooves or channels, and we do not desire to limit our invention to any particular form of carbon block or slab.

The lamp is provided with a globe holder represented as a substantially cylindrical disk or cup-shaped base or frame d^x having secured to it a bracket d^{10} , which, in turn, is secured to the lower end of a rod d^{20} , normally extended up through one of the hollow side rods $a^4 a^5$, it being herein represented as extended up through the rod a^5 . The rod d^{20} is movable in the side rod a^5 and may be normally held up within the rod a^5 , by a suitable catch or locking device, which may be made as represented in Fig. 5, it consisting of a rod d^3 extended through a hollow boss or tube d^4 , which is clamped or otherwise secured to the side rod a^5 , it being herein represented as provided with a split collar or ring d^6 adapted to be secured by a set screw d^7 . The rod d^3 within the tube d^4 is encircled by a spring d^8 , one end of which bears against a collar d^9 mounted on the said rod, and the other end of which bears against a movable cap d^{100} , secured or otherwise fixed upon the tube d^4 and through which the rod d^3 extends, the said rod being provided with a suitable head or handle d^{12} . The side tube or rod a^5 is provided with an opening through which the inner end of the rod d^3 extends, and the rod attached to the globe support d^x is provided with a socket or notch d^{13} (see Fig. 5) into which the end of the rod d^3 is adapted to be forced by the spring d^8 , when the rod d^{20} has been inserted up in the side tube a^5 into its normal position. The side rod a^5 at its lower end has secured to it a second tube provided with a catch pin or rod d^9 , which is adapted to engage with the notch or socket in the rod d^{20} , when the globe holder d^x has been lowered into its dotted line position, and if it is desired to remove the globe holder entirely from the lamp, the second pin d^9 may be withdrawn from engagement with the notch d^{13} in the tube holder, and the rod d^{20} may be removed from the side rod a^5 .

The globe supporting disk or cup-shaped frame or base d^x is provided, as herein shown, with a tubular extension d^{14} normally closed by a removable cap d^{15} , the said cap, as herein represented, being provided with a rectangular slot adapted to co-operate with a pin or projection d^{17} on the said tubular extension, the latter being made hollow to form a discharge orifice d^{18} for the carbon dust, which may accumulate in the globe holder d^x , the cap d^{15} being readily removable from the tubular extension d^{14} to permit the carbon dust to be brushed through the discharge tubular ex-

tension d^{14} . The lower carbon holder is electrically connected to the negative binding post of the lamp body, as herein shown, by an insulated conductor d^{200} extended up through the hollow guide rod a^4 and up through the base plates a' a^9 . The lamp may be provided with a manually operated switch represented in Fig. 9, one terminal d^{21} of the switch being connected to the positive binding post d^{22} , and the other or movable terminal d^{23} being connected to the negative binding post d^{24} , the movable terminal d^{23} being represented in Fig. 1, as provided with a handle d^{25} .

In practice, the main line magnet b^{10} and the shunt magnets b^{12} b^{13} are connected in circuit in the usual and well-known manner, the coil of the main line magnet b^{10} having one end connected to the positive binding post d^{22} , and the other end of its coil connected to the positive carbon a^{50} , the lower carbon a^{51} being connected by wire d^{200} to the negative binding post d^{24} . The circuit just described is followed by the current when the lamp is working under normal conditions. The shunt coils or magnets b^{12} b^{13} are connected directly to the positive and negative binding posts respectively. The lamp is also provided with a shunt circuit for the main line, which includes the terminals c^5 c^8 , the terminal c^8 being connected to the positive binding post d^{22} and the terminal c^5 being connected through the resistance coil e^6 to the negative binding post d^{24} .

In practice, the lamp is cut into circuit by turning the handle d^{25} so as to remove the terminal d^{23} from contact with the terminal d^{21} , the current flowing through the main line magnet b^{10} thereby energizing the said magnet, which attracts its armature b^{14} , and by means of the rod b^{15} and spring b^{21} rocks or moves the frame B upward, the upward movement of the frame B lifting the sprocket chain and the upper carbon a predetermined distance according to the adjustment of the screw e^{50} , and thereby establishing the arc between the carbons, and at the same time lifting the terminal c^5 from the terminal c^8 and opening the main line shunt or cut out circuit. The current continues to flow through the main line magnet while the conditions of the lamp circuit remain normal, but as soon as the carbons have been consumed to interpose abnormal resistance in the main line circuit, a portion of the current is diverted through the shunt magnets, thereby energizing the said magnets which attract their cores b^{18} b^{19} and draw the armature b^{17} downward against the resistance of the spring b^{21} on the rod b^{15} , which latter is held stationary by the lagging of the armature b^{14} . The armature b^{17} on its downward movement carries with it, the frame B, thereby removing the friction disk c^{12} from engagement with its band c^{13} , permitting the upper carbon to descend by gravity a sufficient distance to reduce the size of the arc to its normal. It will thus be seen

that while the lamp is working, the armature of the series or main line magnet is not moved by the variations in the current strength, and that the downward and upward movements of the upper carbon are effected by the shunt magnets b^{12} b^{13} and the spring b^{21} respectively, by which a very sensitive feeding lamp is obtained.

When the upper carbon holder is lifted by hand, as for the purpose of trimming the lamp, the slack in the sprocket chain is taken up, preferably by a coiled or normally wound up spring e^{30} , located within a drum e^{10} fast on the shaft b^6 , one end of the said spring being made fast to the shaft b^6 and its other end to a flanged disk e^{12} fast to the frame B and within the annular flange e^{13} of which the drum e^{10} is adapted to revolve. As soon as the chain b^4 becomes slack, the spring referred to, unwinds and rotates the shaft b^6 and its sprocket wheel in the direction indicated by arrow 20, Figs. 2 and 9, to take up the slack in the said chain. The sprocket chain b^4 is preferably held in engagement with its sprocket wheel by a light flat spring e^{20} fastened by the screw b^7 to the rear bar 4 of the frame B. The coiled spring e^{30} enables the slack in the chain to be taken up within the body or cage of the lamp, thereby enabling the body of the lamp to be made substantially small and compact.

The frame B may be steadied in its movement toward the shunt magnets by a dash-pot f of any usual or well-known construction, by means of which the said frame is prevented from being rapidly moved by sudden variations in the current.

The parts of the lamp between the disks a may be protected from the weather by a cylindrical shell or casing f' made in two parts, which are fastened together in any suitable manner.

We claim—

1. In an electric arc lamp, the combination of the following instrumentalities, viz:—a main line electro-magnet, an armature therefor, a shunt magnet located substantially in line with the main line magnet, an armature for said shunt magnet interposed between the said magnets, a support for the armature of the main line magnet extended beyond the armature of the shunt magnet, and a yielding or elastic medium carried by the support for the main line armature and acting upon the armature of the shunt magnet to move the armature of the shunt magnet in the same direction as the armature of the main line magnet when the said main line magnet is energized, substantially as described.

2. In an electric arc lamp, the combination of the following instrumentalities, viz:—a main line electro-magnet provided with an armature and constructed to present both poles of the magnet to the said armature, a support to which said armature is secured, a shunt magnet, an armature for said shunt magnet, a frame connected to the shunt armature to

move therewith, a sprocket wheel carried by said frame, a carbon holder, a sprocket chain secured to said carbon holder and engaging said sprocket wheel, and a yielding support for said shunt armature secured to the support for the main line armature, substantially as described.

3. In an electric arc lamp, the combination of the following instrumentalities, viz:— a main line electro-magnet, an armature therefor, a shunt magnet, an armature for said shunt magnet, a support for the armature of the main line magnet, and an elastic or yielding medium for said support and acting upon the armature of the shunt magnet, when the main line magnet is energized, in the same direction as the armature of the main line magnet is moved, substantially as described.

4. In an electric arc lamp, the combination of the following instrumentalities, viz:— a main line electro-magnet provided with an inner core or pole piece and with one or more outer or circumferential pole pieces, an armature co-operating with said pole pieces, a shunt magnet provided with an armature, a support to which the armature of the main line magnet is secured, a spring carried by the said support and acting on the shunt magnet armature, substantially as described.

5. In an electric arc lamp, the combination of the following instrumentalities, viz:— a lamp frame provided with side rods, one of which is hollow, a lower carbon holder secured to said side rods, a globe holder provided with a single rod adapted to enter the hollow side rod and movable independent of the lower carbon holder, and spring actuated locking devices located at the upper and lower ends of the hollow side rod to engage the said globe holder rod, the said rod being capable of being entirely withdrawn from the hollow side rod, substantially as described.

6. In an electric arc lamp, the combination of the following instrumentalities, viz:— a lamp frame provided with stationary side rods, a lower carbon holder secured to the said stationary side rods, guide rods depending from the lamp frame within the side rods and disconnected from or independent of the lower carbon holder, and an upper carbon holder movable on said guide rods, substantially as described.

7. The herein described carbon for arc lamps, it consisting of a block provided with grooves, channels or serrations alternately arranged on its opposite faces, substantially as described.

8. In an electric arc lamp, the combination of the following instrumentalities, viz:— a main line electro-magnet, a shunt electro-magnet, a rocking frame, a shaft loosely mounted in said frame, a sprocket wheel on said shaft, a sprocket chain passed over the said sprocket wheel and having one end secured to the upper carbon holder and fastened at its other end, a disk or pulley on said shaft, a friction band co-operating with said disk or pulley, and means to rotate said friction wheel to take up the slack in the sprocket chain when the upper carbon is raised to trim the lamp, substantially as described.

9. In an electric arc lamp, the combination with a main line electro-magnet, of a frame movable by said magnet when energized, a shaft carried by said frame, a flexible carbon holder connected to the said shaft to be moved thereby, a friction surface or disk on said shaft, a band to engage with said disk, but normally disengaged therefrom and means to adjust the position of said band with relation to its disk to thereby govern the extent of movement of the said frame before the friction disk is engaged with the said band to vary the size of the arc, substantially as described.

10. In an electric arc lamp, the combination with a main line electro-magnet, of a frame movable by said magnet when energized, a shaft carried by said frame, a carbon holder connected to the said shaft to be moved thereby, a friction surface or disk on said shaft, a band to engage said disk, a flat spring having one end secured to the free end of the spring, substantially as described.

In testimony whereof we have signed our names to this specification in the presence of two subscribing witnesses.

EDWARD HEYMANN.
FRANK W. HEYMANN.

Witnesses:

JAS. H. CHURCHILL,
J. MURPHY.