

[54] **INSECTICIDAL JET FOGGER**

[72] Inventors: **Robert Schmedes, Rochester; John M. Nelson, Webster, both of N.Y.**

[73] Assignee: **Bernzomatic Corporation**

[22] Filed: **Sept. 15, 1969**

[21] Appl. No.: **857,984**

[52] U.S. Cl. ....43/129, 252/359 A

[51] Int. Cl. ....A01m 7/00

[58] Field of Search ....43/129, 125; 252/359.1

[56] **References Cited**

**UNITED STATES PATENTS**

2,615,215 10/1952 Stagner .....43/129 X

3,229,409 1/1966 Johnson .....43/129

**FOREIGN PATENTS OR APPLICATIONS**

652,970 11/1962 Canada .....43/129

*Primary Examiner*—Warner H. Camp  
*Attorney*—Burgess, Dinklage & Sprung

[57] **ABSTRACT**

A hand held and operated jet fogging device comprises a carrier or housing holding a tank for the insecticidal oil and a L. P. gas cartridge. The housing has on its upper portion a carrying handle aligned with the axis of the housing. A cylindrical guard extends from the housing in alignment with the axis of the housing and contains a burner, vaporizing coil and jet nozzle.

**3 Claims, 4 Drawing Figures**

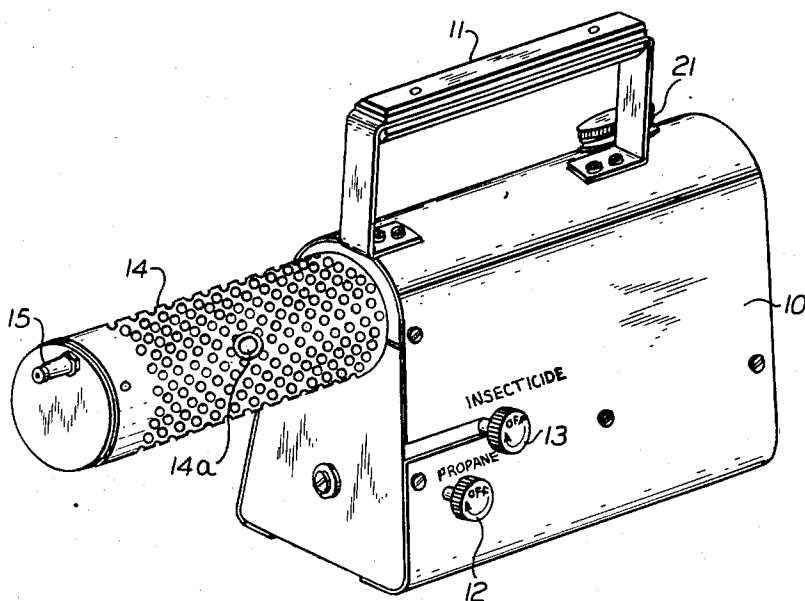

FIG. 1.

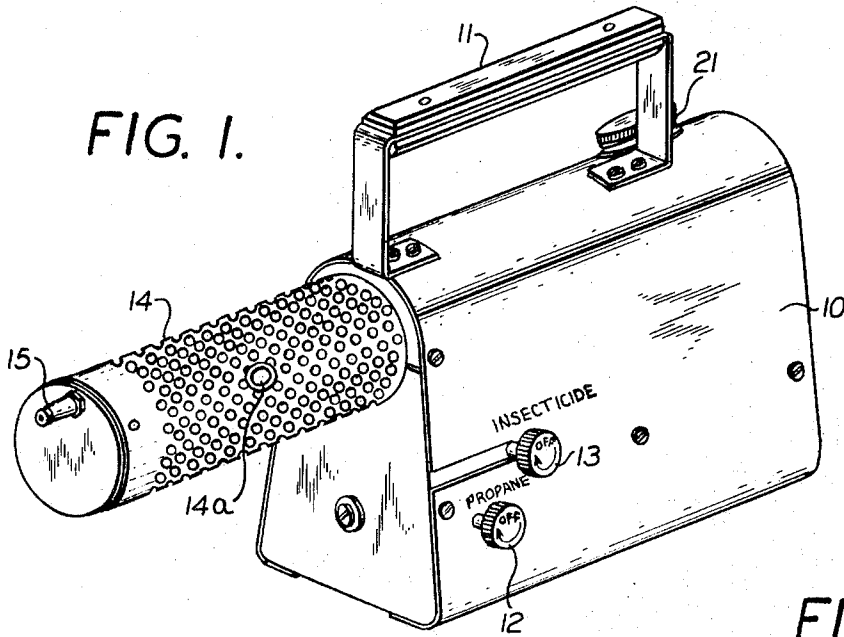
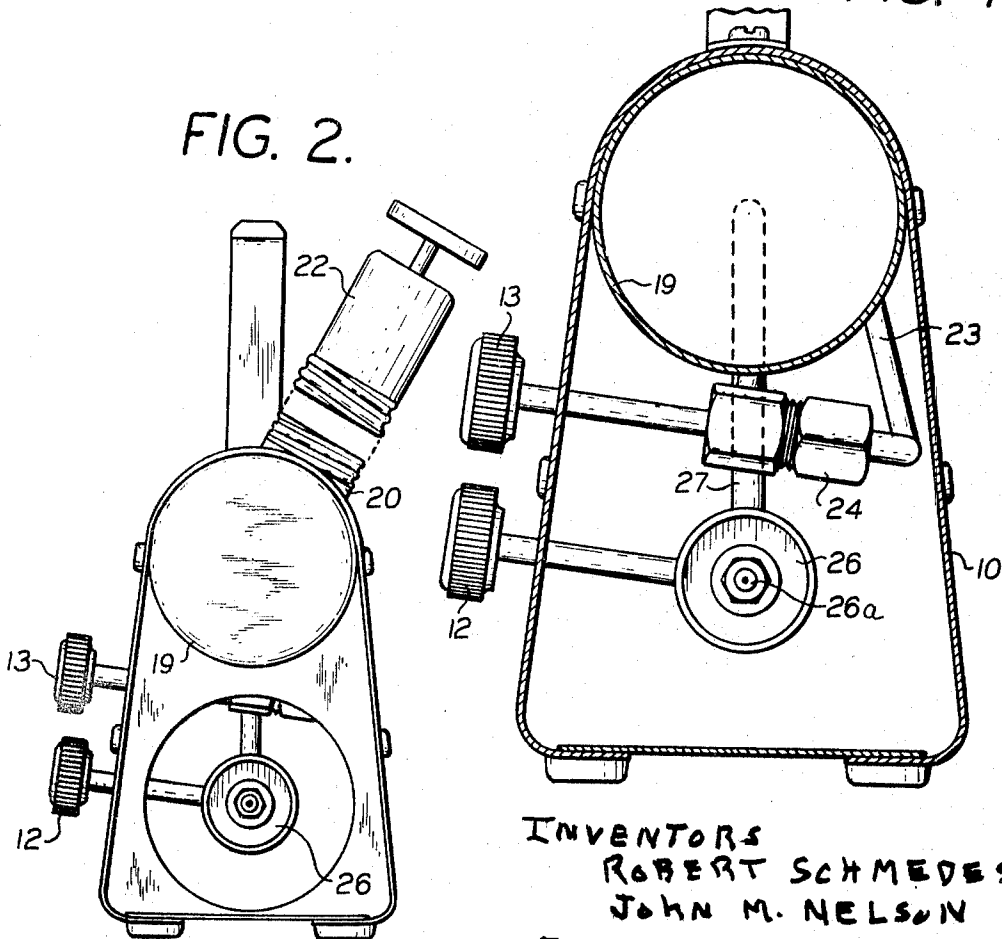

FIG. 4.

FIG. 2.



INVENTORS  
ROBERT SCHMEDES  
JOHN M. NELSON

BY  
BURGESS, DIMKLAGE & SPRUNG

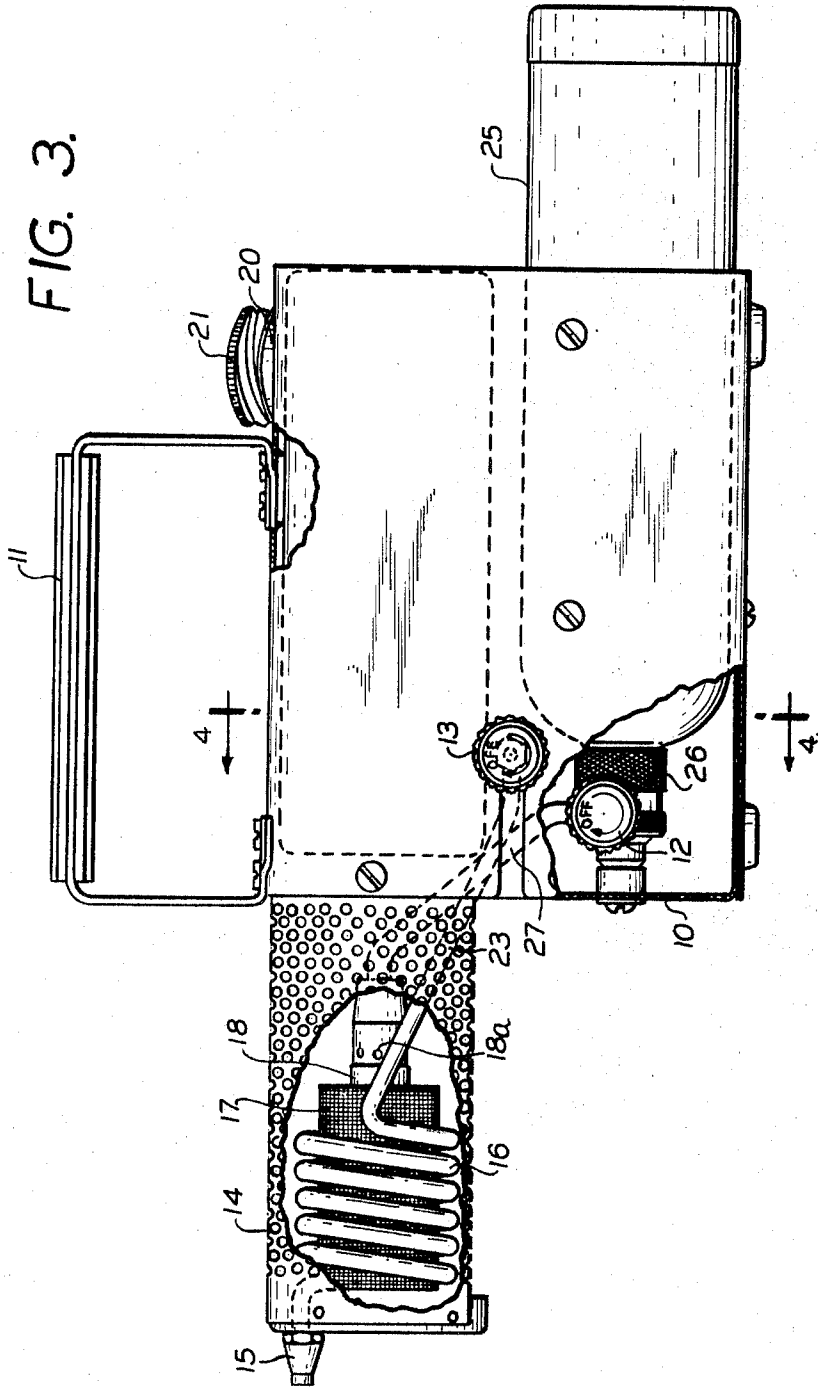

INSECTICIDAL JET FOGGER

Devices for dispensing very fine fogs of an oil carrying an insecticide such as DDT have come into wide use. In one type a liquid insecticidal oil is heated in a coil under pressure and then ejected through a nozzle, the oil forming a fine fog when it is discharged into the air.

Such fogging devices are a fast, economical and easy way to clear relatively large areas of insects such as flies and mosquitos. There has been a need for a compact light weight easy to use fogging unit for home applications such as for patios, swimming pools and lawns.

The present invention proposes such a design characterized by the fact that the insecticide tank, the L. P. gas cartridge and the dispensing nozzle-guard-burner unit are substantially in alignment to give a compact structure that is readily portable and easily aimed to direct the fog.

THE DRAWINGS

- FIG. 1 is a perspective view of the jet fogger;
FIG. 2 is an end view looking at the end into which the L. P. tank is inserted;
FIG. 3 is a side view of the jet fogger partly broken away to show some of the operating features; and
FIG. 4 is a cross section elevational view taken along line 4-4 of FIG. 3.

DESCRIPTION

With reference to the drawing the jet fogger comprises a housing 10 having a carrying handle 11 from which protrudes two control knobs, 12 and 13, for turning on and off, and controlling, the action of the burner and the dispensing of the insecticide, respectively. Attached to one end of the housing and in general alignment with the housing is a guard 14 which projects somewhat like the barrel of a gun. The guard ends in a dispensing nozzle 15 and contains interiorly a vaporizing coil 16 which connects with nozzle 15, within which is a burner cage 17 about a propane burner 18. The burner cage serves to convert a significant portion of gas energy into radiant heat.

Housing 10 contains a cylindrical tank 19 for containing the insecticidal oil. The tank has a filling neck 20 which when not in use may be capped with cap 21. However, as shown in FIG. 2, a hand pump 22 is designed to be threaded onto the neck 20 when the cap 21 is removed so that the contents of tank 19 can be pressurized. Tank 19 is connected with coil 16 by line 23 which contains valve 24 having valve handle 13.

The lower portion of housing 10 is designed to accommodate a standard L. P. gas disposable cartridge 25 (not shown in FIGS. 1, 2 and 4) in general alignment with the longitudinal axis of the cylindrical insecticidal oil tank 19 and immediately below the tank. The housing on the end wall opposite from the point of insertion of cartridge 25 has a gas valve 26 adapted to threadably engage the neck of cylinder 25, valve 26 has a rod or activating plunger 26a to open the valve of cartridge 25. Valve 26 has valve handle 12 which extends through the housing as shown. The valve is connected to the burner head 18 by line 27. It will be noted that both lines

23 and 27 lie within the housing and the guard 14.

In operation, the tank is filled through inlet 20, hand pump 22 is attached and the contents of the tank are pressurized. The L. P. gas cartridge 25 is inserted and threaded into valve 26, valve 26 is turned on by means of knob 12, which is finger adjustable, and the burner is lit as by inserting a match through an opening 14a in guard 14 near the rear of the burner cage. Valve 24 is then turned on to start the flow of the oil to coil 16 and the oil having passed through coil 16 issues as a dense fog from nozzle 15.

For a unit having an operating time of about one-half hour, the housing may have a height of about 9- 3/4 of an inch and a length including the cylinder of 18- 1/4 inches. The capacity of the oil tank can be about 22 ounces and that of the disposable gas cartridge about 14 ounces, by weight. This size of the device will give a fogging rate of about 10,00 cubic feet per minute.

What is claimed is:

- 1. A hand held and operated device for dispensing an insecticidal oil fog, comprising:
a. a housing adapted to be hand carried having a guard extending therefrom in alignment with its axis;
b. a cylindrical tank within the upper portion of said housing and adapted to contain a vaporizable liquid insecticidal fogging oil under pressure, said tank having in its upper portion a threaded inlet extending through said housing;
c. L.P. valve means adapted to receive and activate a L.P. gas cartridge in the lower portion of said housing by inserting the same through one end of said housing in alignment with the longitudinal axis of said cylindrical tank, said L.P. valve means including a shut off and control valve the handle of which is finger adjustable and extends through said housing;
d. a vaporizer coil within said guard and terminating in a dispensing nozzle projecting from the end of said guard;
e. a burner within said coil adapted to heat and said vaporizer coil being adapted when heated to vaporize said liquid insecticidal fogging oil in said coil and project the same through said dispensing nozzle;
f. a burner cage between said burner and said coil adapted to convert a significant portion of gas energy into radiant heat;
g. a feed line lying within said housing and guard and connecting said coil and the lower portion of said cylindrical tank, said feed line having a shut off and control valve the handle of which is finger adjustable and extends through said housing contiguous to the handle of said L.P. valve means; and
h. a fuel line lying within said housing and guard, and connecting said burner and said L.P. valve means.
2. The device of claim 1 wherein the upper portion of said housing is curved to mate with said cylindrical tank and flows downwardly therefrom to a wider base.
3. The device of claim 1 including in addition a hand pump adapted to be mounted on said threaded inlet and to pressurize said cylindrical tank.

\* \* \* \* \*

60

65

70

75