



- (51) **International Patent Classification:**
C10G 11/18 (2006.01) *B01J 8/38* (2006.01)
B01J 8/26 (2006.01)
- (21) **International Application Number:** PCT/IB2012/057684
- (22) **International Filing Date:** 24 December 2012 (24.12.2012)
- (25) **Filing Language:** English
- (26) **Publication Language:** English
- (30) **Priority Data:** 336/KOL/2012 27 March 2012 (27.03.2012) IN
- (71) **Applicant:** **INDIAN OIL CORPORATION LTD.** [IN/IN]; Indian Oil Bhavan, 2, Gariahat Road (South), Dhakuria, West Bengal, Kolkata 700068 (IN).
- (72) **Inventors:** **SADHULLAH, Mukthiyar;** c/o. Indian Oil Corporation Ltd., Research & Development Centre, Sector-13, Haryana, Faridabad 121007 (IN). **KUMARAN, Sathesh, Vetterkunnel;** c/o. Indian Oil Corporation Ltd., Research & Development Centre, Sector-13, Haryana, Faridabad 121007 (IN). **BHATTACHARYA, Debasis;** c/o. Indian Oil Corporation Ltd., Research & Development Centre, Sector-13, Haryana, Faridabad, 121007 (IN). **SAIDULU, Gadari;** c/o. Indian Oil Corporation Ltd., Research & Development Centre, Sector-13, Haryana, Faridabad 121007 (IN). **KUKADE, Somnath;** c/o. Indian

Oil Corporation Ltd., Research & Development Centre, Sector-13, Haryana, Faridabad 121007 (IN). **KUMAR, Brijesh;** c/o. Indian Oil Corporation Ltd., Research & Development Centre, Sector-13, Haryana, Faridabad 121007 (IN). **RAJAGOPAL, Santanam;** c/o. Indian Oil Corporation Ltd., Research & Development Centre, Sector-13, Haryana, Faridabad 121007 (IN).

- (74) **Agent:** **NAIR, Manisha, Singh;** LEX ORBIS Intellectual Property Practice, 709/710, Tolstoy House, 15 - 17, Tolstoy Marg, New Delhi 110 001 (IN).
- (81) **Designated States** (*unless otherwise indicated, for every kind of national protection available*): AE, AG, AL, AM, AO, AT, AU, AZ, BA, BB, BG, BH, BN, BR, BW, BY, BZ, CA, CH, CL, CN, CO, CR, CU, CZ, DE, DK, DM, DO, DZ, EC, EE, EG, ES, FI, GB, GD, GE, GH, GM, GT, HN, HR, HU, ID, IL, IN, IS, JP, KE, KG, KM, KN, KP, KR, KZ, LA, LC, LK, LR, LS, LT, LU, LY, MA, MD, ME, MG, MK, MN, MW, MX, MY, MZ, NA, NG, NI, NO, NZ, OM, PA, PE, PG, PH, PL, PT, QA, RO, RS, RU, RW, SC, SD, SE, SG, SK, SL, SM, ST, SV, SY, TH, TJ, TM, TN, TR, TT, TZ, UA, UG, US, UZ, VC, VN, ZA, ZM, ZW.
- (84) **Designated States** (*unless otherwise indicated, for every kind of regional protection available*): ARIPO (BW, GH, GM, KE, LR, LS, MW, MZ, NA, RW, SD, SL, SZ, TZ, UG, ZM, ZW), Eurasian (AM, AZ, BY, KG, KZ, RU, TJ, TM), European (AL, AT, BE, BG, CH, CY, CZ, DE, DK,

[Continued on next page]

(54) **Title:** AN APPARATUS AND A PROCESS FOR FLUID CATALYTIC CRACKING

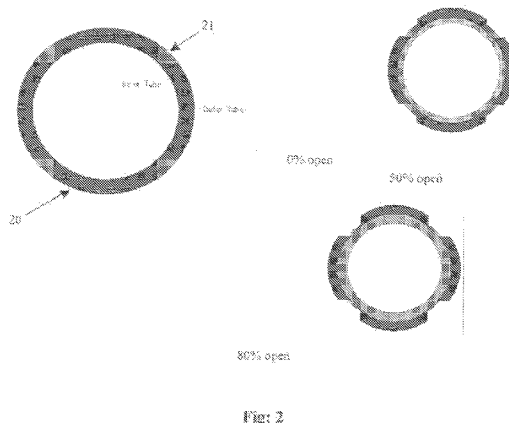

(57) **Abstract:** An apparatus which is an integral hardware consisting of an annular downer reactor and a concentric upflow riser regenerator for catalytic cracking of hydrocarbon feed to is disclosed. The annular downer reactor terminates in annular stripper which is also concentric with the regenerator. The regenerator, reactor and stripper are in fluid connection with each other. The apparatus is highly compact and provides efficient contact between circulating catalyst and hydrocarbon feed. The proposed hardware includes a novel radial distributor for providing improved control and radial distribution of catalyst inside the downflow reactor. The radial distributor has equal numbers of stationary and movable parts placed one after another to cover the entire annular opening at the bottom of the regenerated catalyst vessel. The radial distributor is concentric with regenerator and located between the catalyst holding vessel and the reactor. A process for catalytic cracking using the invented apparatus is also disclosed.



EE, ES, FI, FR, GB, GR, HR, HU, IE, IS, IT, LT, LU,
LV, MC, MK, MT, NL, NO, PL, PT, RO, RS, SE, SI, SK,
SM, TR), OAPI (BF, BJ, CF, CG, CI, CM, GA, GN, GQ,
GW, ML, MR, NE, SN, TD, TG).

— *as to the applicant's entitlement to claim the priority of
the earlier application (Rule 4.17(iii))*

Published:

— *with international search report (Art. 21(3))*

Declarations under Rule 4.17:

— *as to applicant's entitlement to apply for and be granted
a patent (Rule 4.17(ii))*

AN APPARATUS AND A PROCESS FOR FLUID CATALYTIC CRACKING

FIELD OF THE INVENTION

The present invention relates to an improved process and an apparatus for catalytic cracking of hydrocarbon feed for production of valuable lighter products. More particularly, it relates to a fluid catalytic cracking process and apparatus employing an annular downer reactor equipped with a novel design of catalyst distributor to provide efficient contact between the circulating catalyst and the hydrocarbon feed.

BACKGROUND AND PRIOR ART OF THE INVENTION

Fluid Catalytic Cracking (FCC) is one of the most important secondary conversion processes to convert the high-boiling, high-molecular weight hydrocarbon fractions to valuable products such as LPG, gasoline, and middle distillates. This process provides flexibility to maximize the product of interest through operation under different modes.

The conversion section of FCC unit consists of riser, reactor, stripper, regenerator and hardware internals. As the price of petroleum crudes has been increasing, more and more emphasis has been given on increasing the efficiency of the catalytic cracking process so that the end product can be more competitively priced. As a result, in the recent past, down flow reactor has been introduced to improve the product selectivity. **US Patent 4385985** discloses downflow reactor for FCC process claiming it to be better compared to the upflow riser with respect to coke make, distribution of catalyst and decrease in contact time.

In down flow reactor, the catalyst along with the hydrocarbon vapors flow downwards and the slip velocity between the catalyst flow and the hydrocarbon flow is lower than that of the riser reactor resulting in reduced coke formation and higher distillate yield. Although the downflow reactor is said to have superior flow characteristics in comparison to the riser, the main challenge remains the distribution of the catalyst at the initial section of the down flow reactor where it is contacted with hot hydrocarbon feed. Moreover, the radial distribution of the catalyst in a downflow reactor deteriorates with increase in diameter.

Accordingly, Qi.et.al (1990) proposes a configuration where the gas solid flow after the riser is not separated but enters directly to the downer through a sharp 90° bend or smooth connection. Cao.et.al (1994) proposes a fluidized bed feeder designed to Pthe

solids at the downer inlet. Solids are fluidized uniformly above the downer inlet and flow through several tubes into the downer.

US Patent 6200534 discloses a first circulating fluidized bed reactor surrounded by a second circulating fluidized bed reactor which is concentric to the first. The invention, however, is directed at reducing the footprint/space requirement of the equipment. Many chemical processes involve two separate catalytic or even physical processes. The design of the reactor combines two such processes within the same device, thereby achieving the goal of space saving.

US Patent 5,468,369 discloses a process and apparatus for short contact time fluidized catalytic cracking of heavy oil feed using a reactor with upflow cat:oil vaporizer and downflow reactors. It is claimed that efficient catalyst oil mixing with limited conversion is achieved in the upflow section and the cracking reactions are completed in the downflow section.

US Patent No 5296131 discloses a concept of falling curtain of catalyst which is claimed to provide maximum exposure of catalyst to oil and difficult to control the flow. This patent describes about the annular curtain of downward flowing solids with flow controlled through a plug valve mechanism placed in the flow path of the catalyst. The option of feed injection with at least one part of the feed is injected toward the bottom through a radial opening under the seat of plug valve has been provided.

US Patent No 4814067, 4919898, 5098672 and 6482312 B1 DIS disclosed by SWEC illustrates the formation of falling annular curtain from rectangular openings provided in a bed pressurized by steam. This patent describes the injection of feed in the direction of valve forming the curtain. This technique suffers from the solids flow control through the pressure difference. As for small pressure difference can cause in wide variation of flow which shall ultimately result in wide variation of selectivity.

From the above analysis of prior art, it is found that there is no disclosure of a compact integral hardware consisting of an annular curtain flow reactor to provide an efficient contact between circulating catalyst and hydrocarbon feed and efficient control of the same. The present invention discloses a process and apparatus for improved contact of catalyst and hydrocarbon feed leading to improved conversion and product selectivity. The apparatus in the current invention mainly comprises of radial distributor for catalyst and an annular downer reactor.

OBJECTS OF THE INVENTION

An object of the invention is to provide an integral hardware consisting of an annular downer reactor and an upflow riser regenerator for catalytic cracking of hydrocarbon feed.

5 A further object of the invention is to provide apparatus for radial distribution of the catalyst in an annular downer reactor.

Yet another object of the invention is to provide a unique radial catalyst distributor for achieving maximum contact between circulating catalyst.

10 Yet another object of the invention is to provide efficient contact between circulating catalyst and hydrocarbon feed.

Another object of the invention is to provide a highly compact apparatus.

SUMMARY OF THE INVENTION

The apparatus of the current invention is an integral hardware consisting of an annular downer reactor for catalytic cracking of hydrocarbon feed and an upflow riser regenerator for burning off the coke deposited on the catalyst. The upflow riser
15 regenerator has circular cross section and is surrounded by a concentric downflow reactor which terminates in annular stripper. The regenerator, reactor and stripper are in fluid connection with each other.

This configuration is highly compact and provides efficient contact between
20 circulating catalyst and hydrocarbon feed. The proposed hardware includes a novel radial distributor for providing improved radial distribution of catalyst into the annular downer reactor. The radial distributor has equal numbers of stationary and movable parts placed one after another to cover the entire opening at the inlet of annular downer reactor. It is placed concentric with regenerator and located between the regenerated catalyst holding
25 vessel and the annular downer reactor.

BRIEF DESCRIPTION OF THE ACCOMPANYING DRAWING

Fig. 1 is a schematic representation of the apparatus for fluid catalytic cracking according to the invention.

Fig. 2 is a plan view of section A-A in Fig.1 showing the radial distributor.

30 **Fig. 3** shows the geometric details of the stationary section of the distributor.

DETAILED DESCRIPTION OF THE INVENTION

The proposed apparatus is an integral hardware consisting of an annular downer reactor and an upflow riser regenerator for catalytic cracking of hydrocarbon feed to valuable lighter products. The advantage of this configuration is that its design is highly compact and provides efficient contact between circulating catalyst and hydrocarbon feed. The schematic of the apparatus is given in Figure 1. The radial distribution of the catalyst in a downflow reactor deteriorates as the diameter increases. To mitigate this, annular curtain flow design with the novel radial distributor for providing improved radial distribution of catalyst into the annular downer reactor is proposed. The schematic of the radial distributor is given in Figure 2.

The Apparatus

The apparatus according to this invention for fluid catalytic cracking comprising of reactor, regenerator and stripper is described in a sequential manner below. The apparatus is best seen in Figure 1.

An annular downer reactor (5) is placed concentric to the upflow regenerator (16) with circular cross section which terminates in annular stripper (6) placed at the bottom. The stripper is concentric with the regenerator. The regenerator, reactor and stripper are in fluid connection with each other. Multiple conduits (11) equipped with individual slide valves (12) are provided between stripper and regenerator for flow and control of catalyst from stripper to regenerator. A regenerated catalyst holding vessel (1) is positioned at the top of the annular downer reactor which contains the regenerator termination device (17).

A radial catalyst distributor (3) is placed concentric with the regenerator and is located between catalyst holding vessel (1) and reactor (5). The detailed description of the distributor is provided in the following section.

An angular deflector plate (4) with an angle of inclination varying between 30° to 80° with the horizontal is located below the catalyst distributor, along the outer circumference of regenerator.

Radial Catalyst Distributor

The radial catalyst distributor (3) is designed for efficient distribution and control of catalyst flow into the annular downer reactor.

- a. This distributor consists of two types of parts, stationary and moving.

- b. The stationary part (21) is a section of annulus and has the shape of circular sector of any particular vertex angle (angle calculated based on the number of stationary part required).
- c. The moving part (20) is a section of annulus and has two parallel sides which can move between the edges of two stationary parts.
- d. There are equal numbers of stationary and movable parts placed one after another to cover the entire annular opening. For illustration, four stationary parts (pink color) and four moving parts (blue colour) are considered in Figure 2. The vertex angle of the stationary parts in this case is 90° . It is possible to move the rectangular strips in to and fro manner. This will create a variable flow area for the catalyst. The green colour shows the opening created for catalyst flow. It also acts as a control valve for regulating the catalyst flow from the regenerated catalyst holding vessel to the annular downer reactor.

The percentage of annular area for catalyst flow increases as the number of stationary and moving parts increase. The catalyst flow area available is minimum when there are two stationary and moving parts and reaches a maximum value for infinite number of stationary and moving parts. The percentage increase of annular area for catalyst flow is less than 0.3% when the stationary and moving parts are more than 6 number. The area of stationary and area of catalyst flow is given in Table 1 below using riser outer diameter of 1.6 m and distributor outer diameter of 1.8 m. It can also be seen that the area for catalyst flow is not only affected with the number of stationary and moving parts of the distributor but also with the variation in outer diameter of the riser regenerator and catalyst distributor. The detail about the calculation on stationary part is given in Figure 3.

25

Table 1

No of stationary Divisions	Area of the stationary section (m²)	Percentage area for catalyst flow (%)
2	0.111	79.17
4	0.039	92.77
6	0.034	93.59
8	0.033	93.83
12	0.032	94.00

∞	0.031	94.12
----------	-------	-------

The Process

The regenerated FCC catalyst from the regenerator (16) is collected in regenerated catalyst holding vessel (1) situated at the top of the annular downer reactor (5). The catalyst enters into the annular downer reactor through a radial flow catalyst distributor (3) placed at the bottom of regenerated catalyst vessel (1).

The pre-accelerated catalyst then falls on an angular plate (4) placed around the outer circumference of the upflow regenerator to form a uniform curtain flow. The catalyst flows downwards in the form of curtains through annular downer reactor (5). The hydrocarbon feed is injected into the curtain of catalyst just below the deflector plate using feed injectors (20). These feed injectors are located circumferentially at equidistant locations at outer circumference of annular downer reactor. The catalyst and the vaporized feed moves down through the annular downer reactor (5) and cracking reactions takes place with a very short residence time. The residence time in the downflow reactor may vary between 0.1-2 seconds. The cracked gases alongwith the spent catalyst enter into the stripper (6) where the products and the catalyst are separated through suitable separation device. The catalyst is stripped using steam in stripper (6) to remove the entrapped hydrocarbons inside the catalyst pores. The entrained catalyst fines are separated from product hydrocarbon vapors and steam by the use of two stage cyclone separators (8, 9) or any suitable separation device. The present invention is not limited to the usage of this separation device. The spent catalyst after steam stripping enters into the upflow riser regenerator (16) through the standpipes (11). The catalyst flow is controlled by a slide valve (12) located on this stand pipe. The catalyst is regenerated in the upflow regenerator operated at the fast fluidized regime to ensure coke on regenerated catalyst below 0.1 wt%. The catalyst residence time provided in the upflow regenerator may vary from 5-60 seconds. The entrained catalyst fines are separated from the flue gas by the use of two stages of cyclone separators (18, 19) or any suitable separation device. The present invention is not limited to the usage of this separation device.

Advantages of the proposed apparatus:

1. The downflow reactor contact efficiency between circulating catalyst and hydrocarbon feed is maximum when the catalyst is dispersed in to the down flow

reactor in the form of annular curtains. The proposed apparatus provides an annular curtain without compromising on the central tubular area which is used for regeneration of the spent catalyst.

2. The radial catalyst distributor (3) generates the required uniform circumferential flow into the annular downer reactor.
3. The present apparatus requires less plot area, minimum hardware and catalyst inventory due to its highly compact design.
4. Moreover, this apparatus does away with the long stand pipe operation which is normal in fluid bed catalytic cracking.

Other embodiments:

- a. The inner upflow riser (16) may be used as lift line and the vessel (1) is used as regenerator, which may be operated either under partial or full combustion mode.
- b. The apparatus of the present invention can be used for performing simultaneous pyrolysis and gasification reactions, where the pyrolysis is done in annular downer reactor and the gasification of the resulting char from pyrolysis in upflow riser.
- c. The inner upflow riser may be used for cracking reaction, vessel (1) as stripper and the annular downer (5) as regenerator and the stripper (6) as regenerator.

The embodiments of the invention disclosed herein are only illustrative. There can be several other possible embodiments of the invention also fall within the scope of this invention as would be apparent from the practice of the invention. The full scope and spirit of the invention should be derived from the following appended claims.

We Claim:

1. An apparatus for fluid catalytic cracking of hydrocarbon feed comprising of:
 - (a) an annular downer reactor (5), concentric with an up-flow regenerator (16) of circular cross section, which terminates in annular stripper (6), the stripper
5 being concentric with the regenerator and the regenerator, reactor and stripper being in fluid connection with each other;
 - (b) a plurality of conduits (11) equipped with individual slide valve (12) positioned between the stripper and the regenerator;
 - (c) a catalyst holding vessel (1) positioned at the top of the reactor containing the
10 regenerator termination device (17);
 - (d) a radial catalyst distributor (3) is positioned concentric with the upflow regenerator and located between the regenerated catalyst holding vessel (1) and the annular downer reactor (5); and
 - (e) an angular deflector plate (4) with an angle of inclination varying between 30°
15 to 80° with horizontal and located below the catalyst distributor (3) and along the outer circumference of the up flow regenerator, to generate a curtain flow of catalyst into the annular downer reactor.
2. The apparatus as claimed in claim 1, wherein the radial catalyst distributor (3) controls the uniform circumferential catalyst flow into the reactor.
- 20 3. The apparatus as claimed in claim 1, wherein the radial catalyst distributor (3) comprises of one or more stationary (21) and moving (20) parts.
4. The apparatus as claimed in claim 3, wherein the number of moving parts (20) is equal to the number of stationary parts (21).

5. The apparatus as claimed in claim 3, wherein the stationary part (21) having a shape of a circular sector of a particular vertex angle calculated based on the number of stationary parts required.
6. The apparatus as claimed in claim 3, wherein moving part (20) is a section of
5 annulus with two sides parallel and moving parallel to the edges of two adjacent stationary parts.
7. The apparatus as claimed in claims 1 to 6, wherein the up-flow regenerator (16) is used as lift line and the catalyst holding vessel (1) is used as regenerator, operated either under partial or full combustion mode.
- 10 8. The apparatus as claimed in claims 1 to 6, wherein the apparatus can be used for performing simultaneous pyrolysis and gasification reactions.
9. The apparatus as claimed in claims 8, wherein the pyrolysis is done in the down-flow reactor (5) and the gasification of the resulting char from pyrolysis is done in the up-flow regenerator (16).
- 15 10. The apparatus as claimed in claims 1 to 6, wherein the up-flow regenerator (16) can be used for cracking reaction, catalyst holding vessel (1) can be used as the stripper, the down-flow reactor (5) can be used as a regenerator and the stripper (6) can be used as the regenerator.
11. The apparatus as claimed in claims 1 provides an annular downer reactor without
20 compromising on the central tubular area which is used for regeneration of the spent catalyst.
12. A process for catalytic cracking of hydrocarbon using an apparatus as claimed in claim 1 to 10, said process comprising:

- (a) collecting the regenerated FCC catalyst from the up-flow regenerator (16) in the catalyst holding vessel (1),
- (b) controlling the uniform circumferential catalyst flow into the annular downer reactor by radial distributor (3)
- 5 (c) allowing the uniform circumferential catalyst flow to fall on the angular deflector plate (4) to form a curtain flow of catalyst in to the annular reactor (5),
- (d) injecting the hydrocarbon feed along with a diluent preferably steam into the curtain flow of catalyst just below the deflector plate using feed injectors (20)
- 10 and allow the catalyst, diluent and the feed to move down through the annular downer reactor (5),
- (e) recovering the hydrocarbon vapours entrapped in the catalyst pores by the use of steam in the stripper (6)
- (f) separating the hydrocarbon vapours and diluent/steam from the spent catalyst
- 15 in the stripper (6) using a suitable separation device such as cyclone separator , and
- (g) returning the spent catalyst to the regenerator (16) with the help of one or more conduits (11) equipped with individual slide valves (12).
13. The process as claimed in claim 12, wherein the catalyst has residence time
- 20 between 5 to 60 seconds in the up-flow regenerator (16).
14. The process as claimed in claim 12, wherein the catalyst and the feed have residence time between 0.1 to 2 second in the annular downer reactor (5).

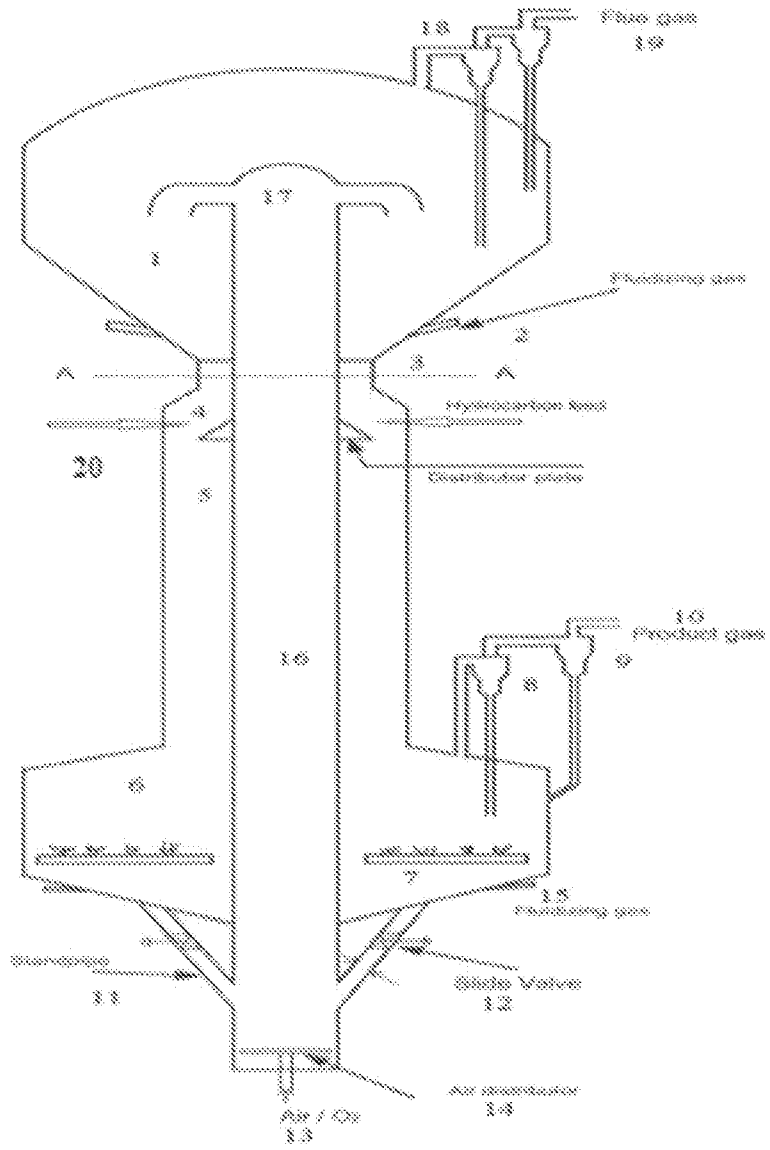

Fig: 1

2/3

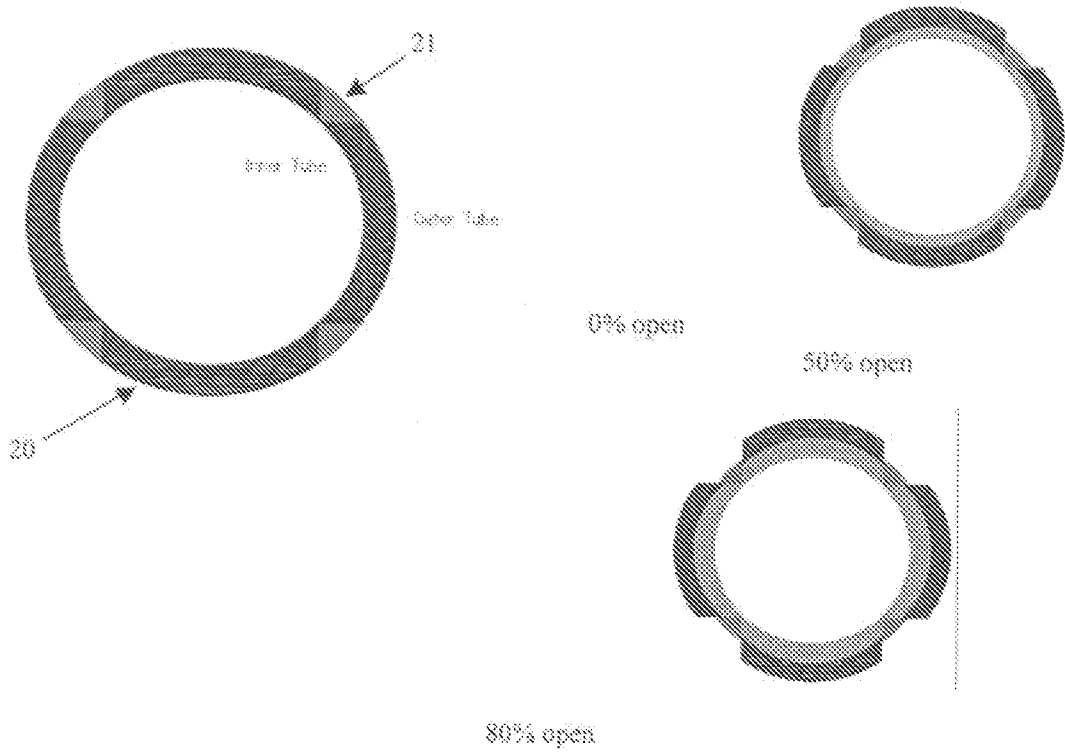
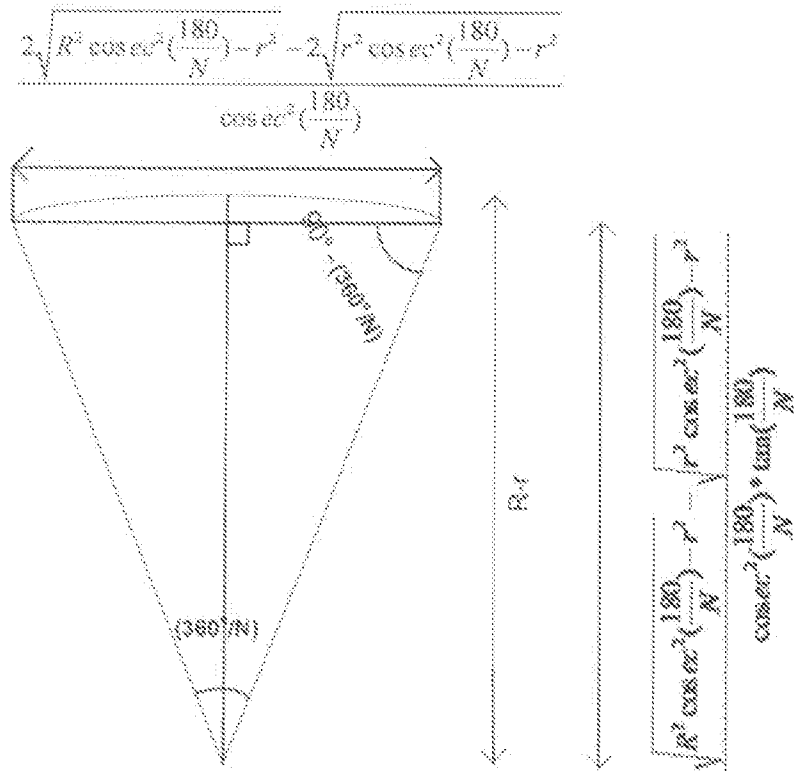

Fig: 2



N -- Number of stationary / movable parts
 R -- Outer radius of catalyst distributor
 r -- Outer radius of riser (inner pipe)

Fig: 3

INTERNATIONAL SEARCH REPORT

International application No
PCT/IB2012/057684

A. CLASSIFICATION OF SUBJECT MATTER
INV. C10G11/18 B01J8/26 B01J8/38
ADD.
According to International Patent Classification (IPC) or to both national classification and IPC

B. FIELDS SEARCHED
Minimum documentation searched (classification system followed by classification symbols)
C10G B01J

Documentation searched other than minimum documentation to the extent that such documents are included in the fields searched

Electronic data base consulted during the international search (name of data base and, where practicable, search terms used)
EPO-Internal, WPI Data

C. DOCUMENTS CONSIDERED TO BE RELEVANT

Category*	Citation of document, with indication, where appropriate, of the relevant passages	Relevant to claim No.
X	DE 24 49 346 A1 (TEXACO DEVELOPMENT CORP) 29 April 1976 (1976-04-29) figure 1	1-11
X	US 5 296 131 A (RATERMAN MICHAEL F [US]) 22 March 1994 (1994-03-22) cited in the application column 9, line 29 - line 36; claim 1; figure 2	1-14

Further documents are listed in the continuation of Box C.

See patent family annex.

* Special categories of cited documents :

- "A" document defining the general state of the art which is not considered to be of particular relevance
- "E" earlier application or patent but published on or after the international filing date
- "L" document which may throw doubts on priority claim(s) or which is cited to establish the publication date of another citation or other special reason (as specified)
- "O" document referring to an oral disclosure, use, exhibition or other means
- "P" document published prior to the international filing date but later than the priority date claimed

- "T" later document published after the international filing date or priority date and not in conflict with the application but cited to understand the principle or theory underlying the invention
- "X" document of particular relevance; the claimed invention cannot be considered novel or cannot be considered to involve an inventive step when the document is taken alone
- "Y" document of particular relevance; the claimed invention cannot be considered to involve an inventive step when the document is combined with one or more other such documents, such combination being obvious to a person skilled in the art
- "&" document member of the same patent family

Date of the actual completion of the international search 13 May 2013	Date of mailing of the international search report 17/05/2013
---	---

Name and mailing address of the ISA/ European Patent Office, P.B. 5818 Patentlaan 2 NL - 2280 HV Rijswijk Tel. (+31-70) 340-2040, Fax: (+31-70) 340-3016	Authorized officer Deurinck, Patricia
--	---

INTERNATIONAL SEARCH REPORT

Information on patent family members

International application No

PCT/IB2012/057684

Patent document cited in search report	Publication date	Patent family member(s)	Publication date
DE 2449346	A1	NONE	29-04-1976
US 5296131	A	NONE	22-03-1994