

(19)



(11)

EP 2 302 147 A3

(12)

EUROPEAN PATENT APPLICATION

(88) Date of publication A3:
27.04.2011 Bulletin 2011/17

(51) Int Cl.:
E04D 13/068^(2006.01)

(43) Date of publication A2:
30.03.2011 Bulletin 2011/13

(21) Application number: **10178104.5**

(22) Date of filing: **21.09.2010**

(84) Designated Contracting States:
AL AT BE BG CH CY CZ DE DK EE ES FI FR GB GR HR HU IE IS IT LI LT LU LV MC MK MT NL NO PL PT RO SE SI SK SM TR
 Designated Extension States:
BA ME RS

(72) Inventor: **Wereszczynski, Zbigniew Zygmunt Kent, ME17 2DE (GB)**

(74) Representative: **Hall, Matthew Benjamin Dehns St. Bride's House 10 Salisbury Square London EC4Y 8JD (GB)**

(30) Priority: **21.09.2009 GB 0916605**

(71) Applicant: **DHM Plastics Limited Maidstone, Kent ME17 2DE (GB)**

(54) Metal gutter system with improved gutter joint

(57) A gutter system is described having a gutter joint where a first metal gutter component, comprising a length of metal gutter (1), is joined to a union (10), the components overlapping at the gutter joint and the gutter joint further having a strip of resilient material (30) that extends transversely to the metal gutter (1) and is sandwiched

between adjacent overlapping surfaces of the gutter components, wherein the union (10) is provided with a channel for holding a sealant retaining portion of the strip (30) in place, and further wherein the sealant retaining portion of the strip (30) comprises a track (31) that is arranged to be filled with a bead of sealant prior to joining the gutter components together to form the gutter joint.

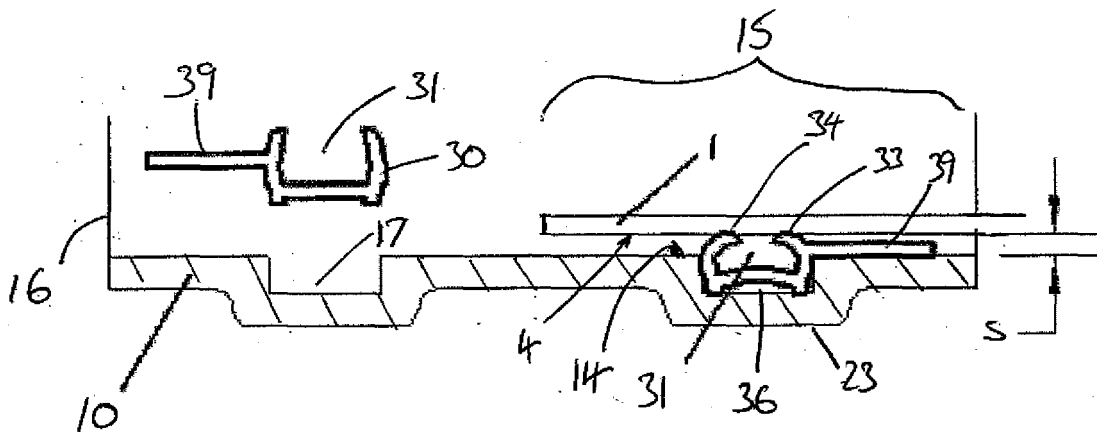

Fig. 6

EP 2 302 147 A3



PARTIAL EUROPEAN SEARCH REPORT

Application Number

under Rule 62a and/or 63 of the European Patent Convention.
This report shall be considered, for the purposes of subsequent proceedings, as the European search report

EP 10 17 8104

DOCUMENTS CONSIDERED TO BE RELEVANT			
Category	Citation of document with indication, where appropriate, of relevant passages	Relevant to claim	CLASSIFICATION OF THE APPLICATION (IPC)
X	GB 2 193 982 A (ALLFOR INVESTMENT LIMITED) 24 February 1988 (1988-02-24)	1,4,8	INV. E04D13/068
Y	* page 1, line 7 - line 13 * * page 2, line 91 - page 3, line 61; figure 1 *	2,5-7,9, 10,13-15	
X	GB 2 026 058 A (PRE FORMED COMPONENTS LTD) 30 January 1980 (1980-01-30)	1,3,4	
Y	* page 1, line 117 - line 126 * * page 2, line 52 - page 3, line 85; figures 1-6 *	2,5-7,9, 10,13-15	
Y	FR 2 533 958 A1 (AMBROISE CASTEROT FRANCIS [FR]) 6 April 1984 (1984-04-06) * page 3, line 37 - page 5, line 24; figures 1-3 *	13-15	
Y	GB 1 603 819 A (WAVIN BV) 2 December 1981 (1981-12-02) * page 1, line 35 - page 2, line 50; figures 1-3 *	2,6	TECHNICAL FIELDS SEARCHED (IPC)
			E04D
INCOMPLETE SEARCH			
The Search Division considers that the present application, or one or more of its claims, does/do not comply with the EPC so that only a partial search (R.62a, 63) has been carried out.			
Claims searched completely :			
Claims searched incompletely :			
Claims not searched :			
Reason for the limitation of the search: see sheet C			
Place of search Munich		Date of completion of the search 7 March 2011	Examiner Giannakou, Evangelia
CATEGORY OF CITED DOCUMENTS		T : theory or principle underlying the invention E : earlier patent document, but published on, or after the filing date D : document cited in the application L : document cited for other reasons & : member of the same patent family, corresponding document	
X : particularly relevant if taken alone Y : particularly relevant if combined with another document of the same category A : technological background O : non-written disclosure P : intermediate document			

1 EPO FORM 1503 03/82 (P04E07)



PARTIAL EUROPEAN SEARCH REPORT

Application Number
EP 10 17 8104

DOCUMENTS CONSIDERED TO BE RELEVANT			CLASSIFICATION OF THE APPLICATION (IPC)
Category	Citation of document with indication, where appropriate, of relevant passages	Relevant to claim	
Y	DE 42 02 136 A1 (ARLT GERHARD [DE]) 13 August 1992 (1992-08-13) * page 6, line 45 - line 48 * -----	5	
Y	GB 2 372 762 A (MARLEY EXTRUSIONS [GB]) 4 September 2002 (2002-09-04) * page 1, line 5 - line 8 * * page 5, line 36 - page 7, line 8; figures 1,2a,2b, 2c, 3, * -----	7,9,15	
Y	US 4 327 051 A (EDMONDSON RONALD) 27 April 1982 (1982-04-27) * column 1, line 33 - line 41 * * column 3, line 56 - column 4, line 39; figures 2,3,4 * -----	7,9,10, 15	
			TECHNICAL FIELDS SEARCHED (IPC)

**INCOMPLETE SEARCH
SHEET C**Application Number
EP 10 17 8104

Claim(s) completely searchable:
1-10, 13-15

Claim(s) not searched:
11, 12

Reason for the limitation of the search:

In reply to the invitation to indicate the claims on which the search is to be based, the applicant failed to supply the requested indication in due time.

Thus, the search report has been drawn up on the basis of the first independent claim of each category (Rule 62a(1) EPC), namely claim 1 and 13.

The applicant's attention is drawn to the fact that the application will be further prosecuted on the basis of subject-matter for which a search has been carried out and that the claims should be limited to that subject-matter at a later stage of the proceedings (Rule 62a(2) EPC).

**ANNEX TO THE EUROPEAN SEARCH REPORT
ON EUROPEAN PATENT APPLICATION NO.**

EP 10 17 8104

This annex lists the patent family members relating to the patent documents cited in the above-mentioned European search report. The members are as contained in the European Patent Office EDP file on
The European Patent Office is in no way liable for these particulars which are merely given for the purpose of information.

07-03-2011

Patent document cited in search report		Publication date	Patent family member(s)	Publication date
GB 2193982	A	24-02-1988	NONE	

GB 2026058	A	30-01-1980	NONE	

FR 2533958	A1	06-04-1984	NONE	

GB 1603819	A	02-12-1981	NONE	

DE 4202136	A1	13-08-1992	NONE	

GB 2372762	A	04-09-2002	NONE	

US 4327051	A	27-04-1982	NONE	

EPO FORM P0489

For more details about this annex : see Official Journal of the European Patent Office, No. 12/82