



US00D614112S

(12) **United States Design Patent**  
**Tant et al.**

(10) **Patent No.:** **US D614,112 S**

(45) **Date of Patent:** **\*\* Apr. 20, 2010**

(54) **VEHICLE WHEEL**

(75) Inventors: **Sean William Tant**, Livonia, MI (US);  
**Patrick J. Schiavone**, Bloomfield, MI  
(US); **George Bucher**, Dearborn, MI  
(US)

(73) Assignee: **Ford Motor Company**, Dearborn, MI  
(US)

(\*\*) Term: **14 Years**

(21) Appl. No.: **29/323,627**

(22) Filed: **Aug. 28, 2008**

(51) **LOC (9) Cl.** ..... **12-16**

(52) **U.S. Cl.** ..... **D12/211**

(58) **Field of Classification Search** ..... D12/204–213;  
301/37.101, 64.101, 65

See application file for complete search history.

(56) **References Cited**

**U.S. PATENT DOCUMENTS**

D482,647 S *	11/2003	Lecher et al.	.....	D12/211
D487,717 S *	3/2004	Lenz	.....	D12/211
D516,002 S *	2/2006	Fahr-Becker	.....	D12/211
D519,899 S	5/2006	Metros		
D520,432 S	5/2006	Metros		
D522,432 S *	6/2006	Pfeiffer	.....	D12/209
D523,384 S	6/2006	Metros		
D525,578 S *	7/2006	Schell	.....	D12/211
D528,061 S	9/2006	Saridakis et al.		
D529,426 S	10/2006	Metros		
D534,113 S	12/2006	Metros		
D540,239 S *	4/2007	Pfeiffer	.....	D12/211
D540,732 S	4/2007	Metros		

D544,426 S	6/2007	Siler		
D566,641 S	4/2008	Fuligni		
D567,165 S *	4/2008	Truebsbach	.....	D12/209
D585,354 S *	1/2009	Powell et al.	.....	D12/211
D585,807 S *	2/2009	Scheu	.....	D12/211
D586,285 S *	2/2009	Fridie	.....	D12/211

**OTHER PUBLICATIONS**

OEM Rims Factory Wheels Stock Rim Chrome Replica Wheel Used Rims Wheels O . . . <http://www.finishlinewheels.com/specials/11,FORD%2BTRUCK/>.

<http://www.pickuptruck.com/html/news/ford/raptor/page12008.html>.

Detroit Wheel and Tire: Product Search <http://www.detroitwheelandtire.com/search/?make=149&year=2008&model=675>.

2005 Chicago Auto Show, Ford, F150 Harley Davidson.  
2008 Detroit Auto Show, Ford, F150 Platinum.

\* cited by examiner

*Primary Examiner*—Elizabeth A Albert

*Assistant Examiner*—Kelley A Donnelly

(74) *Attorney, Agent, or Firm*—Damian Porcari

(57)

**CLAIM**

An ornamental design for a vehicle wheel, as shown and described.

**DESCRIPTION**

FIG. 1 is a front view of a vehicle wheel; and,

FIG. 2 is a perspective view of the vehicle wheel.

The broken lines in the drawings are for environmental purposes only and form no part of the claimed design.

**1 Claim, 2 Drawing Sheets**

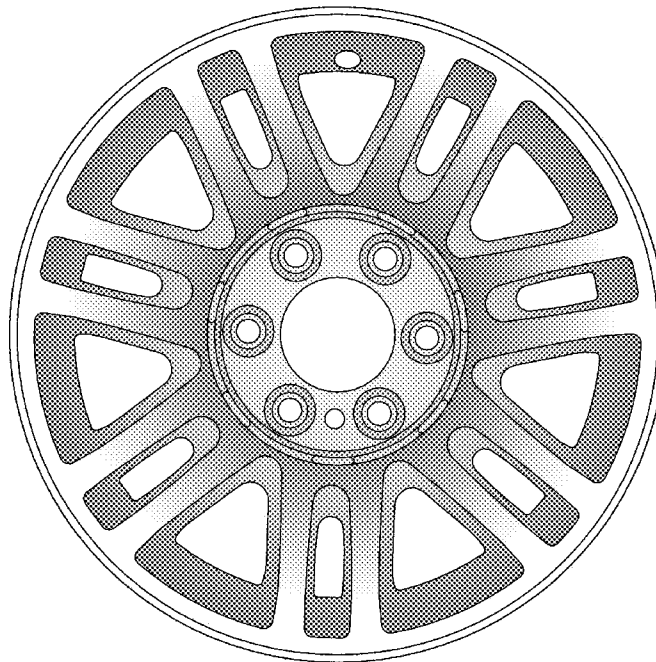

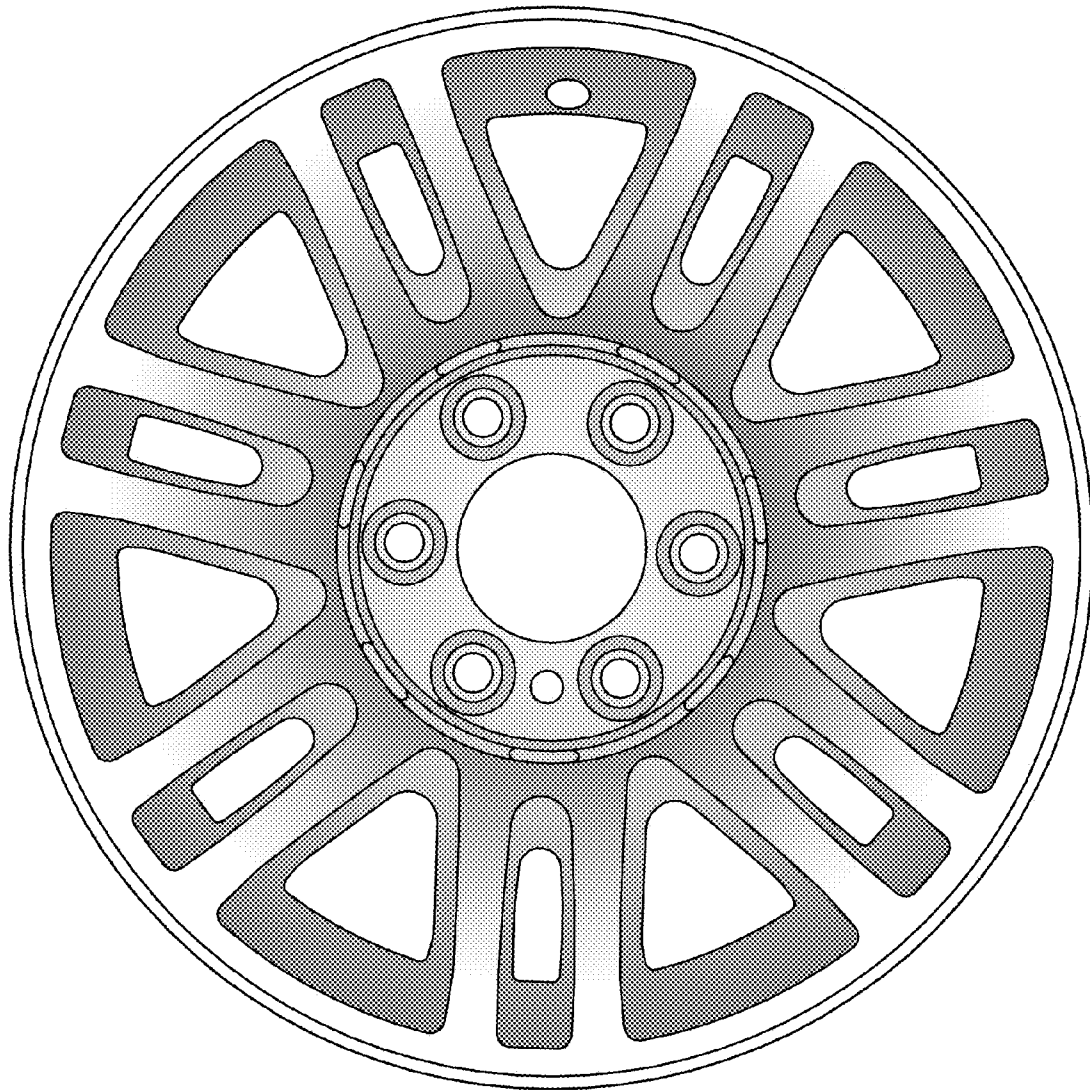

*Figure 1*

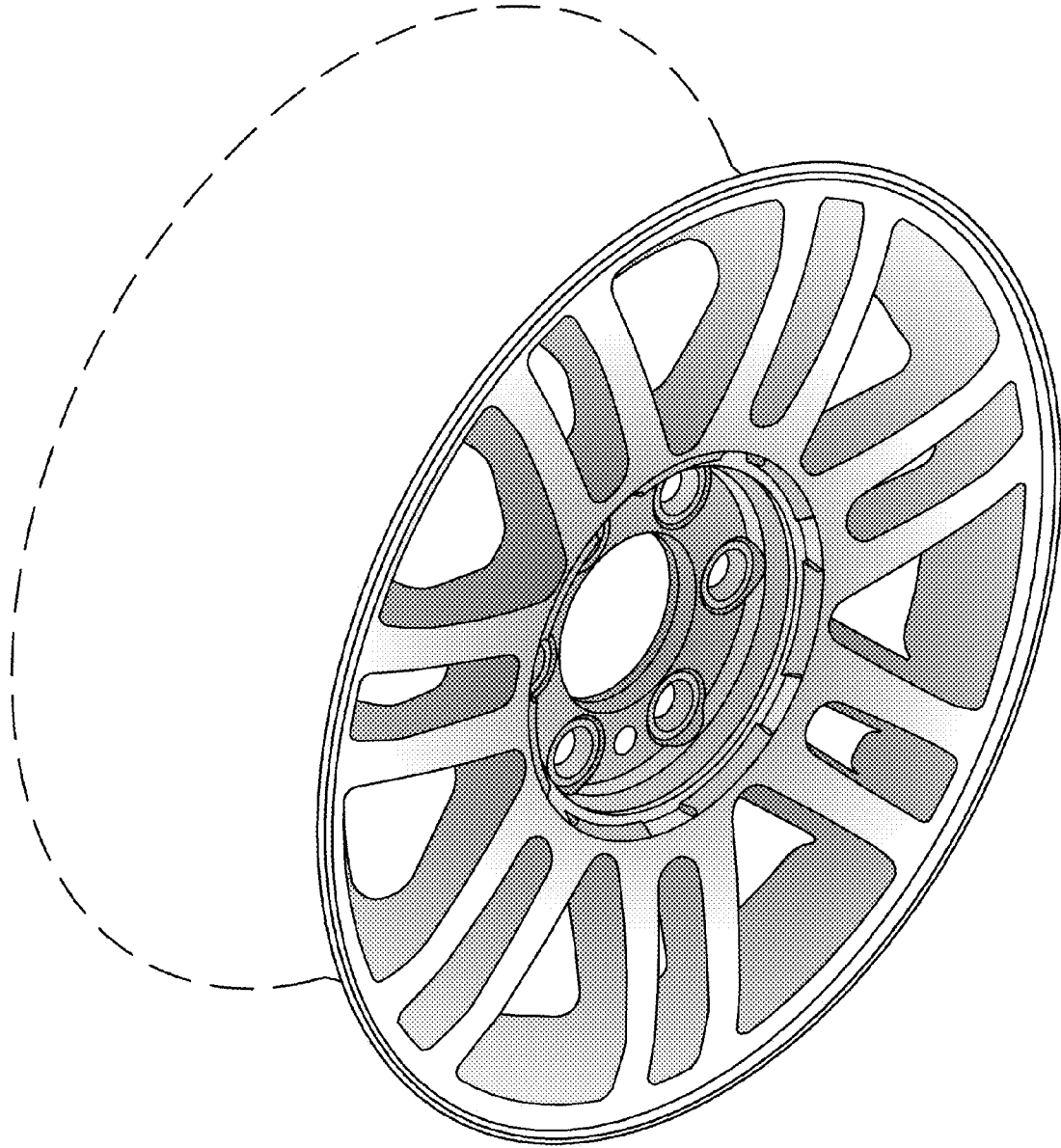

*Figure 2*