

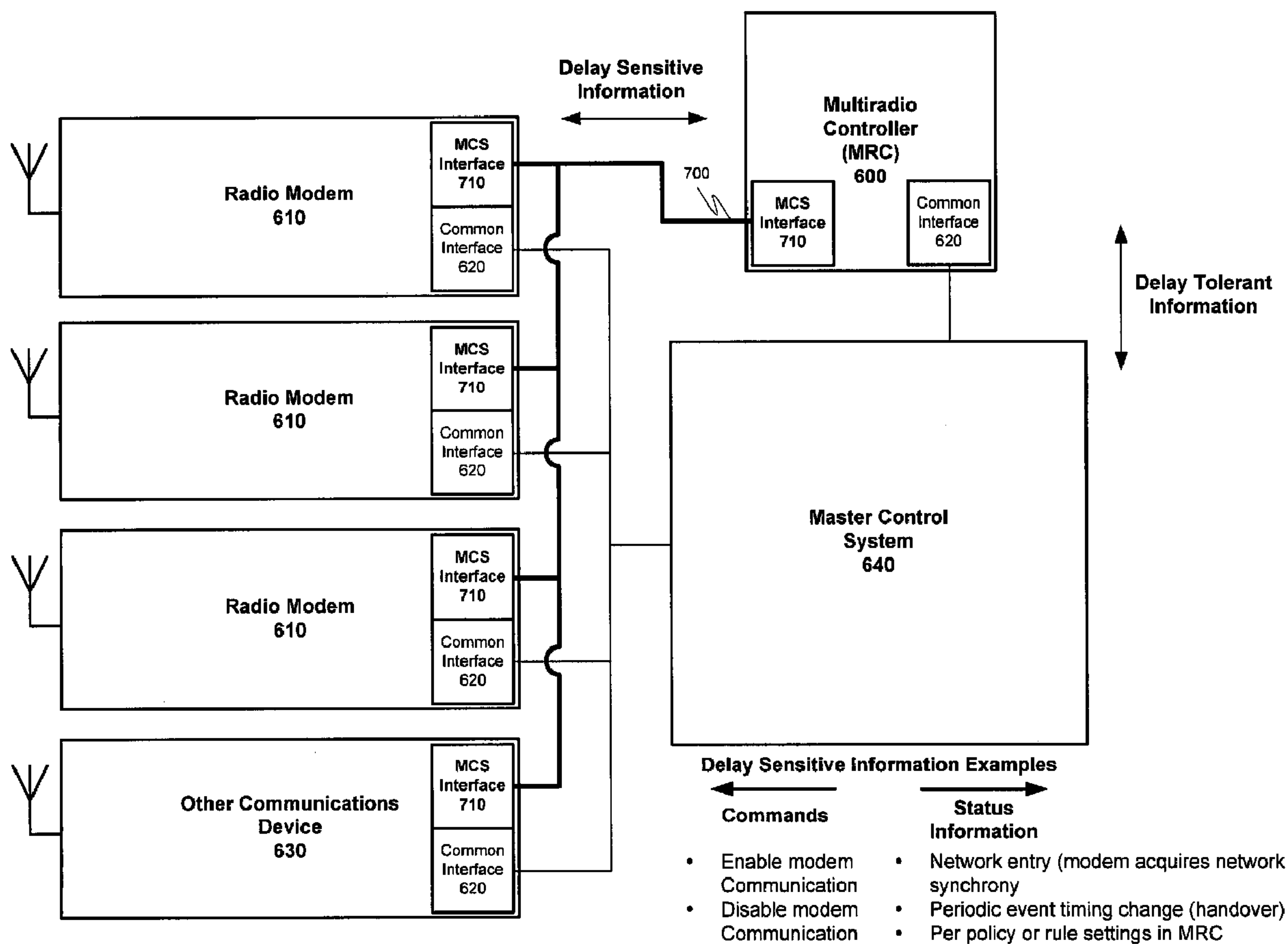

(86) Date de dépôt PCT/PCT Filing Date: 2007/05/08
 (87) Date publication PCT/PCT Publication Date: 2007/11/22
 (85) Entrée phase nationale/National Entry: 2008/09/08
 (86) N° demande PCT/PCT Application No.: IB 2007/001193
 (87) N° publication PCT/PCT Publication No.: 2007/132317
 (30) Priorité/Priority: 2006/05/11 (US11/431,706)

(51) Cl.Int./Int.Cl. *H04W 56/00* (2009.01),
H04W 36/00 (2009.01), *H04W 88/12* (2009.01)
 (71) Demandeur/Applicant:
NOKIA CORPORATION, FI
 (72) Inventeurs/Inventors:
KASSLIN, MIKA, FI;
KIUKKONEN, NIKO, FI;
PALIN, ARTO, FI;
WIJTING, CARL, FI
 (74) Agent: SIM & MCBURNEY

(54) Titre : ELEMENT DE CONTROLEUR MULTIRADIO DANS UN MODEM
 (54) Title: MULTIRADIO CONTROL INTERFACE ELEMENT IN MODEM



(57) Abrégé/Abstract:

A system for managing the simultaneous operation of a plurality of radio modems in a single wireless communication device (WCD). The multiradio control may be integrated into the WCD as a subsystem responsible for scheduling wireless

(57) **Abrégé(suite)/Abstract(continued):**

communications by temporarily enabling or disabling the plurality of radio modems within the device. The multiradio control system may comprise a multiradio controller (MRC) and a plurality dedicated radio interfaces. The radio interfaces are dedicated to quickly conveying delay sensitive information to and from the radio modems. This information may be requested by the MRC, or provided by one or more of the plurality of radio modems, if a change occurs during operation.

(12) INTERNATIONAL APPLICATION PUBLISHED UNDER THE PATENT COOPERATION TREATY (PCT)

(19) World Intellectual Property Organization
International Bureau(43) International Publication Date
22 November 2007 (22.11.2007)

PCT

(10) International Publication Number
WO 2007/132317 A3

(51) International Patent Classification:

H04Q 7/32 (2006.01) *H04L* 12/56 (2006.01)
H04B 1/40 (2006.01)

(21) International Application Number:

PCT/IB2007/001193

(22) International Filing Date: 8 May 2007 (08.05.2007)

(25) Filing Language: English

(26) Publication Language: English

(30) Priority Data:

11/431,706 11 May 2006 (11.05.2006) US

(71) Applicant (for all designated States except US): **NOKIA CORPORATION** [FI/FI]; Keilalahdentie 4, FIN-02150 Espoo (FI).(71) Applicant (for LC only): **NOKIA INC.** [US/US]; 6000 Connection Drive, Irving, Texas 75039 (US).

(72) Inventors; and

(75) Inventors/Applicants (for US only): **KASSLIN, Mika** [FI/FI]; Seljamäki 6 A, FIN-02770 Espoo (FI). **KIUKKONEN, Niko** [FI/FI]; Käärmekuusenpolku 4 F 23, FIN-02880 Veikkola (FI). **PALIN, Arto** [FI/FI]; Rantatie 39, FIN-37830 Viiala (FI). **WIJTING, Carl** [NL/FI]; Kuusitie 7A 12, FIN-00270 Helsinki (FI).(74) Agent: **FRANK, Elliot, L.**; c/o MORGAN & FINNEGAN LLP, Three World Financial Center, New York, New York 10281-2101 (US).

(81) Designated States (unless otherwise indicated, for every kind of national protection available): AE, AG, AL, AM, AT, AU, AZ, BA, BB, BG, BH, BR, BW, BY, BZ, CA, CH, CN, CO, CR, CU, CZ, DE, DK, DM, DZ, EC, EE, EG, ES, FI, GB, GD, GE, GH, GM, GT, HN, HR, HU, ID, IL, IN, IS, JP, KE, KG, KM, KN, KP, KR, KZ, LA, LC, LK, LR, LS, LT, LU, LY, MA, MD, MG, MK, MN, MW, MX, MY, MZ, NA, NG, NI, NO, NZ, OM, PG, PH, PL, PT, RO, RS, RU, SC, SD, SE, SG, SK, SL, SM, SV, SY, TJ, TM, TN, TR, TT, TZ, UA, UG, US, UZ, VC, VN, ZA, ZM, ZW.

(84) Designated States (unless otherwise indicated, for every kind of regional protection available): ARIPO (BW, GH, GM, KE, LS, MW, MZ, NA, SD, SL, SZ, TZ, UG, ZM, ZW), Eurasian (AM, AZ, BY, KG, KZ, MD, RU, TJ, TM), European (AT, BE, BG, CH, CY, CZ, DE, DK, EE, ES, FI, FR, GB, GR, HU, IE, IS, IT, LT, LU, LV, MC, MT, NL, PL, PT, RO, SE, SI, SK, TR), OAPI (BF, BJ, CF, CG, CI, CM, GA, GN, GQ, GW, ML, MR, NE, SN, TD, TG).

Published:

— with international search report

(88) Date of publication of the international search report:

10 April 2008

(54) Title: MULTIRADIO CONTROL INTERFACE ELEMENT IN MODEM

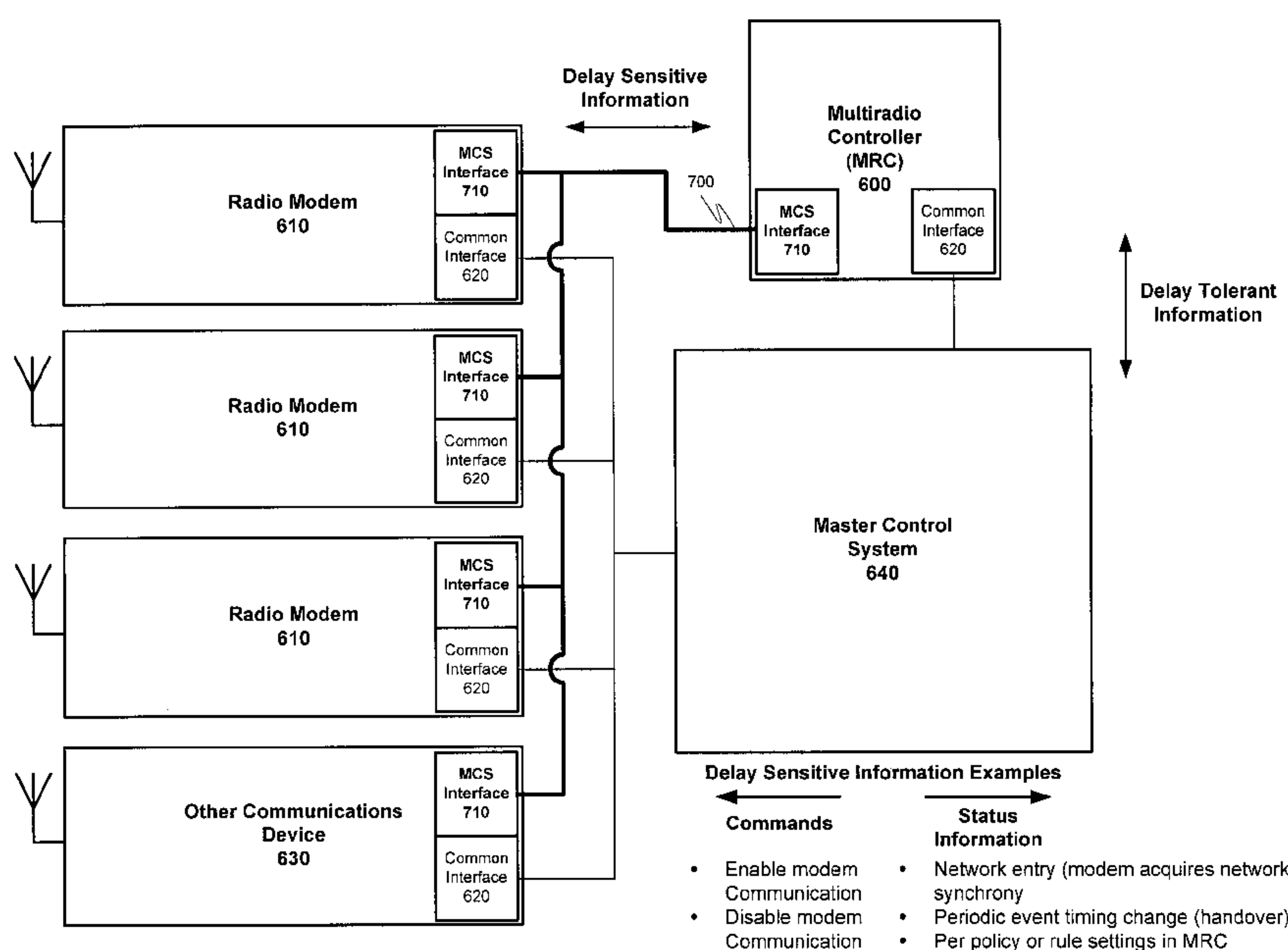

(57) Abstract: A system for managing the simultaneous operation of a plurality of radio modems in a single wireless communication device (WCD). The multiradio control may be integrated into the WCD as a subsystem responsible for scheduling wireless communications by temporarily enabling or disabling the plurality of radio modems within the device. The multiradio control system may comprise a multiradio controller (MRC) and a plurality dedicated radio interfaces. The radio interfaces are dedicated to quickly conveying delay sensitive information to and from the radio modems. This information may be requested by the MRC, or provided by one or more of the plurality of radio modems, if a change occurs during operation.

WO 2007/132317 A3

MULTIRADIO CONTROL INTERFACE ELEMENT IN MODEM**RELATED CASES**

[0001] This international application claims priority to U.S. Application Serial No. 11/431,706, filed May 11, 2006, entitled "MULTIRADIO CONTROL INTERFACE ELEMENT IN MODEM", which is incorporated herein by reference in its entirety.

BACKGROUND OF THE INVENTION

[0002] The present invention relates to a system for managing multiple radio modems imbedded in a wireless communication device, and more specifically to a multiradio control system for scheduling a plurality of active radio modems so as to avoid communication conflicts.

2. Description of Prior Art:

[0003] Modern society has quickly adopted, and become reliant upon, handheld devices for wireless communication. For example, cellular telephones continue to proliferate in the global marketplace due to technological improvements in both the quality of the communication and the functionality of the devices. These wireless communication devices (WCDs) have become commonplace for both personal and business use, allowing users to transmit and receive voice, text and graphical data from a multitude of geographic locations. The communication networks utilized by these devices span different frequencies and cover different transmission distances, each having strengths desirable for various applications.

[0004] Cellular networks facilitate WCD communication over large geographic areas. These network technologies have commonly been divided by generations, starting in the late 1970s to early 1980s with first generation (1G) analog cellular telephones that provided baseline voice communications, to modern digital cellular telephones. GSM is an example of a widely employed 2G digital cellular network communicating in the 900 MHz/1.8 GHz bands in Europe and at 850 MHz and 1.9 GHz in the United States. This network provides voice communication and also supports the transmission of textual data via the Short Messaging Service (SMS).

SMS allows a WCD to transmit and receive text messages of up to 160 characters, while providing data transfer to packet networks, ISDN and POTS users at 9.6 Kbps. The Multimedia Messaging Service (MMS), an enhanced messaging system allowing for the transmission of sound, graphics and video files in addition to simple text, has also become available in certain devices. Soon emerging technologies such as Digital Video Broadcasting for Handheld Devices (DVB-H) will make streaming digital video, and other similar content, available via direct transmission to a WCD. While long-range communication networks like GSM are a well-accepted means for transmitting and receiving data, due to cost, traffic and legislative concerns, these networks may not be appropriate for all data applications.

[0005] Short-range wireless networks provide communication solutions that avoid some of the problems seen in large cellular networks. Bluetooth™ is an example of a short-range wireless technology quickly gaining acceptance in the marketplace. A Bluetooth™ enabled WCD transmits and receives data at a rate of 720 Kbps within a range of 10 meters, and may transmit up to 100 meters with additional power boosting. A user does not actively instigate a Bluetooth™ network. Instead, a plurality of devices within operating range of each other will automatically form a network group called a “piconet”. Any device may promote itself to the master of the piconet, allowing it to control data exchanges with up to seven “active” slaves and 255 “parked” slaves. Active slaves exchange data based on the clock timing of the master. Parked slaves monitor a beacon signal in order to stay synchronized with the master, and wait for an active slot to become available. These devices continually switch between various active communication and power saving modes in order to transmit data to other piconet members. In addition to Bluetooth™ other popular short-range wireless networks include WLAN (of which “Wi-Fi” local access points communicating in accordance with the IEEE 802.11 standard, is an example), WUSB, UWB, ZigBee (802.15.4, 802.15.4a), and UHF RFID. All of these wireless mediums have features and advantages that make them appropriate for various applications.

[0006] More recently, manufacturers have also begun to incorporate various resources for providing enhanced functionality in WCDs (e.g., components and

software for performing close-proximity wireless information exchanges). Sensors and/or scanners may be used to read visual or electronic information into a device. A transaction may involve a user holding their WCD in proximity to a target, aiming their WCD at an object (e.g., to take a picture) or sweeping the device over a printed tag or document. Machine-readable technologies such as radio frequency identification (RFID), Infra-red (IR) communication, optical character recognition (OCR) and various other types of visual, electronic and magnetic scanning are used to quickly input desired information into the WCD without the need for manual entry by a user.

[0007] Device manufacturers are continuing to incorporate as many of the previously indicated exemplary communication features as possible into wireless communication devices in an attempt to bring powerful, “do-all” devices to market. Devices incorporating long-range, short-range and machine readable communication resources also often include multiple mediums for each category. This allows a communication device to flexibly adjust to its surroundings, for example, communicating both with a WLAN access point and a Bluetooth™ communication accessory, possibly at the same time.

[0008] Given the large array communications options compiled into one device, it is foreseeable that a user will want to employ a WCD to its full potential when replacing other productivity related devices. For example, a user may use a high powered WCD to replace other traditional, more cumbersome phones, computers, etc. In these situations, a WCD may be communicating simultaneously over numerous different wireless mediums. A user may use multiple peripheral Bluetooth™ devices (e.g., a headset and a keyboard) while having a voice conversation over GSM and interacting with a WLAN access point in order to access an Internet website. Problems may occur when these simultaneous communications cause interference with each other. Even if a communication medium does not have an identical operating frequency as another medium, a radio modem may cause extraneous interference to another medium. Further, it is also possible for the combined effects of two or more simultaneously operating radios to create intermodulation effects to another bandwidth due to harmonic effects. These

disturbances may cause errors resulting in the required retransmission of lost packets, and the overall degradation of performance for one or more communication mediums.

[0009] The utility of a communication device equipped with the ability to communicate over multiple wireless communication mediums is greatly hindered if these communications can only be employed one at a time. Therefore, what is needed is a system to manage these various communication mediums so that they can function simultaneously with a negligible impact in performance. The system should be able to identify and understand the functionality of each wireless medium, and should be able to quickly react on changing conditions in the environment and control each medium so that interference is minimized.

SUMMARY OF INVENTION

[0010] The present invention includes a terminal, method, computer program, system and chipset for managing the simultaneous operation of a plurality of radio modems embedded in the same wireless communication device. The operations of these radio modems may be directly controlled by a multiradio control system also integrated into the same wireless device.

[0011] The multiradio control system (MCS) may include at least one multiradio controller (MRC). The MRC may communicate with each radio modem through either a communication interface common to the general control system of the WCD (common interface), or alternatively, it may utilize a specialized interface dedicated to transactions of the multiradio control system (MCS interface). While the common interface may be used to convey information between the MRC and the radio modems, it may suffer from communication delays due to ordinary traffic in the master control system (e.g., traffic from multiple running applications, user interactions, etc.). However, the MCS interfaces directly couple the MRC and communication resources of the WCD, and may allow the quick transmission of delay sensitive operational information and control commands regardless of master control system traffic. Delay sensitive information may be requested by the MRC, or may be

provided by one or more of the plurality of radio modems if a change occurs during operation.

[0012] The MRC may use both delay tolerant information received from the common interface system, and delay sensitive information received, in some cases, from the dedicated MCS interface system to control overall communications for the WCD. The MRC monitors active wireless communications to determine if a potential conflict exists. In order to avoid a conflict, the MRC may schedule modems by directly enabling or disabling them for time periods through commands issued to these radio modems. While any or all of these commands may be sent through the common interface system, the MCS interface system, which is dedicated only to conveying delay-sensitive information, may provide a direct route between the MRC and the radio modems that is immune from any communication overhead caused by other transactions in the master control system.

DESCRIPTION OF DRAWINGS

[0013] The invention will be further understood from the following detailed description of a preferred embodiment, taken in conjunction with appended drawings, in which:

[0014] FIG. 1 discloses an exemplary wireless operational environment, including wireless communication mediums of different effective range.

[0015] FIG. 2 discloses a modular description of an exemplary wireless communication device usable with at least one embodiment of the present invention.

[0016] FIG. 3 discloses an exemplary structural description of the wireless communication device previously described in FIG. 2.

[0017] FIG. 4 discloses an exemplary operational description of a wireless communication device utilizing a wireless communication medium in accordance with at least one embodiment of the present invention.

[0018] FIG. 5 discloses an operational example wherein interference occurs when utilizing multiple radio modems simultaneously within the same wireless communication device.

[0019] FIG. 6A discloses an exemplary structural description of a wireless communication device including a multiradio controller in accordance with at least one embodiment of the present invention.

[0020] FIG. 6B discloses a more detailed structural diagram of FIG. 6A including the multiradio controller and the radio modems.

[0021] FIG. 6C discloses an exemplary operational description of a wireless communication device including a multiradio controller in accordance with at least one embodiment of the present invention.

[0022] FIG. 7A discloses an exemplary structural description of a wireless communication device including a multiradio control system in accordance with at least one embodiment of the present invention.

[0023] FIG. 7B discloses a more detailed structural diagram of FIG. 7A including the multiradio control system and the radio modems.

[0024] FIG. 7C discloses an exemplary operational description of a wireless communication device including a multiradio control system in accordance with at least one embodiment of the present invention.

[0025] FIG. 8 discloses a more specific example of the functionality described in FIG. 7A-7C.

[0026] FIG. 9 discloses an exemplary information packet usable with at least one embodiment of the present invention.

[0027] FIG. 10 discloses exemplary timing diagrams for wireless radio modems usable with the present invention.

[0028] FIG. 11 discloses a flowchart explaining an exemplary process by which a multiradio controller receives information from a plurality of radio modems in accordance with at least one embodiment of the present invention.

[0029] FIG. 12 discloses a flowchart explaining an exemplary process by which a multiradio controller manages a plurality of radio modems when a potential conflict exists in accordance with at least one embodiment of the present invention.

DESCRIPTION OF PREFERRED EMBODIMENT

[0030] While the invention has been described in preferred embodiments, various changes can be made therein without departing from the spirit and scope of the invention, as described in the appended claims.

I. Wireless communication over different communication networks.

[0031] A WCD may both transmit and receive information over a wide array of wireless communication networks, each with different advantages regarding speed, range, quality (error correction), security (encoding), etc. These characteristics will dictate the amount of information that may be transferred to a receiving device, and the duration of the information transfer. FIG. 1 includes a diagram of a WCD and how it interacts with various types of wireless networks.

[0032] In the example pictured in FIG. 1, user 110 possesses WCD 100. This device may be anything from a basic cellular handset to a more complex device such as a wirelessly enabled palmtop or laptop computer. Near Field Communications (NFC) 130 include various transponder-type interactions wherein normally only the scanning device requires its own power source. WCD 100 scans source 120 via short-range communications. A transponder in source 120 may use the energy and/or clock signal contained within the scanning signal, as in the case of RFID communication, to respond with data stored in the transponder. These types of technologies usually have an effective transmission range on the order of ten feet, and may be able to deliver stored data in amounts from 96 bits to over a megabit (or 125 Kbytes) relatively quickly. These features make such technologies well suited for identification purposes, such as to receive an account number for a public transportation provider, a key code for an automatic electronic door lock, an account number for a credit or debit transaction, etc.

[0033] The transmission range between two devices may be extended if both devices are capable of performing powered communications. Short-range active

communications 140 includes applications wherein the sending and receiving devices are both active. An exemplary situation would include user 110 coming within effective transmission range of a BluetoothTM, WLAN, UWB, WUSB, etc. access point. The amount of information to be conveyed is unlimited, except that it must all be transferred in the time when user 110 is within effective transmission range of the access point. This duration is extremely limited if the user is, for example, strolling through a shopping mall or walking down a street. Due to the higher complexity of these wireless networks, additional time is also required to establish the initial connection to WCD 100, which may be increased if there are many devices queued for service in the area proximate to the access point. The effective transmission range of these networks depends on the technology, and may be from 32 ft. to over 300 ft.

[0034] Long-range networks 150 are used to provide virtually uninterrupted communication coverage for WCD 100. Land-based radio stations or satellites are used to relay various communications transactions worldwide. While these systems are extremely functional, the use of these systems are often charged on a per-minute basis to user 110, not including additional charges for data transfer (e.g., wireless Internet access). Further, the regulations covering these systems cause additional overhead for both the users and providers, making the use of these systems more cumbersome.

[0035] In view of the above, it becomes easy to understand the need for a variety of different communication resources combined into a single WCD. Since these types of devices are being used as replacements for a variety of conventional communications means, including land-land telephones, low-functionality cellular handsets, laptops enabled with wireless communications, etc., the devices must be able to easily adapt to a variety of different applications (e.g., voice communications, business programs, GPS, Internet communications, etc.) in a variety of different environments (e.g. office, automobile, outdoors, arenas, shops, etc.)

II. Wireless communication device

[0036] As previously described, the present invention may be implemented using a variety of wireless communication equipment. Therefore, it is important to

understand the communication tools available to user 110 before exploring the present invention. For example, in the case of a cellular telephone or other handheld wireless devices, the integrated data handling capabilities of the device play an important role in facilitating transactions between the transmitting and receiving devices.

[0037] FIG. 2 discloses an exemplary modular layout for a wireless communication device usable with the present invention. WCD 100 is broken down into modules representing the functional aspects of the device. These functions may be performed by the various combinations of software and/or hardware components discussed below.

[0038] Control module 210 regulates the operation of the device. Inputs may be received from various other modules included within WCD 100. For example, interference sensing module 220 may use various techniques known in the art to sense sources of environmental interference within the effective transmission range of the wireless communication device. Control module 210 interprets these data inputs, and in response, may issue control commands to the other modules in WCD 100.

[0039] Communications module 230 incorporates all of the communications aspects of WCD 100. As shown in FIG. 2, communications module 230 may include, for example, long-range communications module 232, short-range communications module 234 and machine-readable data module 236 (e.g., for NFC). Communications module 230 utilizes at least these sub-modules to receive a multitude of different types of communication from both local and long distance sources, and to transmit data to recipient devices within the transmission range of WCD 100.

Communications module 230 may be triggered by control module 210, or by control resources local to the module responding to sensed messages, environmental influences and/or other devices in proximity to WCD 100.

[0040] User interface module 240 includes visual, audible and tactile elements which allow the user 110 to receive data from, and enter data into, the device. The data entered by user 110 may be interpreted by control module 210 to affect the behavior of WCD 100. User-inputted data may also be transmitted by communications module 230 to other devices within effective transmission range. Other devices in transmission range may also send information to WCD 100 via

communications module 230, and control module 210 may cause this information to be transferred to user interface module 240 for presentment to the user.

[0041] Applications module 250 incorporates all other hardware and/or software applications on WCD 100. These applications may include sensors, interfaces, utilities, interpreters, data applications, etc., and may be invoked by control module 210 to read information provided by the various modules and in turn supply information to requesting modules in WCD 100.

[0042] FIG. 3 discloses an exemplary structural layout of WCD 100 according to an embodiment of the present invention that may be used to implement the functionality of the modular system previously described in FIG. 2. Processor 300 controls overall device operation. As shown in FIG. 3, processor 300 is coupled to communications sections 310, 312, 320 and 340. Processor 300 may be implemented with one or more microprocessors that are each capable of executing software instructions stored in memory 330.

[0043] Memory 330 may include random access memory (RAM), read only memory (ROM), and/or flash memory, and stores information in the form of data and software components (also referred to herein as modules). The data stored by memory 330 may be associated with particular software components. In addition, this data may be associated with databases, such as a bookmark database or a business database for scheduling, email, etc.

[0044] The software components stored by memory 330 include instructions that can be executed by processor 300. Various types of software components may be stored in memory 330. For instance, memory 330 may store software components that control the operation of communication sections 310, 312, 320 and 340. Memory 330 may also store software components including a firewall, a service guide manager, a bookmark database, user interface manager, and any communications utilities modules required to support WCD 100.

[0045] Long-range communications 310 performs functions related to the exchange of information over large geographic areas (such as cellular networks) via an antenna. These communication methods include technologies from the previously

described 1G to 3G. In addition to basic voice communications (e.g., via GSM), long-range communications 310 may operate to establish data communications sessions, such as General Packet Radio Service (GPRS) sessions and/or Universal Mobile Telecommunications System (UMTS) sessions. Also, long-range communications 310 may operate to transmit and receive messages, such as short messaging service (SMS) messages and/or multimedia messaging service (MMS) messages. As disclosed in FIG. 3, Long-range communications 310 may be composed of one or more subsystems supporting various long-range communications mediums. These subsystems may, for example, be radio modems enabled for various types of long-range wireless communication.

[0046] As a subset of long-range communications 310, or alternatively operating as an independent module separately connected to processor 300, broadcast receivers 312 allows WCD 100 to receive transmission messages via mediums such as Analog Radio, Digital Video Broadcast for Handheld Devices (DVB-H), Digital Audio Broadcasting (DAB), etc. These transmissions may be encoded so that only certain designated receiving devices may access the transmission content, and may contain text, audio or video information. In at least one example, WCD 100 may receive these transmissions and use information contained within the transmission signal to determine if the device is permitted to view the received content. As in the case of long-range communications 310, broadcast receivers 312 may be comprised of one or more radio modems utilized to receive a variety of broadcast information.

[0047] Short-range communications 320 is responsible for functions involving the exchange of information across short-range wireless networks. As described above and depicted in FIG. 3, examples of such short-range communications 320 are not limited to BluetoothTM, WLAN, UWB, Zigbee, UHF RFID, and Wireless USB connections. Accordingly, short-range communications 320 performs functions related to the establishment of short-range connections, as well as processing related to the transmission and reception of information via such connections. Short-range communications 320 may be composed of one or more subsystem made up of, for example, various radio modems employed to communicate via the previously indicated assortment of short range wireless mediums.

[0048] Short-range input device 340, also depicted in FIG. 3, may provide functionality related to the short-range scanning of machine-readable data (e.g., for NFC). For example, processor 300 may control short-range input device 340 to generate RF signals for activating an RFID transponder, and may in turn control the reception of signals from an RFID transponder. Other short-range scanning methods for reading machine-readable data that may be supported by the short-range input device 340 are not limited to IR communications, linear and 2-D (e.g., QR) bar code readers (including processes related to interpreting UPC labels), and optical character recognition devices for reading magnetic, UV, conductive or other types of coded data that may be provided in a tag using suitable ink. In order for the short-range input device 340 to scan the aforementioned types of machine-readable data, the input device may include a multitude of optical detectors, magnetic detectors, CCDs or other sensors known in the art for interpreting machine-readable information.

[0049] As further shown in FIG. 3, user interface 350 is also coupled to processor 300. User interface 350 facilitates the exchange of information with a user. FIG. 3 shows that user interface 350 includes a user input 360 and a user output 370. User input 360 may include one or more components that allow a user to input information. Examples of such components include keypads, touch screens, and microphones. User output 370 allows a user to receive information from the device. Thus, user output portion 370 may include various components, such as a display, light emitting diodes (LED), tactile emitters and one or more audio speakers. Exemplary displays include liquid crystal displays (LCDs), and other video displays.

[0050] WCD 100 may also include one or more transponders 380. This is essentially a passive device which may be programmed by processor 300 with information to be delivered in response to a scan from an outside source. For example, an RFID scanner mounted in a entryway may continuously emit radio frequency waves. When a person with a device containing transponder 380 walks through the door, the transponder is energized and may respond with information identifying the device, the person, etc.

[0051] Hardware corresponding to communications sections 310, 312, 320 and 340 provide for the transmission and reception of signals. Accordingly, these

portions may include components (e.g., electronics) that perform functions, such as modulation, demodulation, amplification, and filtering. These portions may be locally controlled, or controlled by processor 300 in accordance with software communications components stored in memory 330.

[0052] The elements shown in FIG. 3 may be constituted and coupled according to various techniques in order to produce the functionality described in FIG. 2. One such technique involves coupling separate hardware components corresponding to processor 300, communications sections 310, 312 and 320, memory 330, short-range input device 340, user interface 350, transponder 380, etc. through one or more bus interfaces. Alternatively, any and/or all of the individual components may be replaced by an integrated circuit in the form of a programmable logic device, gate array, ASIC, multi-chip module, etc. programmed to replicate the functions of the stand-alone devices. In addition, each of these components is coupled to a power source, such as a removable and/or rechargeable battery (not shown).

[0053] The user interface 350 may interact with a communications utilities software component, also contained in memory 330, which provides for the establishment of service sessions using long-range communications 310 and/or short-range communications 320. The communications utilities component may include various routines that allow the reception of services from remote devices according to mediums such as the Wireless Application Medium (WAP), Hypertext Markup Language (HTML) variants like Compact HTML (CHTML), etc.

III. Exemplary operation of a wireless communication device including potential interference problems encountered.

[0054] FIG. 4 discloses a stack approach to understanding the operation of a WCD. At the top level 400, user 110 interacts with WCD 100. The interaction involves user 110 entering information via user input 360 and receiving information from user output 370 in order to activate functionality in application level 410. In the application level, programs related to specific functionality within the device interact with both the user and the system level. These programs include applications for visual information (e.g., web browser, DVB-H receiver, etc.), audio information (e.g., cellular telephone, voice mail, conferencing software, DAB or analog radio receiver,

etc.), recording information (e.g., digital photography software, word processing, scheduling, etc.) or other information processing. Actions initiated at application level 410 may require information to be sent from or received into WCD 100. In the example of FIG. 4, data is requested to be sent to a recipient device via Bluetooth™ communication. As a result, application level 410 may then call resources in the system level to initiate the required processing and routing of data.

[0055] System level 420 processes data requests and routes the data for transmission. Processing may include, for example, calculation, translation, conversion and/or packetizing the data. The information may then be routed to an appropriate communication resource in the service level. If the desired communication resource is active and available in the service level 430, the packets may be routed to a radio modem for delivery via wireless transmission. There may be a plurality of modems operating using different wireless mediums. For example, in FIG. 4, modem 4 is activated and able to send packets using Bluetooth™ communication. However, a radio modem (as a hardware resource) need not be dedicated only to a specific wireless medium, and may be used for different types of communication depending on the requirements of the wireless medium and the hardware characteristics of the radio modem.

[0056] FIG. 5 discloses a situation wherein the above described exemplary operational process may cause more than one radio modem to become active. In this case, WCD 100 is both transmitting and receiving information via wireless communication over a multitude of mediums. WCD 100 may be interacting with various secondary devices such as those grouped at 500. For example, these devices may include cellular handsets communicating via long-range wireless communication like GSM, wireless headsets communicating via Bluetooth™, Internet access points communicating via WLAN, etc.

[0057] Problems may occur when some or all of these communications are carried on simultaneously. As further shown in FIG. 5, multiple modems operating simultaneously may cause interference for each other. Such a situation may be encountered when WCD 100 is communicating with more than one external device (as previously described). In an exemplary extreme case, devices with modems

simultaneously communicating via Bluetooth™, WLAN and wireless USB would encounter substantial overlap since all of these wireless mediums operate in the 2.4 GHz band. The interference, shown as an overlapping portion of the fields depicted in FIG. 5, would cause packets to be lost and the need for retransmission of these lost packets. Retransmission requires that future time slots be used to retransmit lost information, and therefore, overall communications performance will at least be reduced, if the signal is not lost completely. The present invention, in at least one embodiment, seeks to manage such situations where communications are occurring simultaneously so that anticipated interference is minimized or totally avoided, and as a result, both speed and quality are maximized.

IV. A wireless communication device including a multiradio controller.

[0058] In an attempt to better manage communications in WCD 100, an additional controller dedicated to managing wireless communications may be introduced. WCD 100, as pictured in FIG. 6A, includes a multiradio controller (MRC) 600. MRC 600 is coupled to the master control system of WCD 100. This coupling enables MRC 600 to communicate with radio modems or other similar devices in communications modules 310 312, 320 and 340 via the master operating system of WCD 100. While this configuration may in some cases improve overall wireless communications efficiency for WCD 100, problems may occur when WCD 100 becomes busy (e.g., when the control system of WCD 100 is employed in multitasking many different simultaneous operations, both communications and non-communications related).

[0059] FIG. 6B discloses in detail at least one embodiment of WCD 100, which may include multiradio controller (MRC) 600 introduced in FIG. 6A. MRC 600 includes common interface 620 by which information may be sent or received through master control system 640. Further, each radio modem 610 or similar communication device 630, for example an RFID scanner for scanning machine-readable information, may also include some sort of common interface 620 for communicating with master control system 640. As a result, all information, commands, etc. occurring between radio modems 610, similar devices 630 and MRC 600 are conveyed by the communications resources of master control system 640.

The possible effect of sharing communications resources with all the other functional modules within WCD 100 will be discussed with respect to FIG. 6C.

[0060] FIG. 6C discloses an operational diagram similar to FIG. 4 including the effect of MRC 600. In this system MRC 600 may receive operational data from the master operating system of WCD 100, concerning for example applications running in application level 410, and status data from the various radio communication devices in service level 430. MRC 600 may use this information to issue scheduling commands to the communication devices in service level 430 in an attempt to avoid communication problems. However, problems may occur when the operations of WCD 100 are fully employed. Since the various applications in application level 410, the operating system in system level 420, the communications devices in service level 430 and MRC 600 must all share the same communications system, delays may occur when all aspects of WCD 100 are trying to communicate on the common interface system 620. As a result, delay sensitive information regarding both communication resource status information and radio modem 610 control information may become delayed, nullifying any beneficial effect from MRC 600. Therefore, a system better able to handle the differentiation and routing of delay sensitive information is required if the beneficial effect of MRC 600 is to be realized.

V. A wireless communication device including a multiradio control system.

[0061] FIG. 7A introduces MRC 600 as part of a multiradio control system (MCS) 700 in WCD 100. MCS 700 directly links the communications resources of modules 310, 312, 320 and 340 to MRC 600. MCS 700 may provide a dedicated low-traffic communication structure for carrying delay sensitive information both to and from MRC 600.

[0062] Additional detail is shown in FIG. 7B. MCS 700 forms a direct link between MRC 600 and the communication resources of WCD 100. This link may be established by a system of dedicated MCS interfaces 710 and 720. For example, MCS interface 720 may be coupled to MRC 600. MCS Interfaces 710 may connect radio modems 610 and other similar communications devices 630 to MCS 700 in order to form an information conveyance for allowing delay sensitive information to travel to and from MRC 600. In this way, the abilities of MRC 600 are no longer

influenced by the processing load of master control system 640. As a result, any information still communicated by master control system 640 to and from MRC 600 may be deemed delay tolerant, and therefore, the actual arrival time of this information does not substantially influence system performance. On the other hand, all delay sensitive information is directed to MCS 700, and therefore is insulated from the loading of the master control system.

[0063] The effect of MCS 700 is seen in FIG. 7C. Information may now be received in MRC 600 from at least two sources. System level 420 may continue to provide information to MRC 600 through master control system 640. In addition, service level 430 may specifically provide delay sensitive information conveyed by MCS 700. MRC 600 may distinguish between these two classes of information and act accordingly. Delay tolerant information may include information that typically does not change when a radio modem is actively engaged in communication, such as radio mode information (e.g., GPRS, BluetoothTM, WLAN, etc.), priority information that may be defined by user settings, the specific service the radio is driving (QoS, real time/non real time), etc. Since delay tolerant information changes infrequently, it may be delivered in due course by master control system 640 of WCD 100. Alternatively, delay sensitive (or time sensitive) information includes at least modem operational information that frequently changes during the course of a wireless connection, and therefore, requires immediate update. As a result, delay sensitive information may need to be delivered directly from the plurality of radio modems 610 through the MCS interfaces 710 and 720 to MRC 600, and may include radio modem synchronization information. Delay sensitive information may be provided in response to a request by MRC 600, or may be delivered as a result of a change in radio modem settings during transmission, such as due to wireless handover or handoff.

[0064] As a part of information acquisition services, the MCS interface 710 needs to send information to MRC 600 about periodic events of the radio modems 610. Using its MCS interface 710, the radio modem 610 may indicate a time instance of a periodic event related to its operation. In practice these instances are times when radio modem 610 is active and may be preparing to communicate or communicating.

Events occurring prior to or during a transmission or reception mode may be used as a time reference (e.g., in case of GSM, the frame edge may be indicated in a modem that is not necessarily transmitting or receiving at that moment, but we know based on the frame clock that the modem is going to transmit [x]ms after the frame clock edge). Basic principle for such timing indications is that the event is periodic in nature. Every incident needs not to be indicated, but the MRC 600 may calculate intermediate incidents itself. In order for that to be possible, MRC 600 would also require other relevant information about the event, e.g. periodicity and duration. This information may be either embedded in the indication or MRC 600 may get it by other means. Most importantly, however, these timing indications need to be such that the MRC 600 can acquire a radio modem's basic periodicity and timing. The timing of the event may either be in the indication itself, or it may be implicitly defined from the indication information by MRC 600.

[0065] In general terms these timing indications need to be provided on periodic events like: schedule broadcasts from a base station (typically TDMA/MAC frame boundaries) and own periodic transmission or reception periods (typically Tx/Rx slots). Those notifications need to be issued by the radio modem 610: (1) on network entry (i.e. modem acquires network synchrony), (2) on periodic event timing change e.g. due to a handover and (3) as per the policy and configuration settings from MRC 600.

[0066] FIG. 8 discloses a more specific example of the interaction between MRC 600, MCS 700 and a radio modem 610. MRC 600 requires a bi-directional multipoint control interface for each radio under control. In this example, MCS 700 may be used to (1) Get synchronization information from the radio modem 610 to MRC 600, and (2) Provide radio activity control signals from MRC 600 to the radio modem 610 (enable/disable transmission and/or reception). In addition, as previously stated, MCS 700 may be used to communicate radio parameters that are delay sensitive from a controlling point of view between MRC 600 and the radio modem 610. One example of parameters that may be communicated over MCS 700 is the packet type based priority information from MRC 600 to radio modem 610. The packet type based priority information can be used, for example, to allow a WLAN

modem to transmit acknowledgement type packets even though the radio activity control signal is not allowing the transmission. This packet type based priority information is typically communicated less frequently than the radio activity control signals. MCS interface 710 can be shared between different radio modems (multipoint) but it cannot be shared with any other functionality that could limit the usage of MCS interface 710 from latency point of view.

[0067] MCS 700 is used primarily to communicate the enabled/disabled radio activity periods from MRC 600 to the radio modem 610 and in turn get synchronization indications from the radio modems back to MRC 600. The control signals from MRC 600 that enable/disable a radio modem 610 should be built on a modem's periodic events. MRC 600 gets this information about a radio modem's periodic events from synchronization indications issued by the radio modem 610. This kind of event can be, for example, frame clock event in GSM (4.615 ms), slot clock event in BT (625 us) or any multiple of these. A radio modem 610 may send its synchronization indications when (1) MRC requests it, (2) a radio modem internal time reference is changed (e.g. due to handover or handoff). The latency requirement for the synchronization signal is not critical as long as the delay is constant within a few microseconds. The fixed delays can be taken into account in MRC 600 scheduling logic.

[0068] The radio modem activity control is based on the knowledge of when the active radio modems 610 are about to transmit (or receive) in the specific connection mode in which the radio modems 610 are currently operating. The connection mode of a radio modem 610 is mapped to the time domain operation in MRC 600. As an example, for a GSM speech connection, MRC 600 has knowledge about all traffic patterns of GSM. This means that MRC 600 recognizes that the speech connection in GSM includes one transmission slot of length 577 μ s, followed by an empty slot after which is the reception slot of 577 μ s, two empty slots, monitoring (RX on), two empty slots, and then it repeats. Dual transfer mode means two transmission slots, empty slot, reception slot, empty slot, monitoring and two empty slots. When all traffic patterns that are known a priori by the MRC 600, it only needs to know when the transmission slot occurs in time to gain knowledge of when

GSM radio is active. This information may be obtained with the radio synchronization signal. When the active radio modem 610 is about to transmit (or receive) it must check every time whether the modem activity control signal from MRC 600 permits the communication. MRC 600 is always either allowing or disabling the transmission of one full radio transmission block (e.g. GSM slot).

[0069] An example message packet 900 is disclosed in FIG. 9. Example message packet 900 includes activity pattern information that may be provided by MRC 600 to radio modems 610. The data payload of packet 900 may include at least Message ID information, allowed/disallowed transmission (Tx) period information, allowed/disallowed reception (Rx) period information, Tx/Rx periodicity (how often the Tx/Rx activities contained in the period information occur), and validity information describing when the activity pattern becomes valid and whether the new activity pattern is replacing or added to the existing one. The data payload of packet 900, as shown, may consist of multiple allowed/disallowed periods for transmission or reception (e.g., Tx period 1, 2...) each containing at least a period start time and a period end time during which radio modem 610 may either be permitted or prevented from executing a communication activity. The ability to include multiple allowed/disallowed periods into a single message packet 900 may support MRC 600 in scheduling radio modem behavior for longer periods of time, which may result in a reduction in message traffic. Further, changes in radio modem 610 activity patterns may be amended using the validity information in each message packet 900.

[0070] The modem activity control signal (e.g., packet 900) is transmitted by MRC 600 to a specific radio modem 610. The signal may include activity periods for Tx and Rx separately, and the periodicity of the activity for the radio modem 610. While the native radio modem clock is the controlling time domain (never overwritten), the time reference utilized in synchronizing the activity periods to current radio modem operation may be based one of at least two standards. In a first example, a transmission period may start after a pre-defined amount of synchronization events have occurred in radio modem 610. Alternatively, all timing between radio modem 610 and MRC 600 may be standardized around the system clock for MCS 700. Advantages and disadvantages exist for both solutions. Using a

defined number of modem synchronization events is beneficial because then all timing is closely aligned with the radio modem clock. However, this strategy may be more complicated to implement than basing timing on the system clock. On the other hand, while timing based on the system clock may be easier to implement as a time standard, a conversion to modem clock timing must necessarily be implemented whenever a new activity pattern is put into use in radio modem 610.

[0071] As stated above, the activity period may be indicated as start and stop times. If there is only one active connection, or if there is no need to schedule the active connections, the modem activity control signal may be set always on allowing the radio modems to operate without restriction. The modem should check whether the transmission or reception is allowed before attempting the actual communication. A resynchronization may be initiated by the radio modem 610 if the transmission is consecutively blocked. The same happens if a radio modem time reference or connection mode changes. A problem may occur if MRC 600 runs out of the modem synchronization and starts to apply modem transmission/reception restrictions at the wrong time. Due to this, modem synchronization signals need to be updated periodically. The more wireless connections that are active, the more accurate MRC synchronization information needs to be.

[0072] FIG. 10 discloses a pictorial example of timing patterns between various active radio modems. Modems 1, 2 and 3 all have individual patterns that indicate when a modem is actively transmitting and/or receiving information. One example of a period wherein a possible conflict exists is highlighted in the figure. At this point MRC 600 may act to control various radio modems 610 in order to avoid the conflict. If the activity is to be restricted, MRC 600 configures the modem activity control message so that activity is always denied when radio modem 610 is not allowed to transmit or receive. The restriction can last either the whole period or just an individual transmission/reception instance. In the latter case, the activity can be allowed for some other transactional instance inside the period and radio modem 610 can utilize this to transmit (e.g. to attempt retransmission).

[0073] Radio modem 610 can indicate to MRC 600 the radio activity periods that were blocked due to the modem activity control message. This additional

communication can be as a safety procedure to ensure that MRC 600 is not continuously blocking the communications due to off synchronization conditions. Radio modem 610 can switch off the transmitter/receiver every time the modem activity control signal is not allowing communication. Because the modem activity control signal is transmitted in advance and it provides information about the allowed and disallowed radio transmission/reception instances in the near future, radio modem 610 can prepare its operations in advance according to the activity control signal. Inside the validity parameter in the activity control message is a field describing whether the new message is replacing or added to the existing activity periods, thus avoiding the need to communicate the full transmission/reception pattern if only minor modifications are needed to correct the operation of the transmitter/receiver.

[0074] A flowchart describing an exemplary process where MRC 600 requests synchronization information from a radio modem in accordance with at least one embodiment of the present invention is disclosed in FIG. 11. In step 1102, the application layer of WCD 100 triggers activation of a communication service. This activation may occur, for instance, due to a manual intervention by user 110 directly activating the communication service, or may instead be triggered indirectly by an application currently being manipulated by user 110. WCD 100 may then activate the service in step 1104. Various subsystems of WCD 100 are notified of the service activation, including MRC 600 (step 1106) which in turn requests clock synchronization information from radio modem 610 via MCS 700 in step 1108. The synchronization request remains active until MRC 600 has received the signal and is synchronized (step 1110). In step 1112, MRC 600 monitors for other radio modem activations, wherein a synchronization signal would need to be requested, or for changes in existing modem behavior. A detected change in radio modem behavior, for example during a handover or handoff, would be detected due to radio modem 610 itself prompting the delivery of synchronization information in step 1114, and so new synchronization information is delivered to MRC 600.

[0075] FIG. 12 includes an example of a process wherein MRC 600 monitors active radio modems and implements scheduling in order to avoid conflicts. In step 1202, MRC 600 monitors a plurality of active radio modems. During this monitoring,

MRC 700 may further recognize that at least some of the plurality of modems are about to act simultaneously which may result in a potential conflict (steps 1204 and 1206). MRC 600, which has hierarchical information about the various mediums serviced by the radio modems, may then prioritize the radio modems in order to determine which modems to disable (step 1208). In step 1210, MRC 600 transmits disable commands to various modems, essentially pausing the activity of these modems over designated time periods in order to avoid potential conflicts. The optimal timeframe where the decisions of whether radio modem 610 is allowed to transmit or not, needs to be selected to meet the following three criteria: (1) Constant (up to some limits) delay from the control point to the air interface, (2) It must be possible to affect the transmission of individual packets/slots (whatever is the smallest granularity in air interface), (3) Preferably it should be possible to buffer a few transmission packets to a memory in case the transmission is not instantly allowed. The need to buffer packets depends also on the service the radio modem 610 is running. In case of a real time service, the buffering can be time sensitive. Further, any disable information transmitted to radio modems 610 (step 1210) may also be transmitted to the master control system in step 1212 in order to notify of temporary delays due to conflict avoidance, which might otherwise be deemed to be radio modem inoperability. Finally, in step 1214, MRC 600 reactivates all modems once the potential conflict has passed, and resumes monitoring for possible communication conflicts.

[0076] The present invention is an improvement over the state of the art. The multipoint control system of the present invention allows a device with a plurality of active radio modems to efficiently manage communications between these modems in order to avoid potential communication conflicts. This scheduling of wireless communication resources allows a wireless communication device to function in a fully enabled mode without experiencing communication quality degradation due to the constant retransmission of lost packets. The result is a fully enabled wireless communication device that satisfies user expectations because interactivity does not suffer as the device is fully deployed in more complex applications.

[0077] Accordingly, it will be apparent to persons skilled in the relevant art that various changes in form and detail can be made therein without departing from the spirit and scope of the invention. The breadth and scope of the present invention should not be limited by any of the above-described exemplary embodiments, but should be defined only in accordance with the following claims and their equivalents.

CLAIMS:

1. A method for controlling a plurality of radio modems, comprising:
 - transmitting synchronization information from a plurality of radio modems through interfaces to a multiradio controller, wherein each interface is coupled to at least a radio modem and is dedicated to conveying time-sensitive information;
 - utilizing the synchronization information in the multiradio controller to create an operational schedule for controlling the plurality of radio modems; and
 - transmitting control information from the multiradio controller through the interfaces to the plurality of radio modems.
2. The method of claim 1, wherein the plurality of radio modems, the interfaces and the multiradio controller are comprised within the same wireless communication device.
3. The method of claim 1, wherein the time-sensitive synchronization information is transmitted due to a change in at least one of the plurality of modems.
4. The method of claim 3, wherein the change is the result of at least one of a modem entering a wireless network and a modem experiencing handover or handoff.
5. The method of claim 1, wherein the time-sensitive synchronization information is transmitted per policy and configuration settings from the multiradio controller.
6. The method of claim 1, wherein the time-sensitive synchronization information is transmitted due to a request from the multiradio controller.
7. The method of claim 6, wherein the multiradio controller includes policies and/or rules dictating when to make the request for time-sensitive synchronization information from at least one of the plurality of radio modems.

8. The method of claim 1, wherein the operational schedule is created in order to avoid communication conflicts between the plurality of radio modems.
9. The method of claim 1, wherein the operational schedule is created based on the time-sensitive synchronization information and communication priority rules stored in the multiradio controller.
10. The method of claim 1, wherein the control information includes enable or disable commands that are checked by the plurality of radio modems prior to activating.
11. The method of claim 10, wherein the time at which the control information is checked by the plurality of radio modems is based on a constant delay between a control point and a radio modem antenna.
12. The method of claim 10, further comprising the plurality of radio modems buffering some radio packets prior to transmission to compensate for when the activation of at least one of the plurality of radio modems is disallowed.
13. The method of claim 1, wherein the control information controls the radio modems to the smallest message size granularity allowed by the particular radio modem.
14. A terminal device for controlling a plurality of radio modems, comprising:
 - a plurality of radio modems;
 - a multiradio controller; and
 - interfaces, coupled to the plurality radio modems and the multiradio controller, the interfaces being dedicated to conveying time-sensitive information;wherein the interfaces convey synchronization information from the plurality of radio modems to the multiradio controller, the multiradio controller

utilizing the synchronization information to create an operational schedule for controlling the plurality of radio modems; and

the interfaces further transmitting control information from the multiradio controller to the plurality of radio modems based on the operational schedule.

15. The terminal device of claim 14, wherein the multiradio controller includes policies and/or rules dictating when to request time-sensitive synchronization information from at least one of the plurality of radio modems.
16. The terminal device of claim 14, wherein the operational schedule is created based on the time-sensitive synchronization information and communication medium priority rules stored in the multiradio controller.
17. The terminal device of claim 14, wherein the control information includes enable or disable commands that are checked by the plurality of radio modems prior to activating.
18. The terminal device of claim 17, wherein the time at which the control information is checked by the plurality of radio modems is based on a constant delay between a control point and a radio modem antenna.
19. The terminal device of claim 17 wherein the plurality of radio modems further comprise a buffer for temporarily storing some radio packets prior to transmission to compensate for when the activation of at least one of the plurality of radio modems is disallowed.
20. The terminal device of claim 14, wherein the control information controls the radio modems to the smallest message size granularity allowed by the particular radio modem.
21. An interface for transmitting information between a plurality of radio modems and a multiradio controller, comprising:

a communication structure for transmitting time-sensitive synchronization information from a plurality of radio modems to a multiradio controller; and

a communication structure for transmitting time-sensitive control information from the multiradio controller to the plurality of radio modems.

22. The interface of claim 21, wherein the interfaces are combined within each radio modem to form a single device.
23. The interface of claim 21, wherein the interfaces are stand-alone devices coupled to each radio modem.
24. The interface of claim 21, wherein the radio interface is enabled to distinguish time-sensitive synchronization information from other information provided by the plurality of radio modems.
25. A computer program product comprising a computer usable medium having computer readable program code embodied in said medium for controlling a plurality of radio modems, comprising:

a computer readable program code for transmitting synchronization information from a plurality of radio modems through interfaces to a multiradio controller, wherein each interface is coupled to at least a radio modem and is dedicated to conveying time-sensitive information;

a computer readable program code for utilizing the synchronization information in the multiradio controller to create an operational schedule for controlling the plurality of radio modems; and

a computer readable program code for transmitting control information from the multiradio controller through the interfaces to the plurality of radio modems.

26. The computer program product of claim 25, wherein the plurality of radio modems, the interfaces and the multiradio controller are comprised within the same wireless communication device.
27. The computer program product of claim 25, wherein the time-sensitive synchronization information is transmitted due to a change in at least one of the plurality of modems.
28. The computer program product of claim 27, wherein the change is the result of at least one of a modem entering a wireless network and a modem experiencing handover or handoff.
29. The computer program product of claim 25, wherein the time-sensitive synchronization information is transmitted per policy and configuration settings from the multiradio controller.
30. The computer program product of claim 25, wherein the time-sensitive synchronization information is transmitted due to a request from the multiradio controller.
31. The computer program product of claim 30, wherein the multiradio controller includes policies and/or rules dictating when to make the request for time-sensitive synchronization information from at least one of the plurality of radio modems.
32. The computer program product of claim 25, wherein the operational schedule is created in order to avoid communication conflicts between the plurality of radio modems.
33. The computer program product of claim 25, wherein the operational schedule is created based on the time-sensitive synchronization information and communication priority rules stored in the multiradio controller.

34. The computer program product of claim 25, wherein the control information includes enable or disable commands that are checked by the plurality of radio modems prior to activating.
35. The computer program product of claim 34, wherein the time at which the control information is checked by the plurality of radio modems is based on a constant delay between a control point and a radio modem antenna.
36. The computer program product of claim 34, further comprising the plurality of radio modems buffering some radio packets prior to transmission to compensate for when the activation of at least one of the plurality of radio modems is disallowed.
37. The computer program product of claim 25, wherein the control information controls the radio modems to the smallest message size granularity allowed by the particular radio modem.
38. A system for controlling a plurality of radio modems, comprising:
 - a plurality of radio modems;
 - a multiradio controller; and
 - interfaces, coupled to the plurality radio modems and the multiradio controller, the interfaces being dedicated to conveying time-sensitive information;wherein the interfaces transmit synchronization information from the plurality of radio modems to the multiradio controller, the multiradio controller utilizing the synchronization information to create an operational schedule for controlling the plurality of radio modems; and

the one or more radio interfaces further employed for transmitting control information from the multiradio controller to the plurality of radio modems based on the operational schedule.

FIG. 1

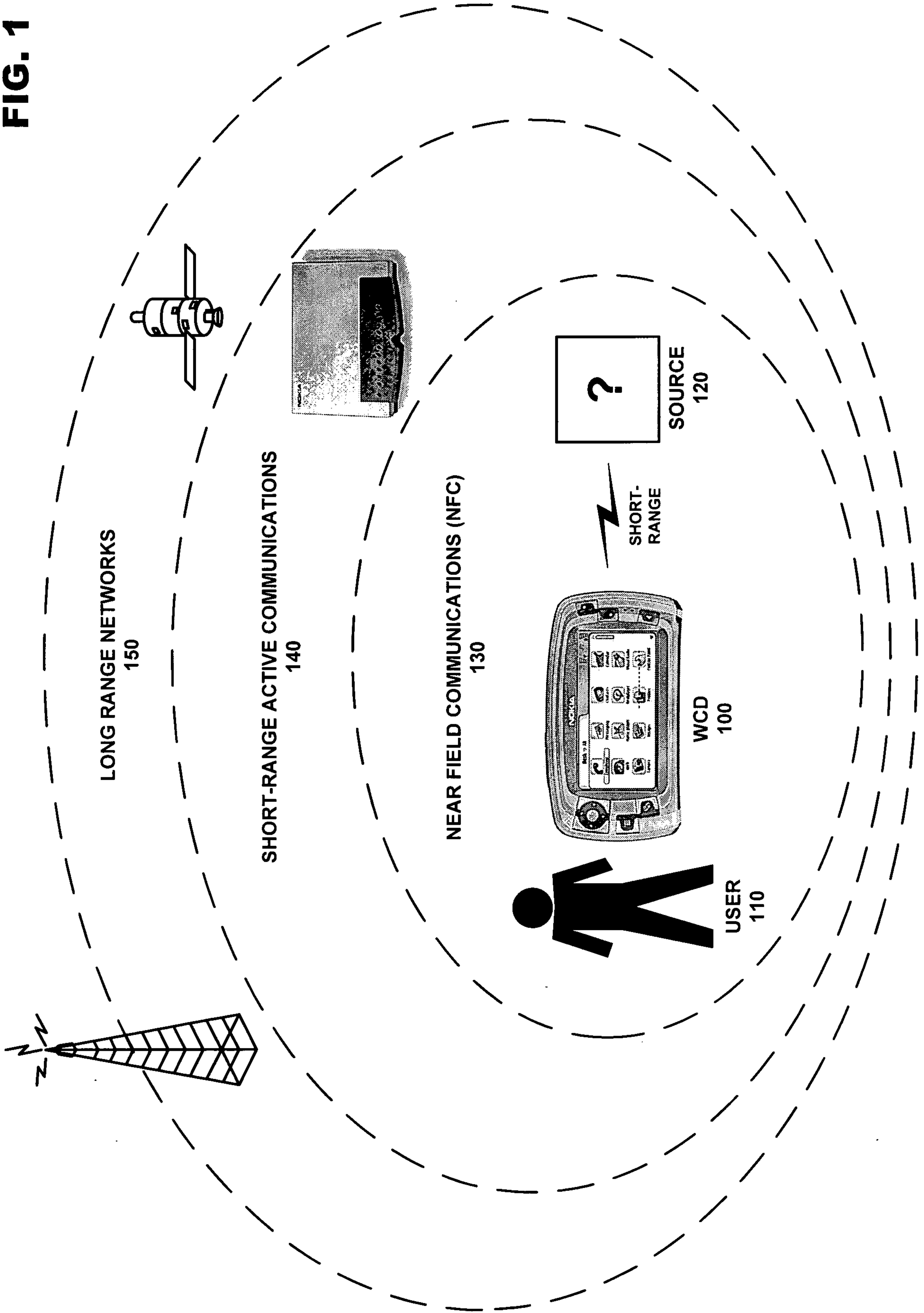

FIG. 2

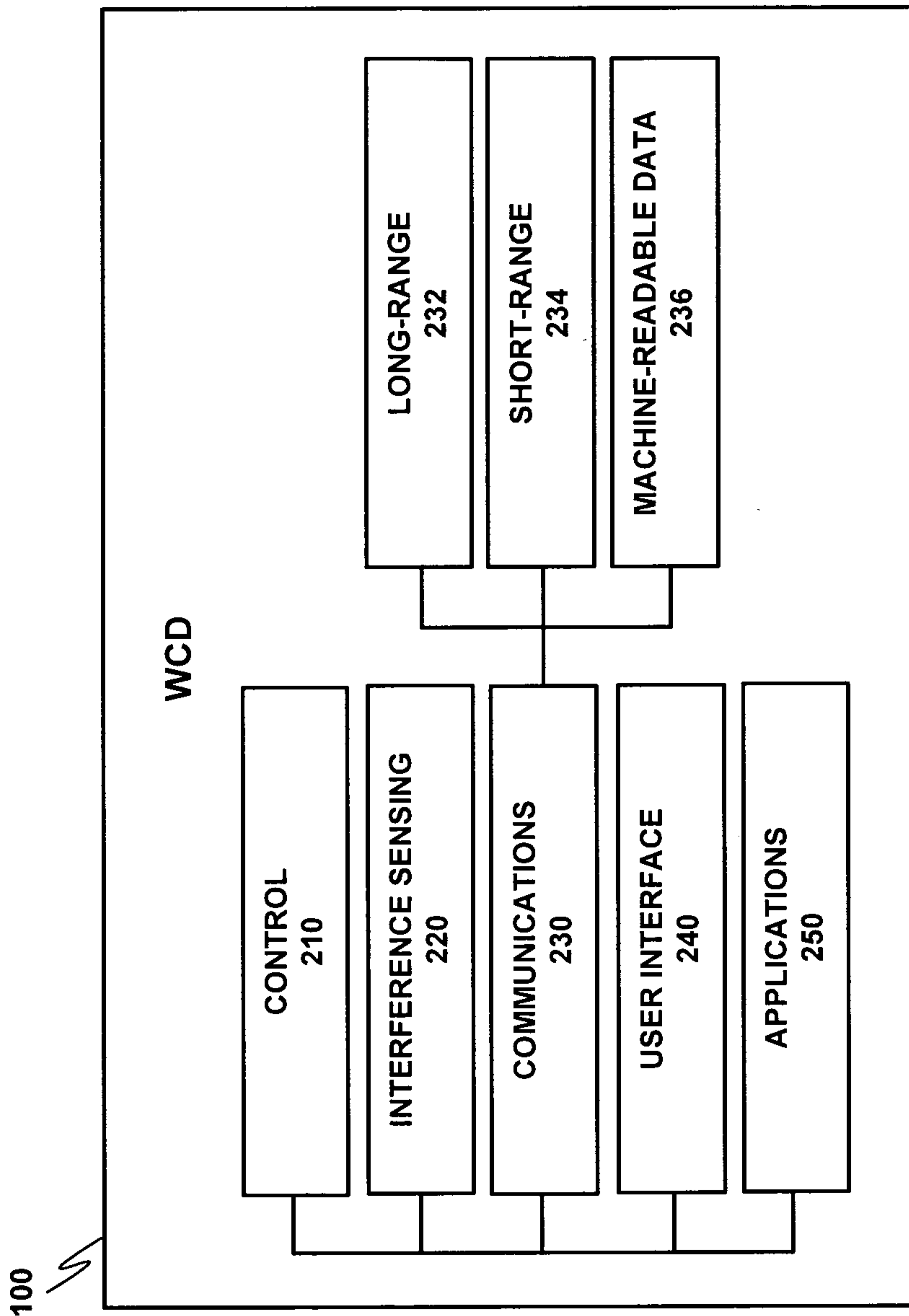

FIG. 3

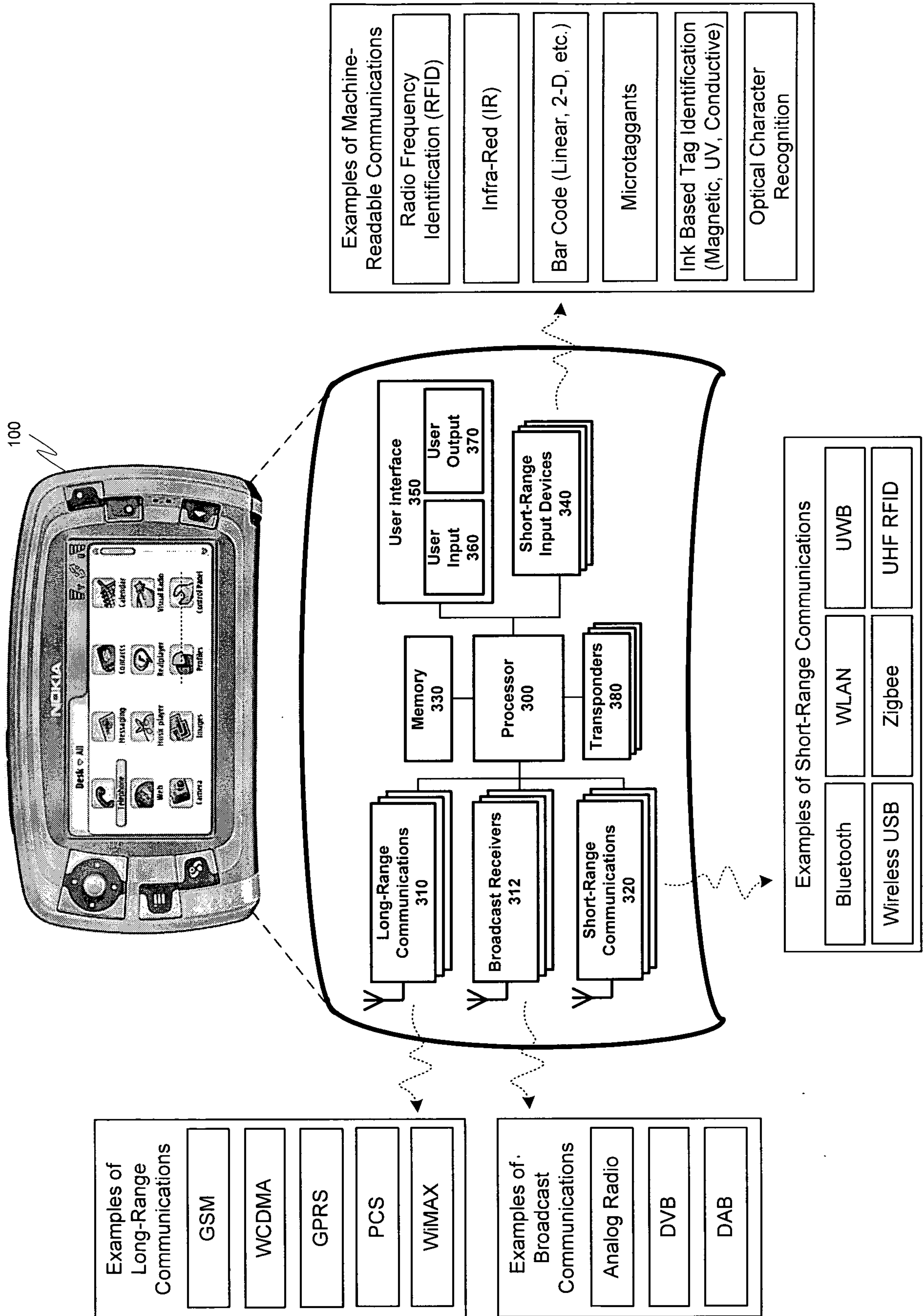

FIG. 4

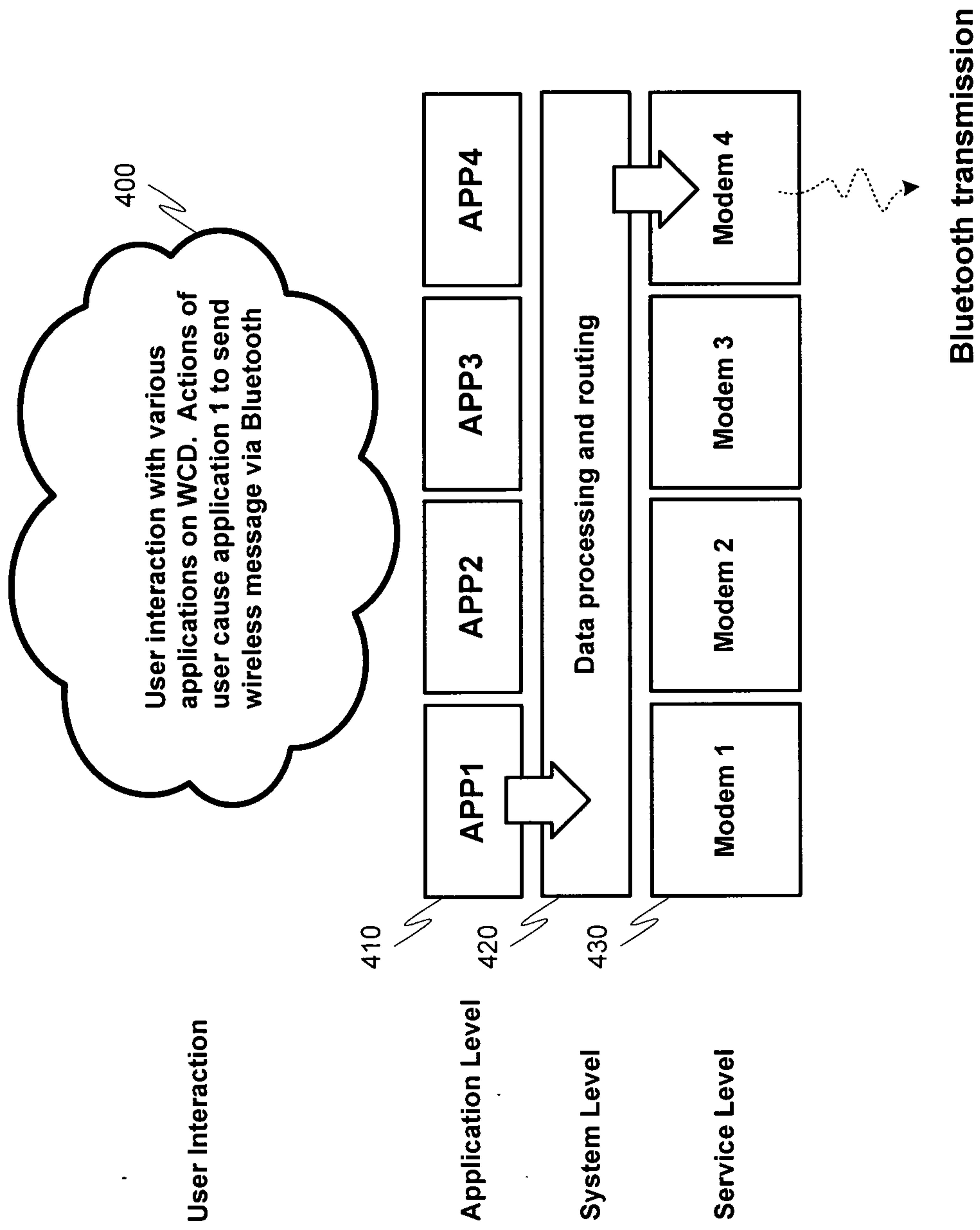

FIG. 5

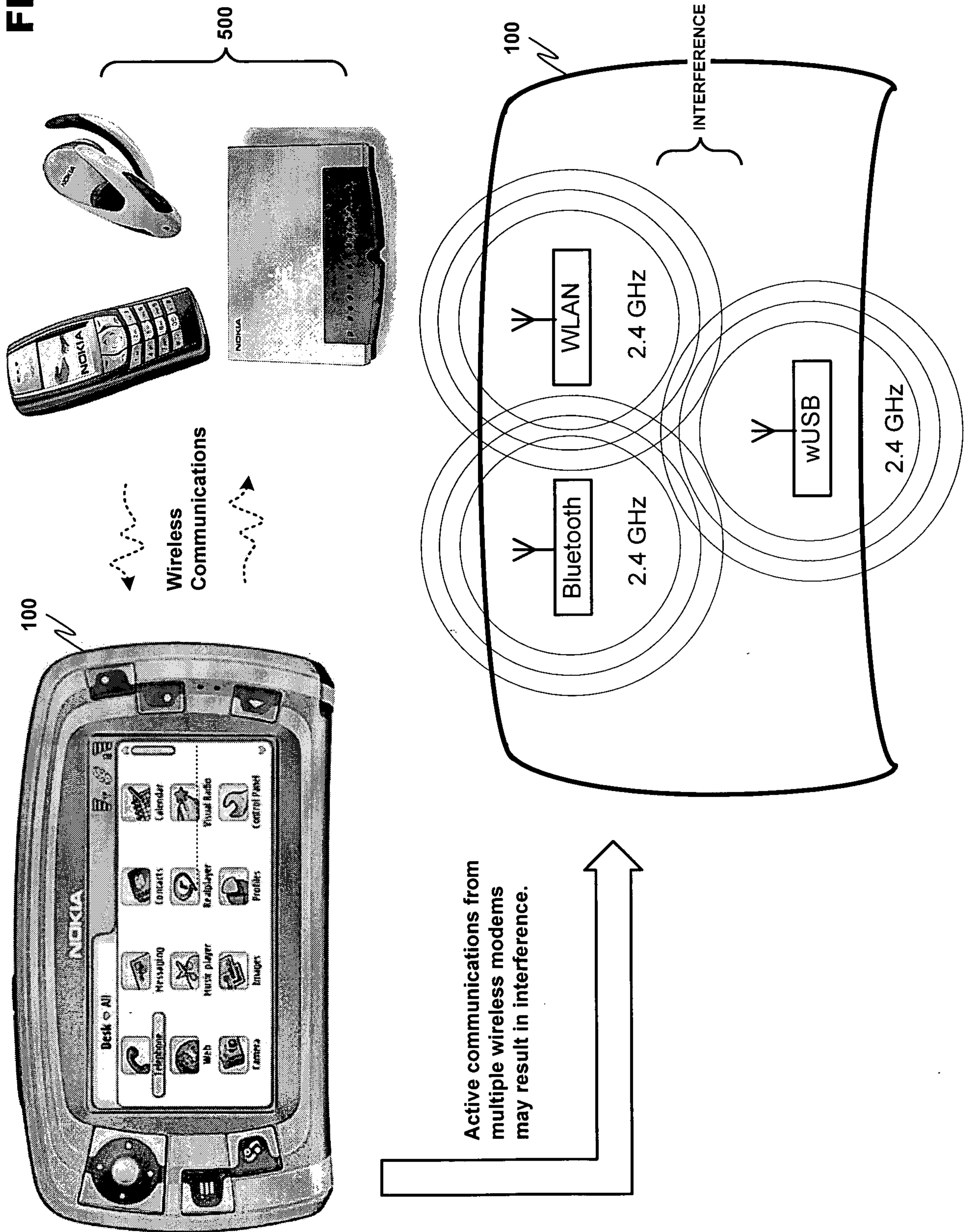

FIG. 6A

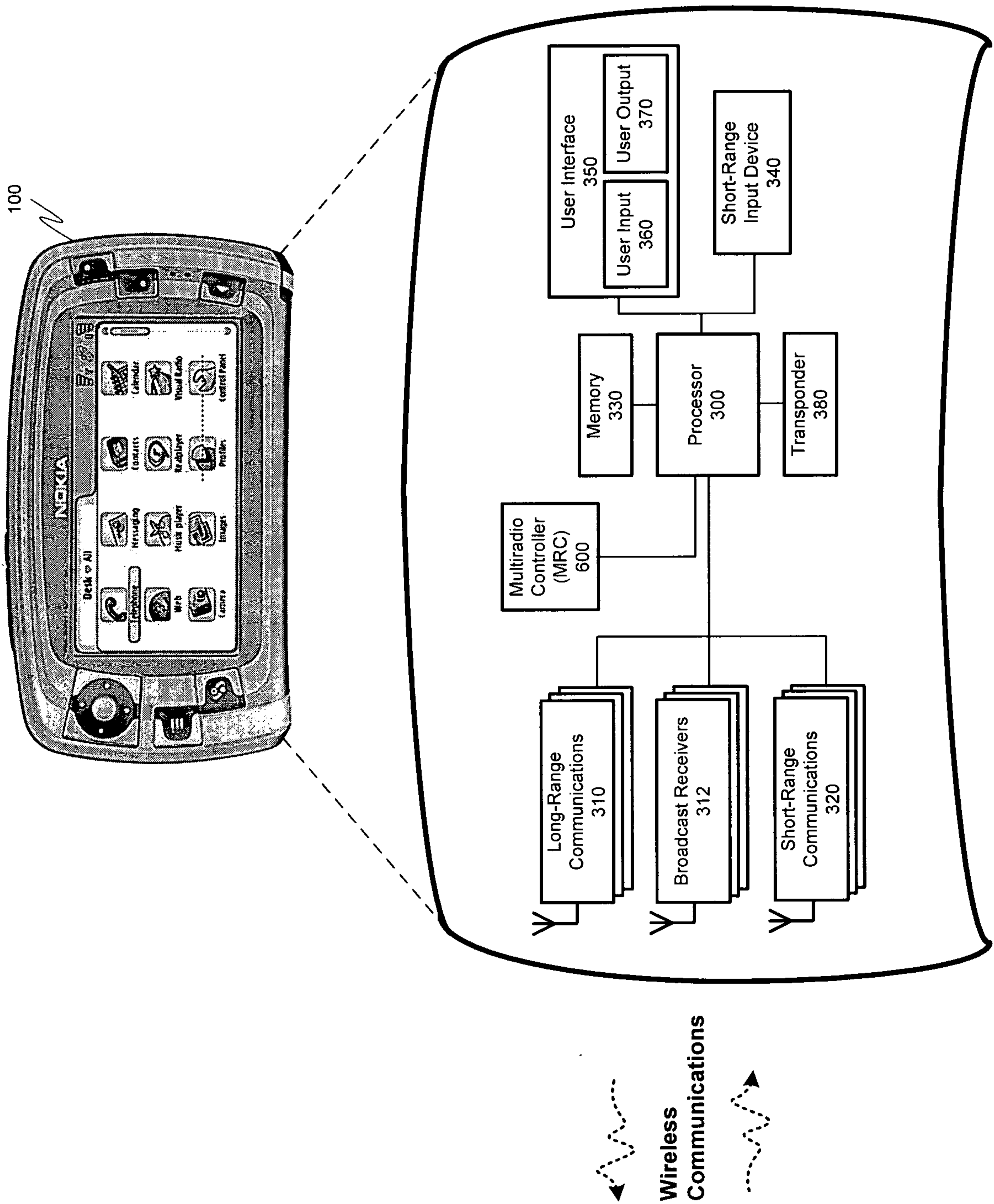

FIG. 6B

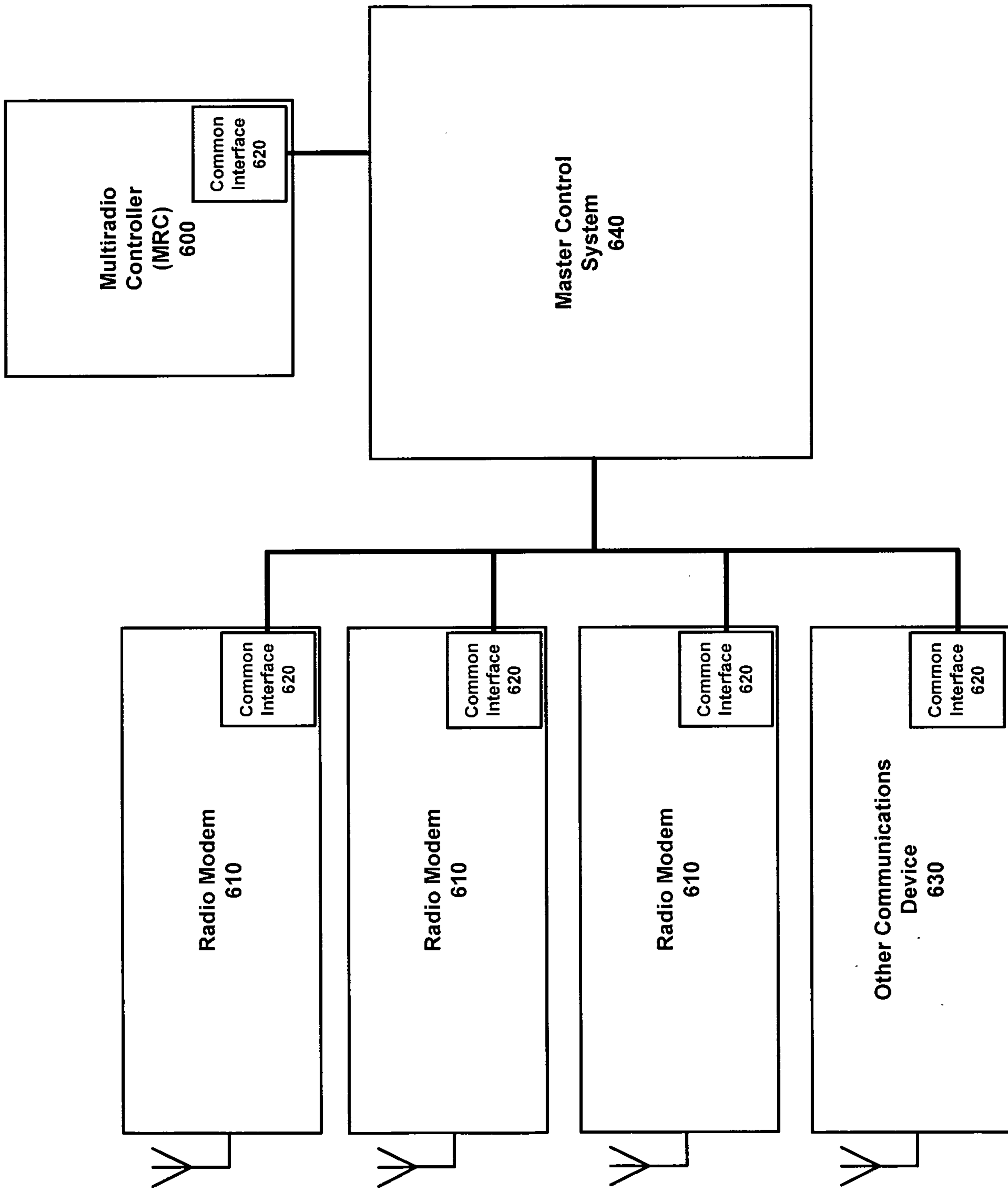

FIG. 6C

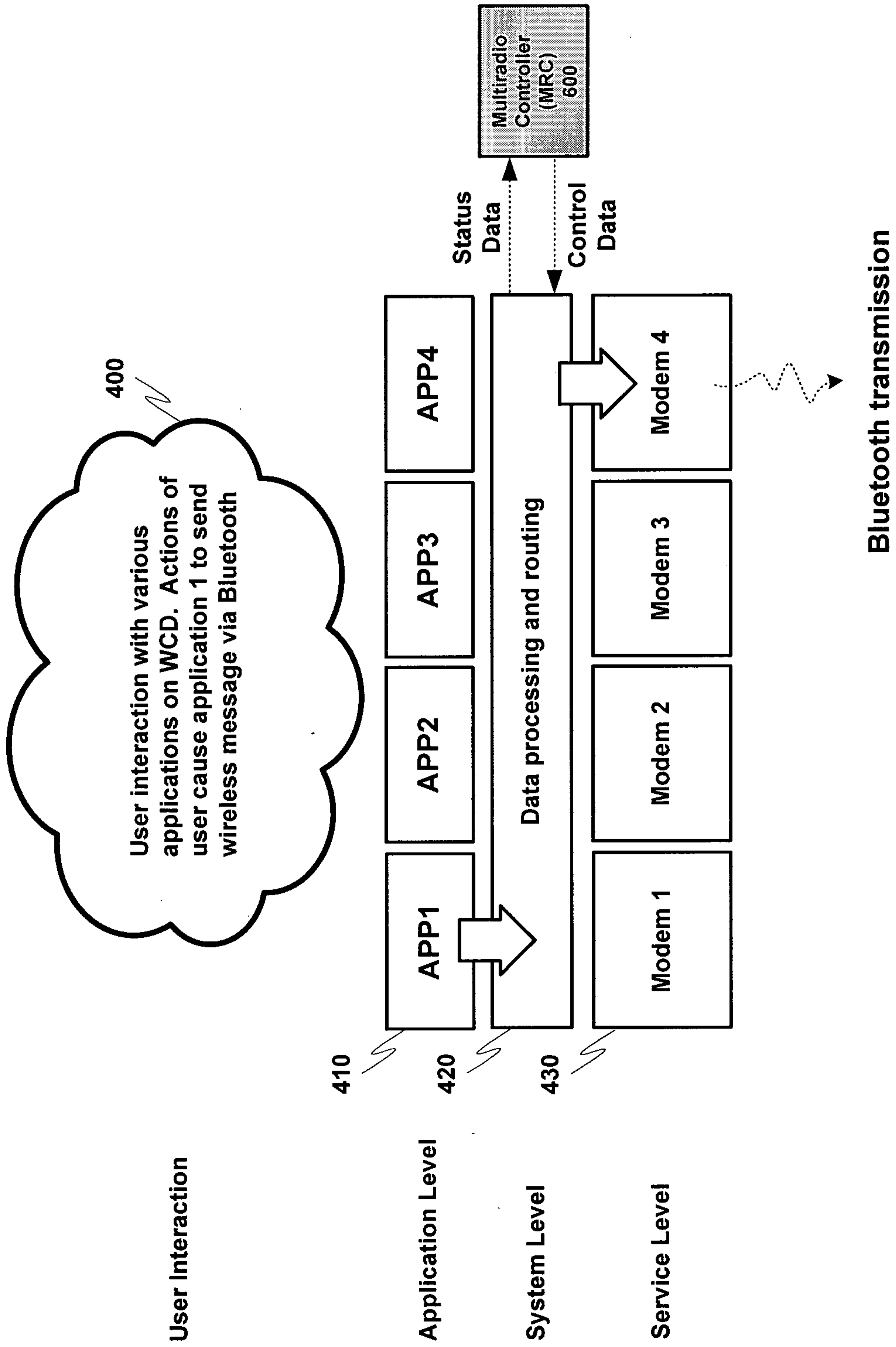

FIG. 7A

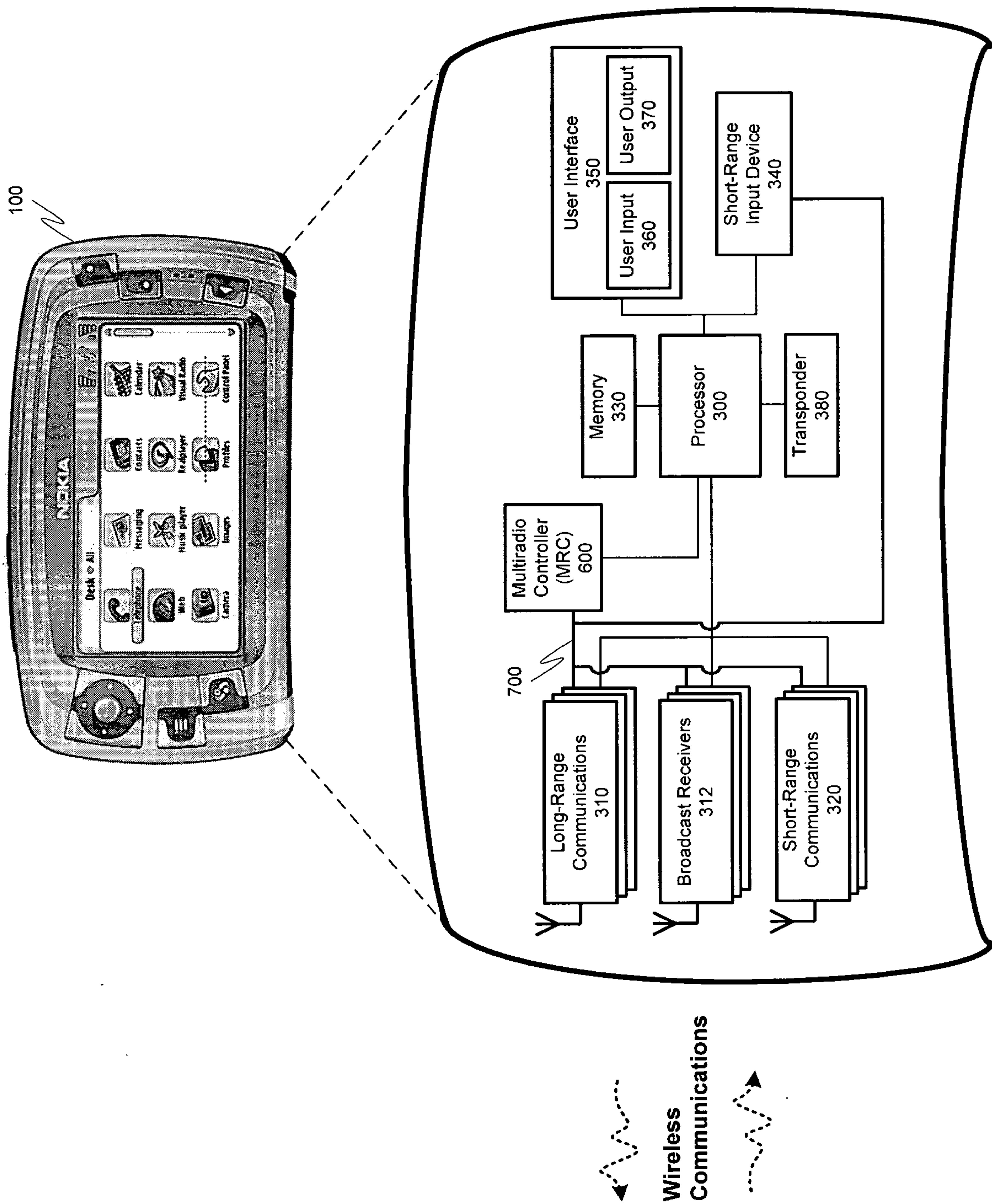

FIG. 7B

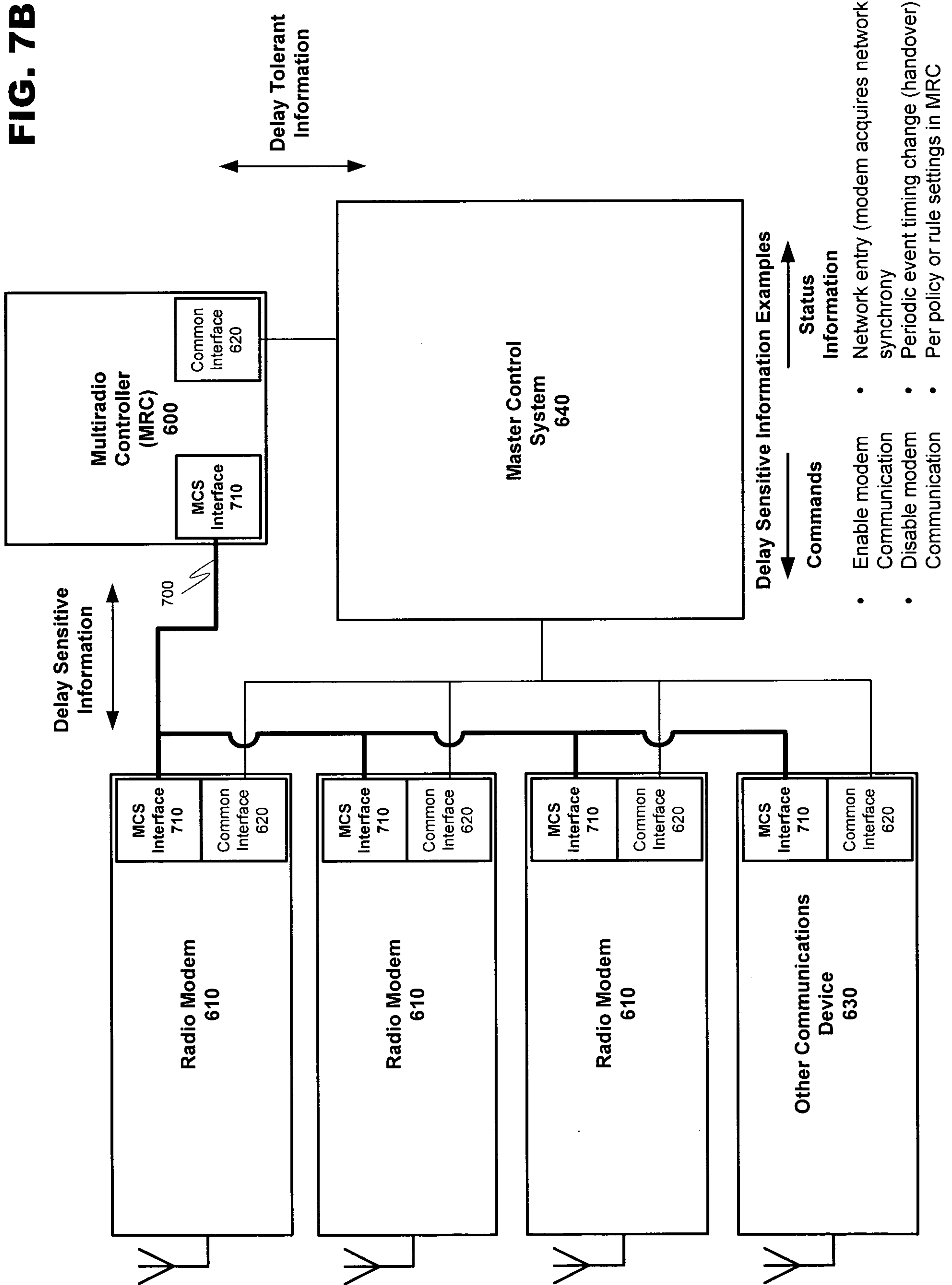

FIG. 7C

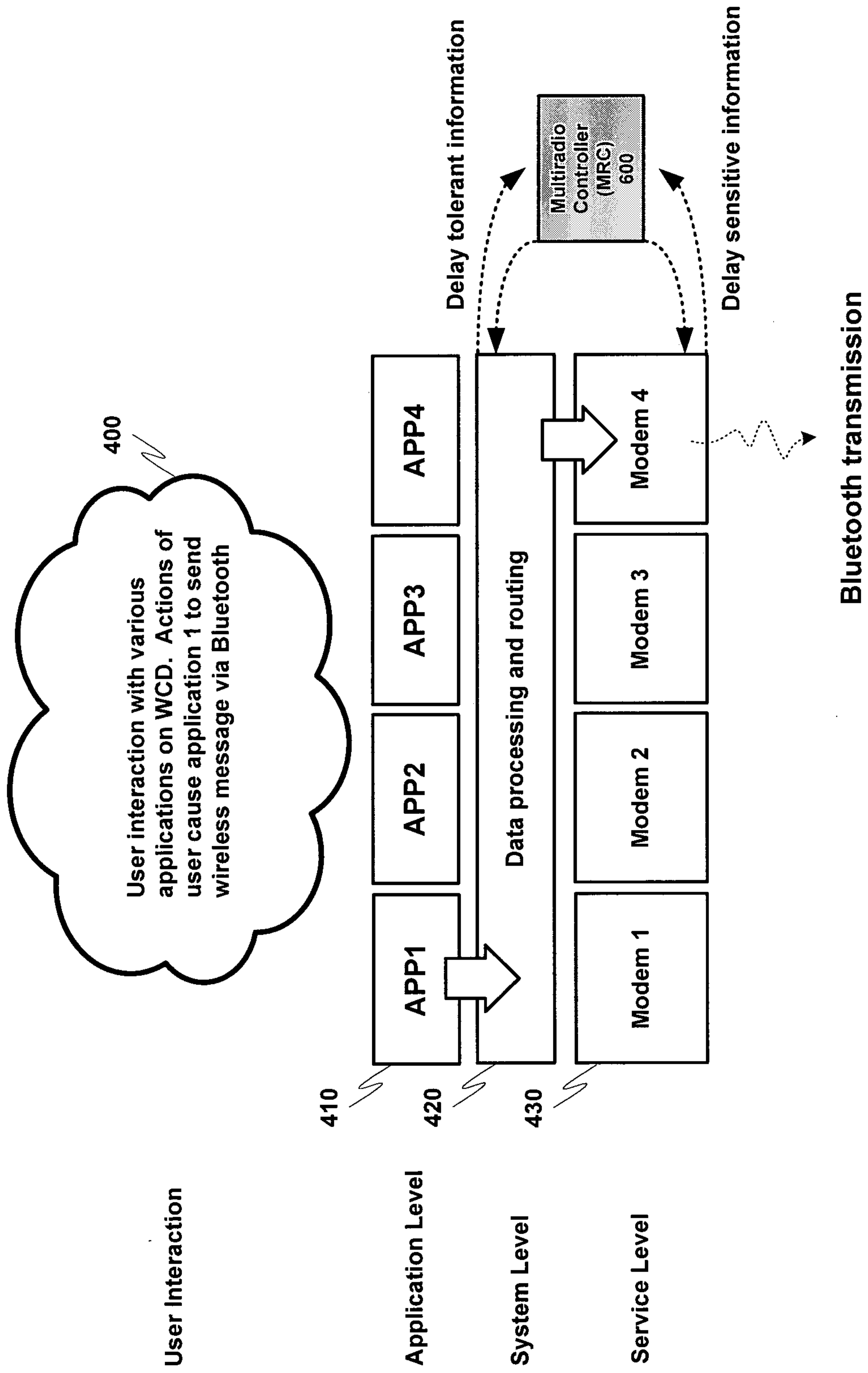

FIG. 8

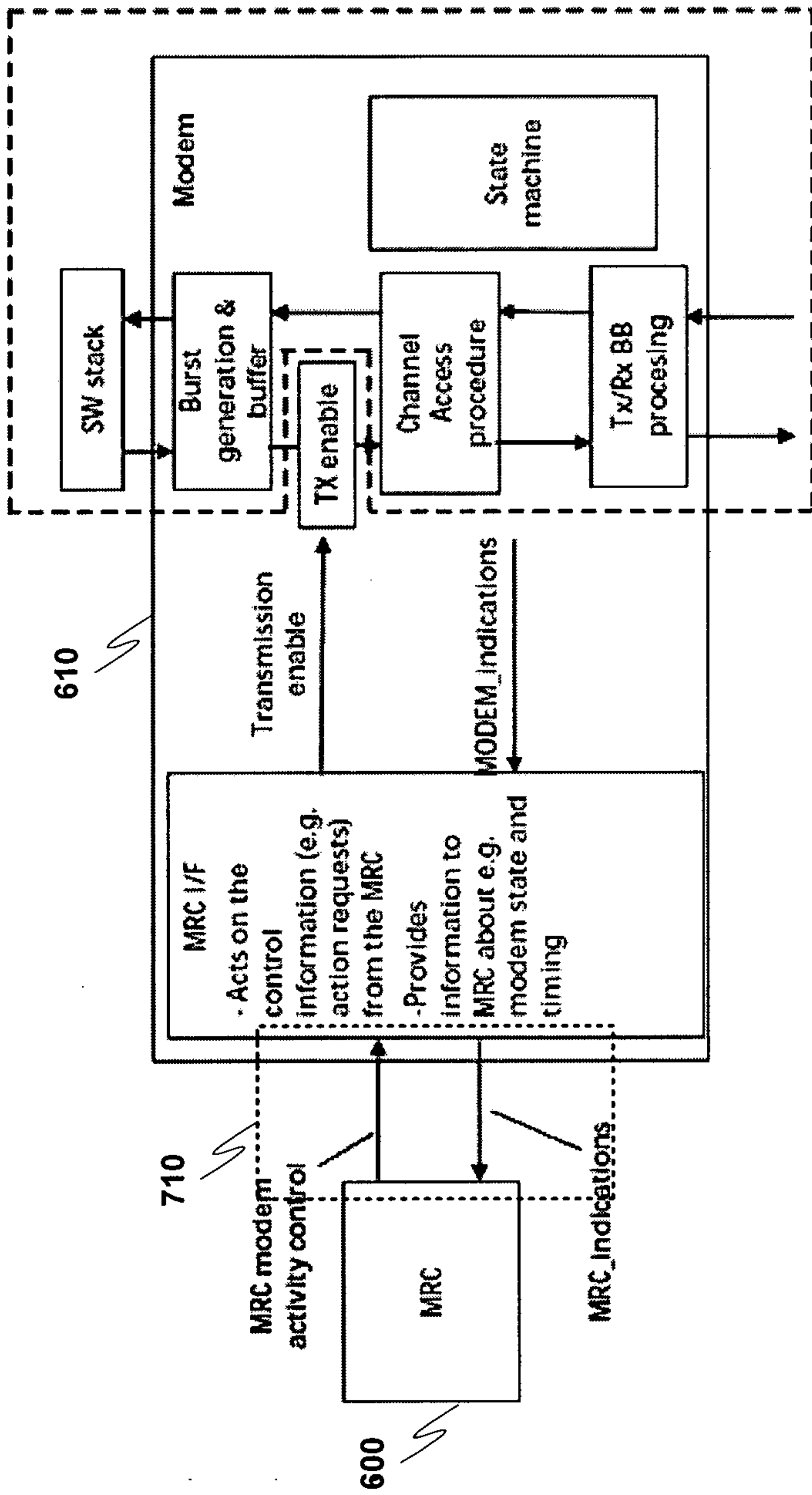

FIG. 9

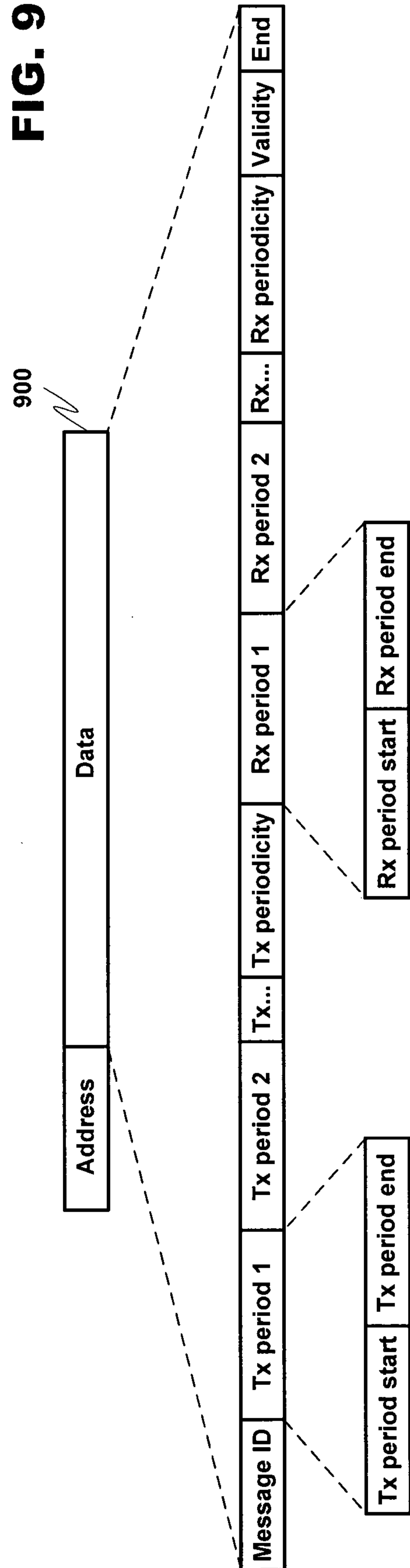

FIG. 10

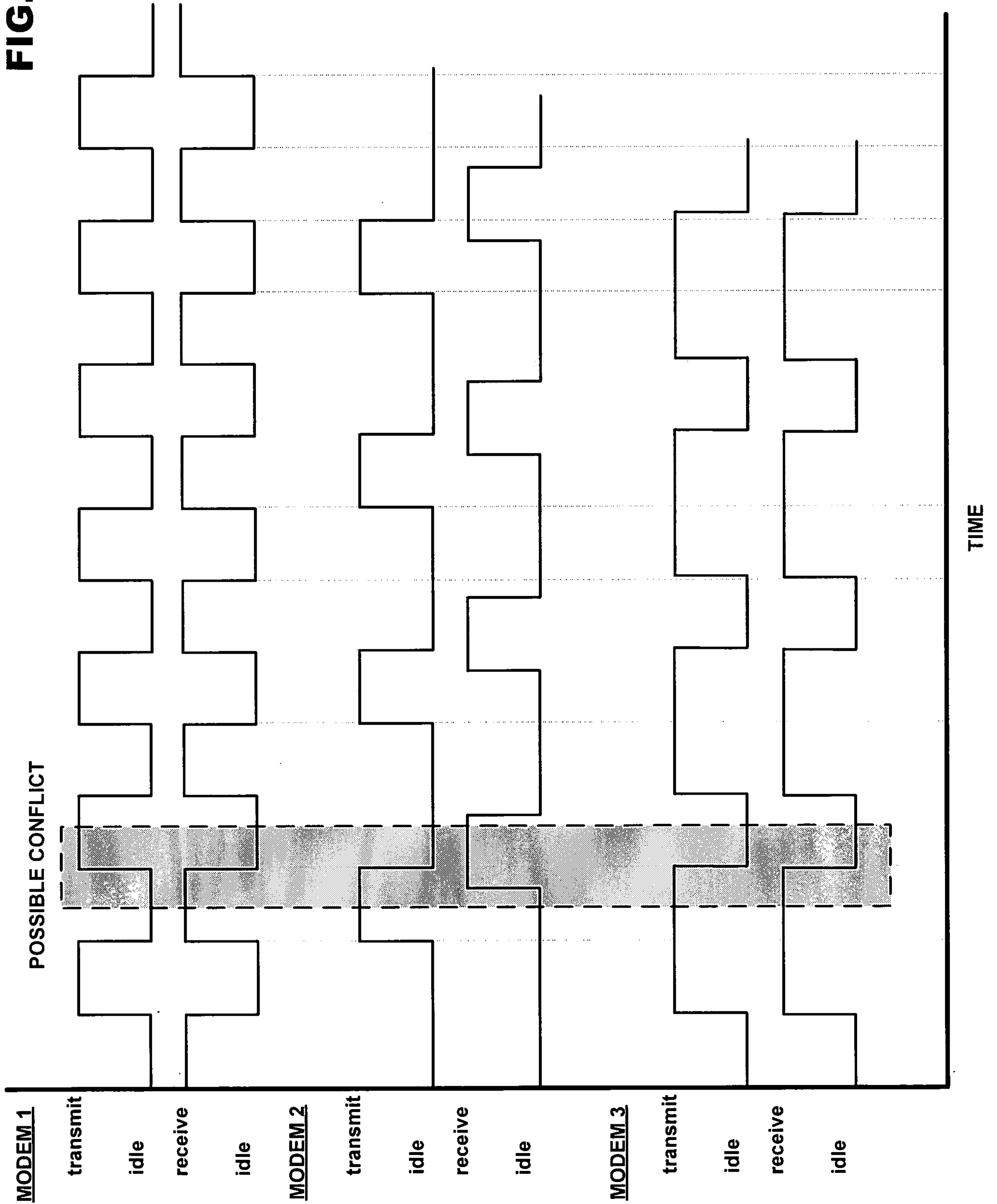

FIG. 11

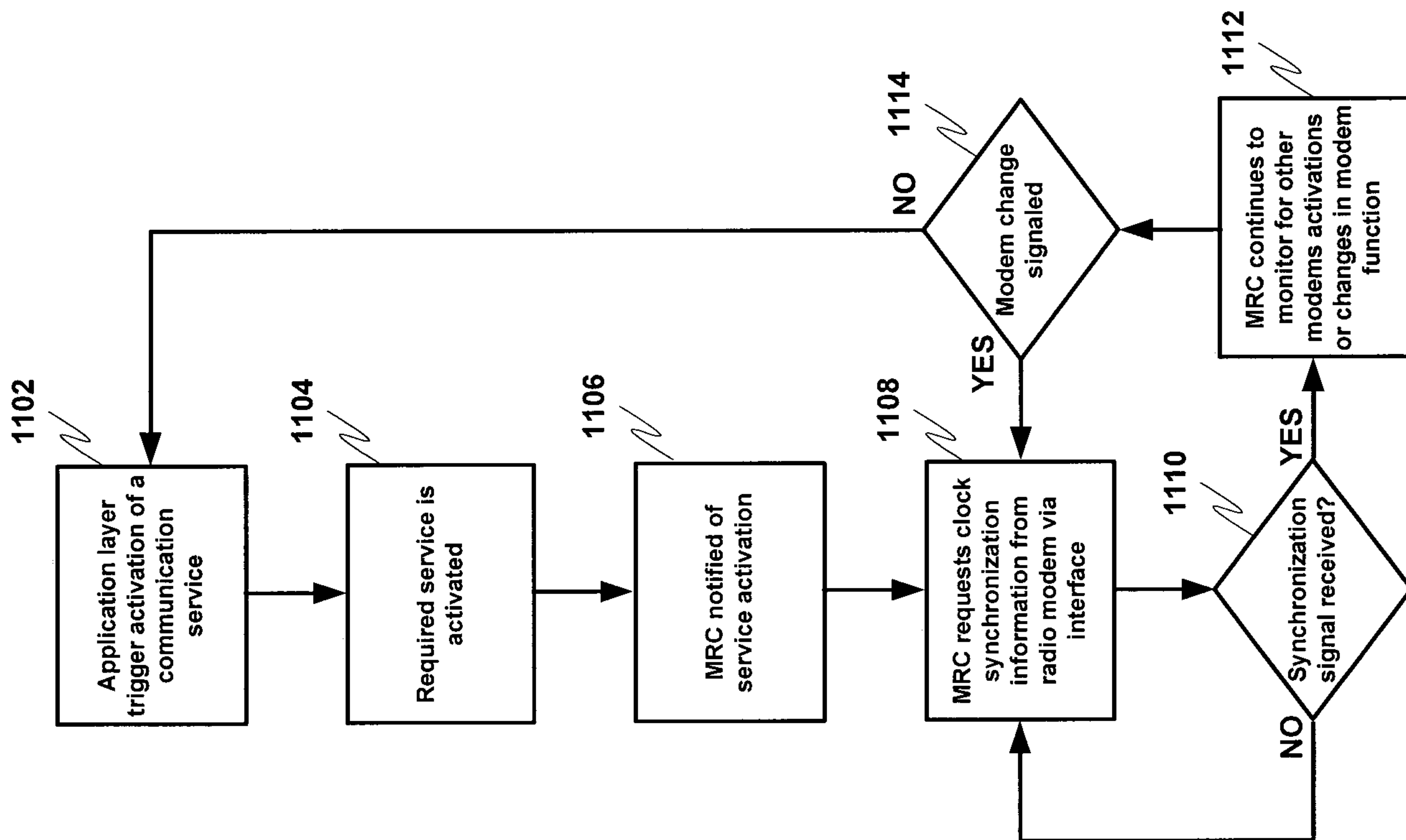

FIG. 12

